

ASSEMBLY INSTRUCTIONS



VANITY

PAGE 1 OF 21

ASSEMBLY INSTRUCTIONS

ASSEMBLY TIPS:

1. Remove hardware from box and sort by size.
2. Please check to see that all hardware and parts are present prior to start of assembly.
3. Please follow attached instructions in the same sequence as numbered to assure fast & easy assembly.



WARNING!

1. Don't attempt to repair or modify parts that are broken or defective. Please contact the store immediately.
2. This product is for home use only and not intended for commercial establishments.

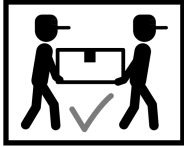

ASSEMBLY TIME 75 MINUTES

PARTS IDENTIFICATION

B2: VANITY BASE & GLASS

A

TOP PANEL

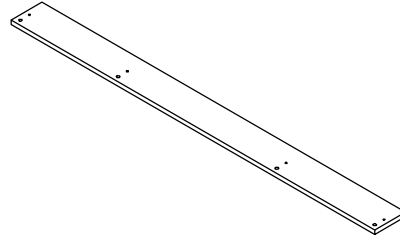

1PC

B

LEFT PANEL

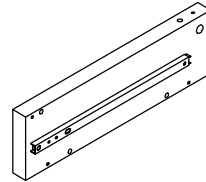

1PC

C

LEFT MIDDLE PANEL

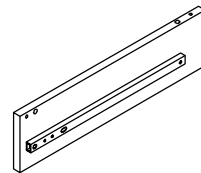

1PC

D

RIGHT MIDDLE PANEL

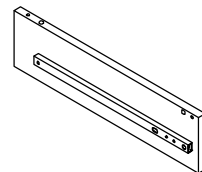

1PC

ASSEMBLY INSTRUCTIONS

PARTS IDENTIFICATION

E RIGHT PANEL

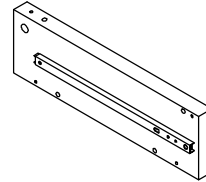

1PC

F BOTTOM PANEL

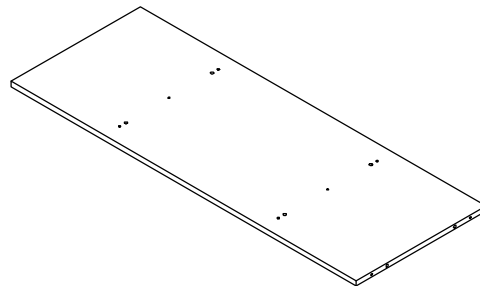

1PC

G BACK PANEL

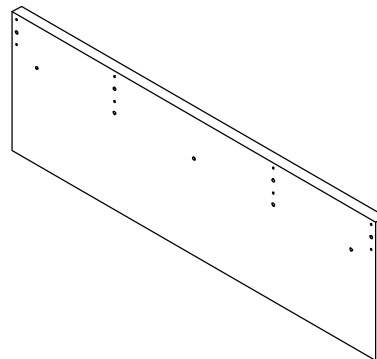

1PC

H LARGE DRAWER FRONT PANEL

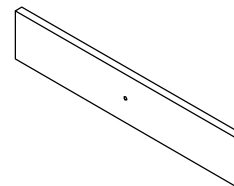

1PC

I DRAWER LEFT PANEL

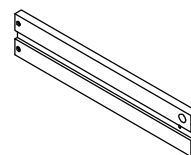

3PCS

ASSEMBLY INSTRUCTIONS

PARTS IDENTIFICATION

J DRAWER RIGHT PANEL

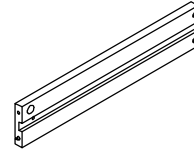

3PCS

K LARGE DRAWER BACK PANEL

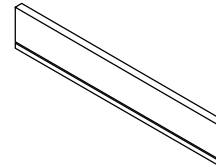

1PC

L LARGE DRAWER BOTTOM PANEL

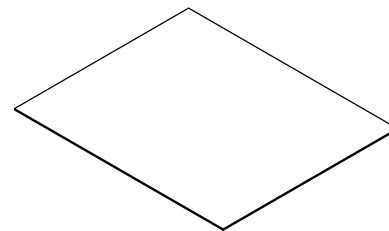

1PC

M SMALL DRAWER FRONT PANEL

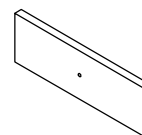

2PCS

N SMALL DRAWER BACK PANEL

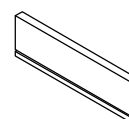

2PCS

ASSEMBLY INSTRUCTIONS

PARTS IDENTIFICATION

O SMALL DRAWER BOTTOM PANEL

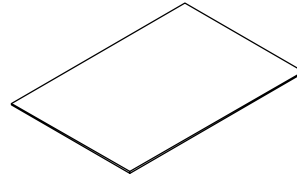

2PCS

P SHORT FRONT SUPPORT PANEL

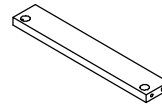

2PCS

Q LONG FRONT SUPPORT PANEL

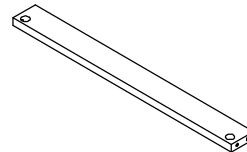

1PC

R TOP GLASS

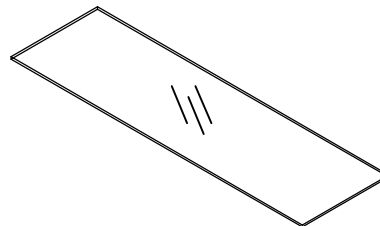

1PC

S SIDE GLASS



2PCS

ASSEMBLY INSTRUCTIONS

PARTS IDENTIFICATION

T SUPPORT CROSSBAR

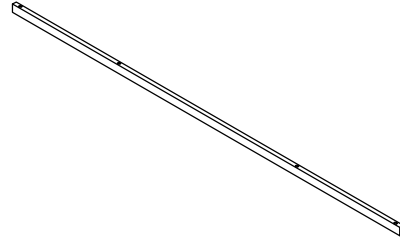

1PC

U PLASTIC BAR

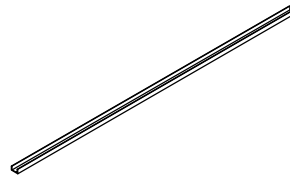

2PCS

V HANDLE



3PCS

B1: VANITY TOP

A1 CROSSBAR

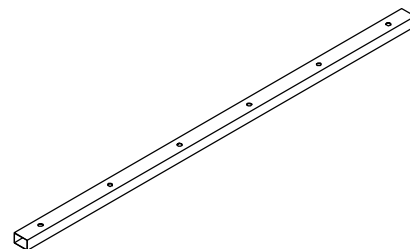

2PCS

A2 MAKE-UP MIRROR

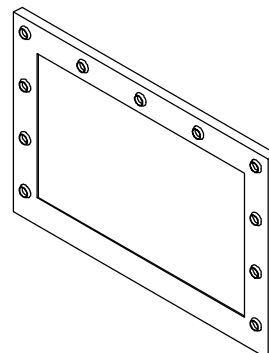

1PC

ASSEMBLY INSTRUCTIONS

PARTS IDENTIFICATION

B3: 11PCS LIGHT BULB

A3

LIGHT BULB



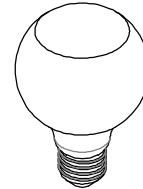

















TYPE G / E26 CLEAR LIGHT BULB / 4 WATT.



11PCS

ASSEMBLY INSTRUCTIONS

HARDWARE IDENTIFICATION

1	CAM BOLT (33MM)		20PCS	12	CAP (13 x 26mm)		4PCS
2	ALLEN WRENCH (4mm)		1PC	13	SUCTION CUP		8PCS
3	LARGE CAM-LOCK (Ø15MM)		14PCS	14	LARGE BOLT (1/4" x 25mm SR)		12PCS
4	SMALL CAM-LOCK (Ø12mm)		6PCS	15	SMALL BOLT (1/4" x 25mm SR)		8PCS
5	LARGE WOOD DOWEL (8 x 30mm)		27PCS	16	WASHER (Ø16mm)		8PCS
6	SMALL WOOD DOWEL (6 x 25mm)		6PCS	17	PLASTIC WASHER (Ø15mm)		8PCS
7	SHORT WOOD SCREW (8 x 25mm)		12PCS	18	COVER		8PCS
8	MEDIUM WOOD SCREW (8 X 38mm)		4PCS	19	SHORT SCREW (4 x 28mm)		4PCS
9	LONG WOOD SCREW (8 x 45mm)		8PCS	20	GLUE		1PC
10	SMALL BOLT (5/32" x10mm)		6PCS				
11	HANDLE BOLT (5/32" x22mm)		3PCS				

Hardware pack is located in 935923B2

ASSEMBLY INSTRUCTIONS

STEP 1 Do not tighten until each step is completed or instructed.

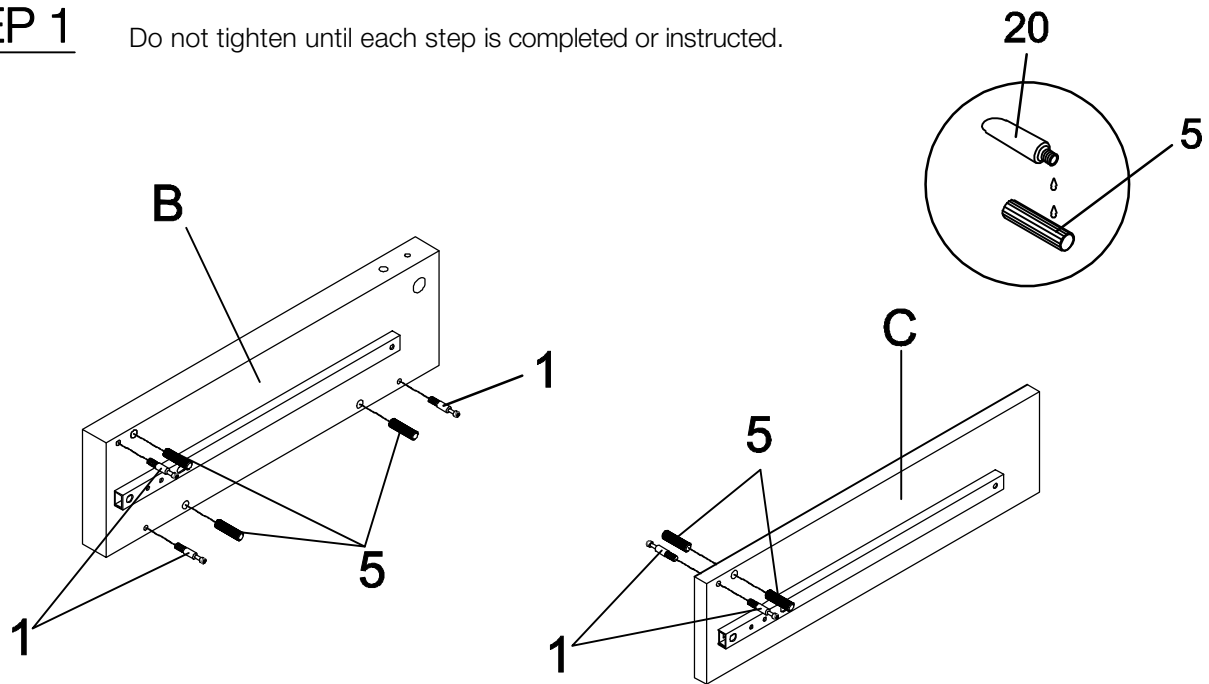

STEP 2

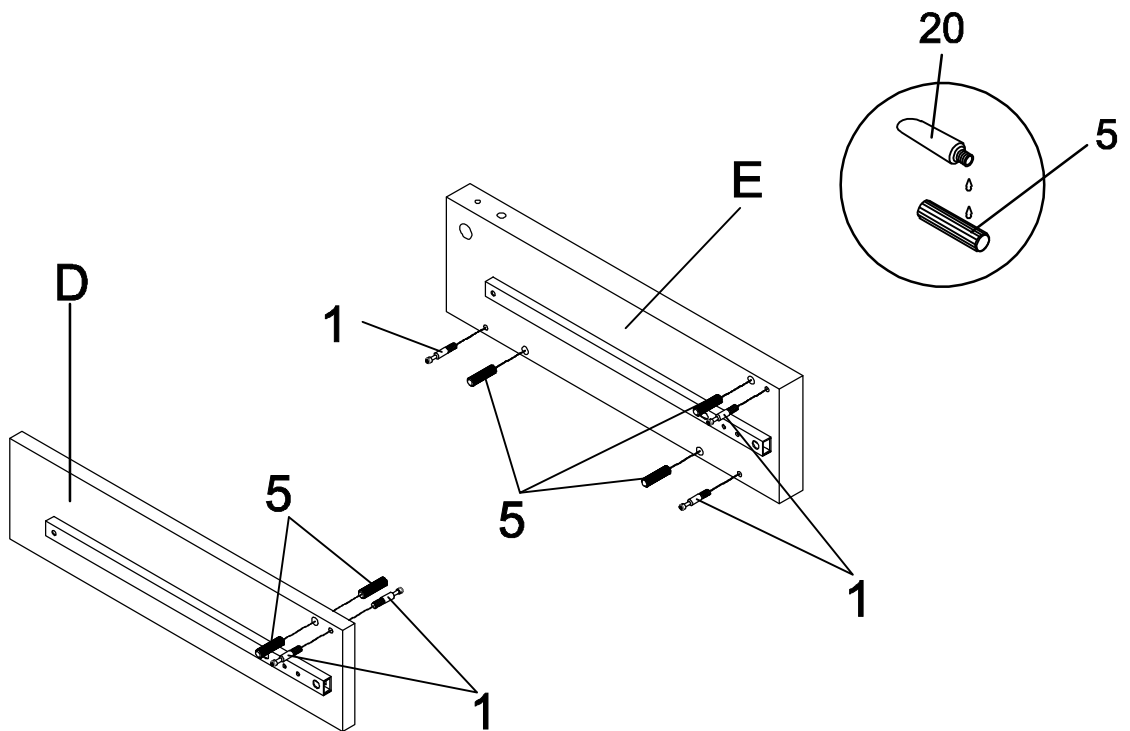

ASSEMBLY INSTRUCTIONS

STEP 3

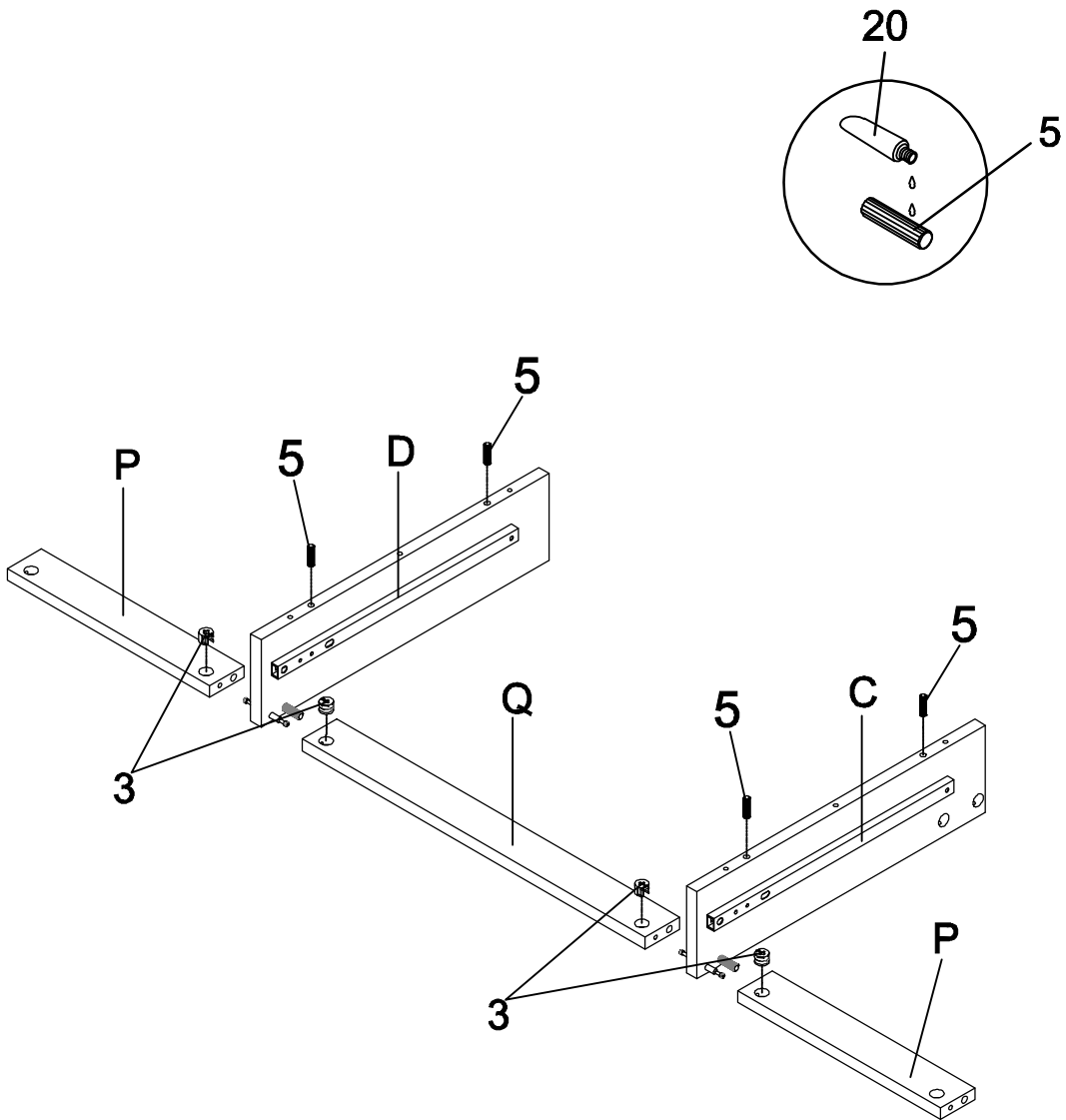

ASSEMBLY INSTRUCTIONS

STEP 4

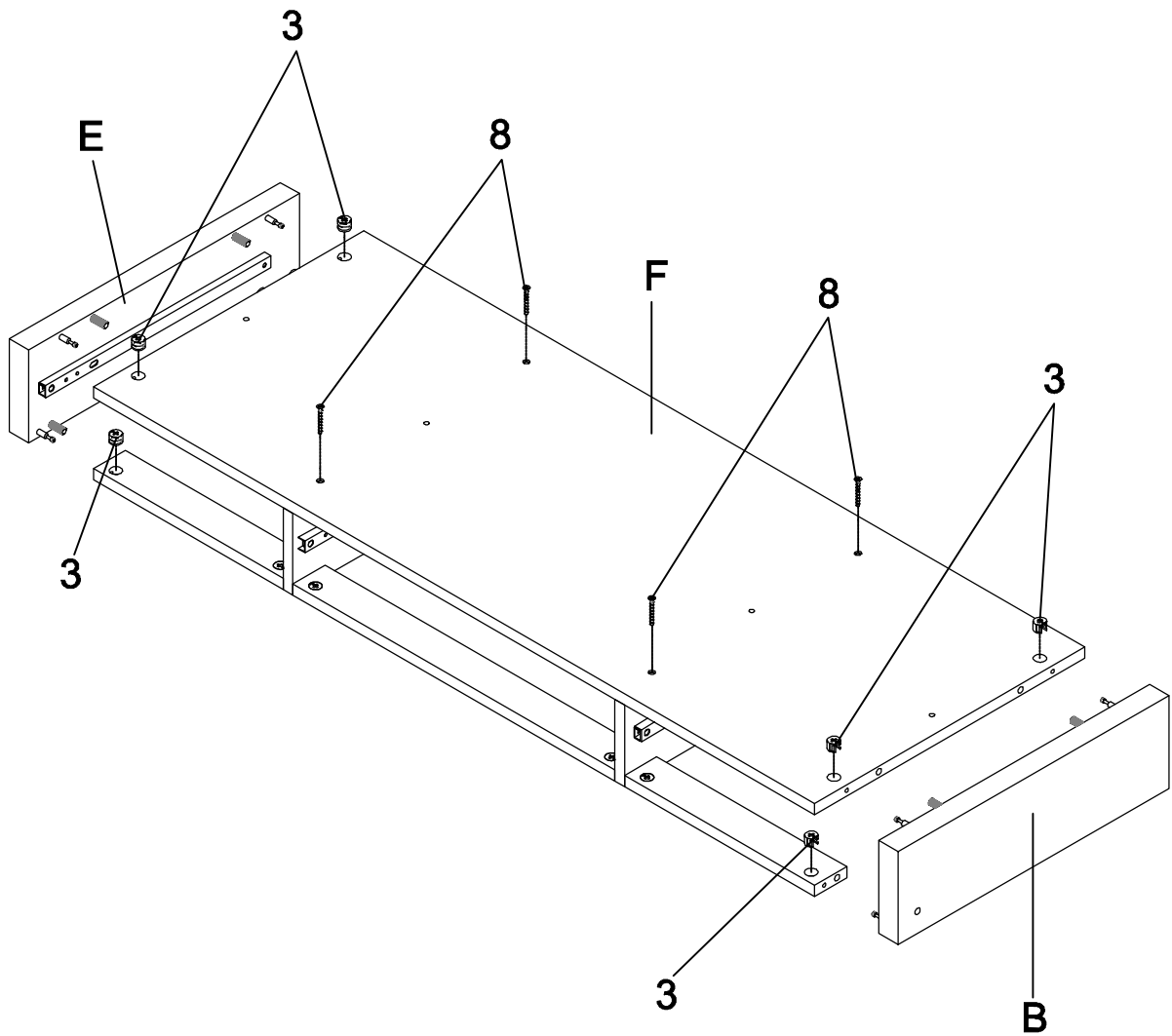

ASSEMBLY INSTRUCTIONS

STEP 5

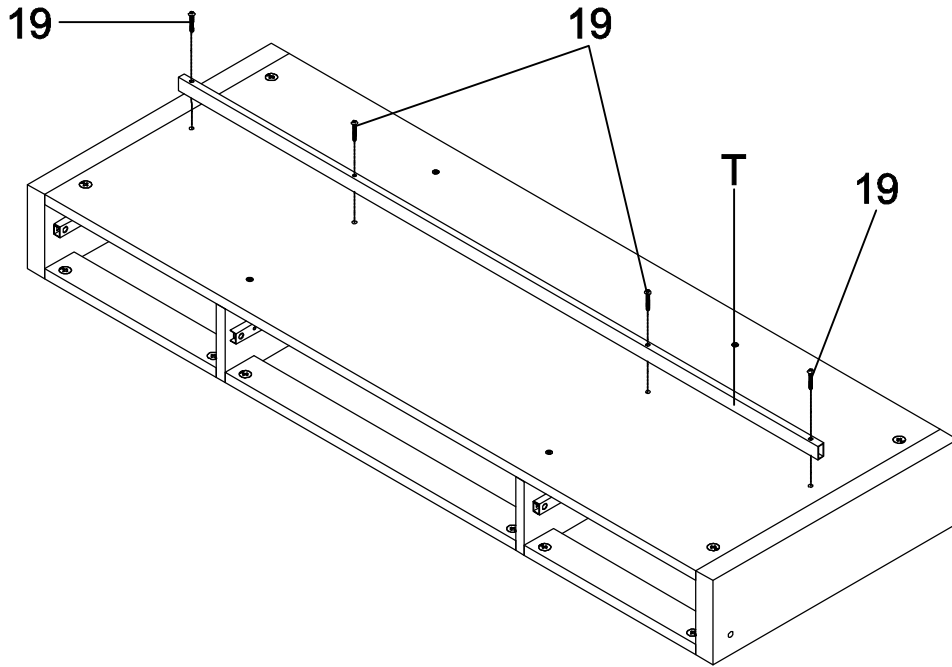

STEP 6

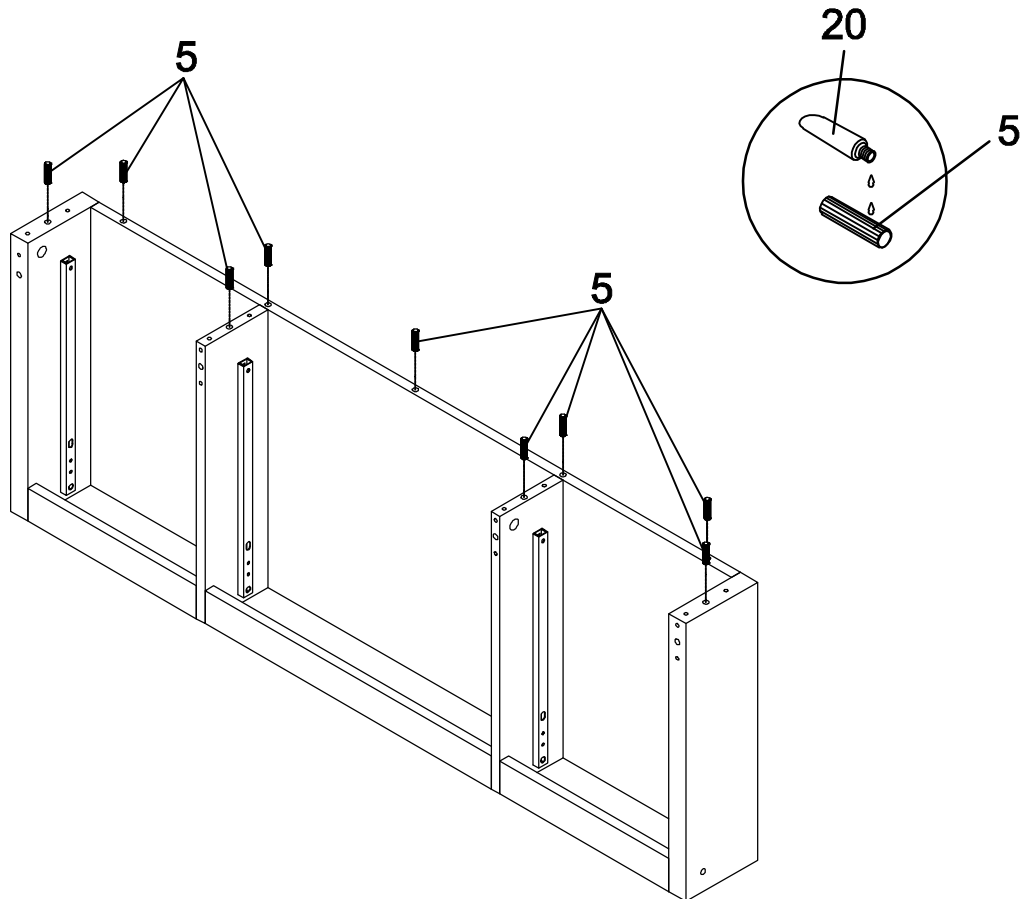

ASSEMBLY INSTRUCTIONS

STEP 7

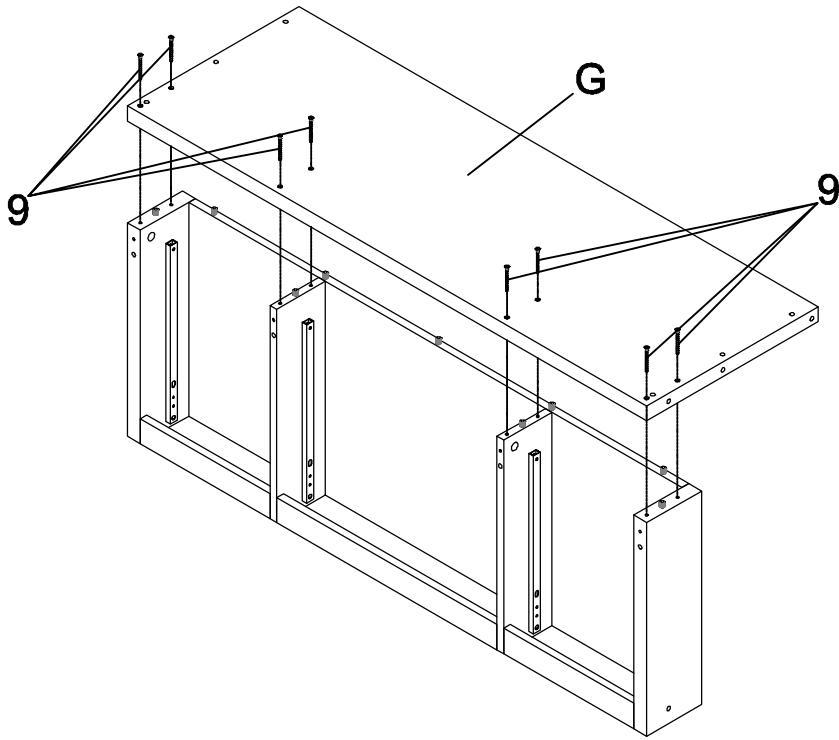

STEP 8

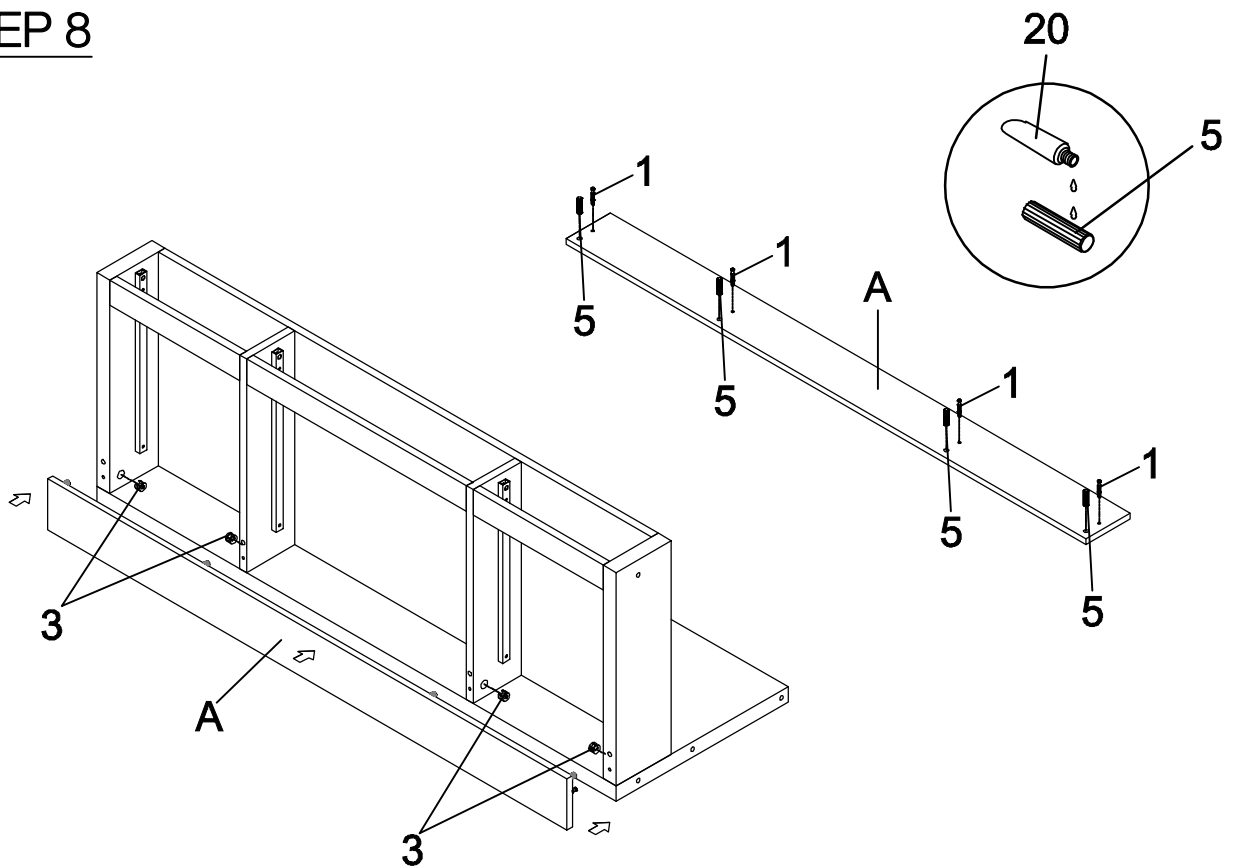

ASSEMBLY INSTRUCTIONS

STEP 9

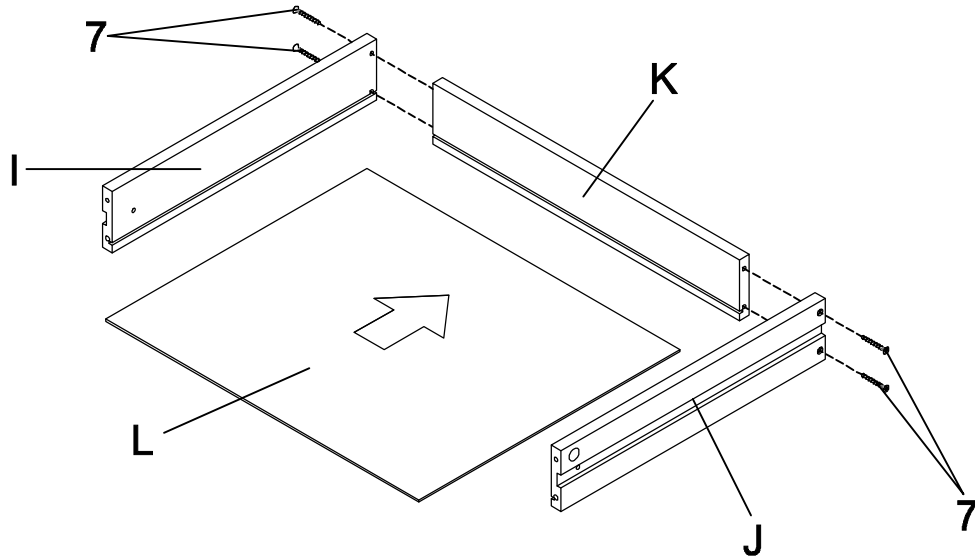

STEP 10

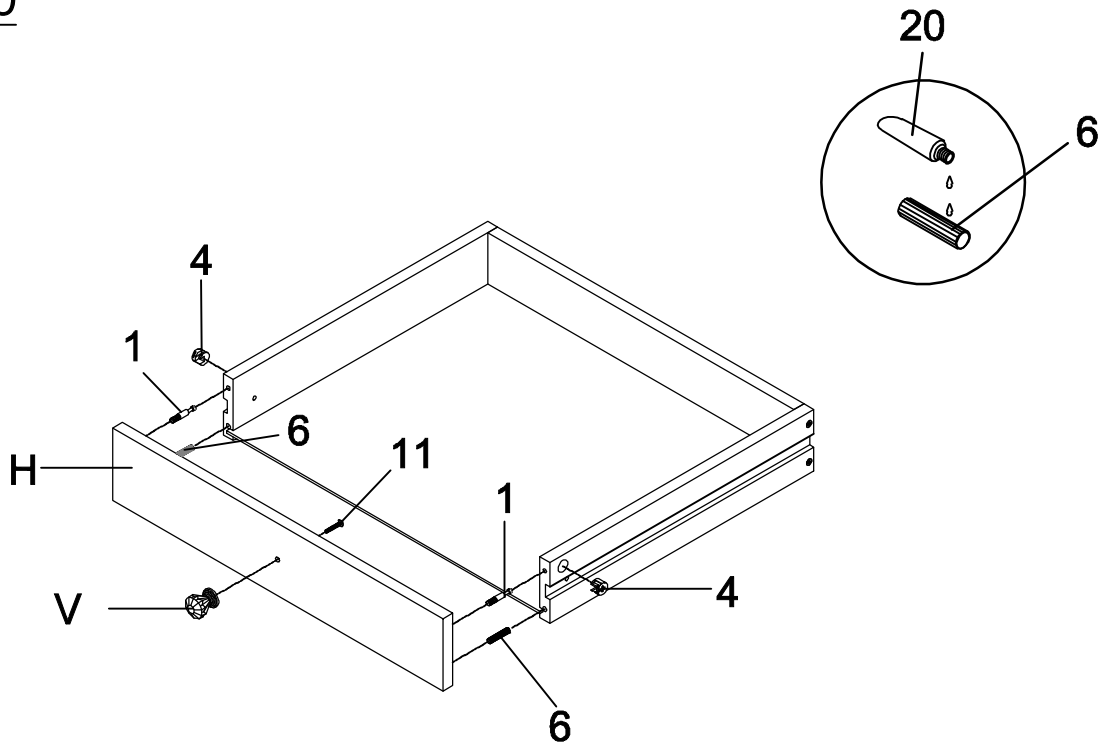

ASSEMBLY INSTRUCTIONS

STEP 11

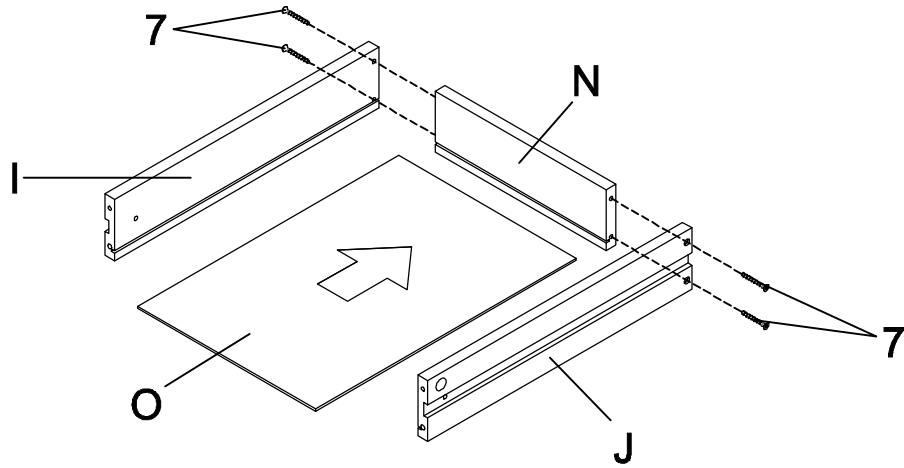

STEP 12

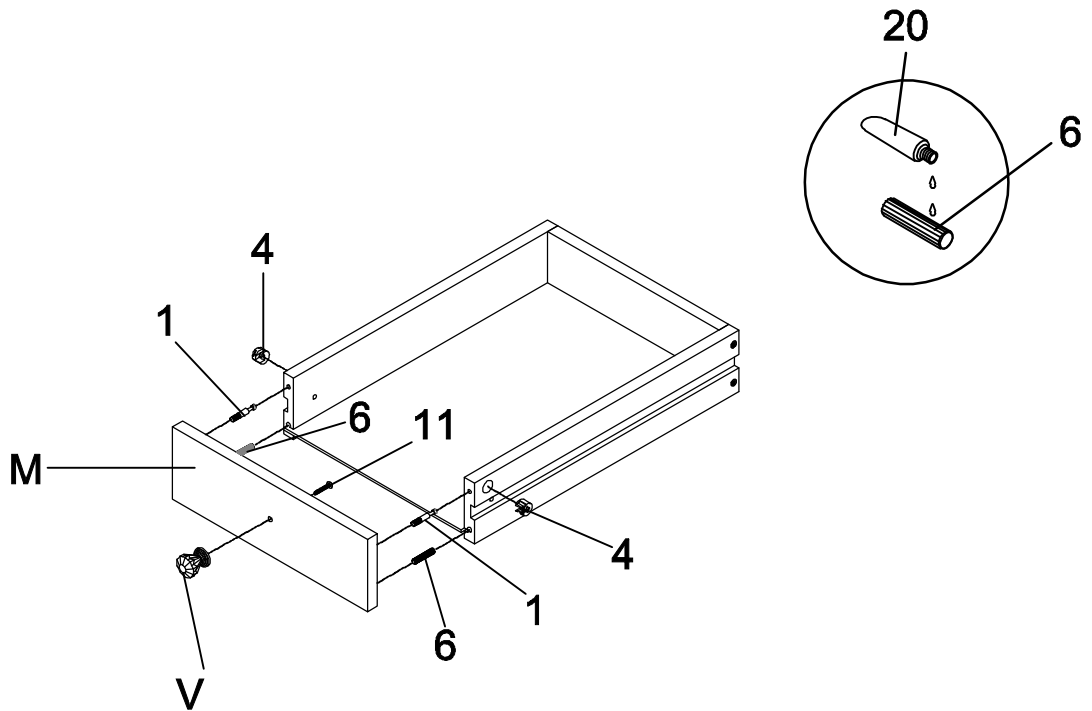

ASSEMBLY INSTRUCTIONS

STEP 13

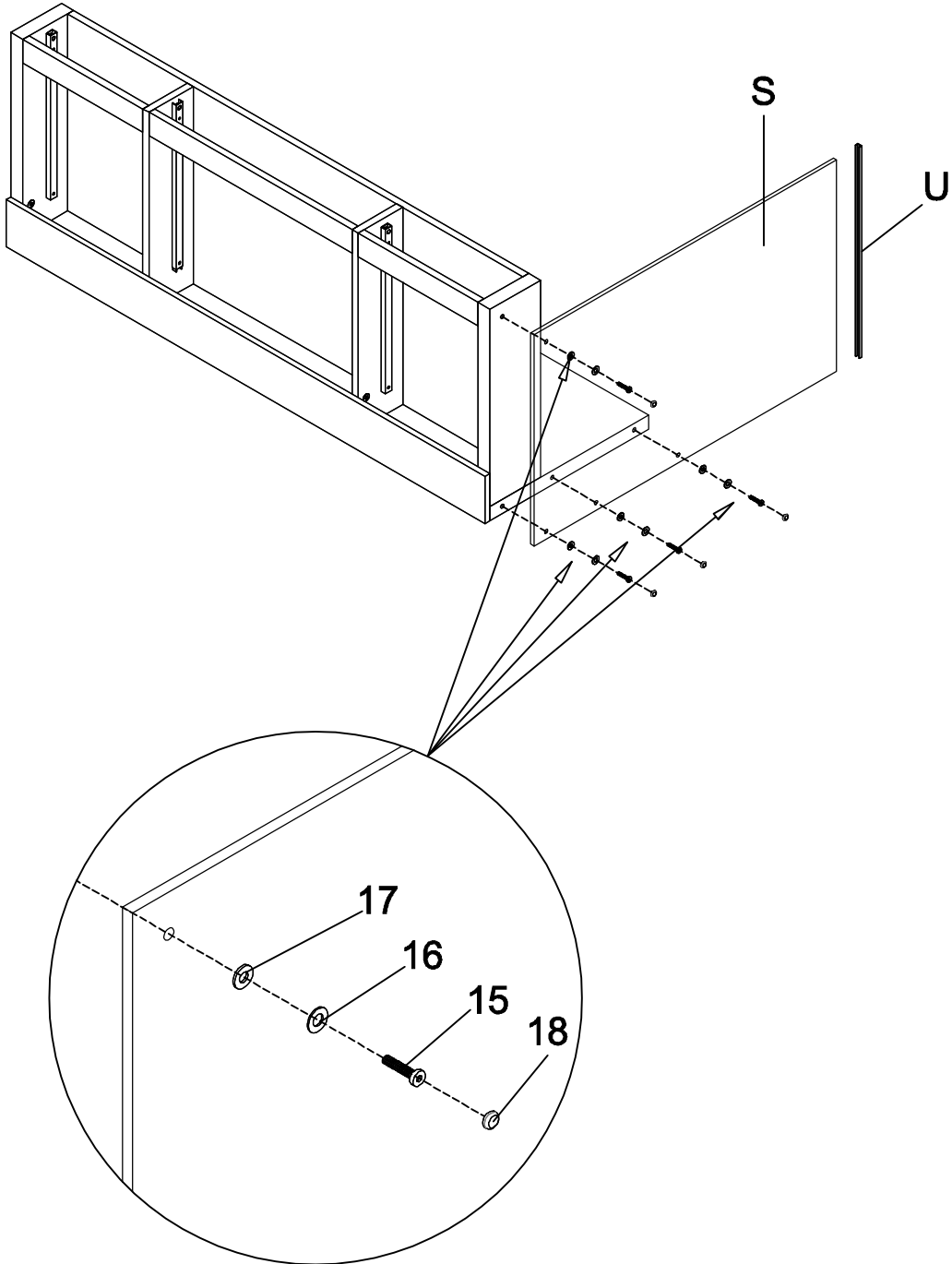

ASSEMBLY INSTRUCTIONS

STEP 14

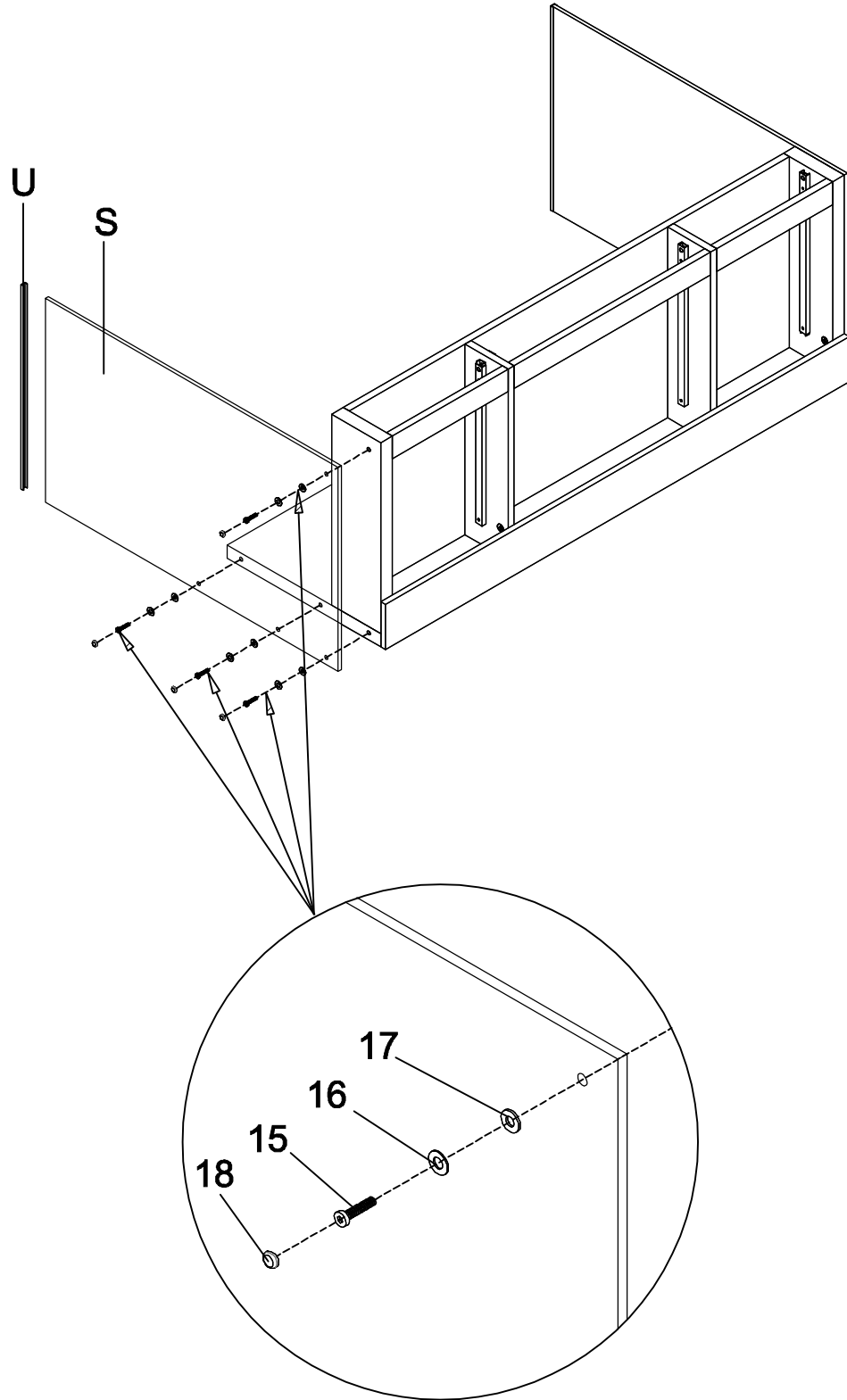

ASSEMBLY INSTRUCTIONS

STEP 15

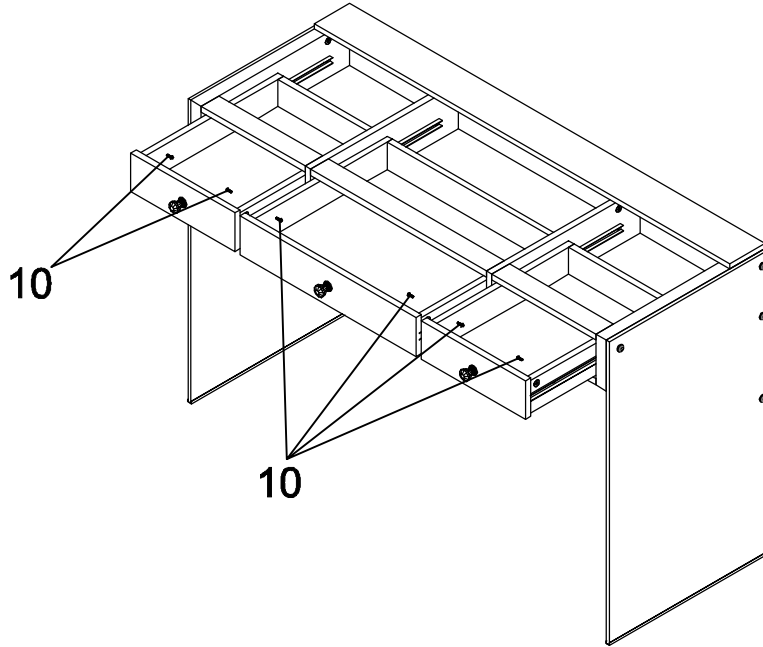

STEP 16

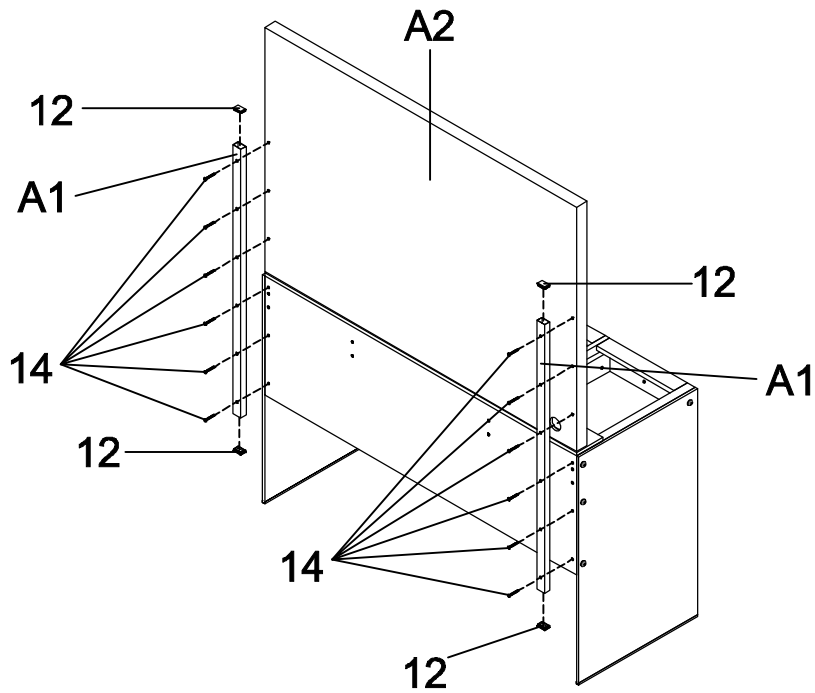

ASSEMBLY INSTRUCTIONS

STEP 17

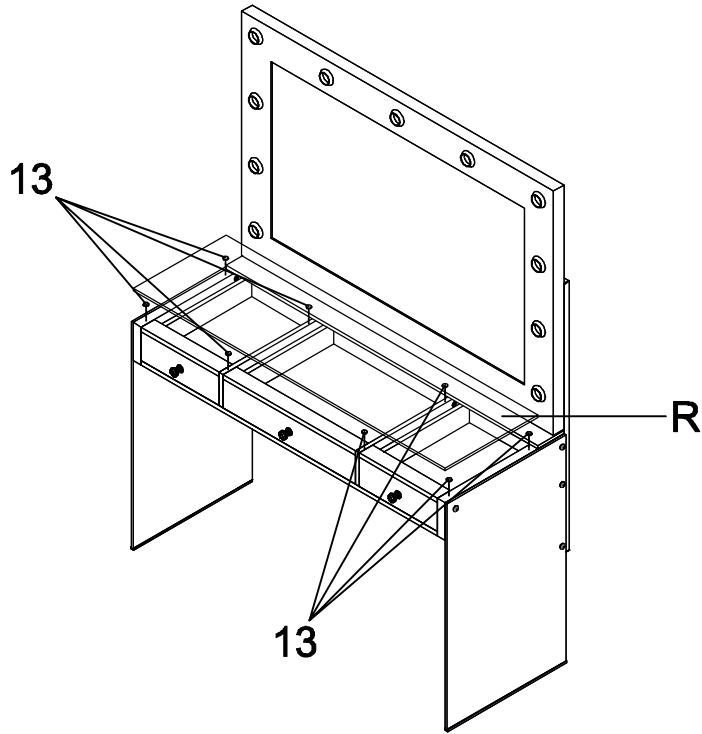

STEP 18

COMPLETE

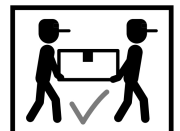
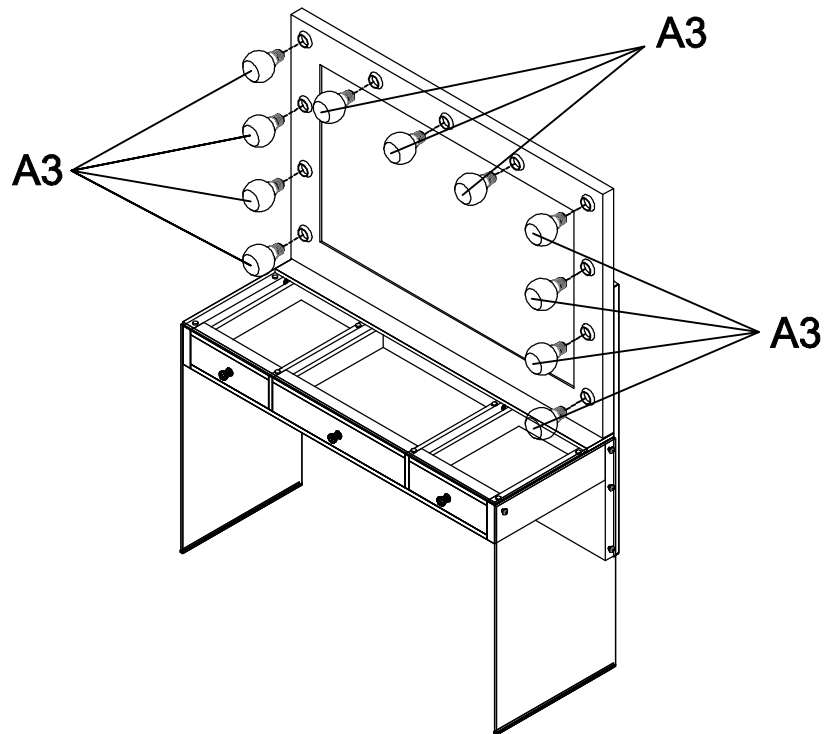

ASSEMBLY INSTRUCTIONS

Product Size : 1194 X 476 X 1565 H (MM)
Product Size : 47" X 18.75" X 61.5"

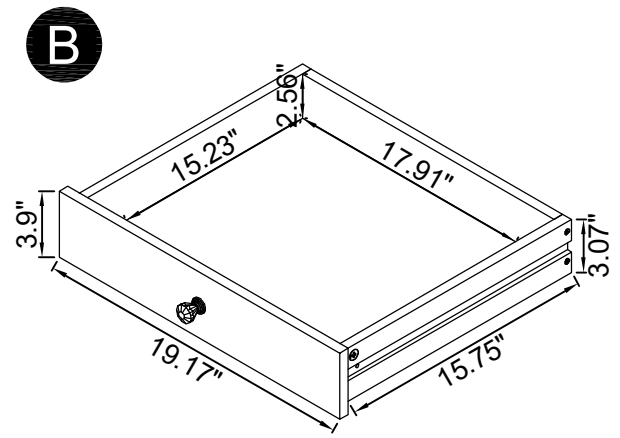
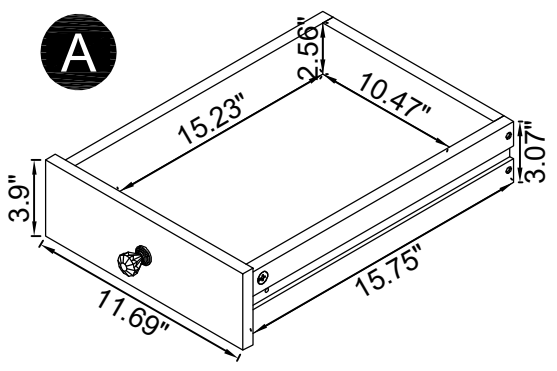
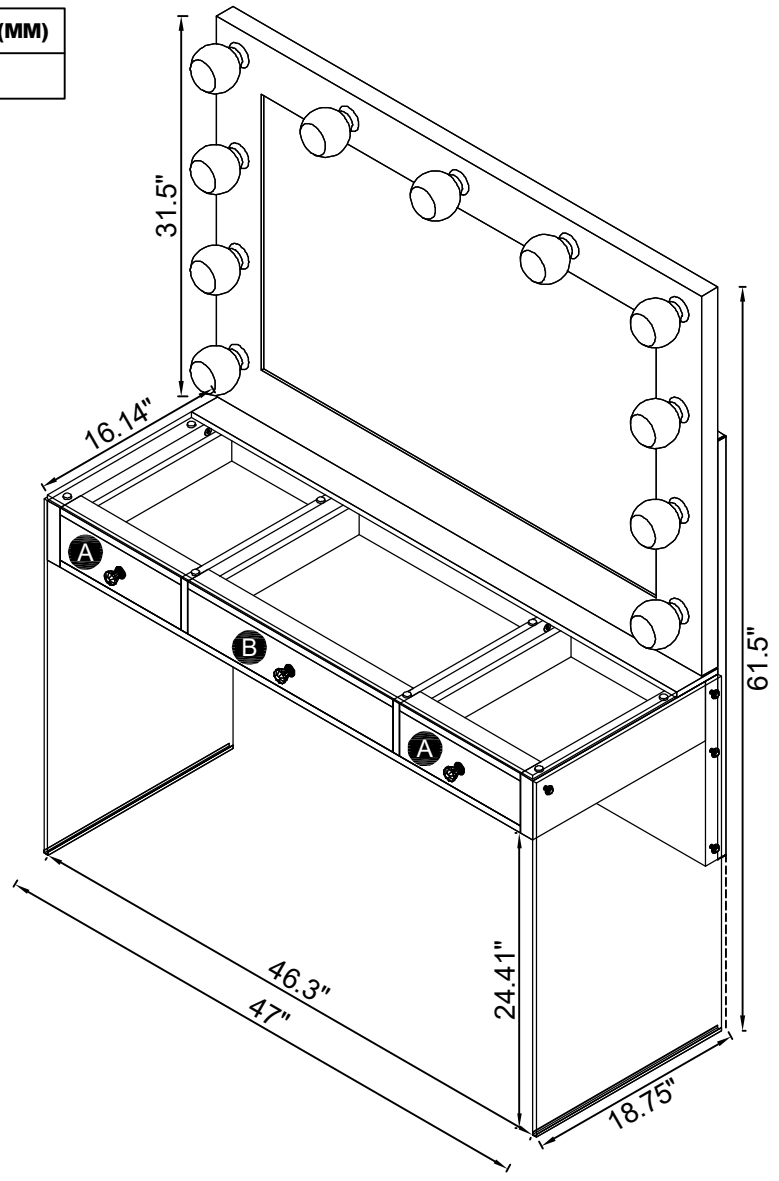

Note : Dimension tolerance $\pm 5\%$

ANTI-TIPPING INSTALLMENT INSTRUCTIONS

FURNITURE TIPPING RESTRAINT

WARNING

Injury may result from tipping furniture.
This restraint may protect against tipping furniture.
Do not allow children to climb on furniture.
This restraint is not a substitute for proper adult supervision.
Failure to detach this restraint before moving the furniture may result in injury and damage.

This tip restraint must be attached to a wall stud using long screw enclosed.

STEP 1

Attach a bracket securely to the back top rail of the furniture using short screw provided, through the smaller hole.

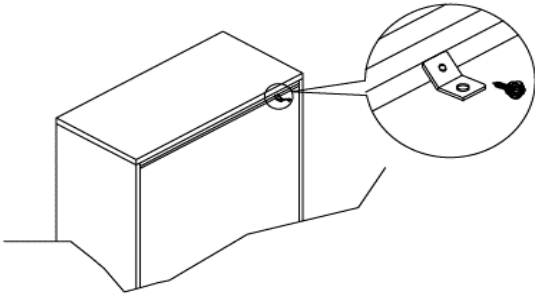

STEP 2

Locate the other bracket on the wall over a plastic wall stud and two inches below the mounting bracket secured to the back of the furniture. Attach the wall stud using the long screw provided, through the smaller hole.

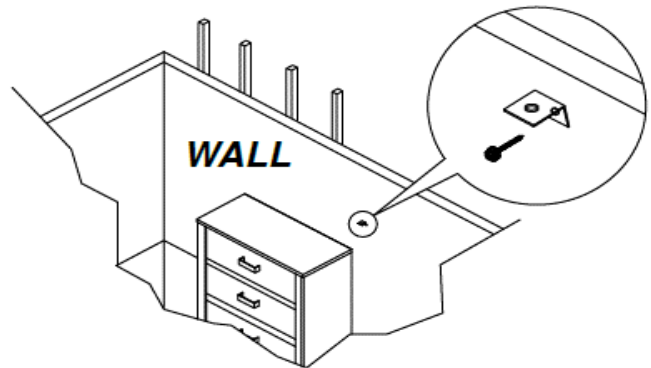

STEP 3

Place the furniture into position so both mounting brackets are vertically in line. Lace the end of the restraint strap through the larger hole in each mounting bracket. Bring both ends together and slide the flat end through the locking end and draw it through until all slack is removed. Confirm that the strap is securely laced and locked.

