

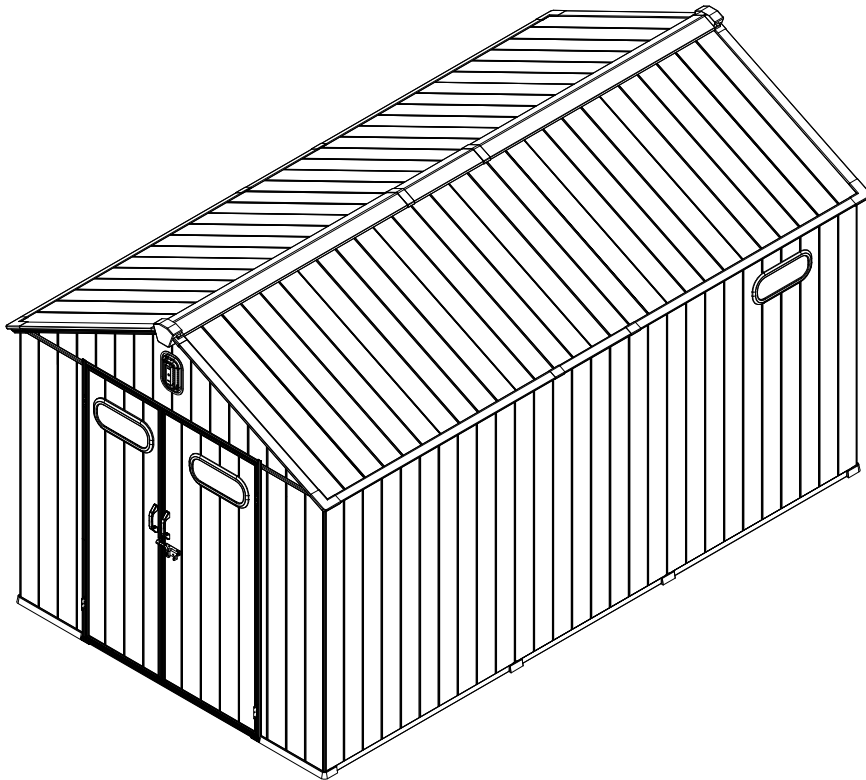

# 8'x14'

## Outdoor Storage Shed

### **ASSEMBLY MANUAL**



**MODEL#:LGCZ1778**

Missing part? Damaged? Contact us via email at

[service@domioutdoorliving.com](mailto:service@domioutdoorliving.com)

[www.domioutdoorliving.com](http://www.domioutdoorliving.com)

© Copyright 2023–2025 domi LLC. All Rights Reserved.

# STOP

Missing Parts, Questions on Assembly?

Email me: [service@domioutdoorliving.com](mailto:service@domioutdoorliving.com)

Do not return to dealer they are not  
equipped to handle your requests.

We will reply to you within 1 business day.

## PLAN AHEAD

Before beginning installation, check local building codes regarding footings, location and other requirements.

Study and understand this instruction.

Important information and helpful tips will make your installation easier and more enjoyable.

**Tools and Materials:** There are some basic tools and materials you will need for the installation. Decide which method of anchoring and the type of foundation you wish to use in order to form a complete list of the materials you will need.

## BEFORE YOU BEGIN

**Assembly Instruction:** Instructions are supplied in this manual and contain all appropriate information for your installation. Review all instructions before you begin, and during assembly, follow the step sequence carefully for correct results.

**Parts List:** Check to be sure that you have all the necessary parts and quantities in your package. These are packaged within the carton. Note that extra fasteners have been supplied for your convenience.

**Explosion Diagram:** All parts except screws and bolts are shown in this diagram, review all parts before you begin. Familiarize yourself with the hardware and fasteners for easier use during installation.

## ***Pre-assembly***



1. Two or more people are required for assembly.



2. You will need one or more stepladders.



3. Wearing protective gloves is recommended.



4. You may need a safety hat.



5. Please use a Phillips screw driver.



6. For ease of construction, you may need a drill.



7. You may need a safety goggle.



8. Do not fully tighten screws prior to complete assembly.

## ***Warning & Attention***

-Try to assemble this product on the flat ground, otherwise it is difficult to carry out;

-It would be much easier to assemble the product with three or more people;

-Gaskets must be used.

-After assembly, please check whether all screws are tightened, to prevent parts from falling apart.

**▲** Use bolts to secure the frame to the ground to against the strong wind.

 Please stand inside the shed frame when installing the panels for convenience.

# ASSEMBLY TIPS & TOOLS

**Watch the Weather Closely:** Be sure the day you choose to install your building is dry and calm. Do **NOT** attempt to assemble your building on a windy day. Be careful on wet or muddy ground.

**Use Teamwork:** Two or more people are required to assemble your building. One person can hold the parts or panels in place while the other person fastens them together and handles the tools. This makes the process of assembling your building faster and safer.

**Tools and Materials:** Here is a list of some basic tools and materials you will need to assemble your building. Decide which method of anchoring and the type of base you will use to make a complete list of the materials you will need.

## WHAT YOU NEED

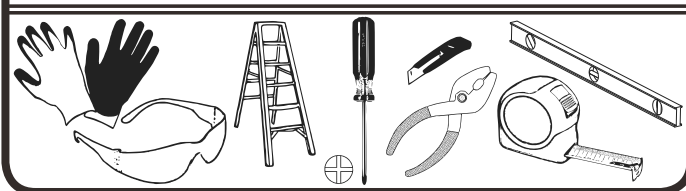

- Work Gloves
- Safety Glasses
- Step Ladder
- No. 2 Phillips Screwdriver (Magnetic Tip Preferred)
- Utility Knife or Scissors
- Pliers
- Carpenter's Level
- Tape Measure

## RECOMMENDED TIME SAVERS

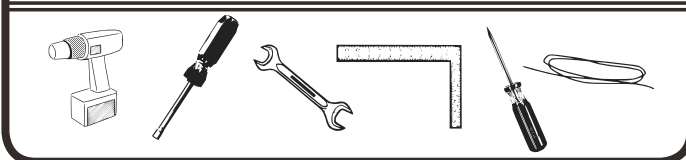

- Power Drill (Cordless, Variable Speed)
- Nut Driver or Wrench
- Square
- String (for squaring the frame)
- Awl (to align holes)

## BASE PREPARATION TOOLS

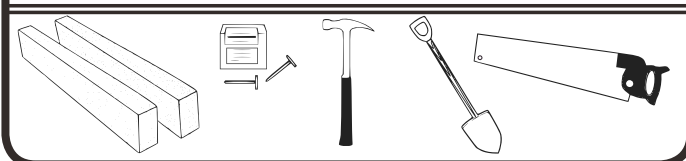

- Lumber and/or Concrete
- Hammer and Nails
- Spade or Shovel
- Hand Saw or Power Saw

**How to Select and Prepare Your Building Site:** Before you start to assemble your building, you will want to decide on a good location. The best location is a level area with good drainage.

- Allow enough working space so it is not difficult to move parts into position for assembly. Be sure there will be enough space at the entrance for the doors to completely open. Also, there needs to be enough space outside the building to be able to fasten the panel screws from the outside.
- Before assembling any parts, your base should be constructed and an anchoring system should be ready to use.

# SAFETY PRECAUTIONS...

*Safety precautions MUST be followed at all times throughout the construction of your building!*

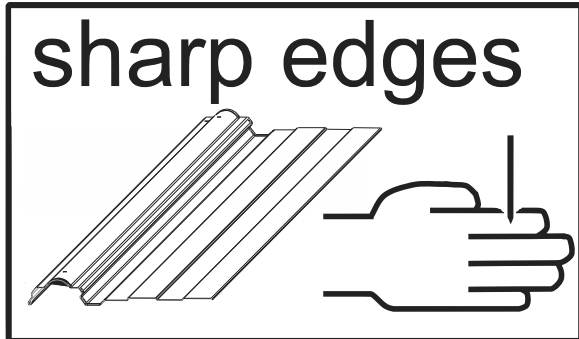

Care must be taken when handling various pieces of your building since many contain sharp edges. Please wear work gloves, eye protection and long sleeves when assembling or performing any maintenance on your building.



Practice caution with the tools being used in the assembly of this building. Be especially familiar with the operation of all power tools.



Keep children and pets away from the worksite during construction and until the building is completely assembled. This will help avoid distractions and any accidents which may occur.







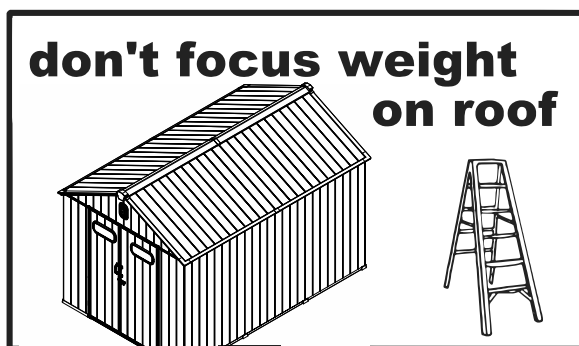





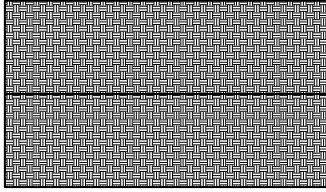



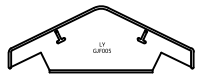
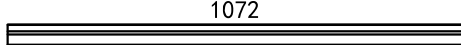
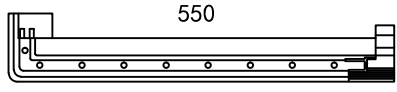
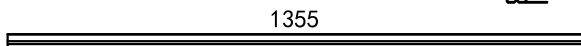
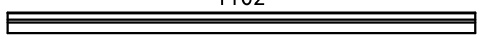
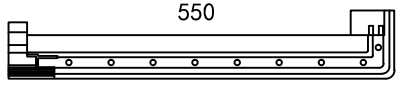





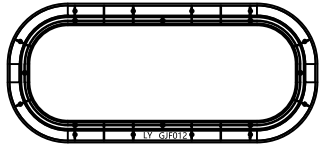

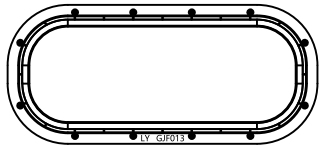
Do NOT attempt to assemble your building on a windy day. The large panels can catch the wind like a "sail", causing them to be whipped around making construction difficult and unsafe.

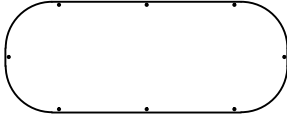
Do NOT attempt to assemble your building before double checking that you have all the parts indicated in the parts lists as well as all hardware. Any building left partially assembled may be seriously damaged by even light winds.

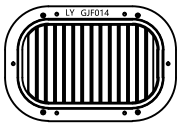

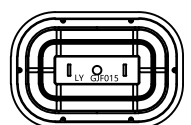
NEVER concentrate your weight on the roof of the building. When using a step ladder make sure that it is fully open and on even ground before climbing on it.

	GJF001-x2		GJF016-x2
	GJF002-x2	 <p>4006 (8'X14')</p> <p>2306</p>	Ah - x1
	GJF003-x2		
	GJF004-x4		A - x1
	GJF005-x2		A1 - x2
	GJF006-x1		A2 - x4
			A3 - x2
	GJF007-x1		B - x4
	GJF010-x2		B1-x1
	GJF011-x5		B2-x1
	GJF012-x4		B3-x13
	GJF013-x4		B4x2
	R - x4		B5x16
	GJF014-x2		B6x4
	GJF015-x2		B7x2

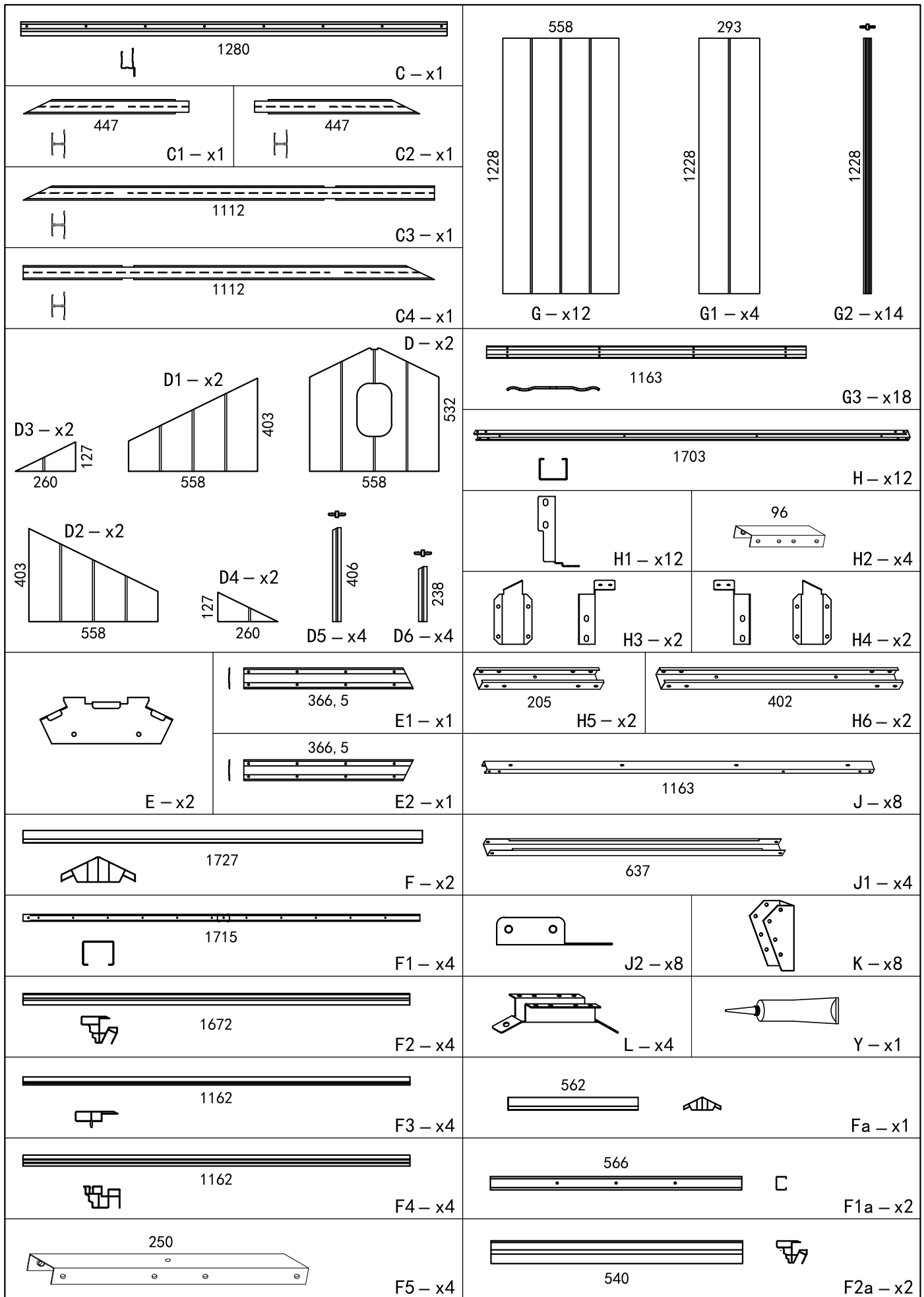

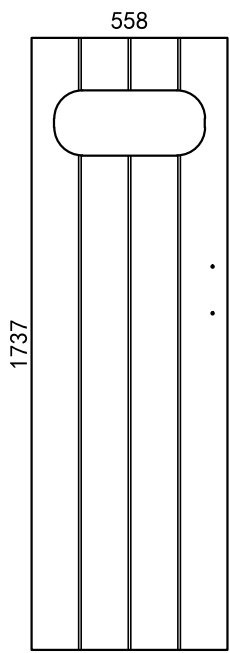

M1 - x1

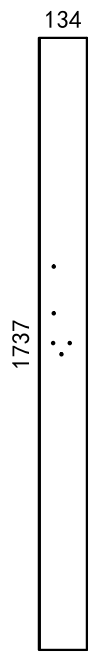

M3 - x1



M4 - x1

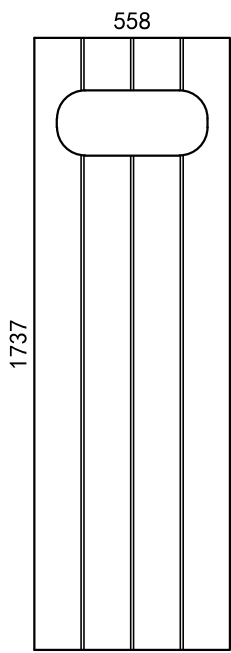

M2 - x1

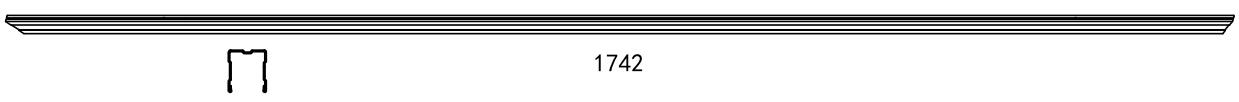

1742

N - x2

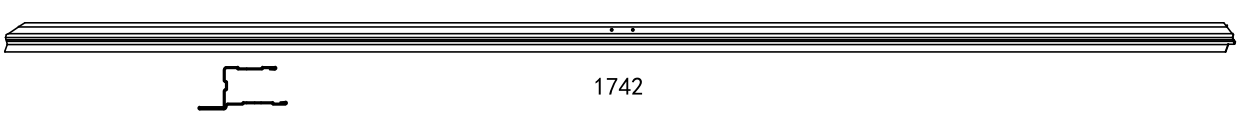

1742

N1 - x1

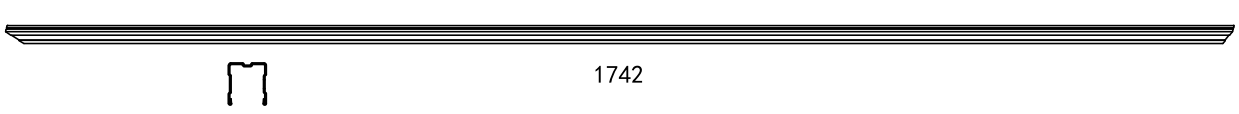

1742

N2 - x1

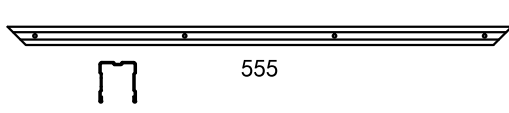

555

N3 - x2

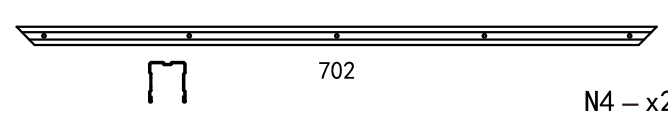

702

N4 - x2

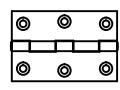

HY - x4

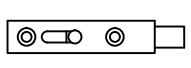

CX - x2

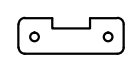

P - x1

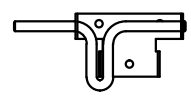

Q - x1

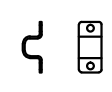

Q1 - x1

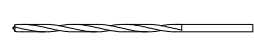













Ø3

Q3 - x1

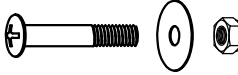

Ø5.5

Q4 - x1

	M5x8	1# - x96
	M5x16	2# - x12
	M5x38	3# - x72
	4x28	4# - x50
	5x14	5# - x82
	4x14	6# - x154
	4x14	7# - x434
	4x12	8# - x12
	3x8	9# - x32
	3x19	10# - x48
	M5x28	12# - x4
	M5x25	13# - x5
		14# - x12

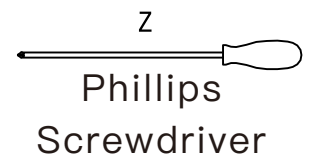
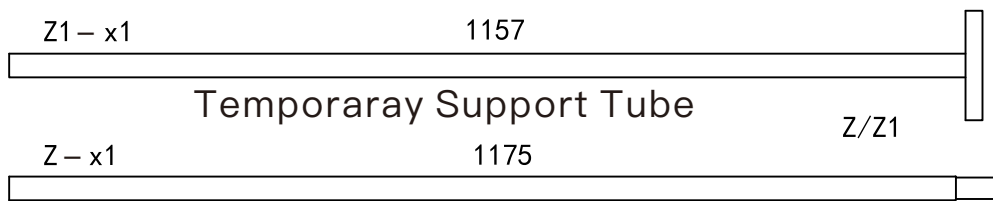

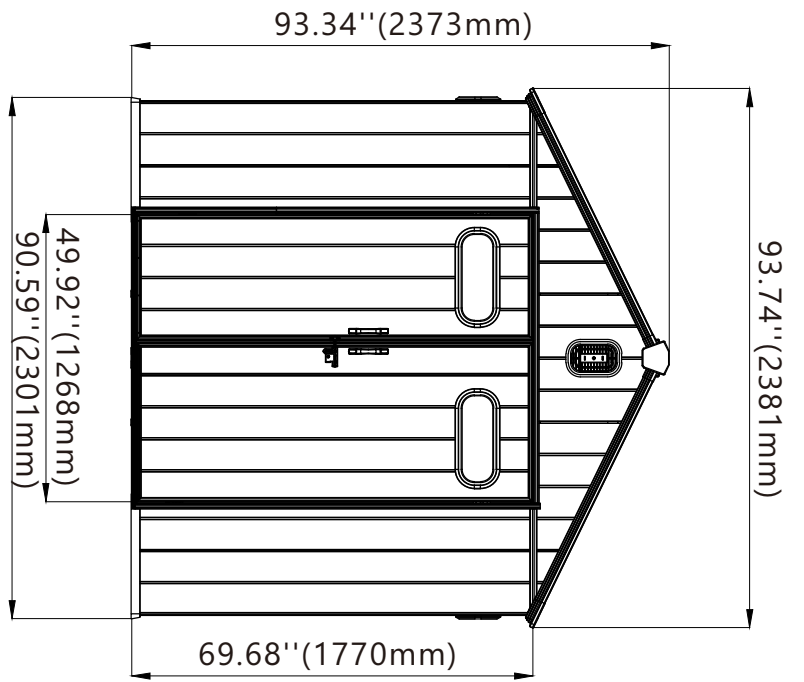
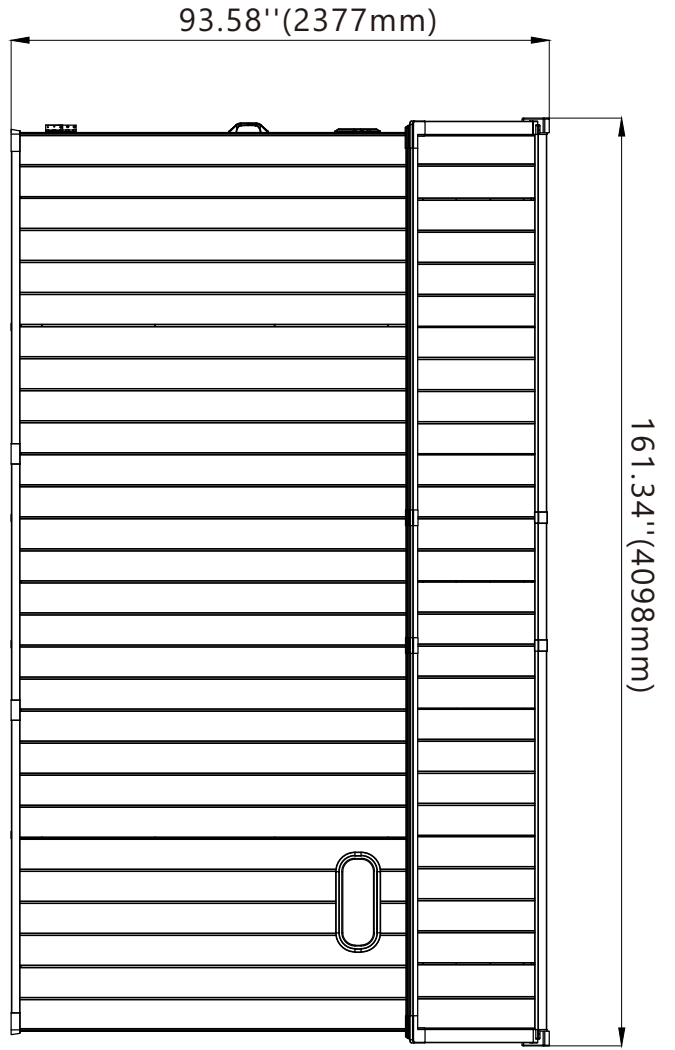
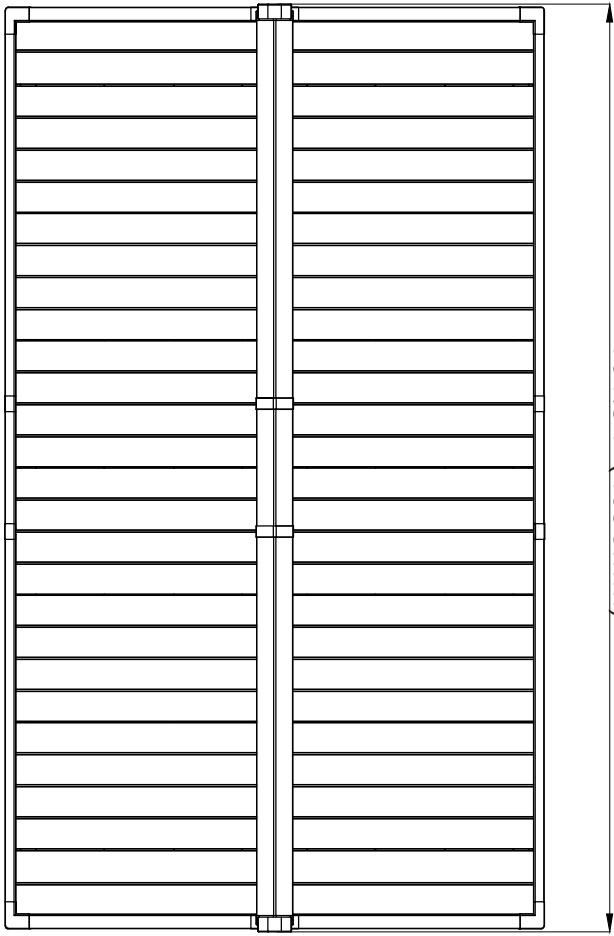

# THE BASE FOR YOUR BUILDING

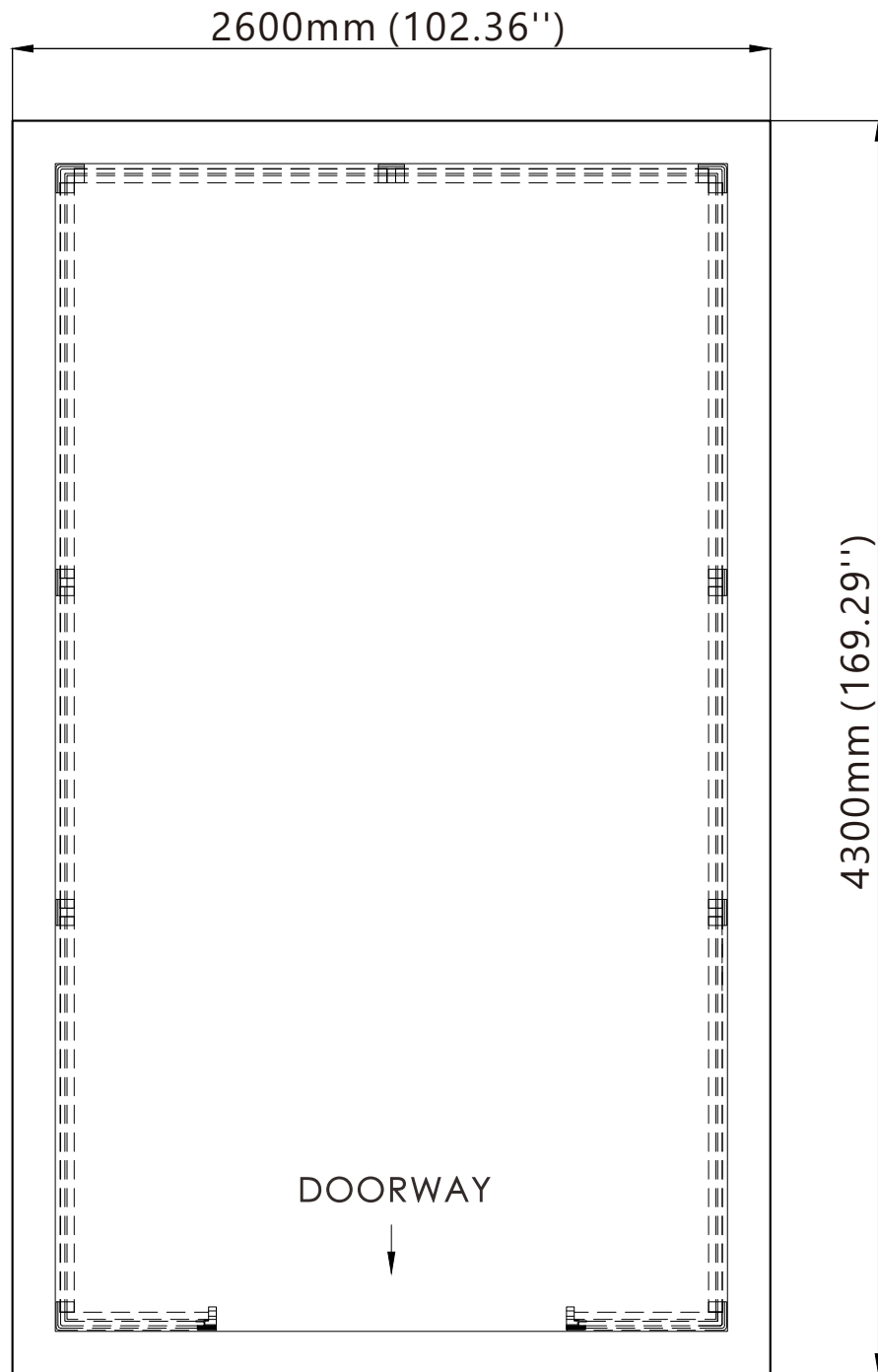

1. Leveling the ground.

2. Set up the base: It is recommended to build a wooden base or concrete base.

Foundation Requirements:

(1) The area of the foundation should not be less than the size range in the figure.

(2) The thickness of the concrete should not be less than 7cm.

(3) The base surface must be measured by the spirit level to be in a flat state.

(4) The base surface must be higher than the ground to prevent water accumulation.

Lay the carpet on the foundation

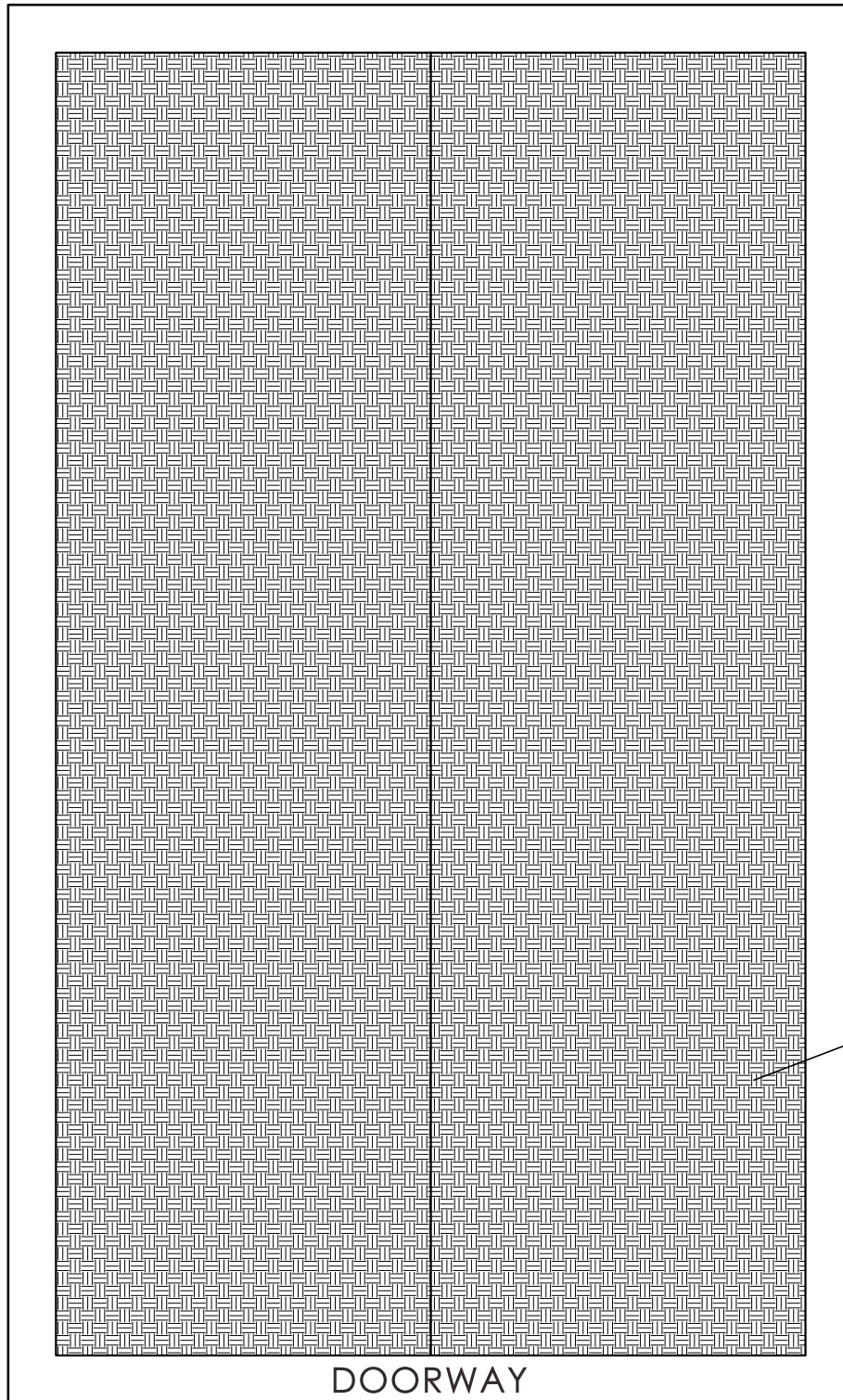

1778 (8'X14')- LAY THE CARPET



GJF006-x1



GJF007-x1



GJF010-x2



GJF011-x5



A - x1

1251

1072

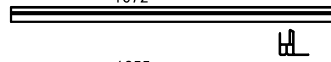

A1 - x2

1355

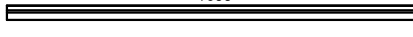

A2 - x4

1102

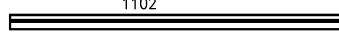

A3 - x2

# Install the Base

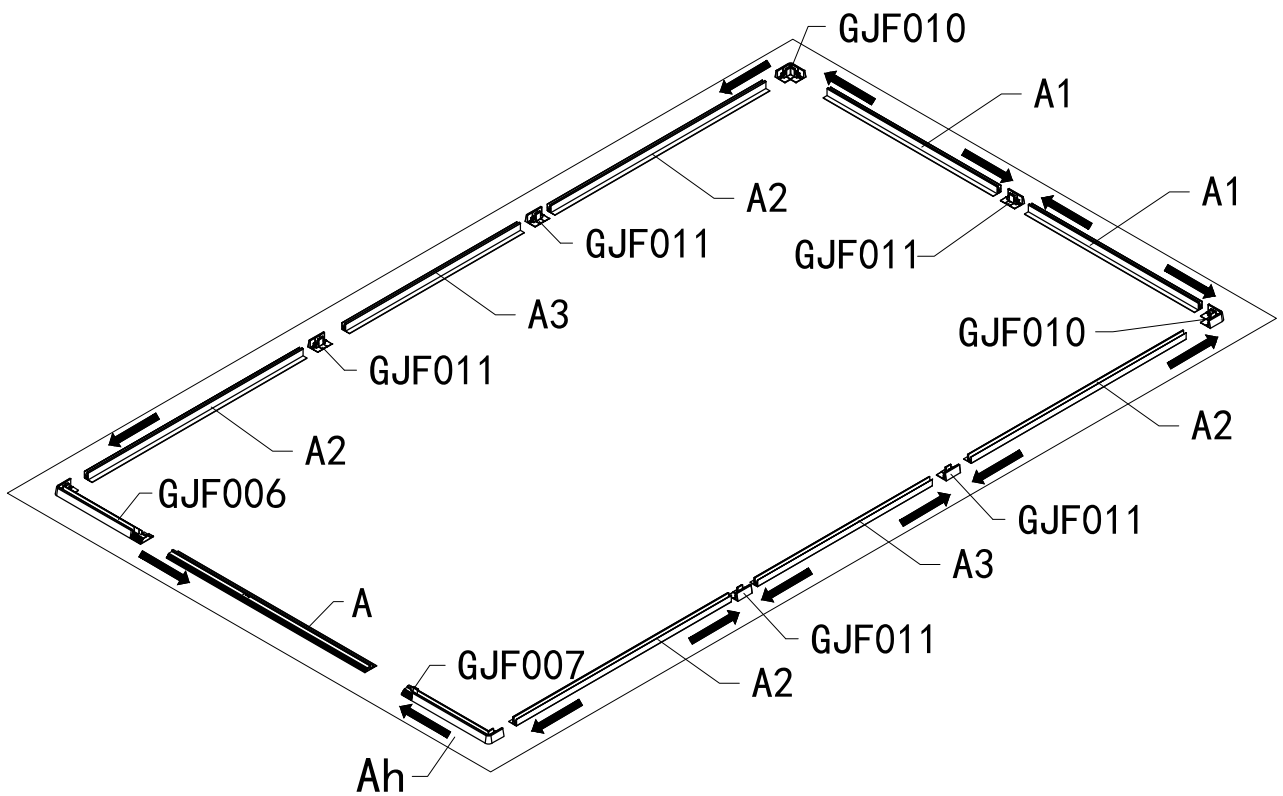

Front view of base

4x14

6# - x20

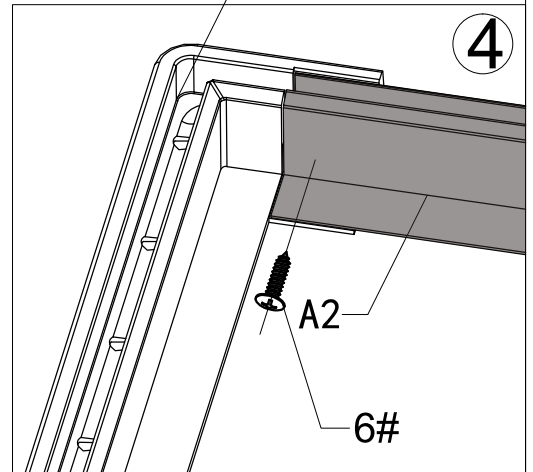
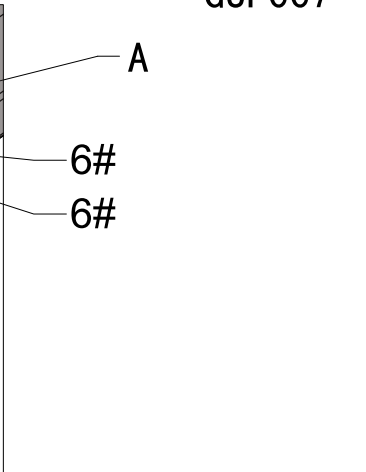
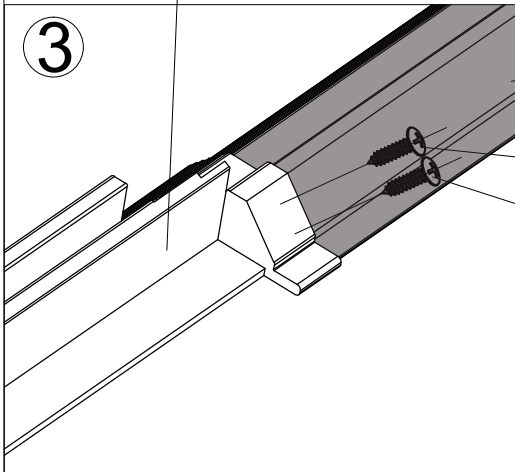
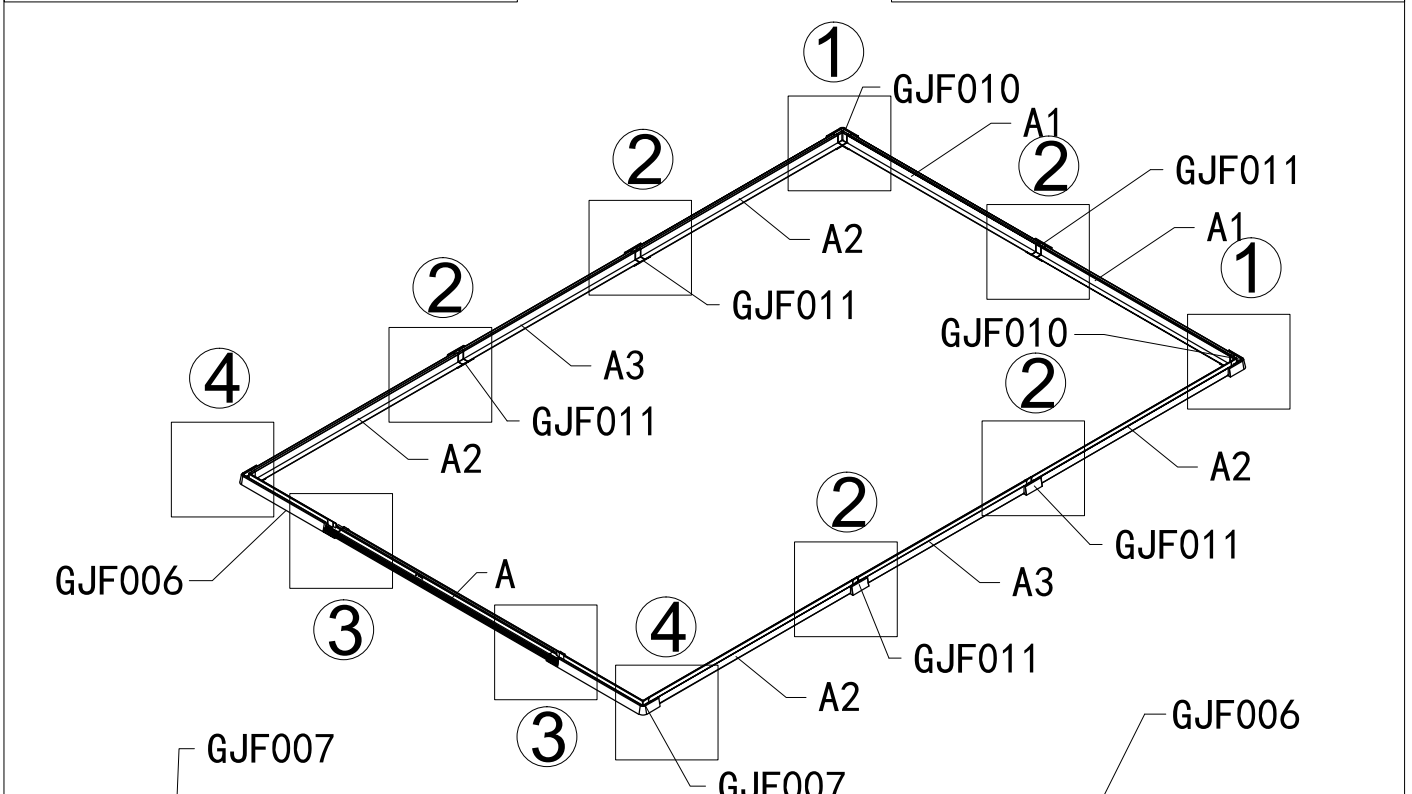
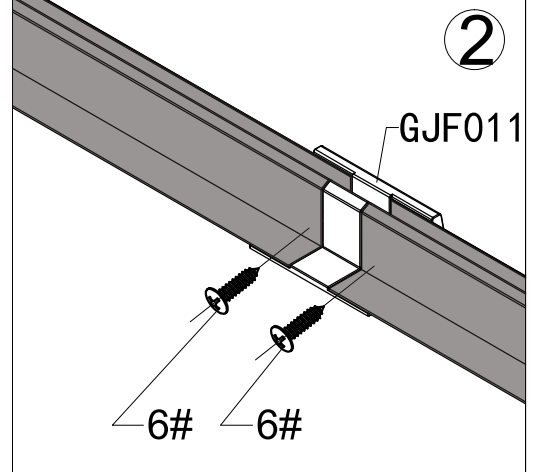
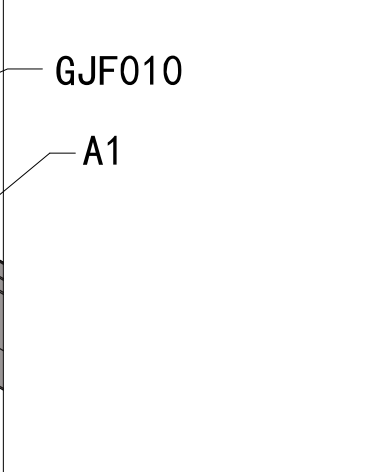
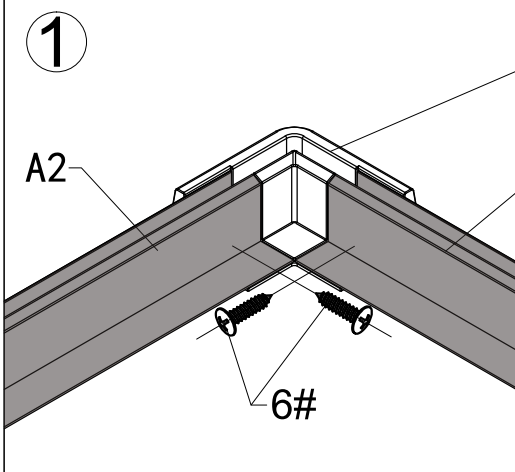

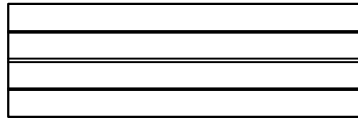

B - x4

Install the corner wall panels:

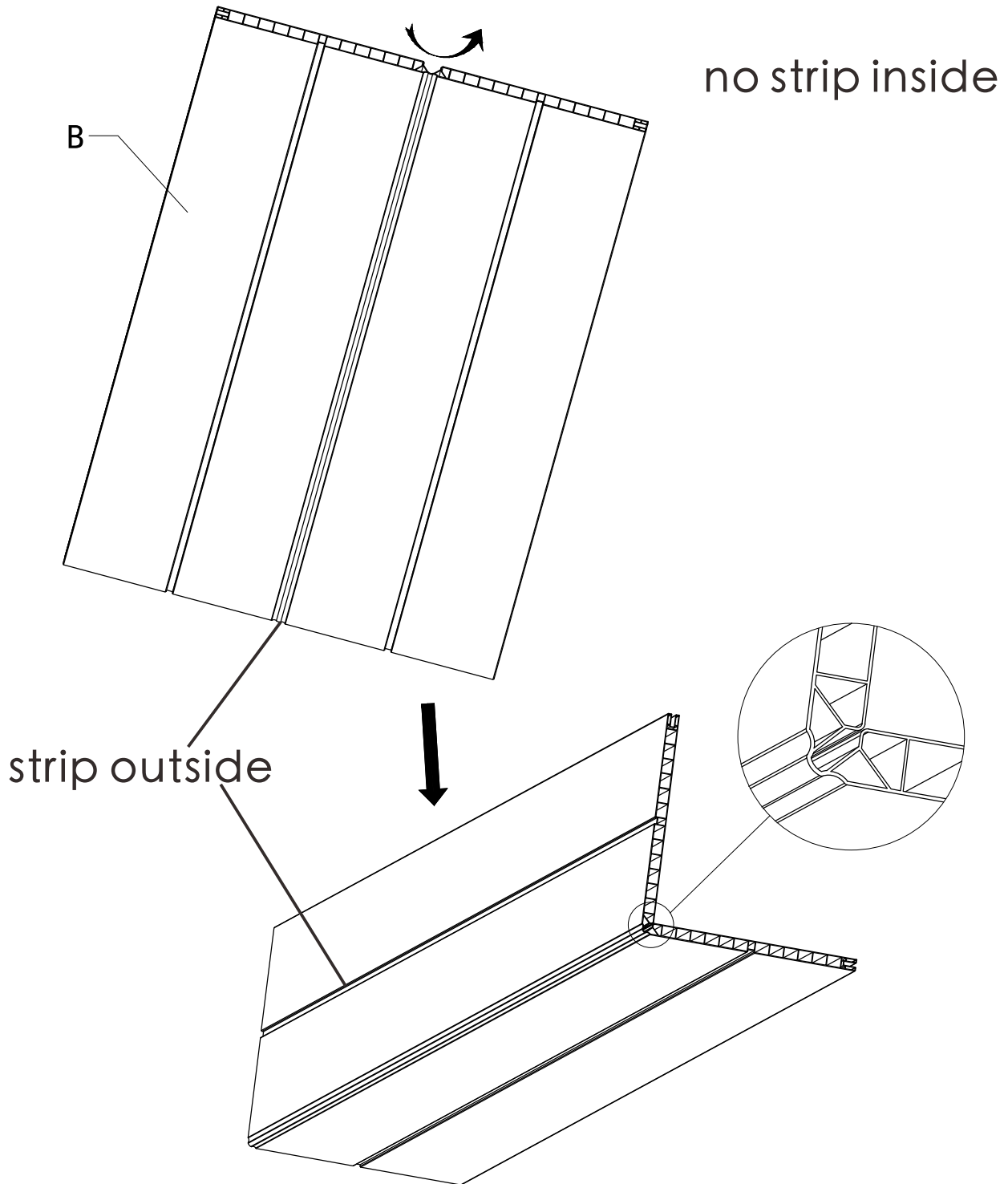

Put in the corner of the base

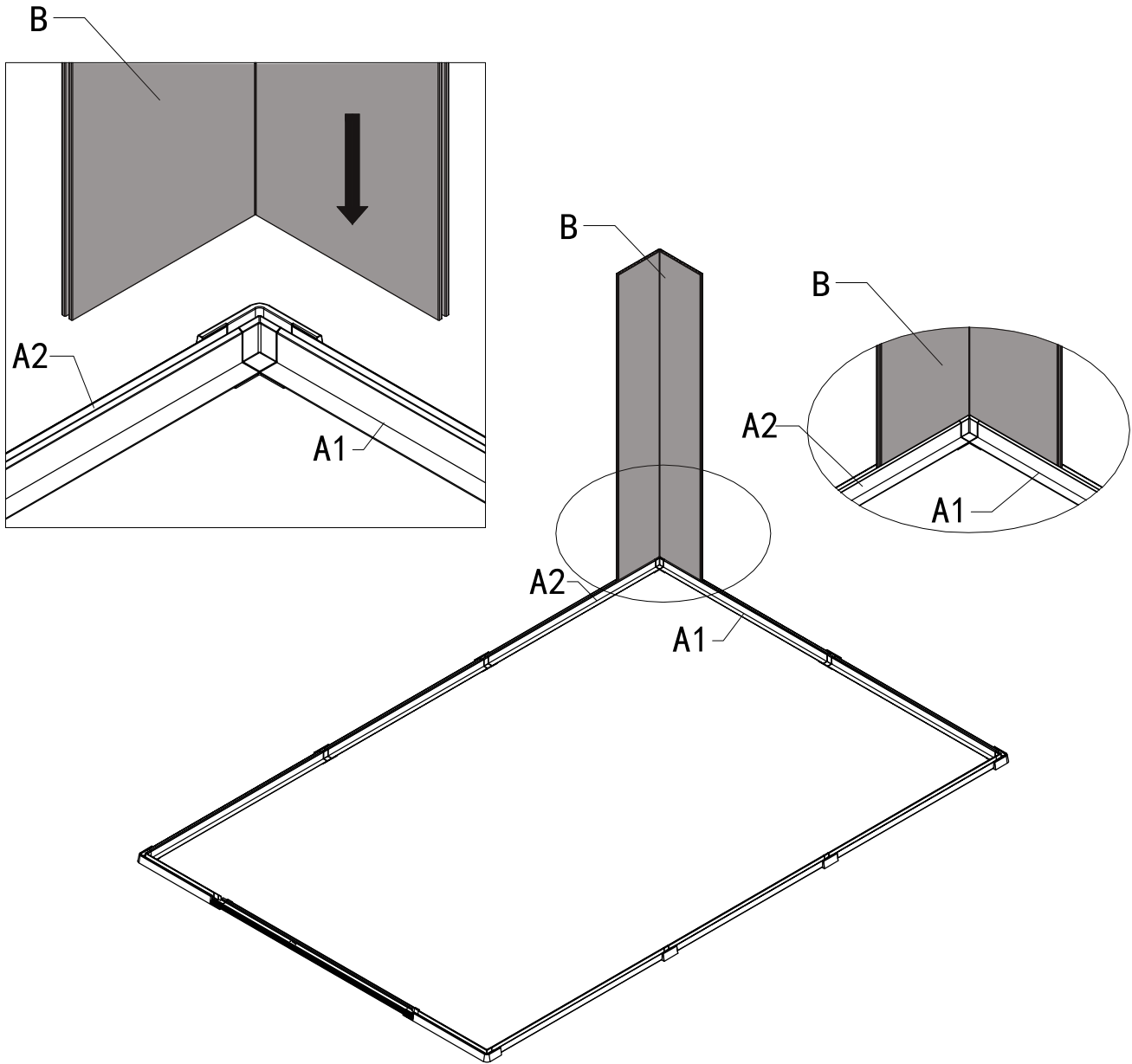

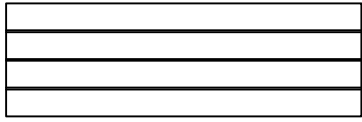

B3-x1



B6x1

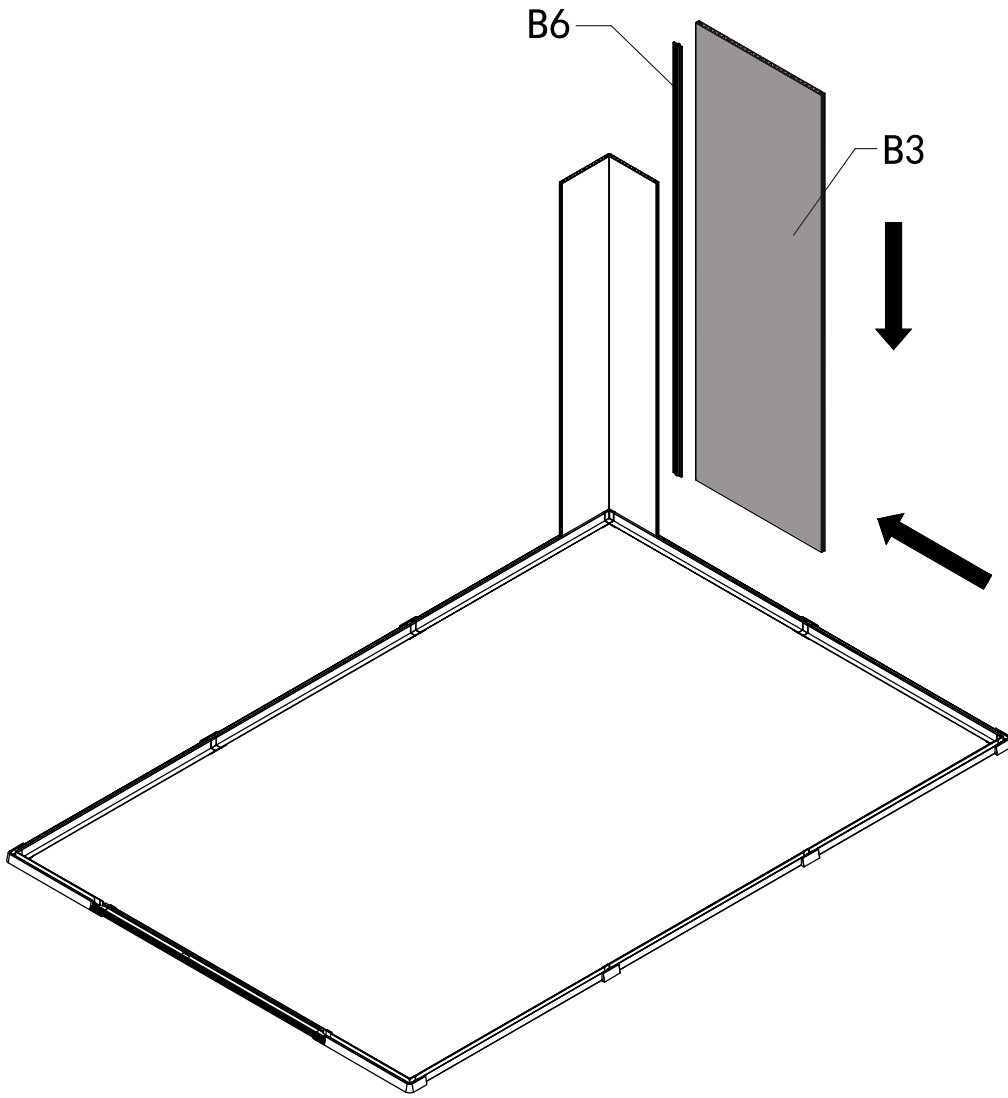

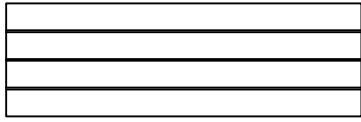

B3-x1



B5x1

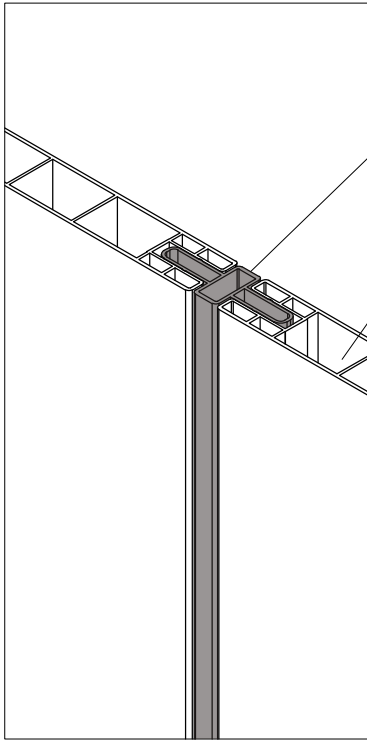

B5

B3

Note: Each panel should tightly lock to each other without any gap. Otherwise, there will not be enough space for last panel.

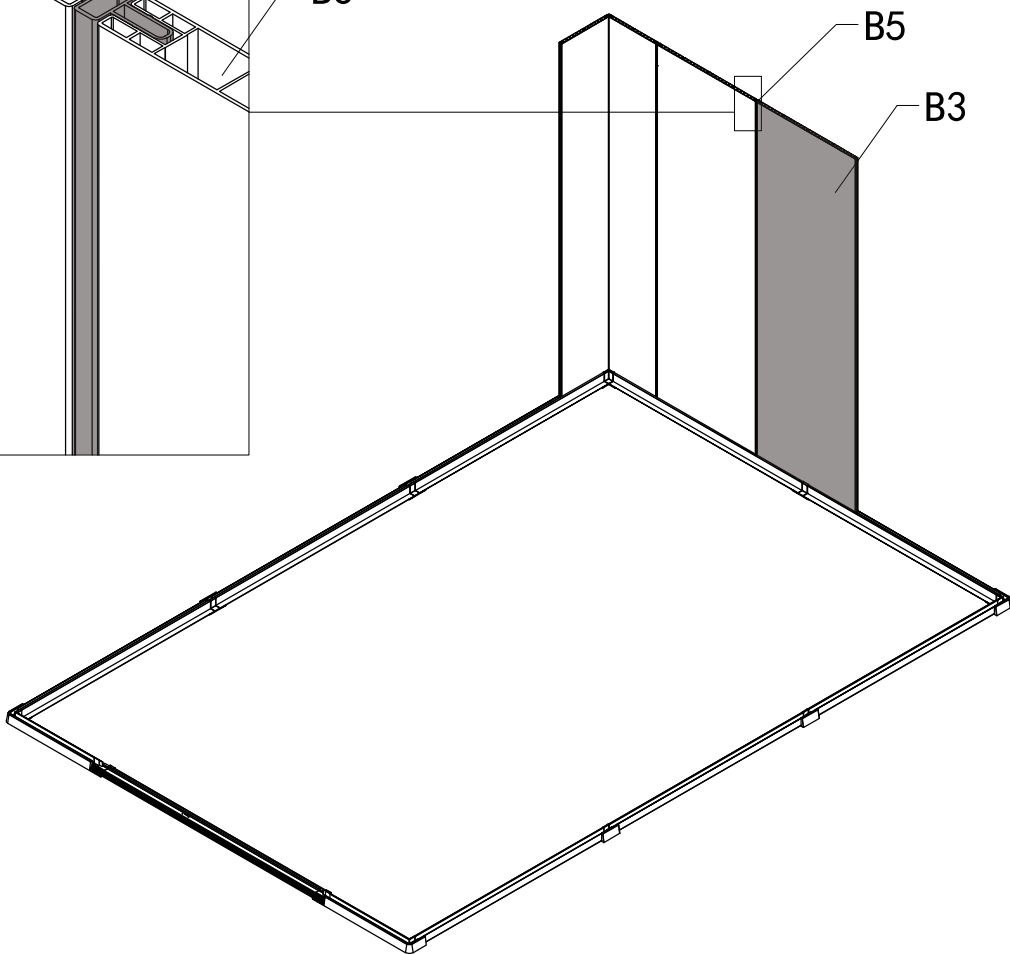

B5

B3

Note2: The installed panels are easily removed and can be secured with screws when finish one row, but make sure the panels are used correctly. Refer to Installation guide (Page 21,22 and 23).

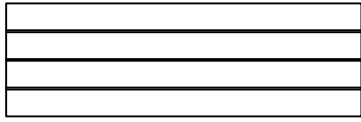

B3-x1



B5x1

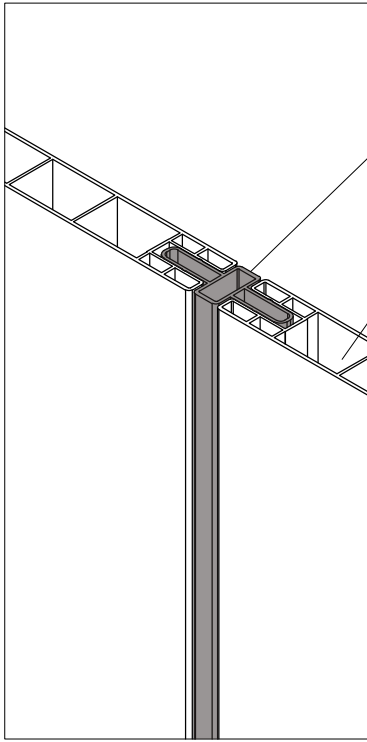

B5

B3

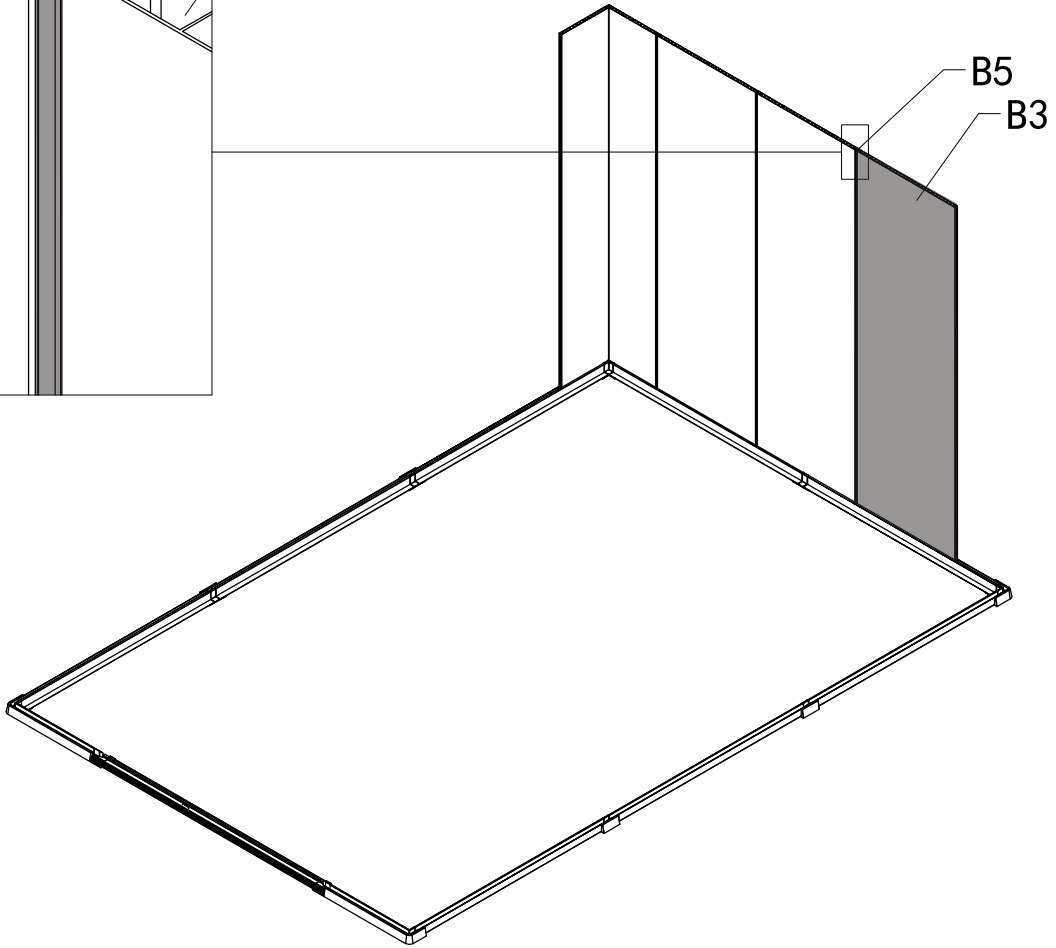

B5

B3

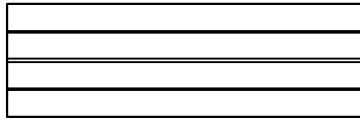

B - x1



B6x1

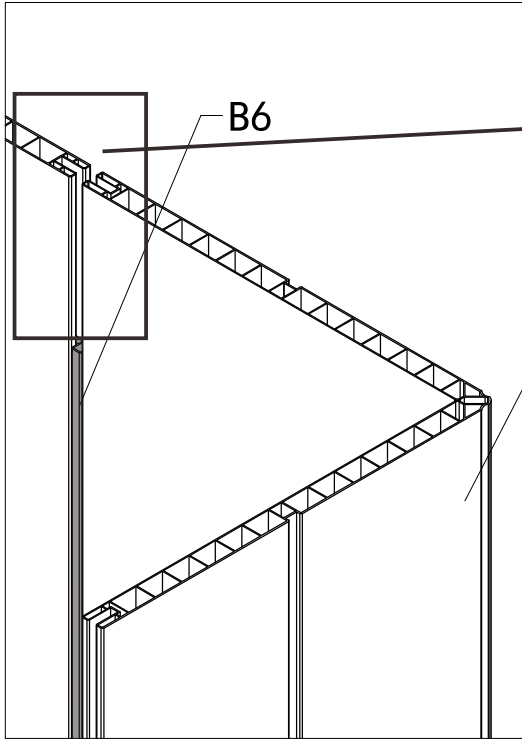

For subsequent installation needs, there is a notch in the joint of the two wall panels.

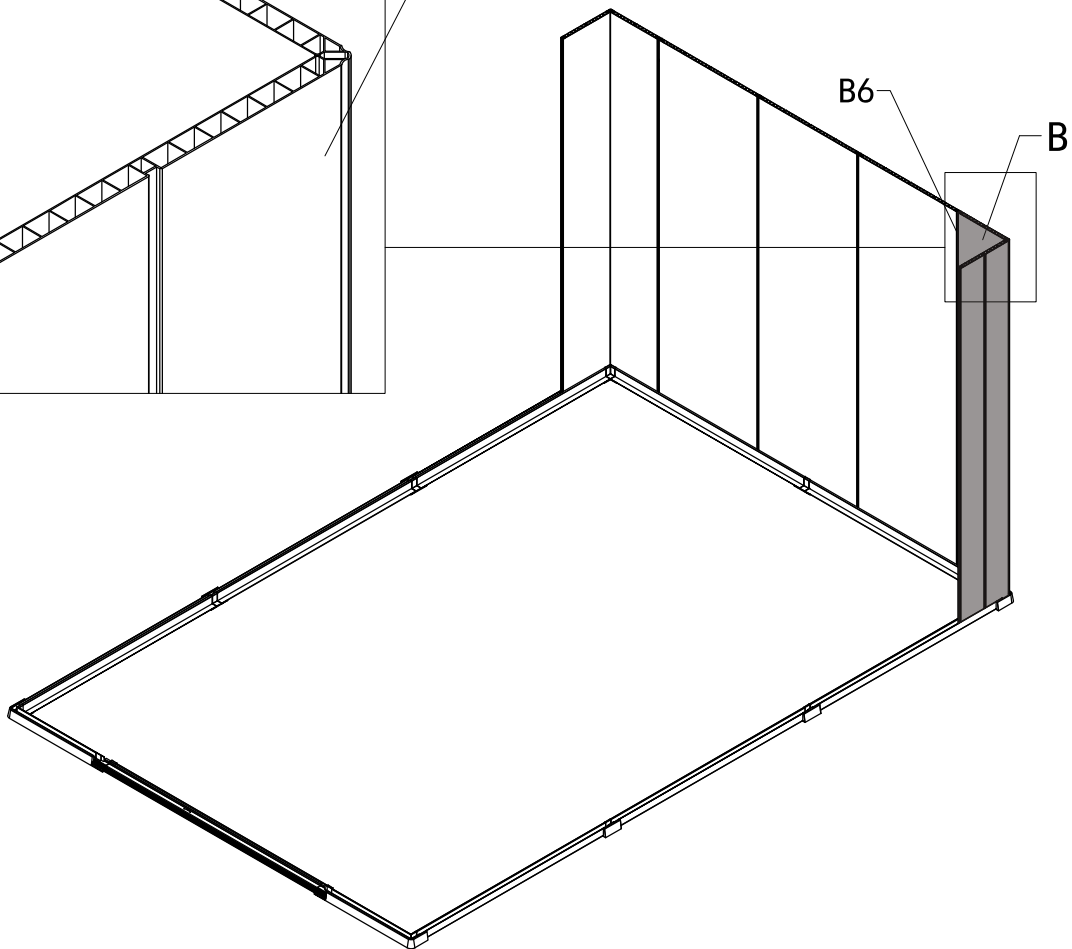

9# — x8

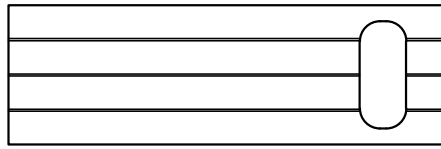

GJF012-x1

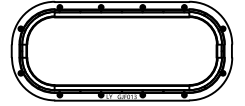

GJF013-x1

10# — x12



R-x1

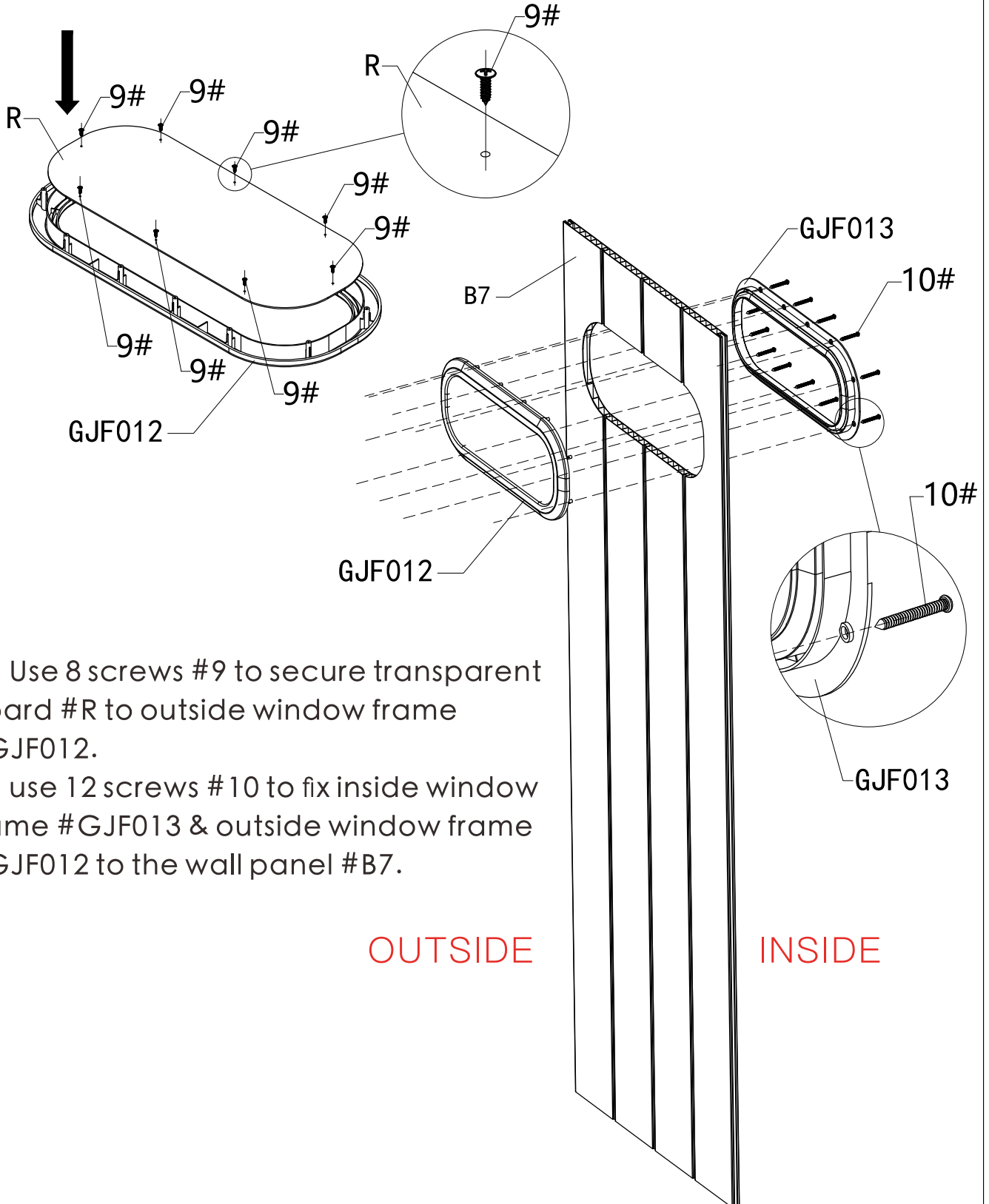

(1) Use 8 screws #9 to secure transparent board #R to outside window frame #GJF012.

(2) use 12 screws #10 to fix inside window frame #GJF013 & outside window frame #GJF012 to the wall panel #B7.

OUTSIDE

INSIDE

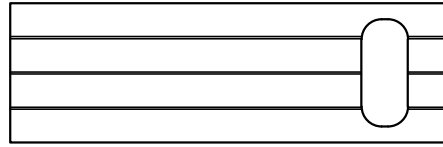

B7x1



B5x1

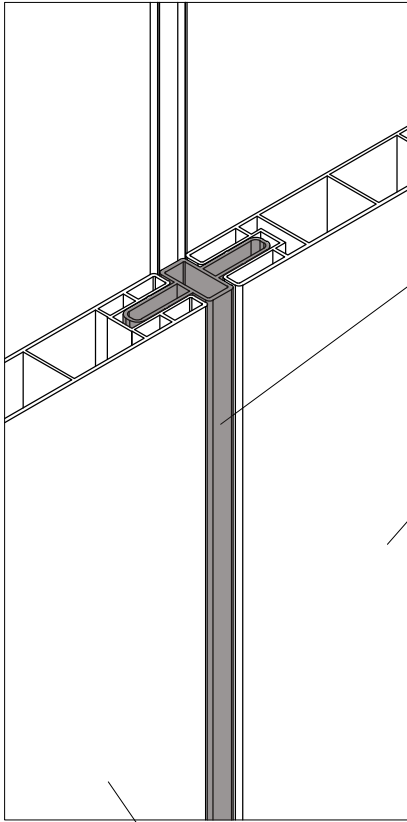

B5

B

B7

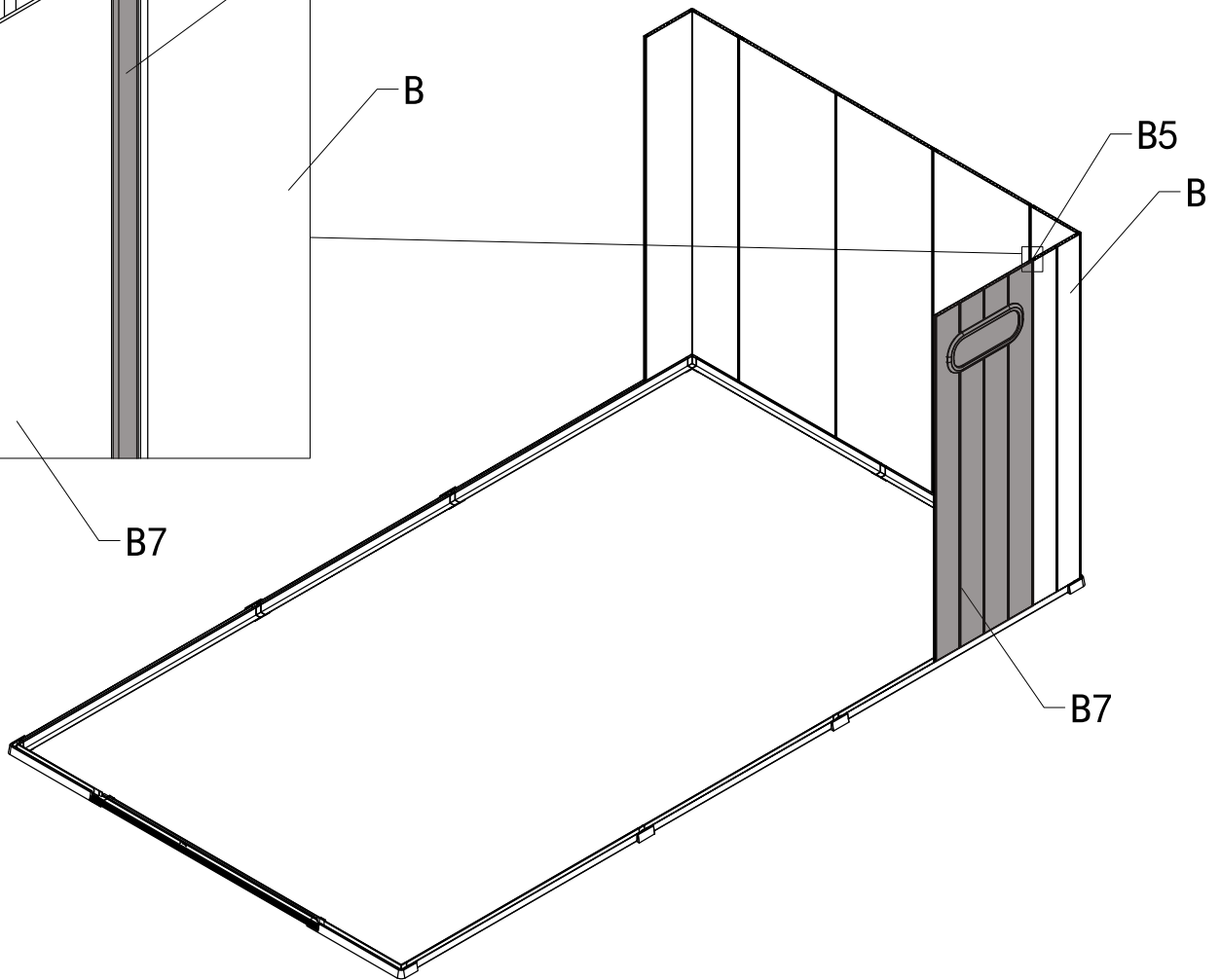

B5

B

B7



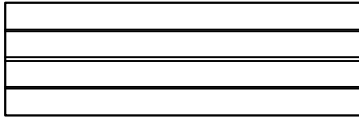

B - x1

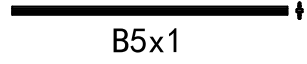

B5x1

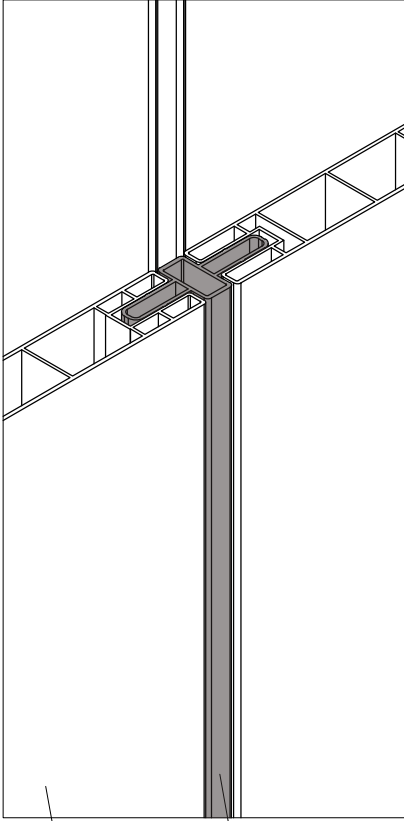

B

B5

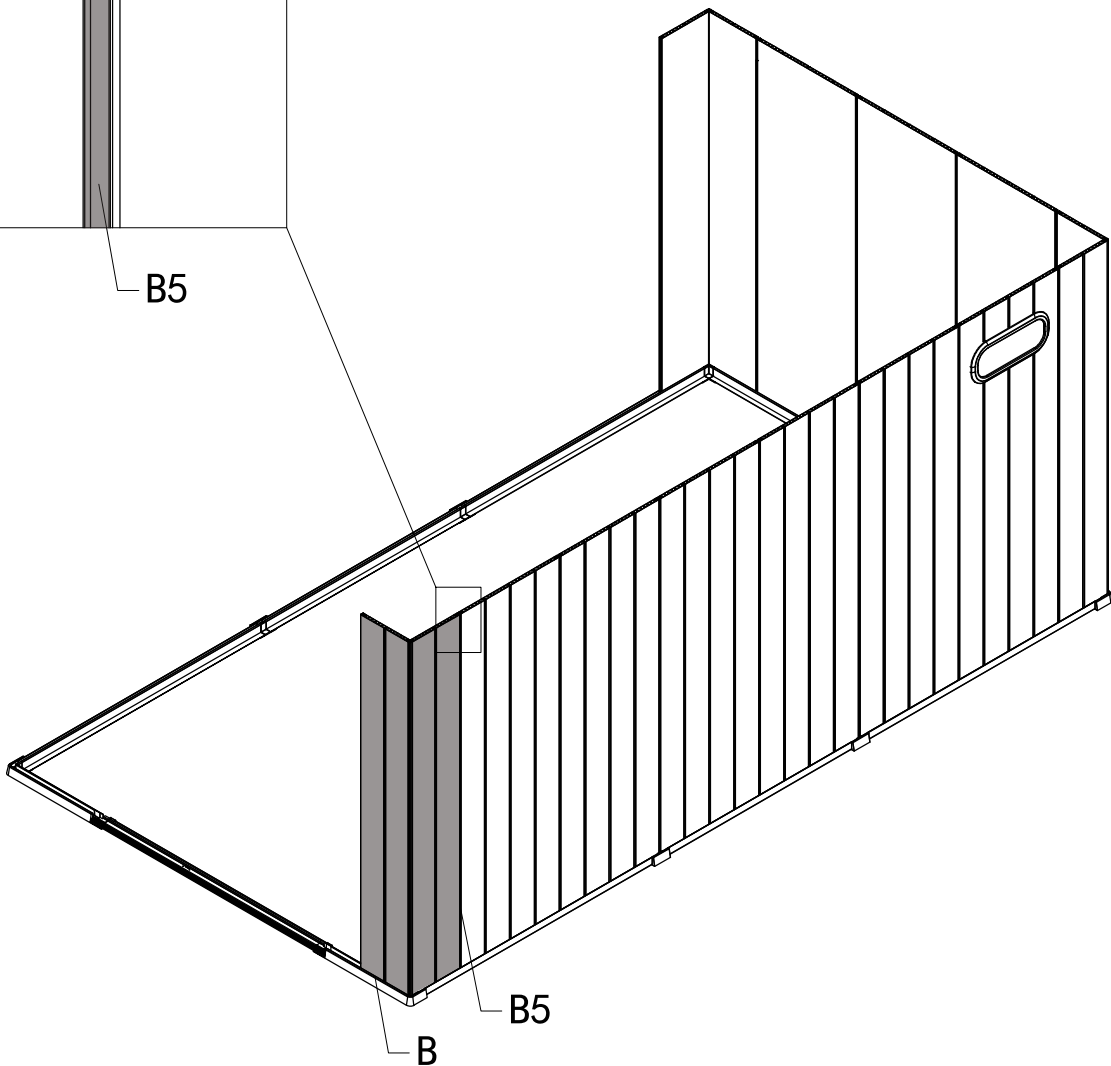

B

B5

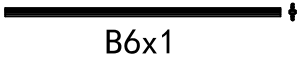

B6x1

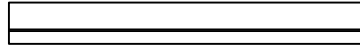

B4x1

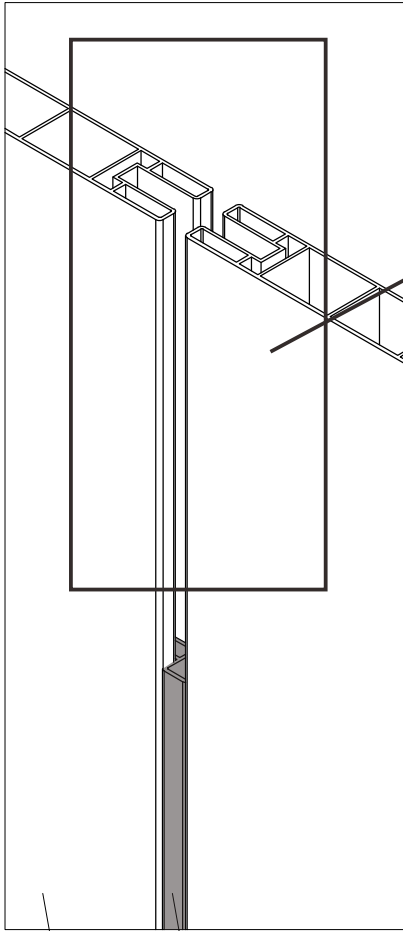

For subsequent installation needs, there is a notch in the joint of the two wall panels.

B4

B6

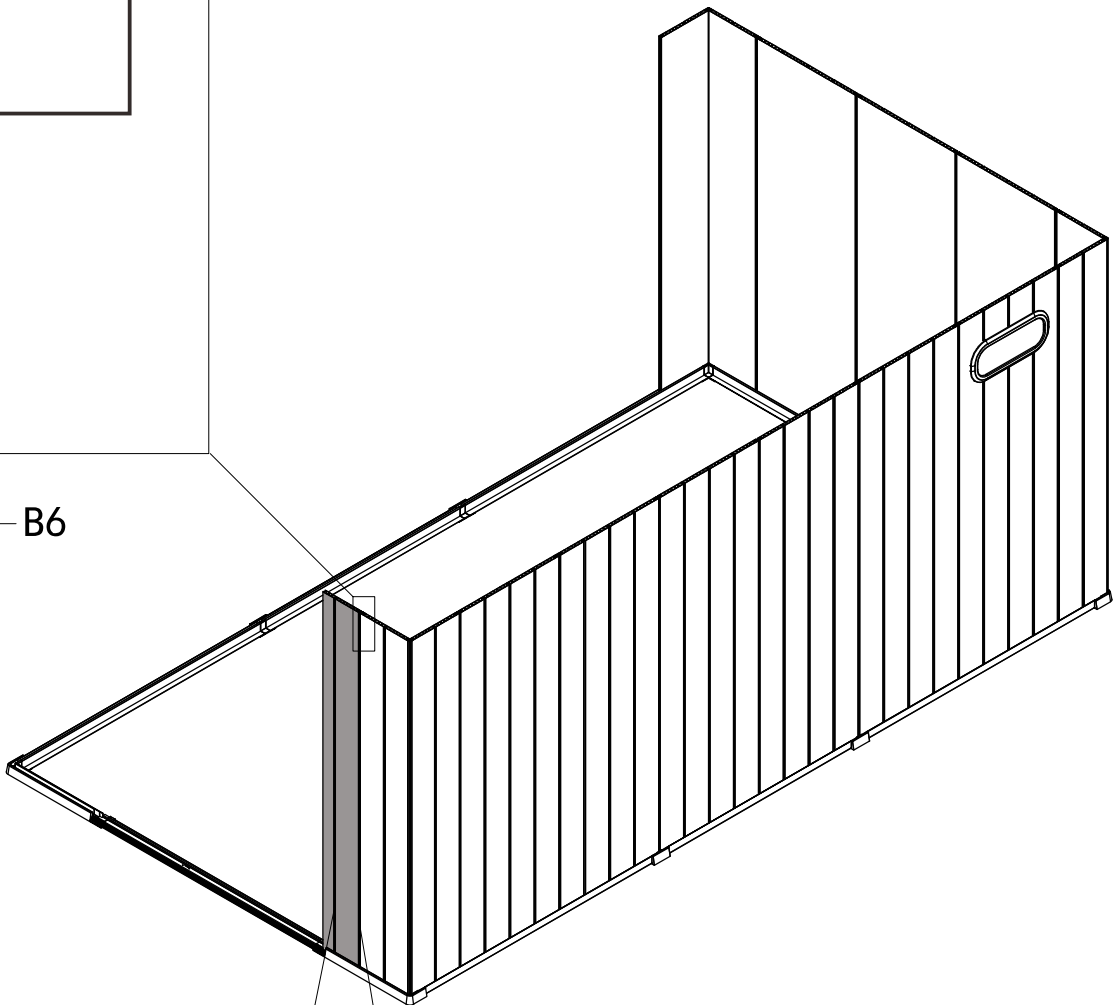

B4 B6

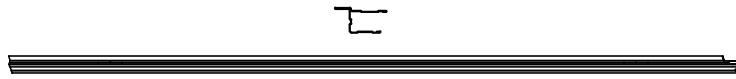

B2-x1

Insert #B2 into the base

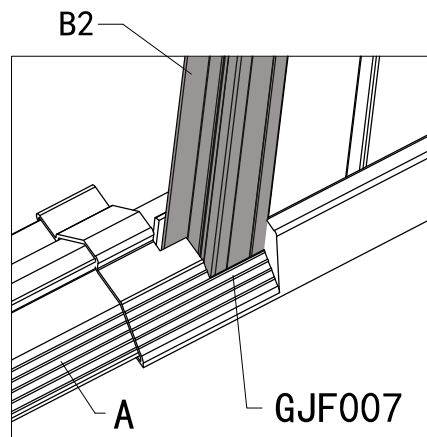
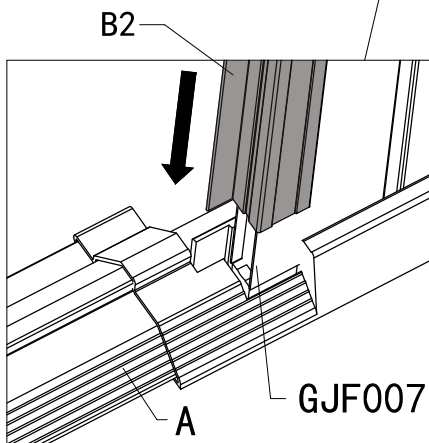
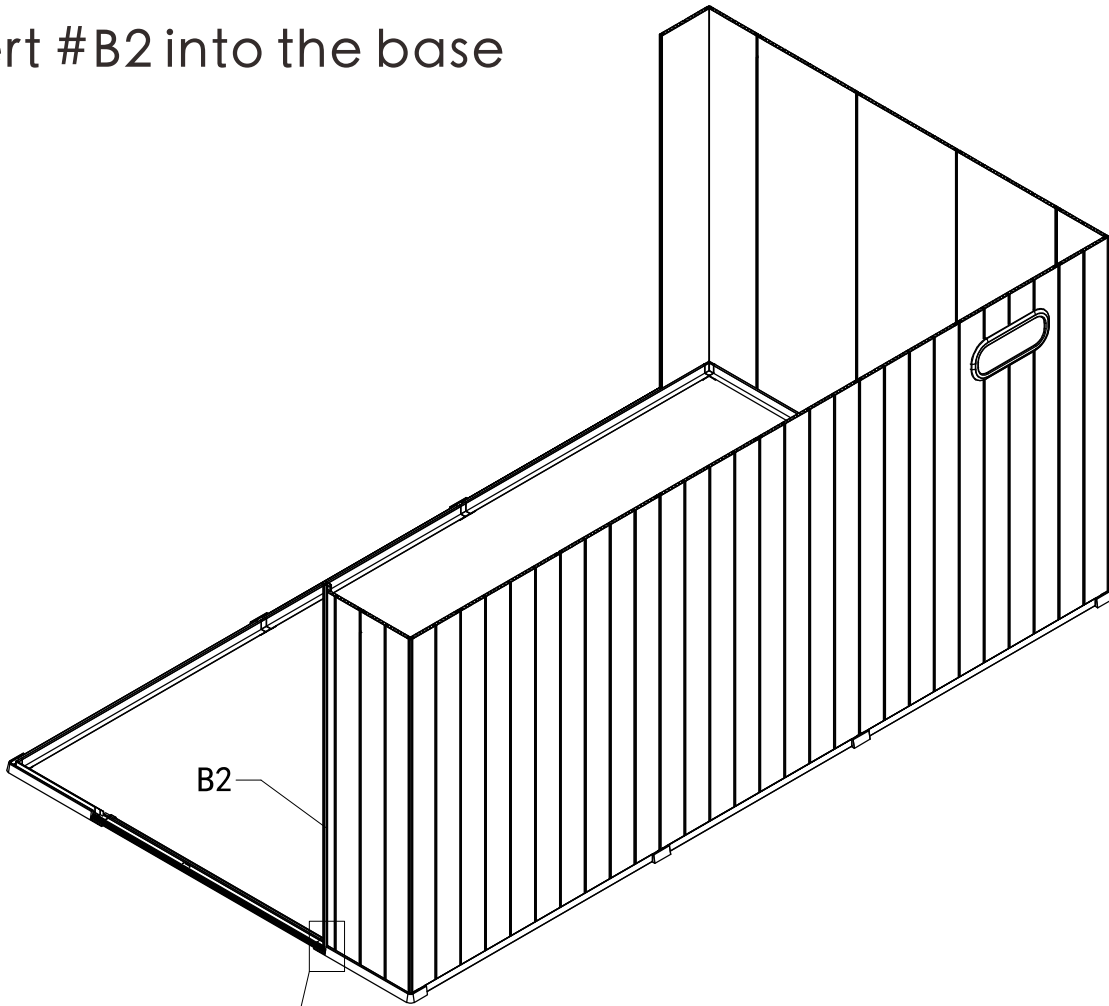

9# — x8

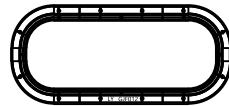
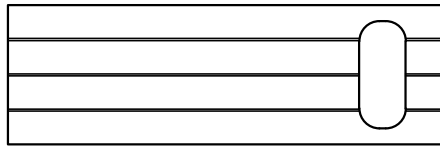

GJF012-x1

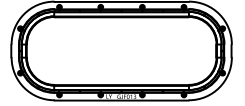

GJF013-x1

10# — x12



R-x1

B7x1

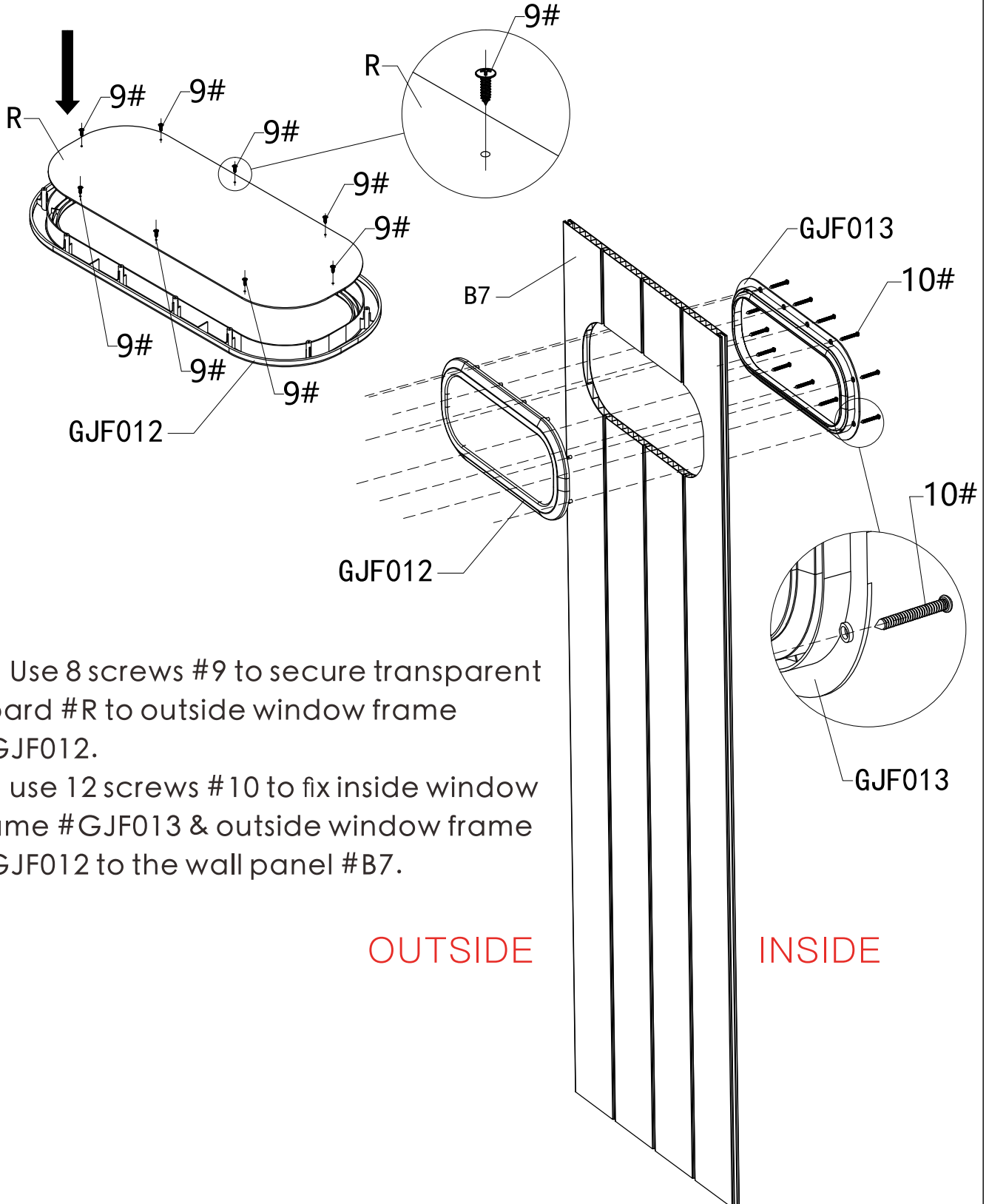

(1) Use 8 screws #9 to secure transparent board #R to outside window frame #GJF012.

(2) use 12 screws #10 to fix inside window frame #GJF013 & outside window frame #GJF012 to the wall panel #B7.

OUTSIDE

INSIDE

B5x1

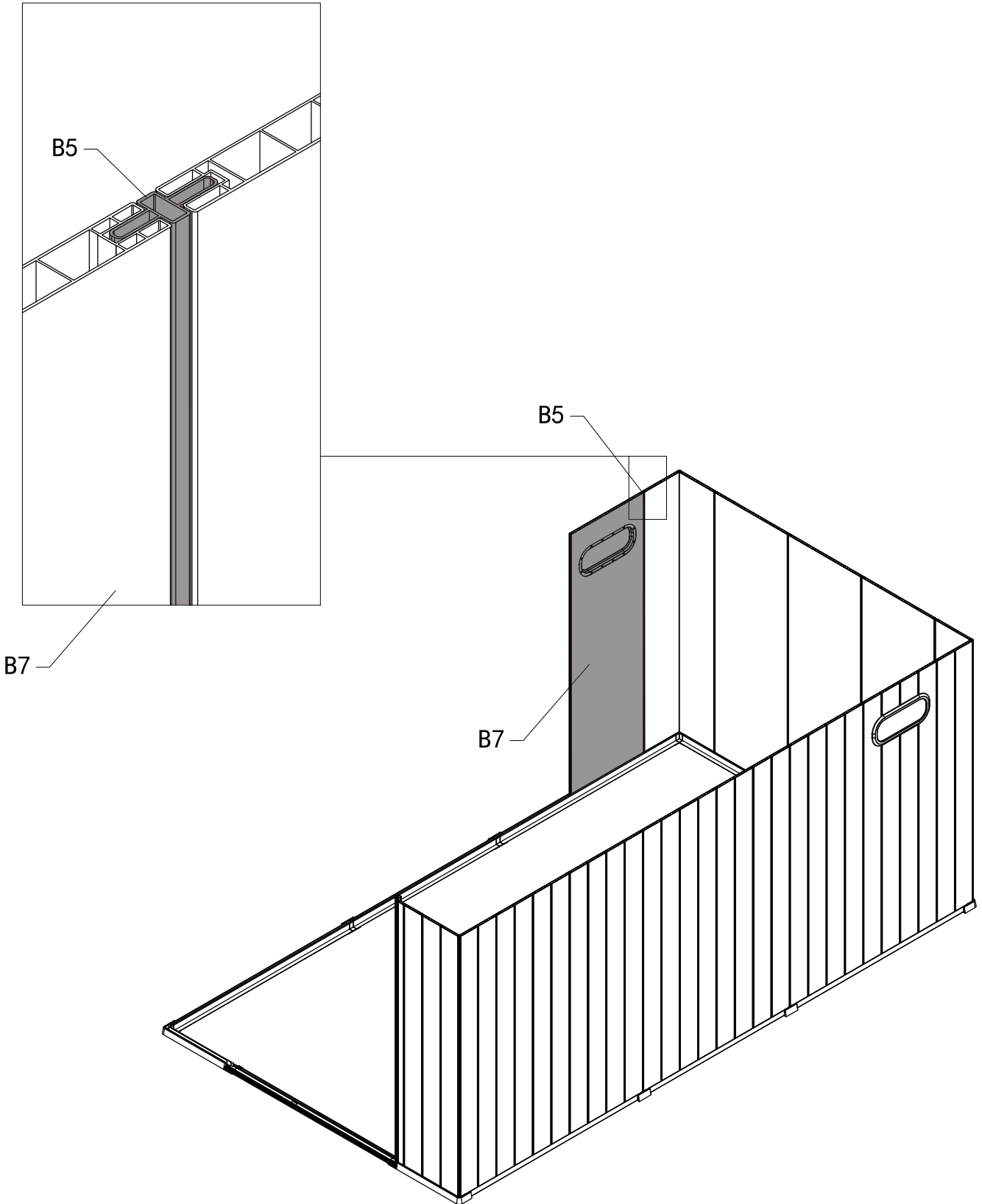

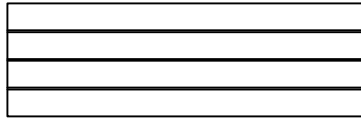

B3-x5



B5x5

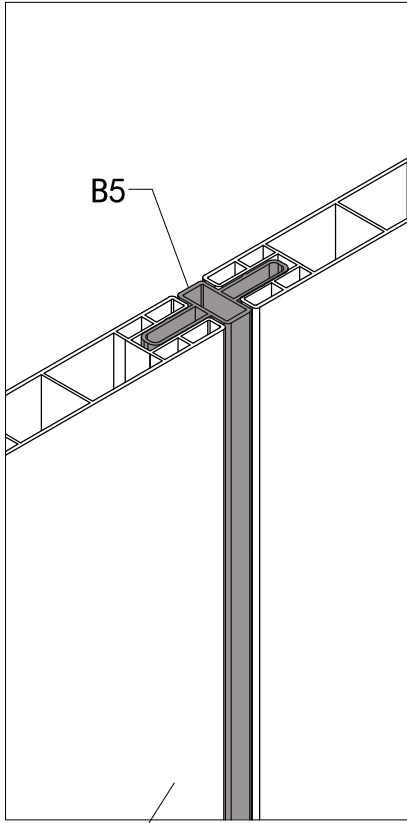

B5

B3

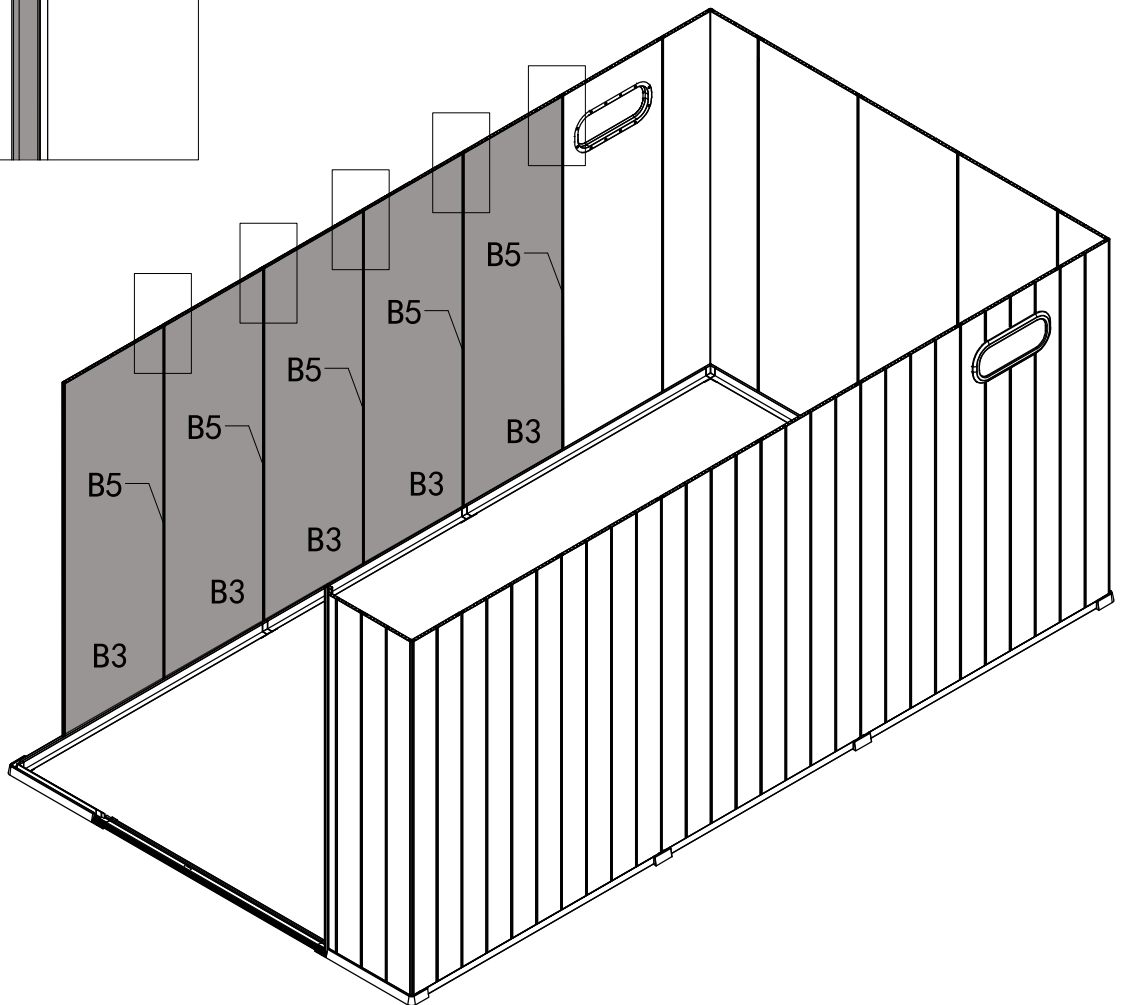

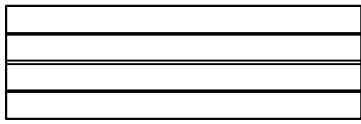

B - x1

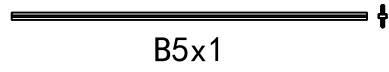

B5x1

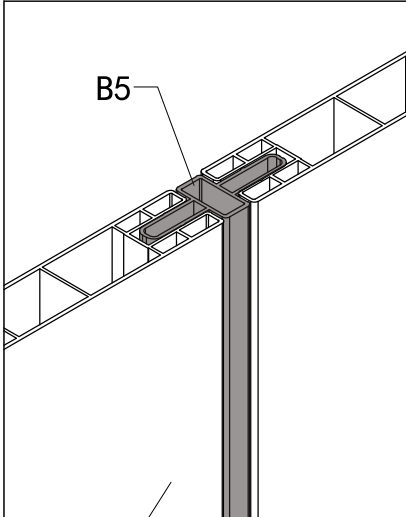

B5

B

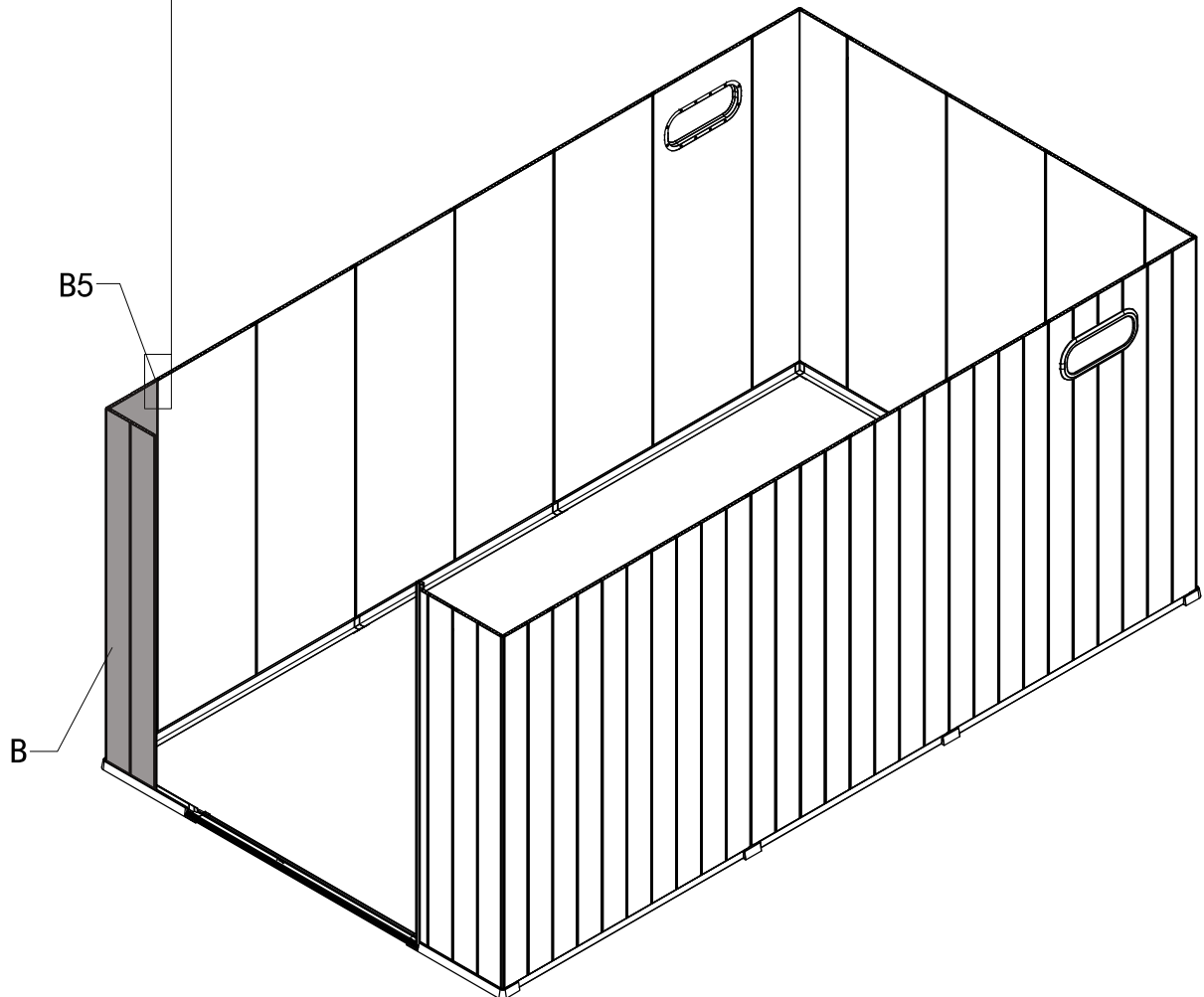

B5

B

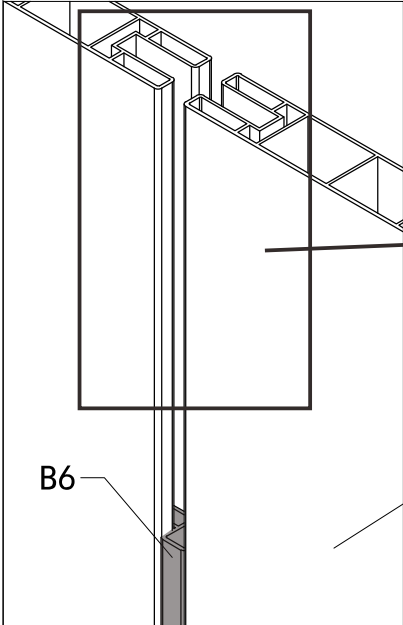
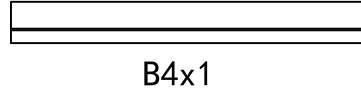
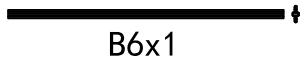

For subsequent installation needs, there is a notch in the joint of the two wall panels.

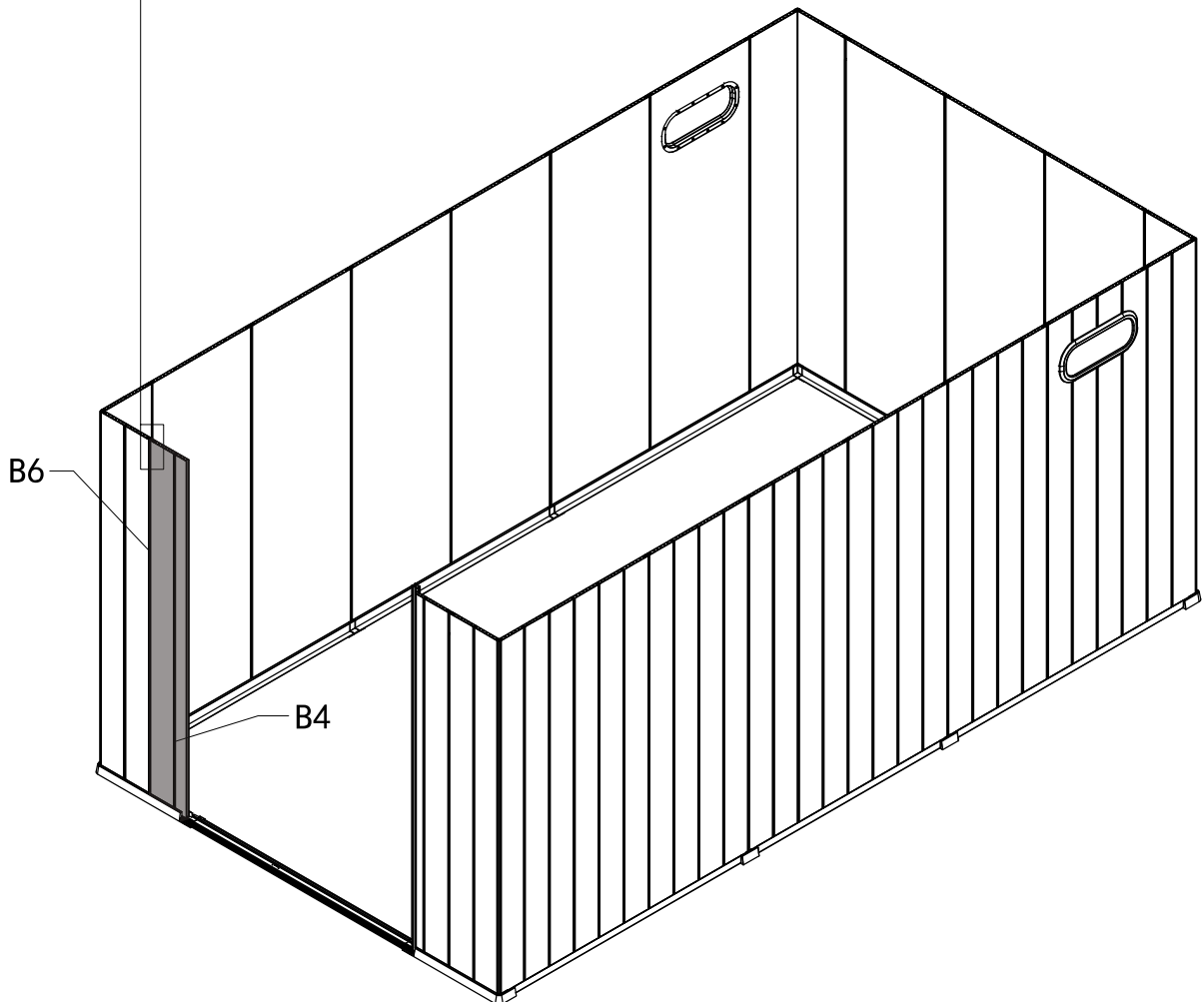



B1-x1

Insert #B1 into the base

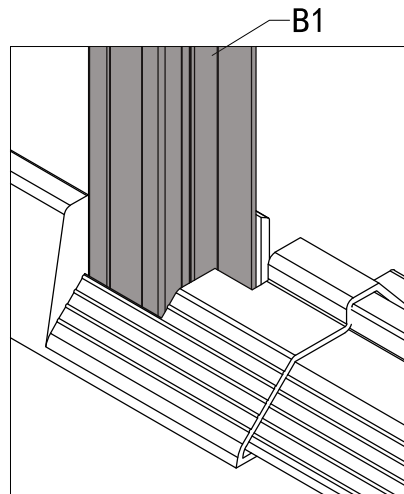
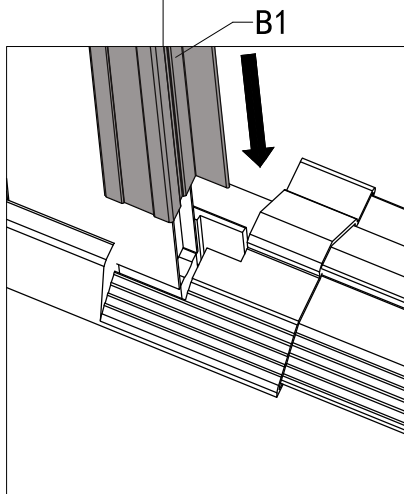
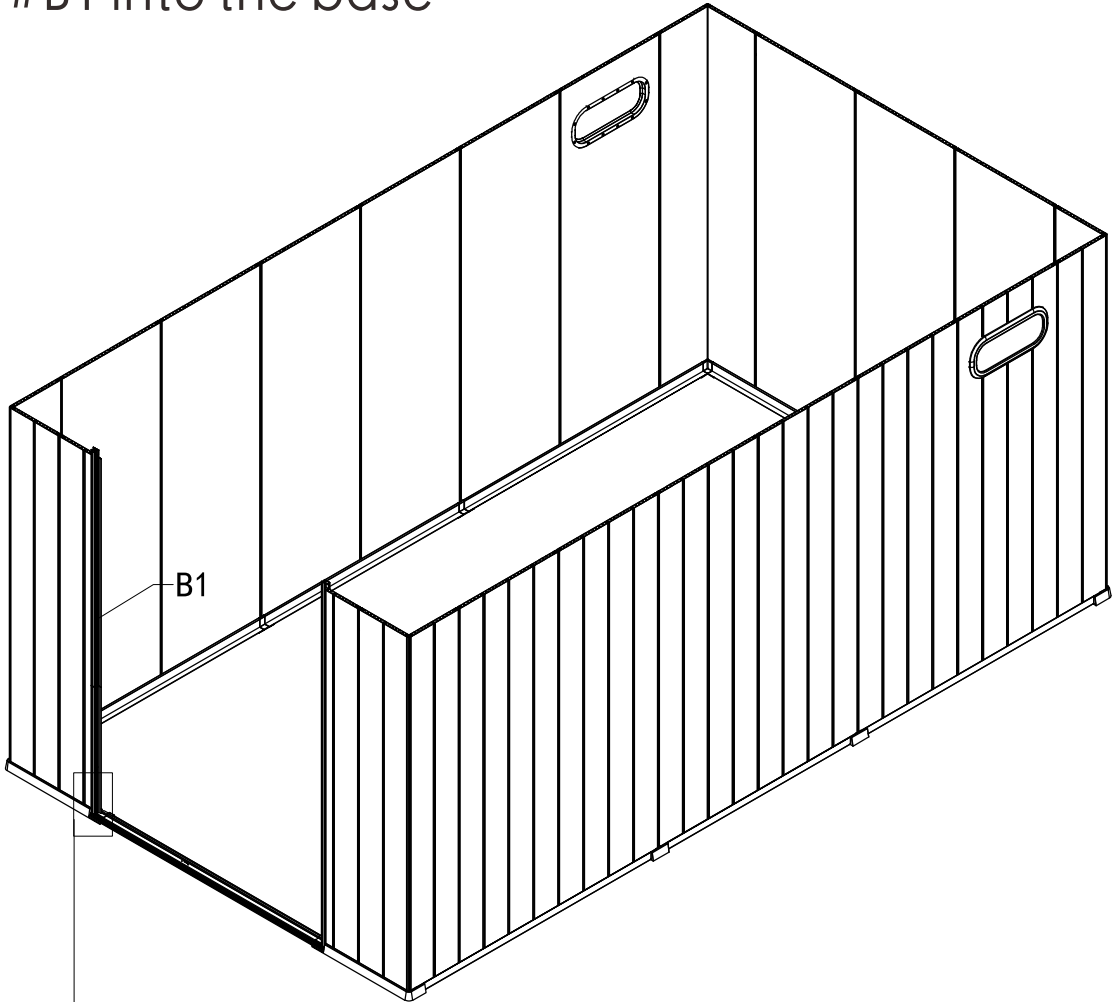

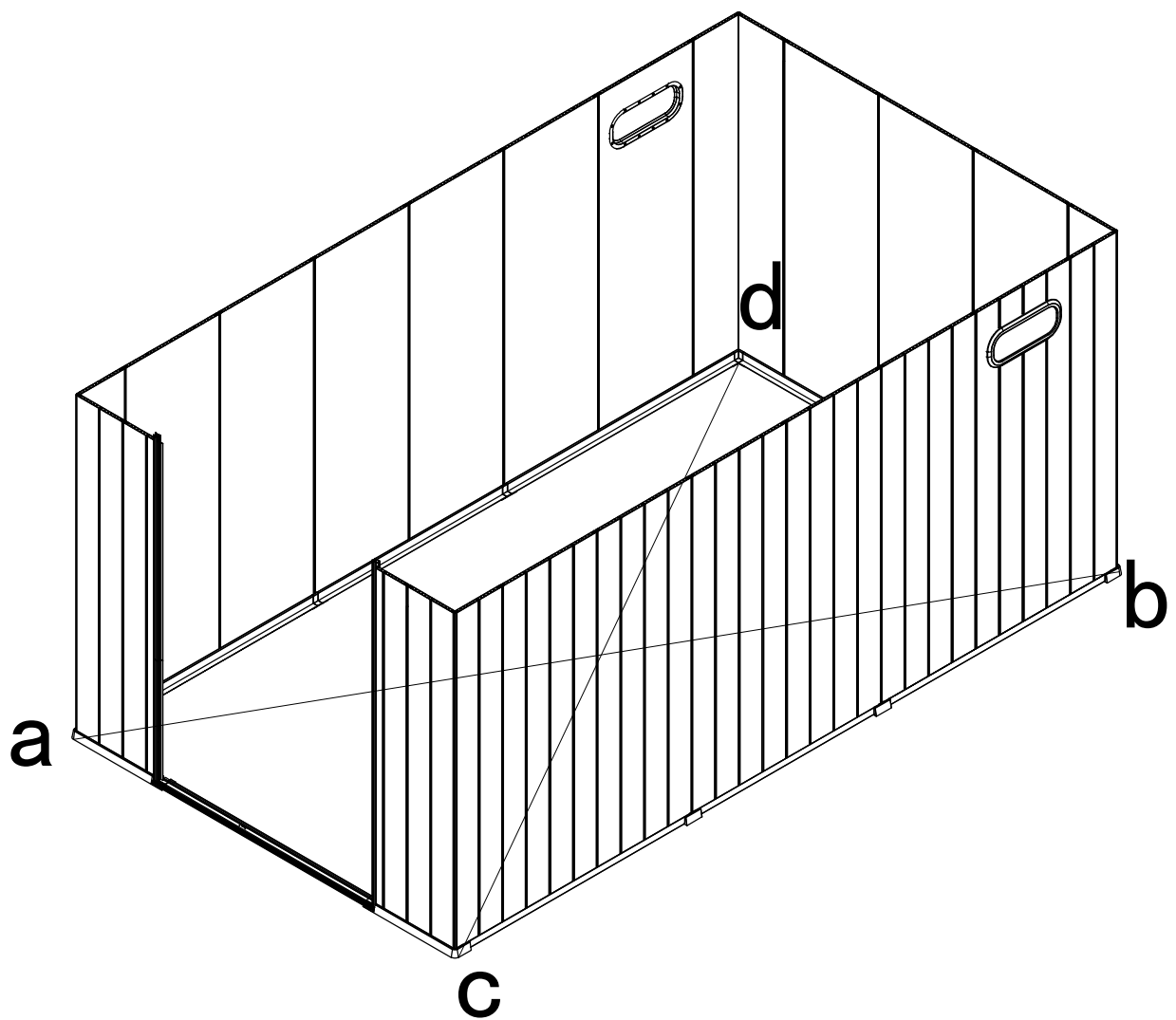
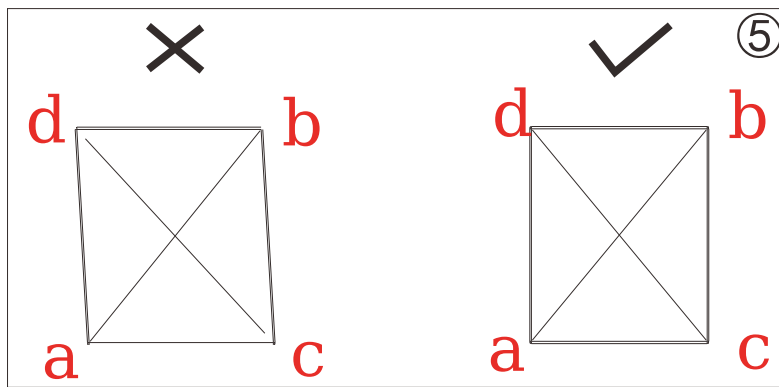

Before installing the screws, adjust the angle of the base and the wall to a rectangle: diagonal  $a-b=c-d$ .

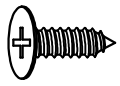

5# - x22



Ø3 Q3 - x1

Use screws 5# to secure the base frame with wall panel.

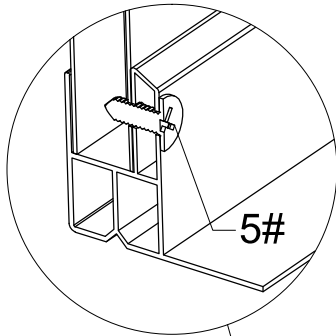

5#

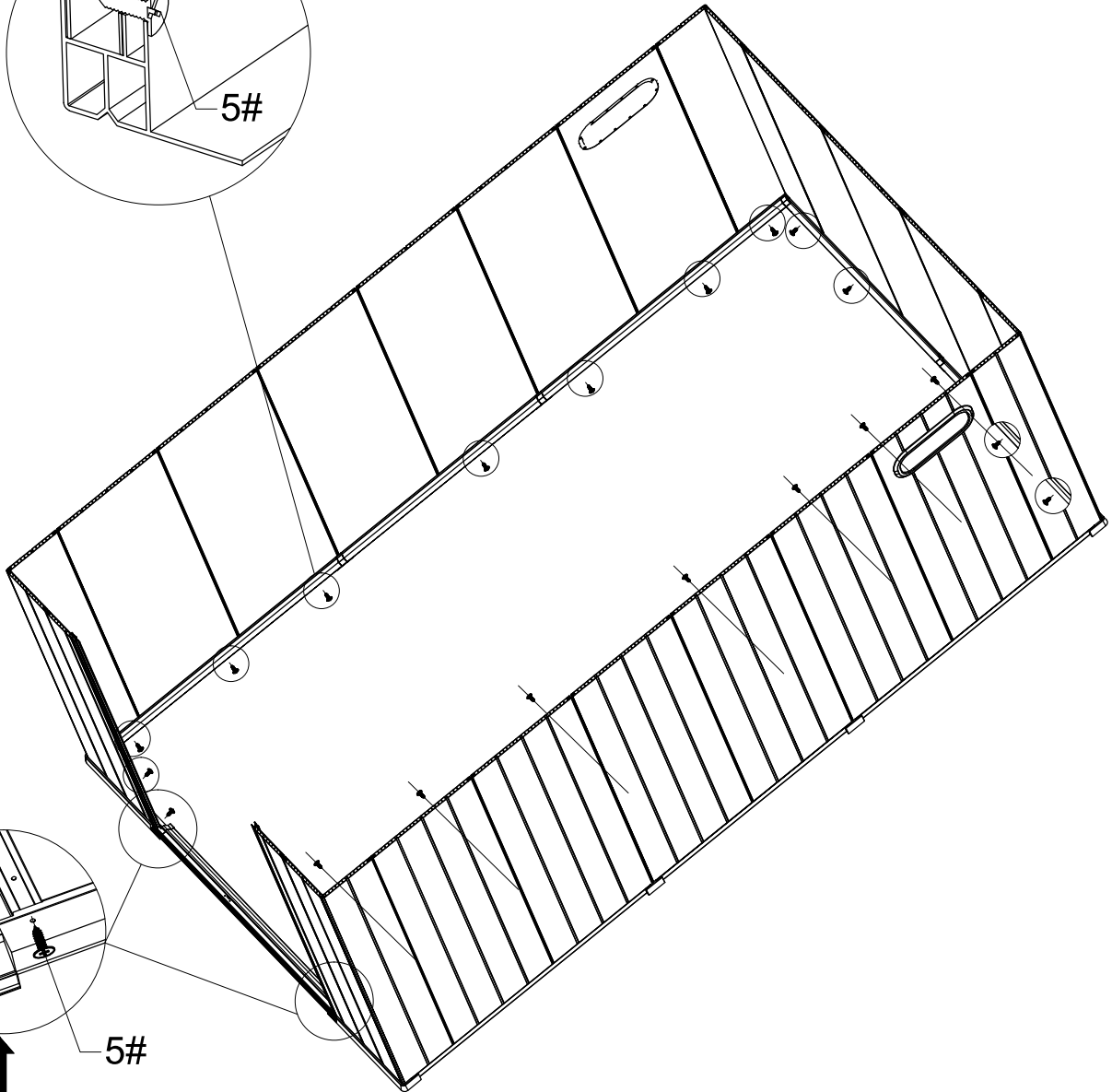

5#

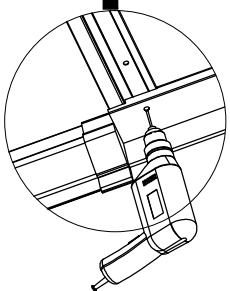
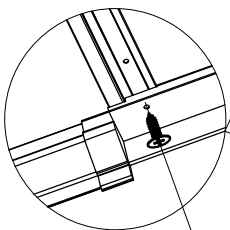

Note: These TWO positions need to be drilled in the base (3mm diameter drill bit), and then install screws 5# to the wall panel.

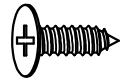

5# - x56

Use 56 screws 5# to secure the wall panels to the connecting rods #B5/B6.

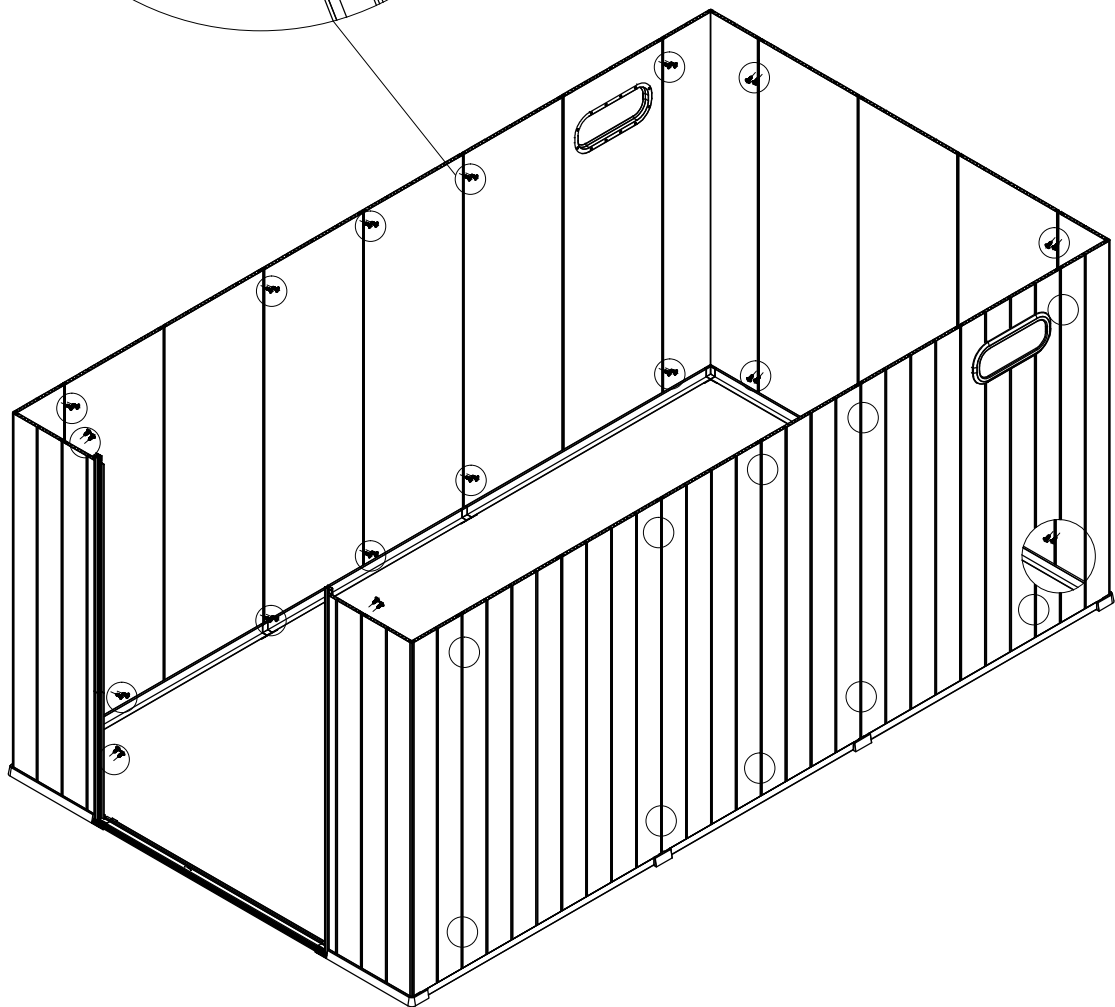
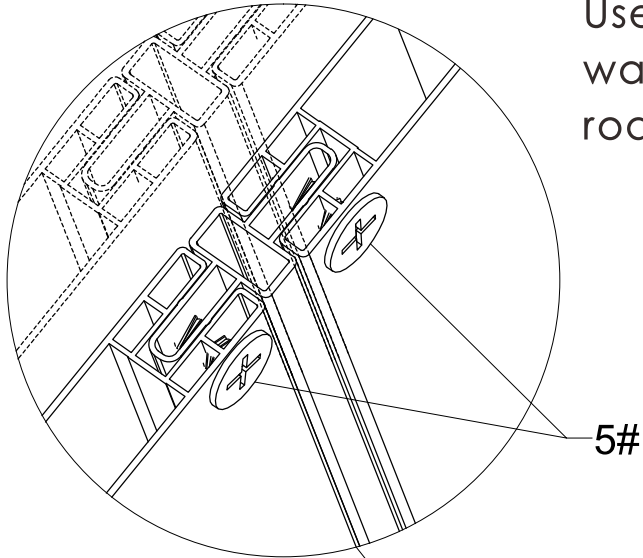

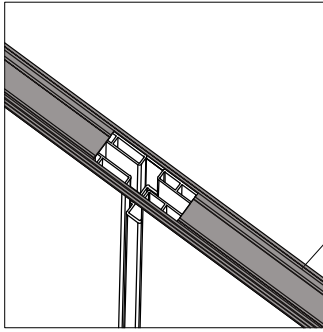
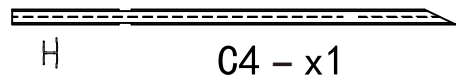
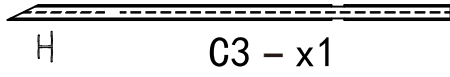

C4

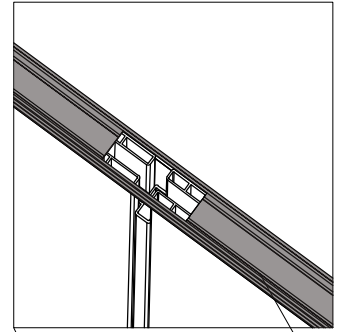
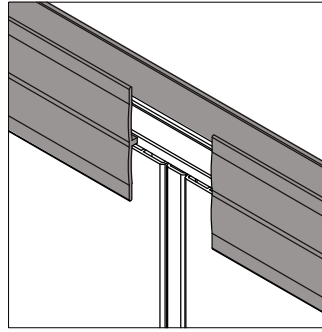

C3

Make sure that the two sides of this notch are symmetrical.

BACK SIDE

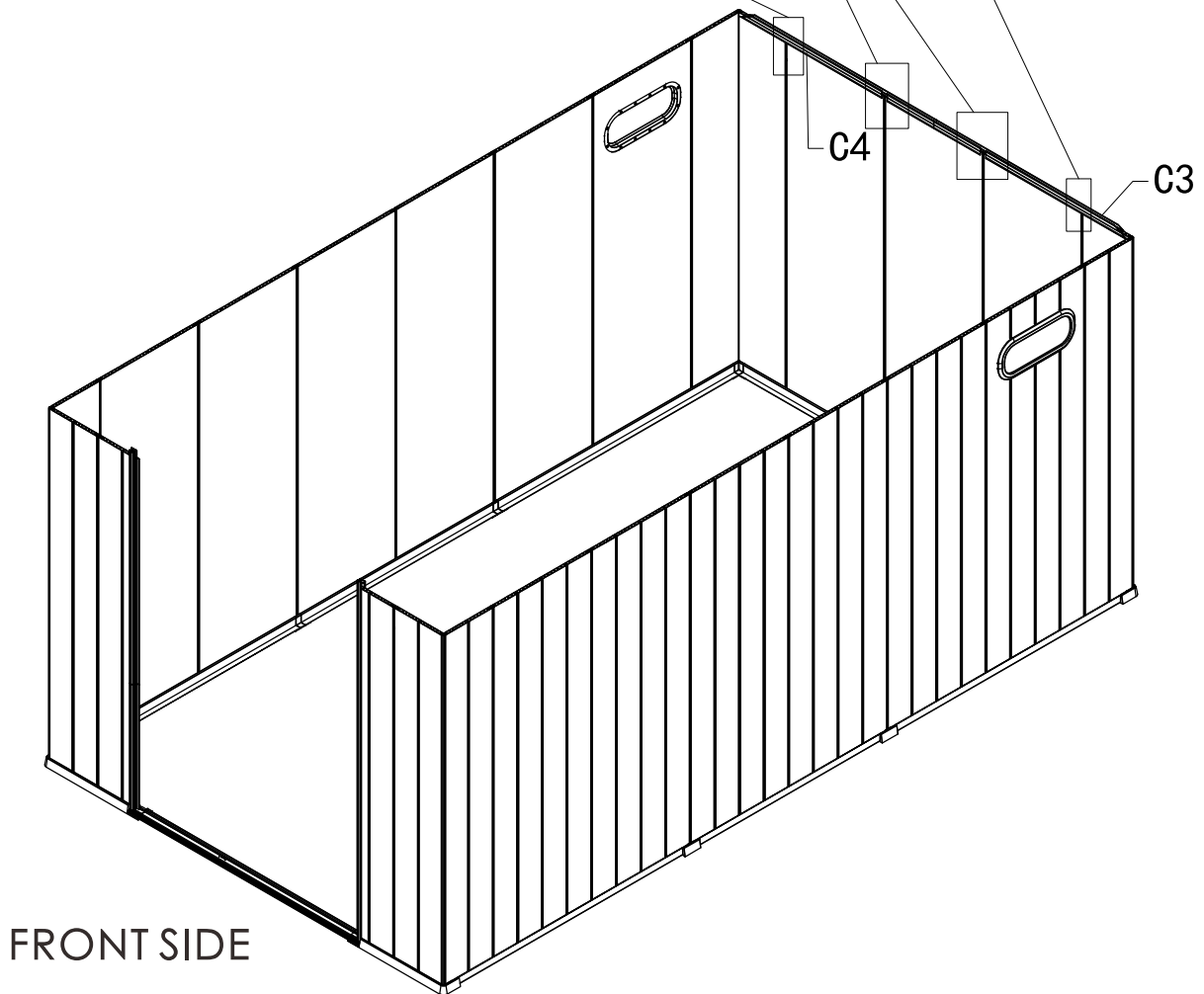

FRONT SIDE

C4

C3

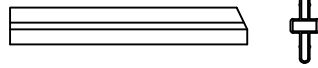

D6—x1

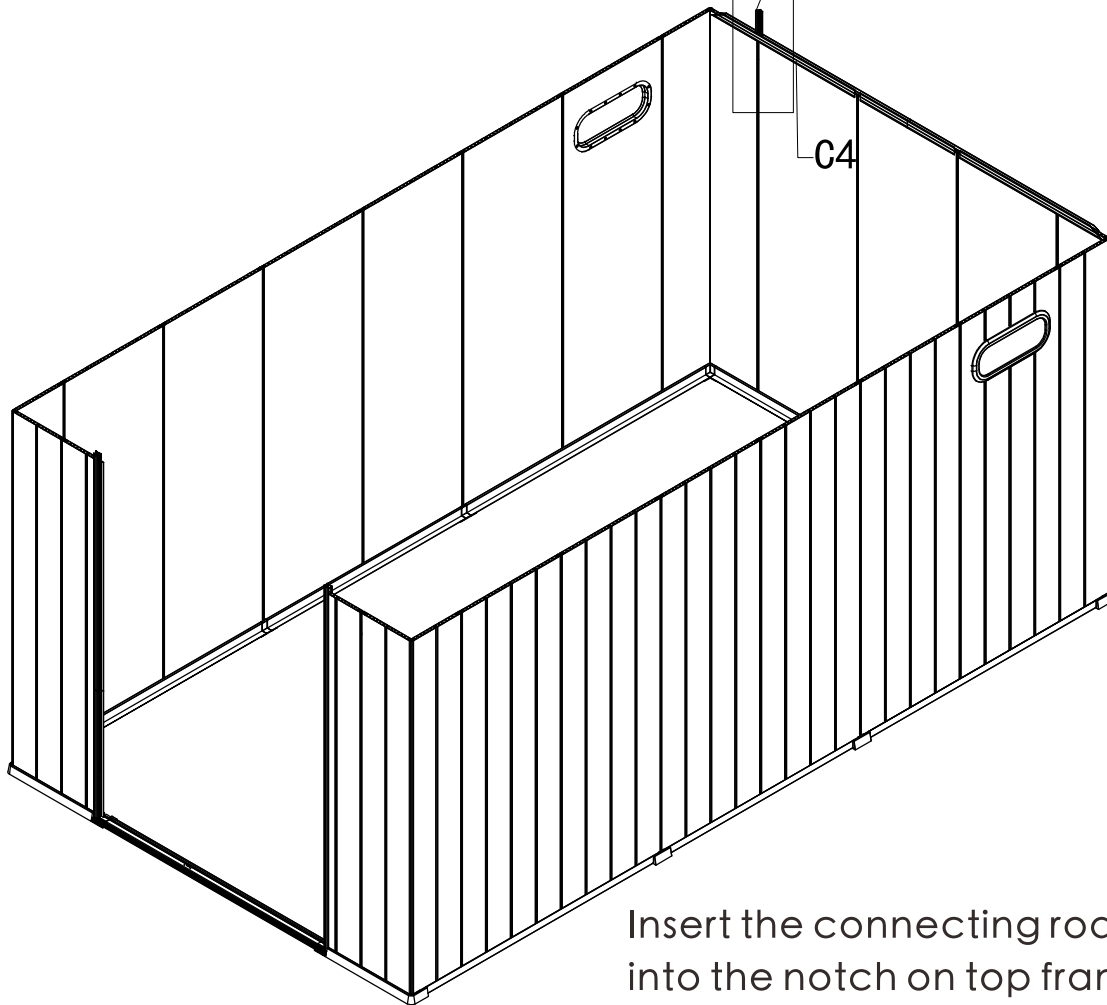
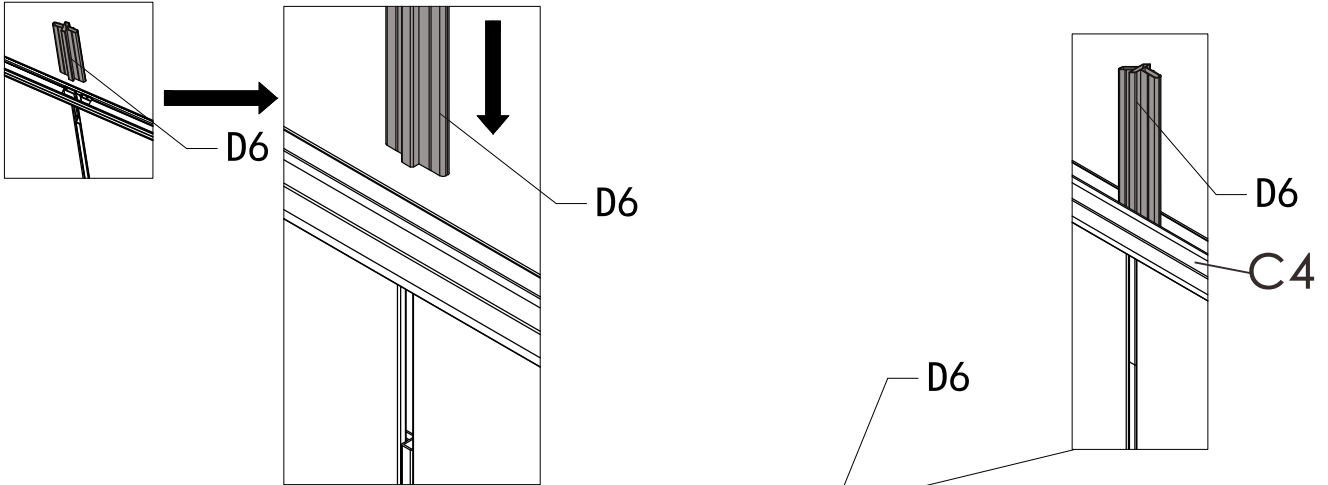

Insert the connecting rod #D6 into the notch on top frame #C4.

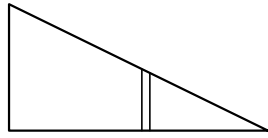

D4—x1

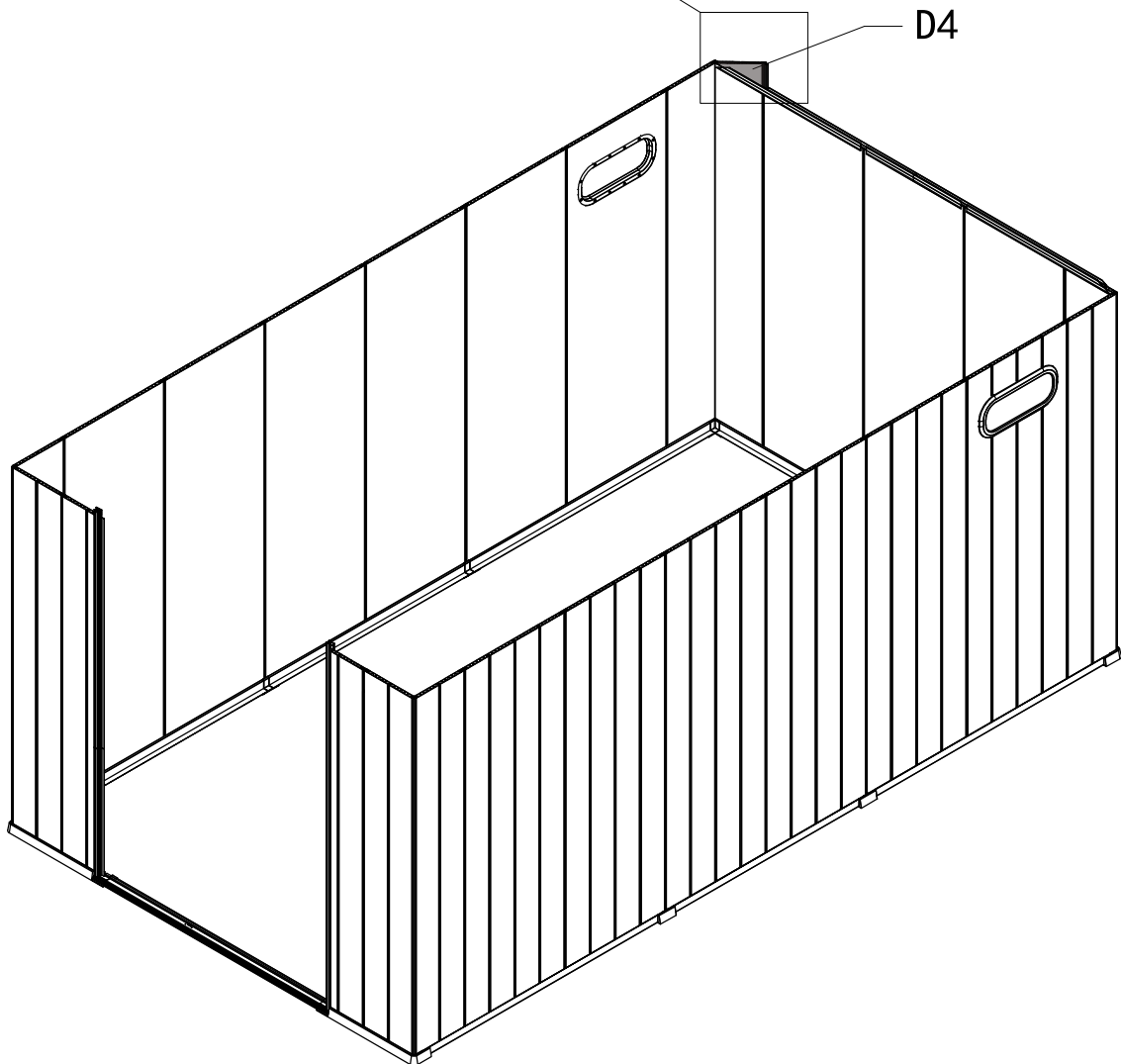
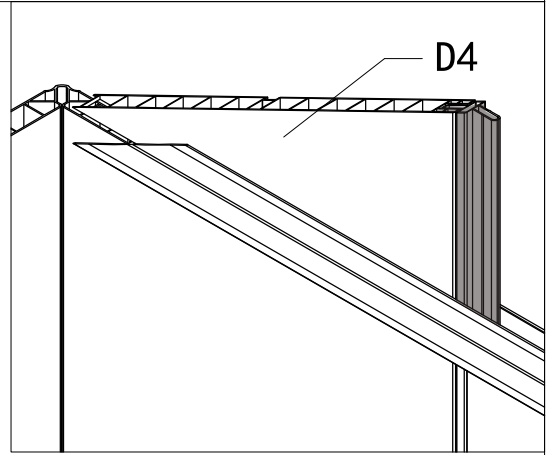
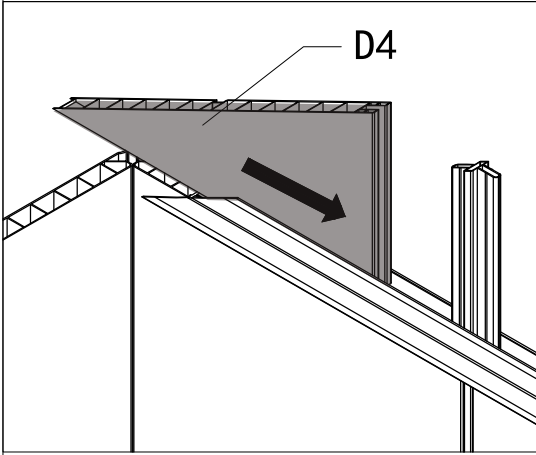

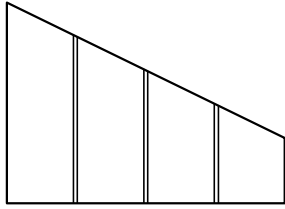

D2 —x1

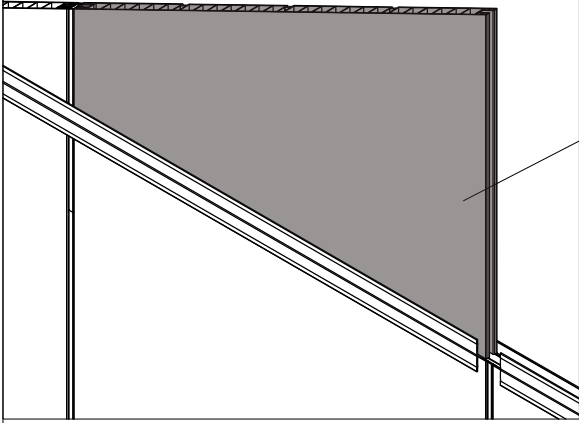

D2

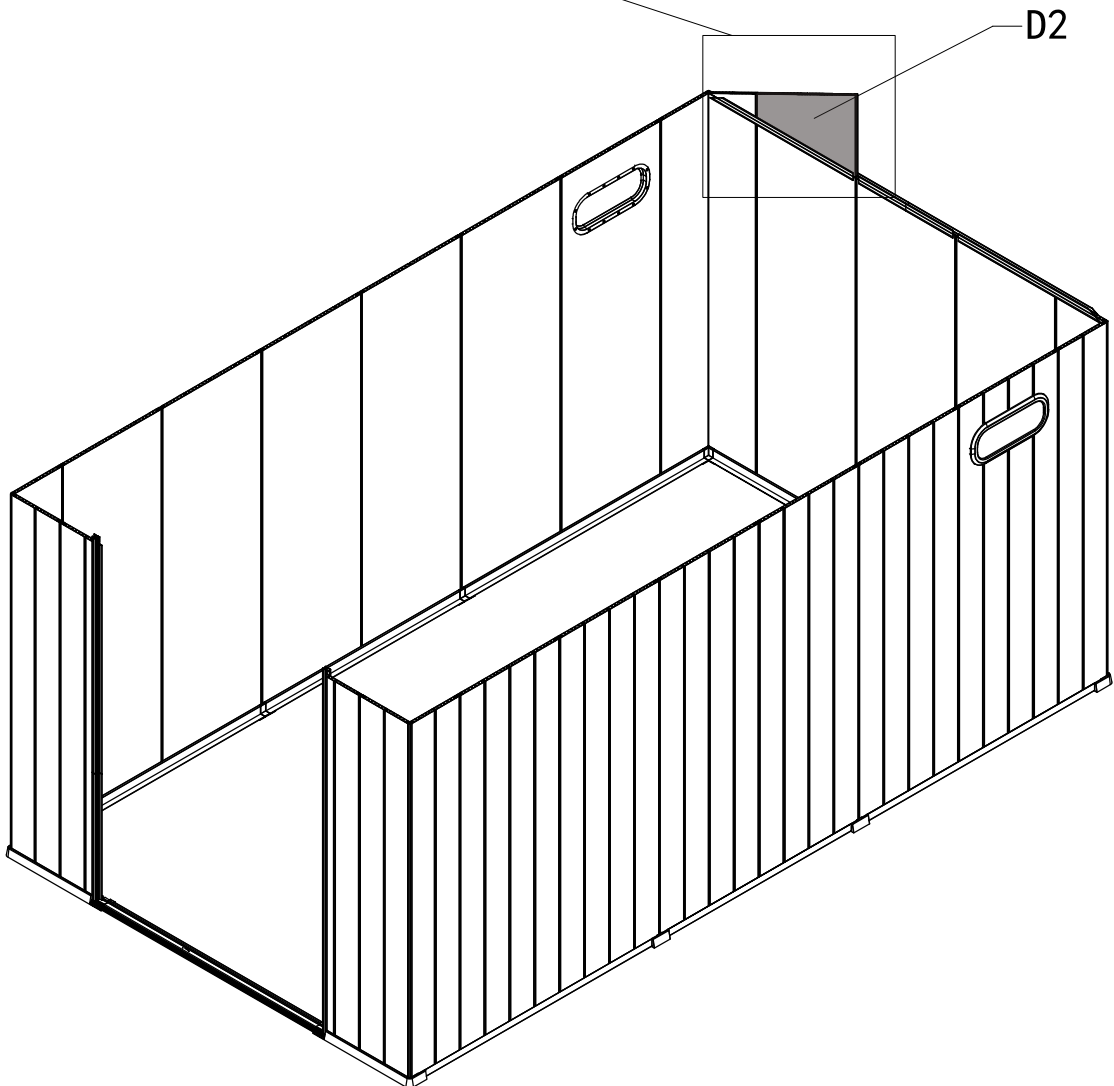

D2

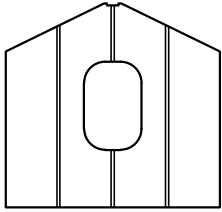

D-x1

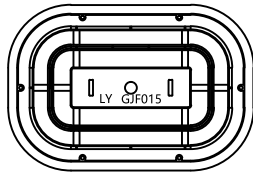

GJF015-x1

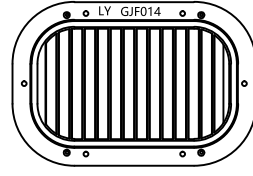

GJF014-x1



8# - x6

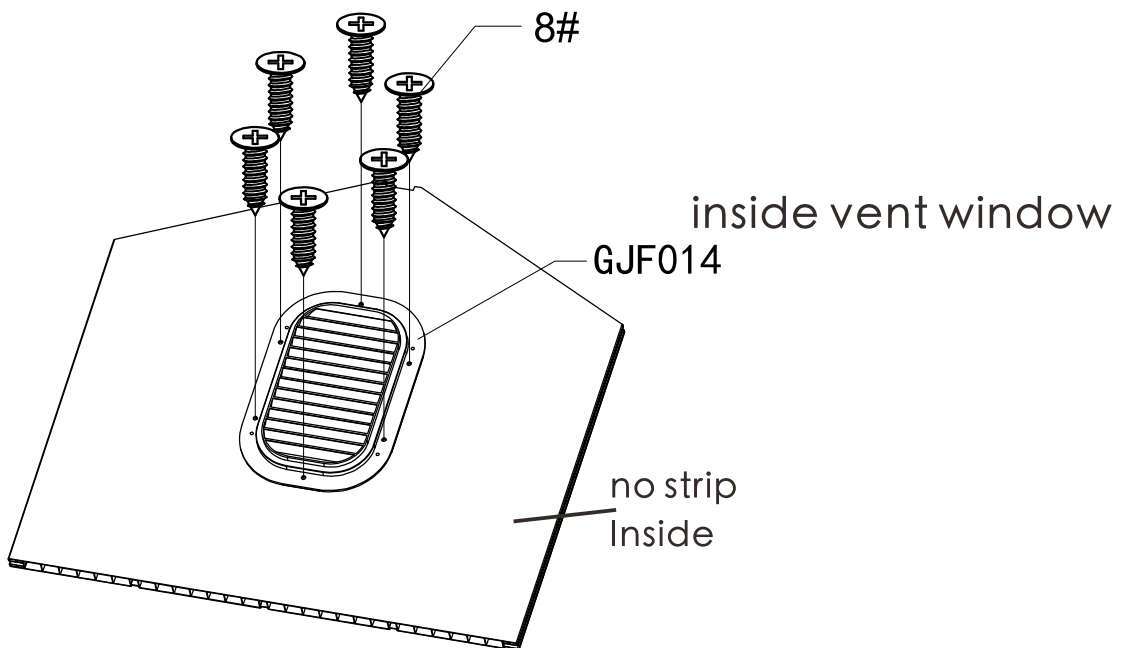
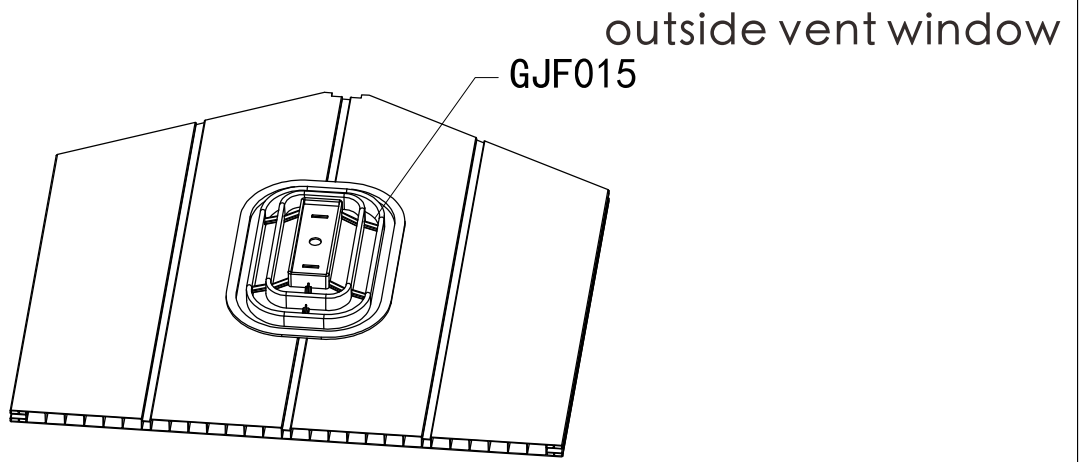
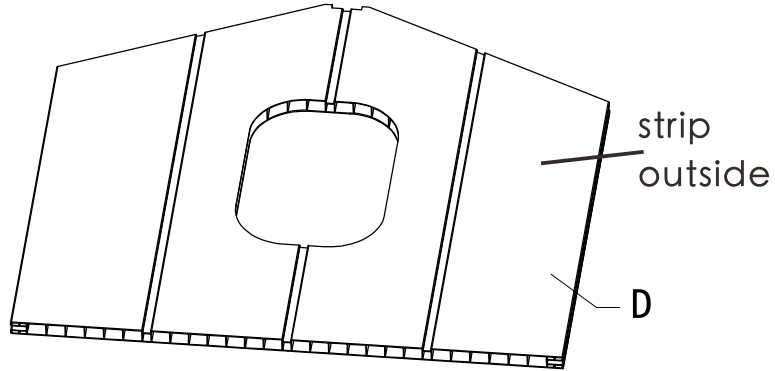

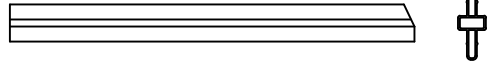

D5—x1

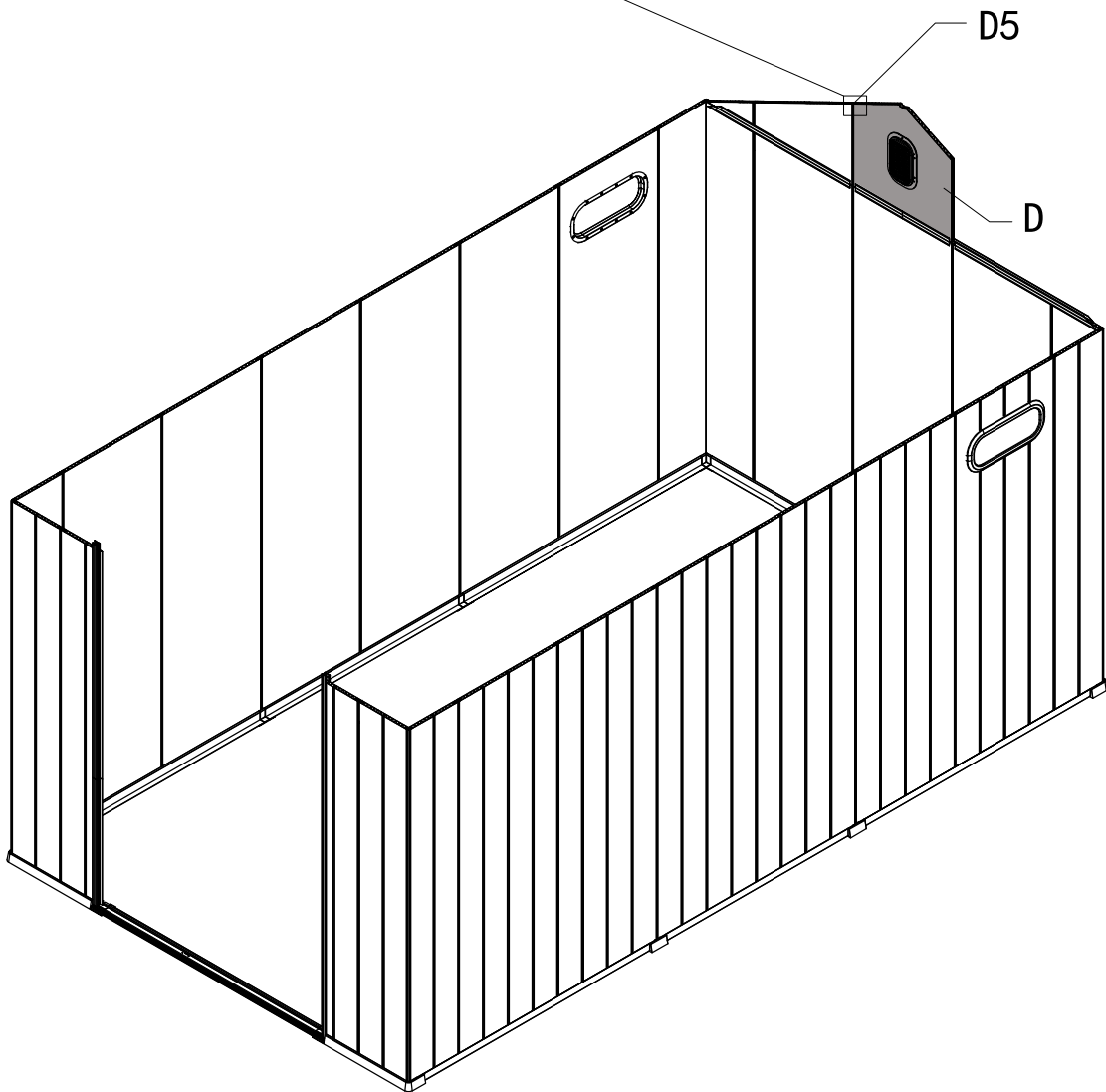
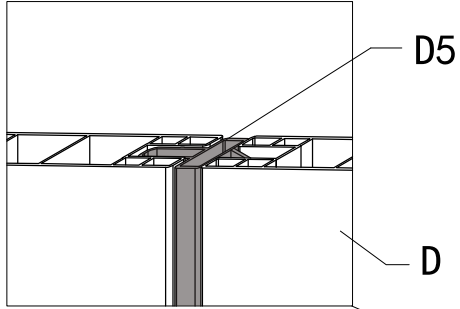

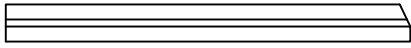

D5—x1

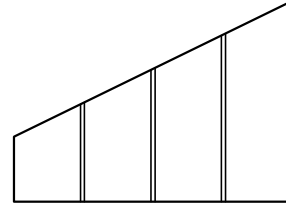

D1—x1

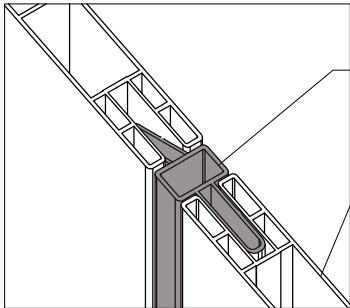

D5

D1

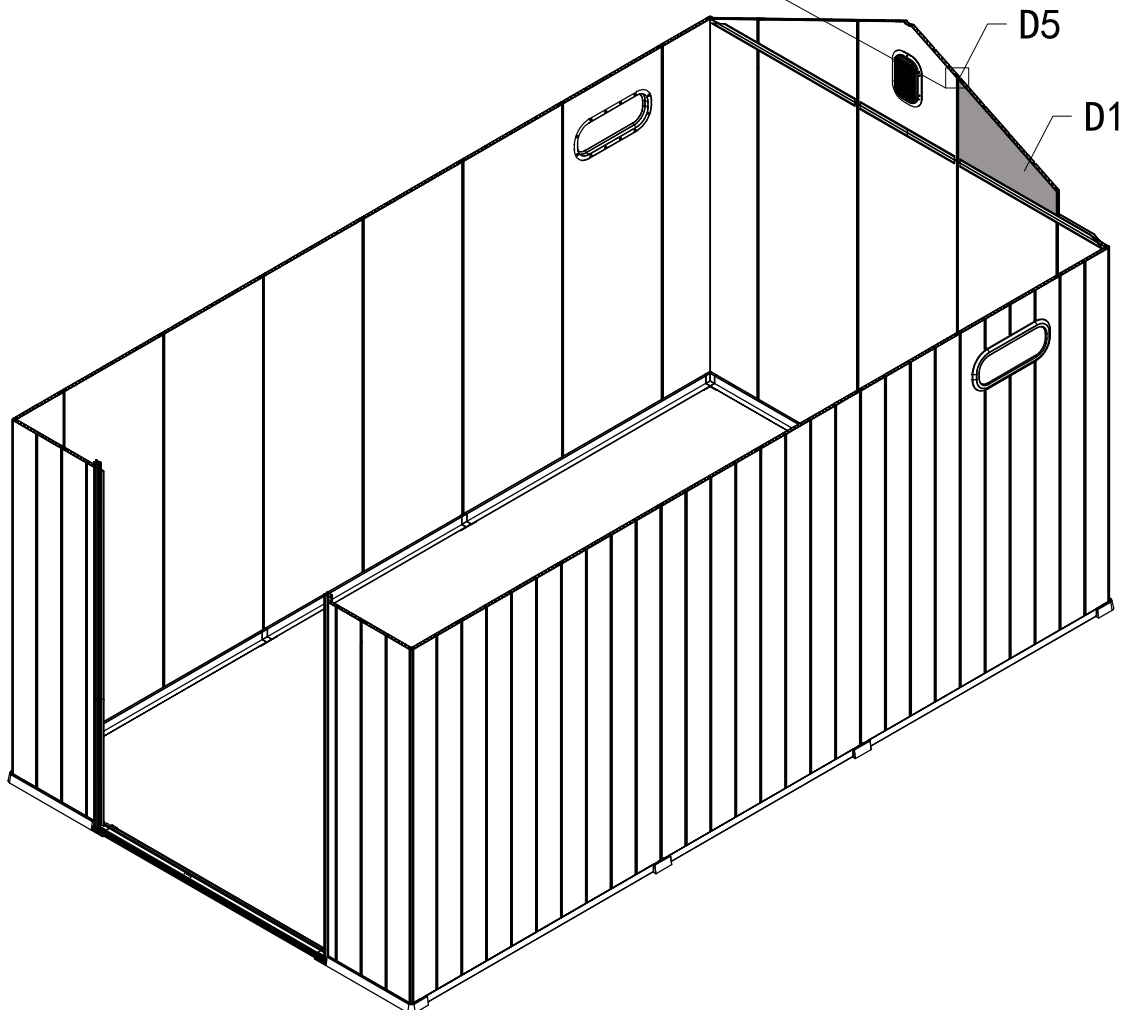

D5

D1

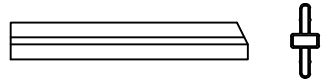

D6 - x1

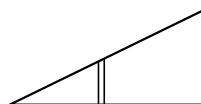

D3 - x1

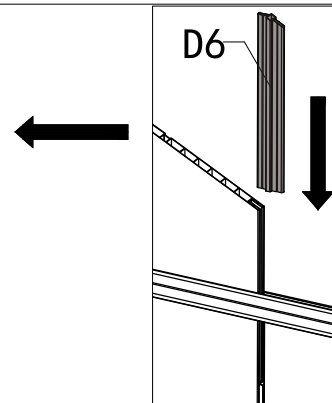
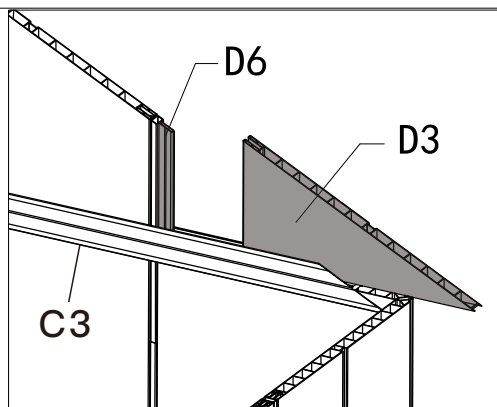

Insert the connecting rod #D6 into the notch on top frame #C3.

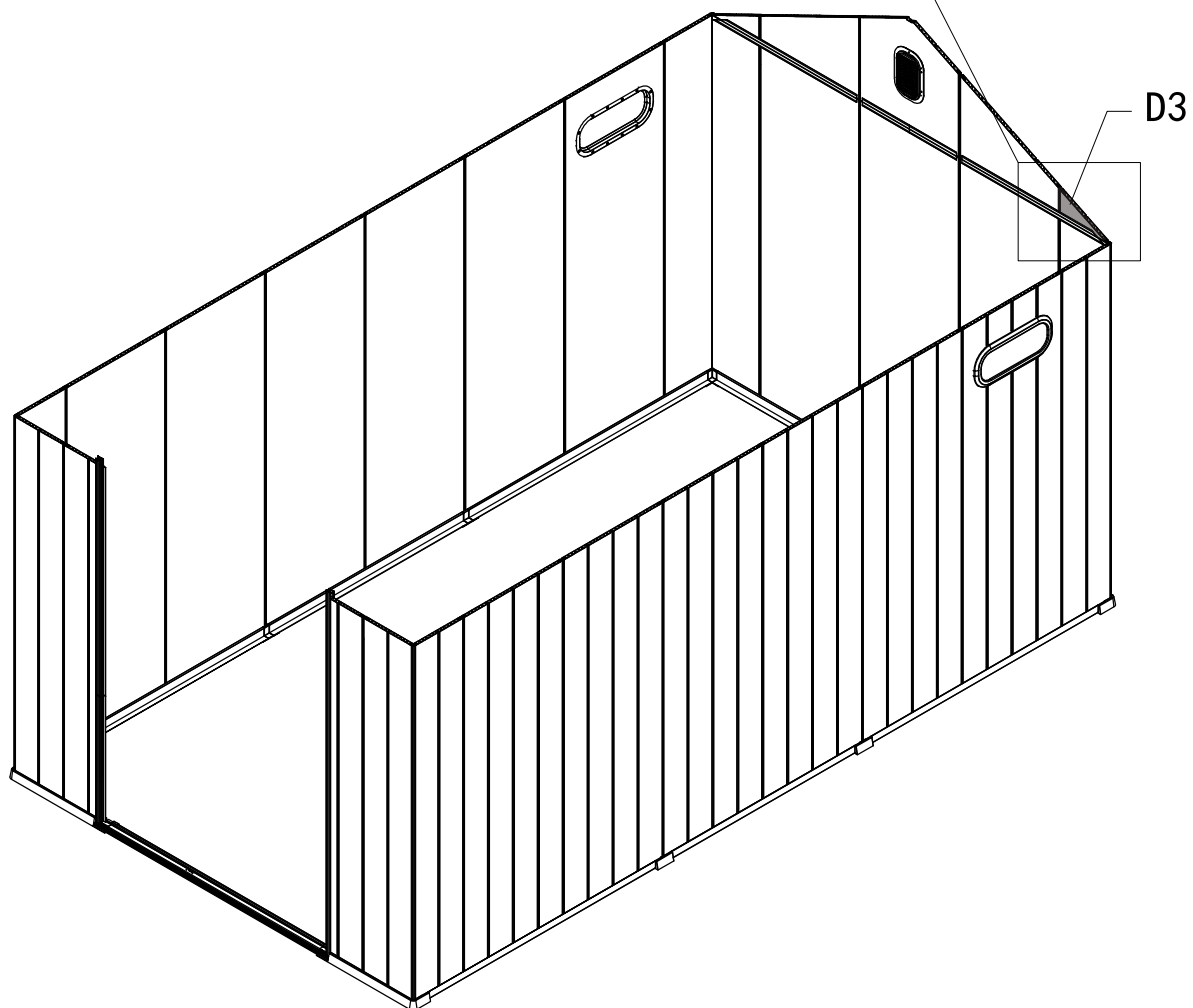



H C1 - x1



H C2 - x1



6# - x16

Use 16 screws 6# to secure top frame #C4 & C3 to the BACK wall panels.

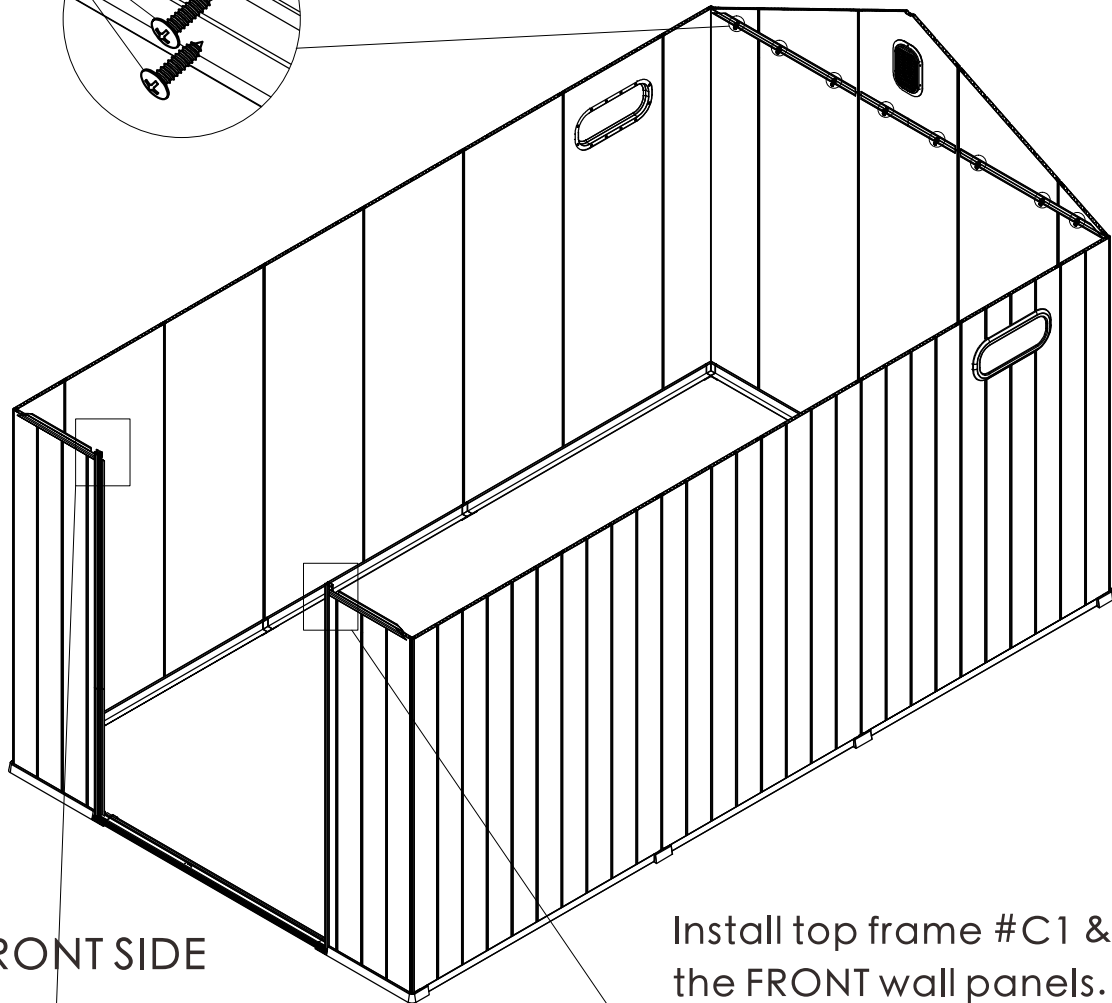
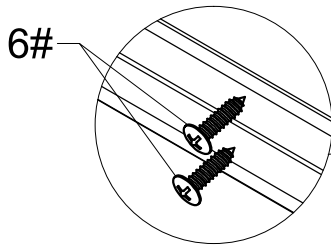

FRONT SIDE

Install top frame #C1 & C2 to the FRONT wall panels.

C1

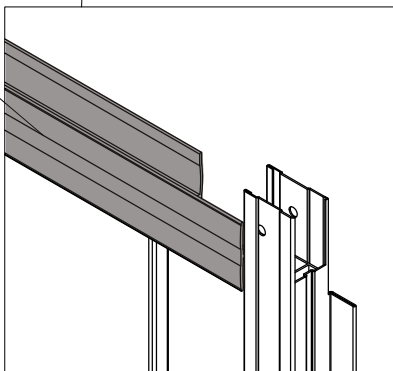

C2

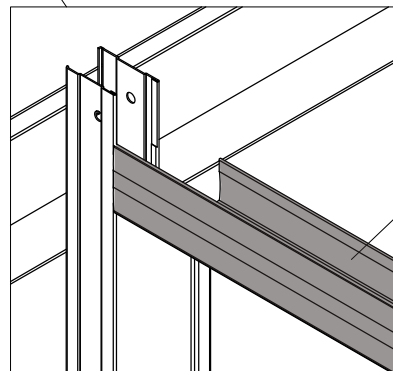

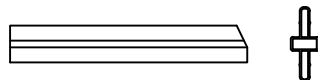

D6 - x1

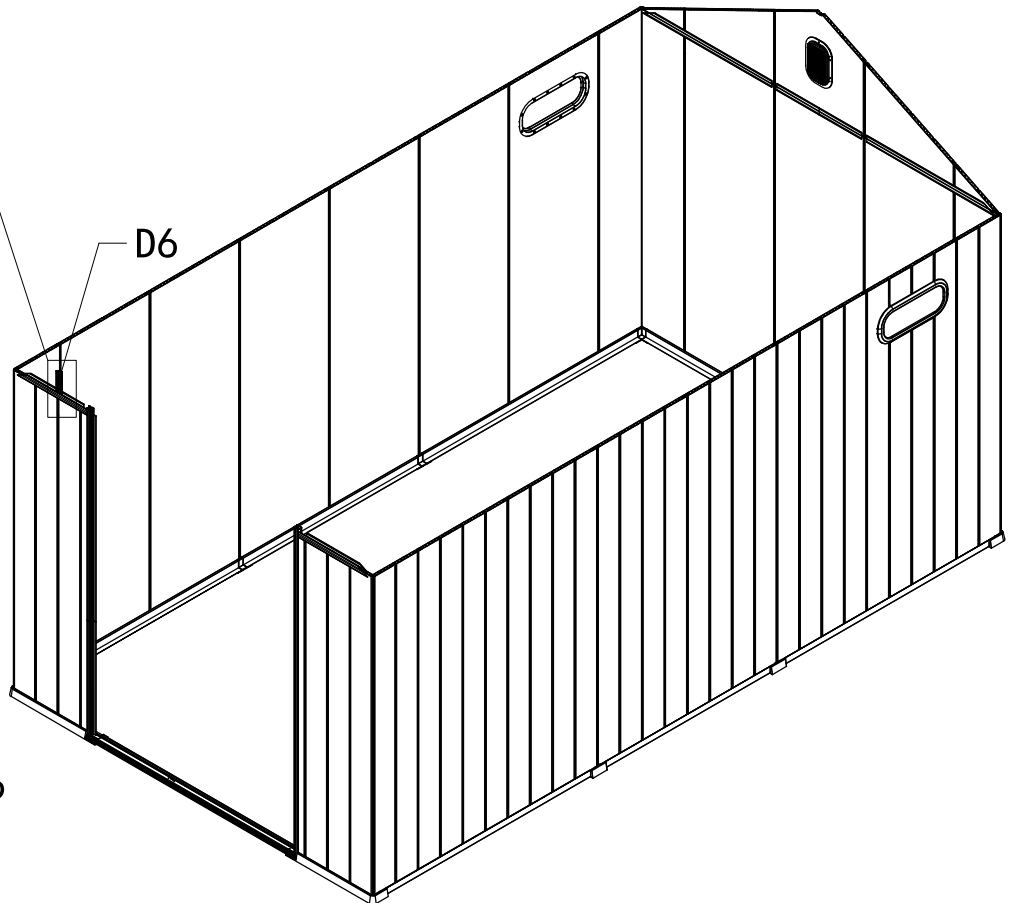
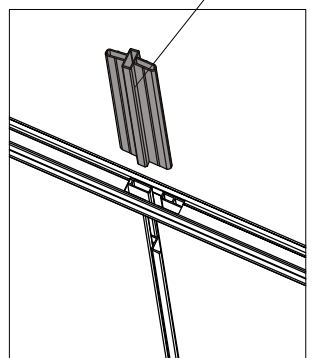
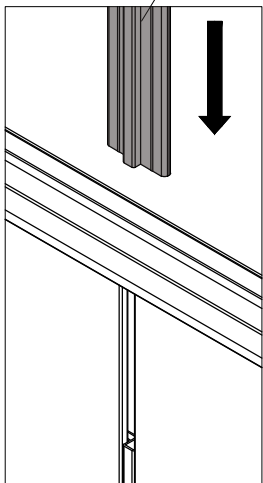
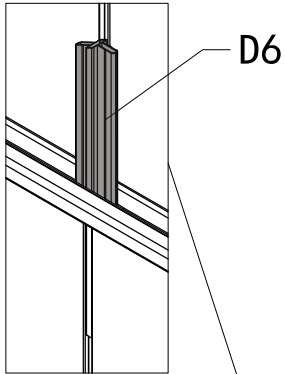

Insert the connecting rod #D6 into the notch on top frame #C1.

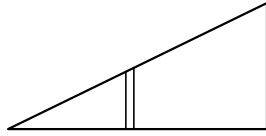

D3 - x1

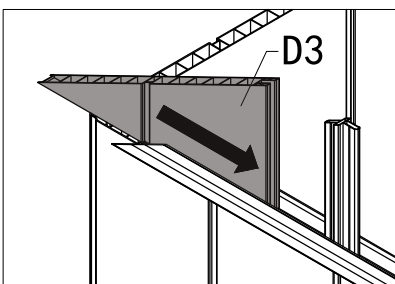
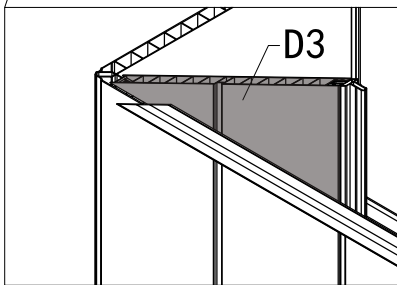
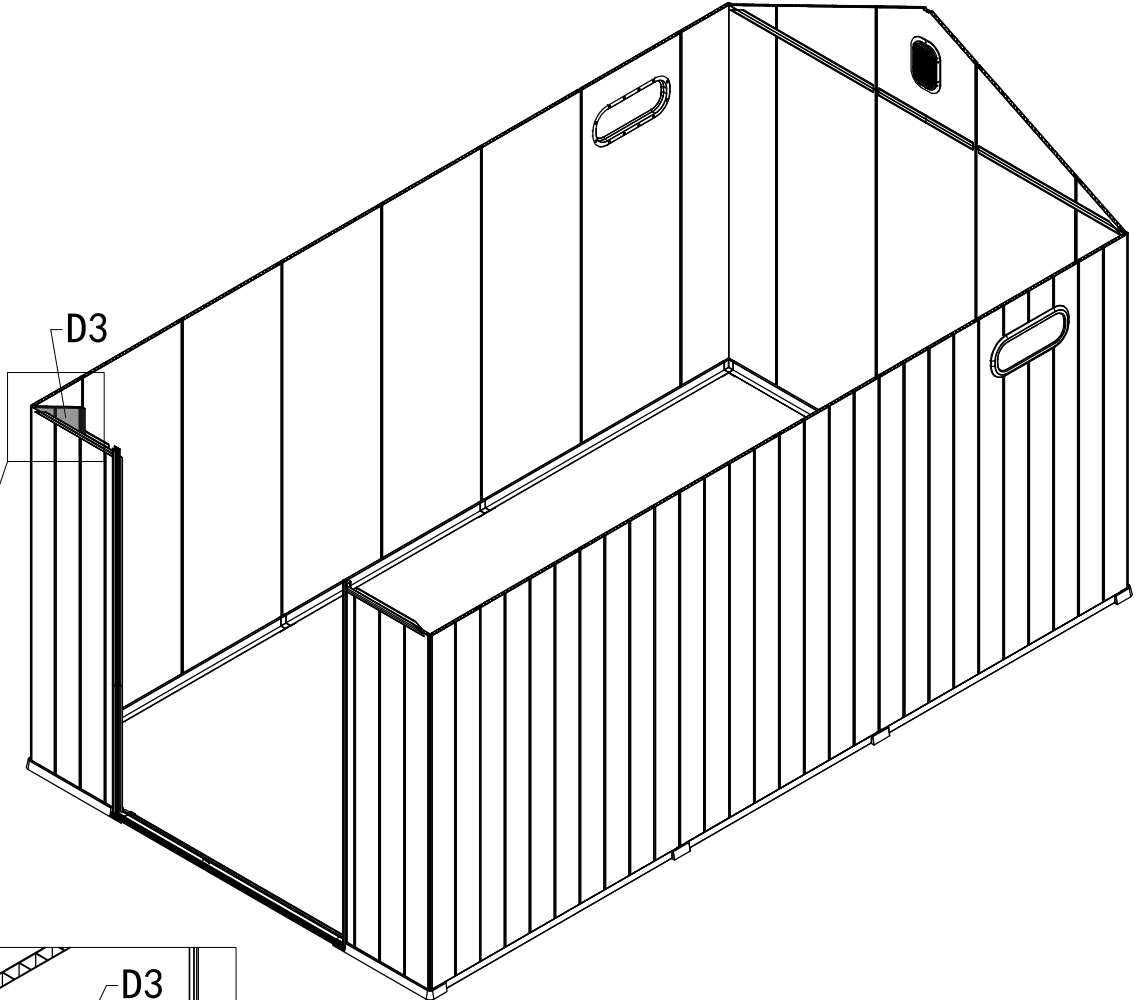

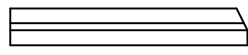

D6 - x1

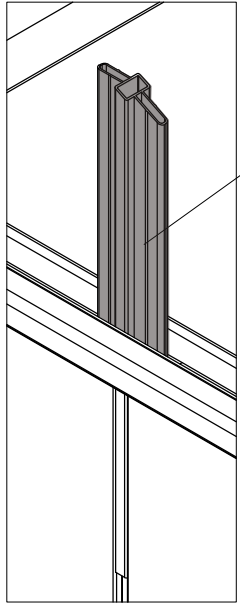

D6

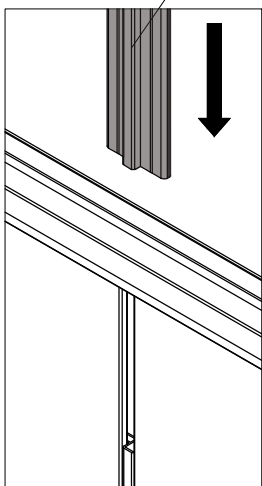

D6

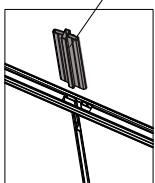

D6

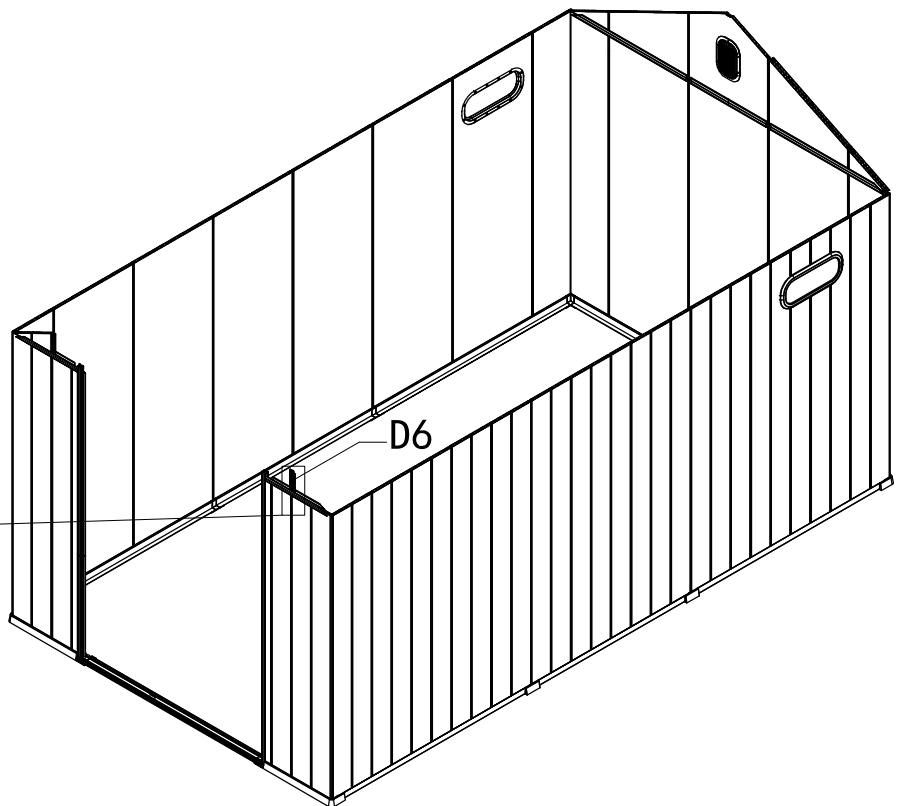

Insert the connecting rod #D6 into the notch on top frame #C2.

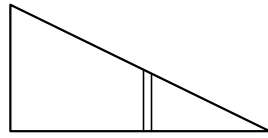

D4 - x1

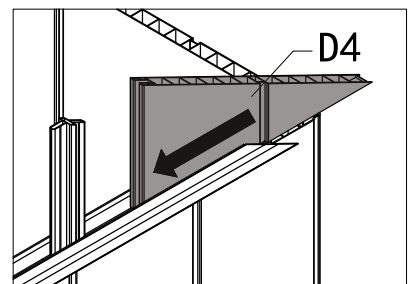
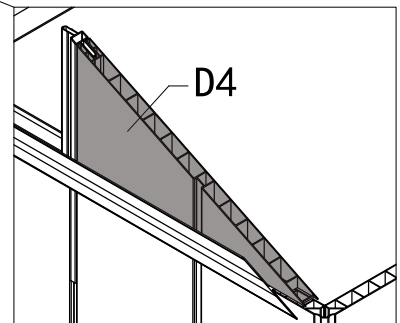
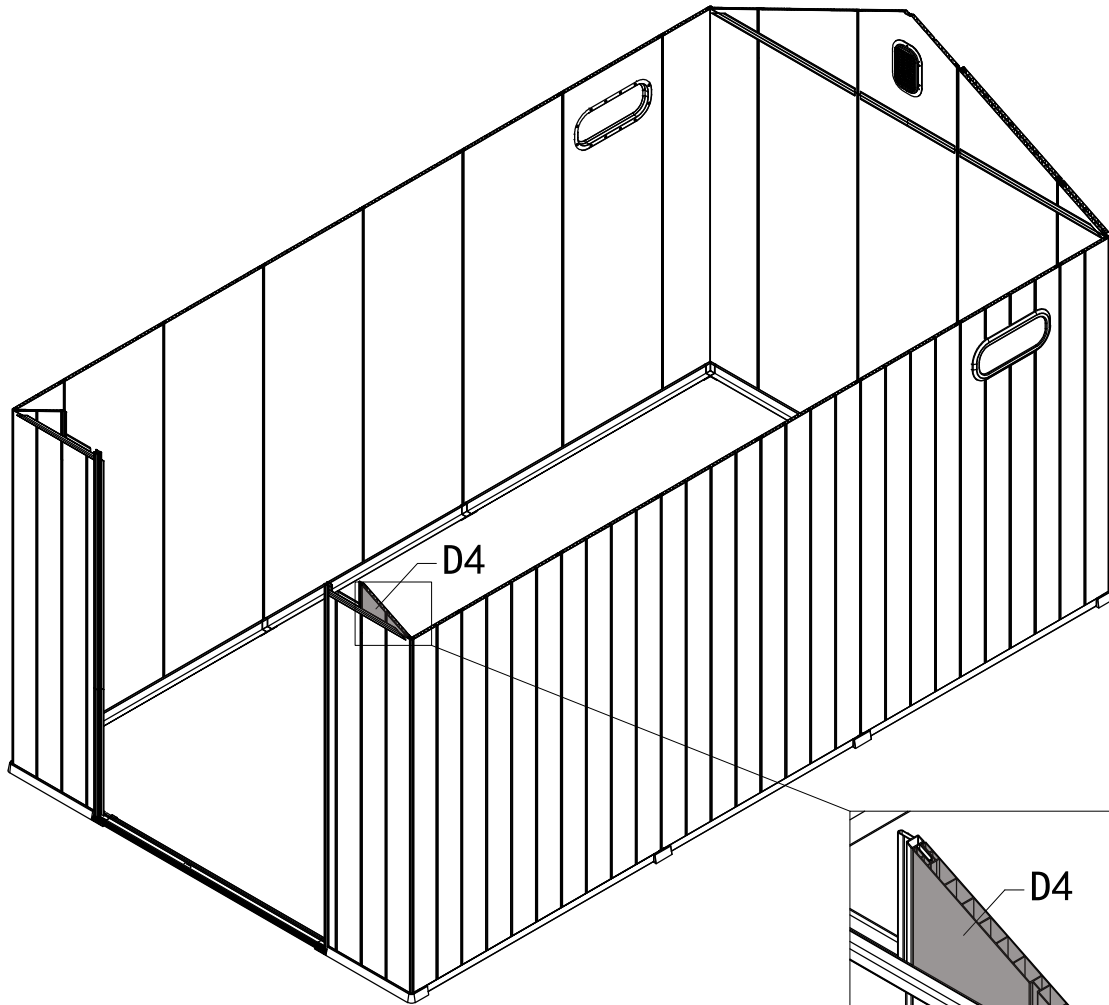

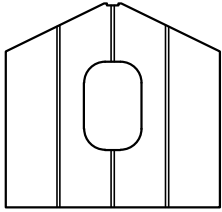

D-x1

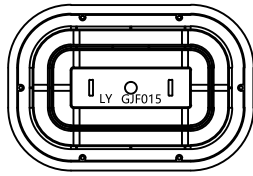

GJF015-x1

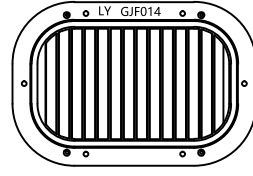

GJF014-x1



8# - x6

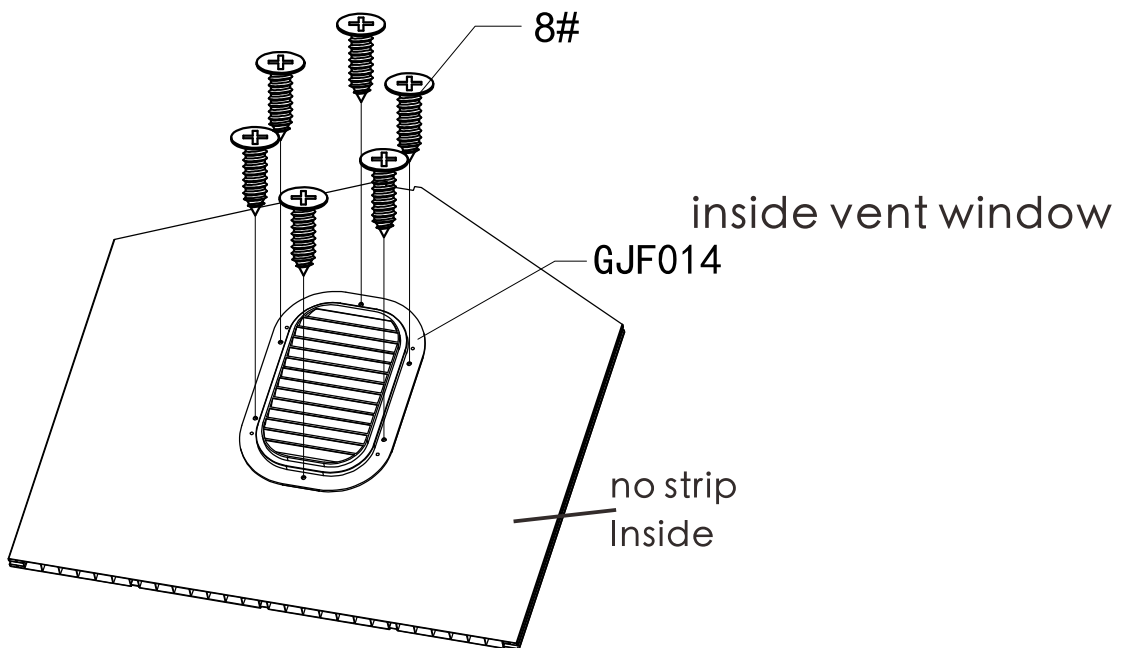
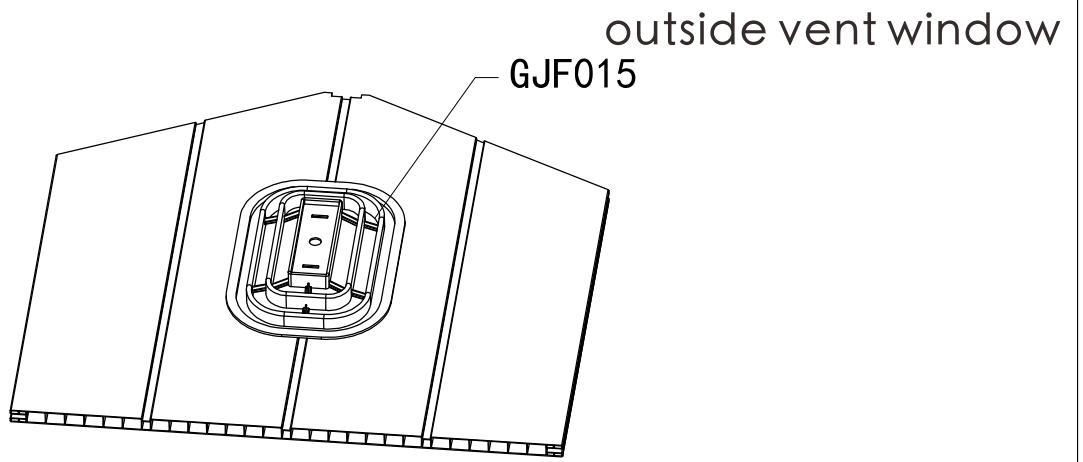
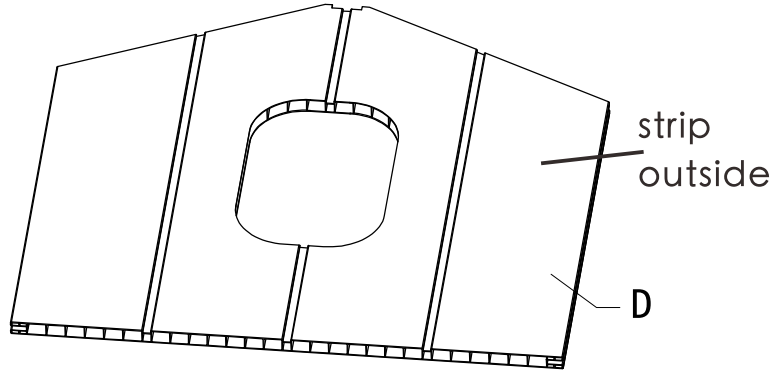

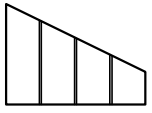

D2-x1

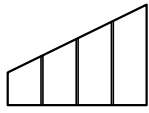

D1-x1

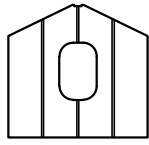

D-x1



C-x1



D5-x2

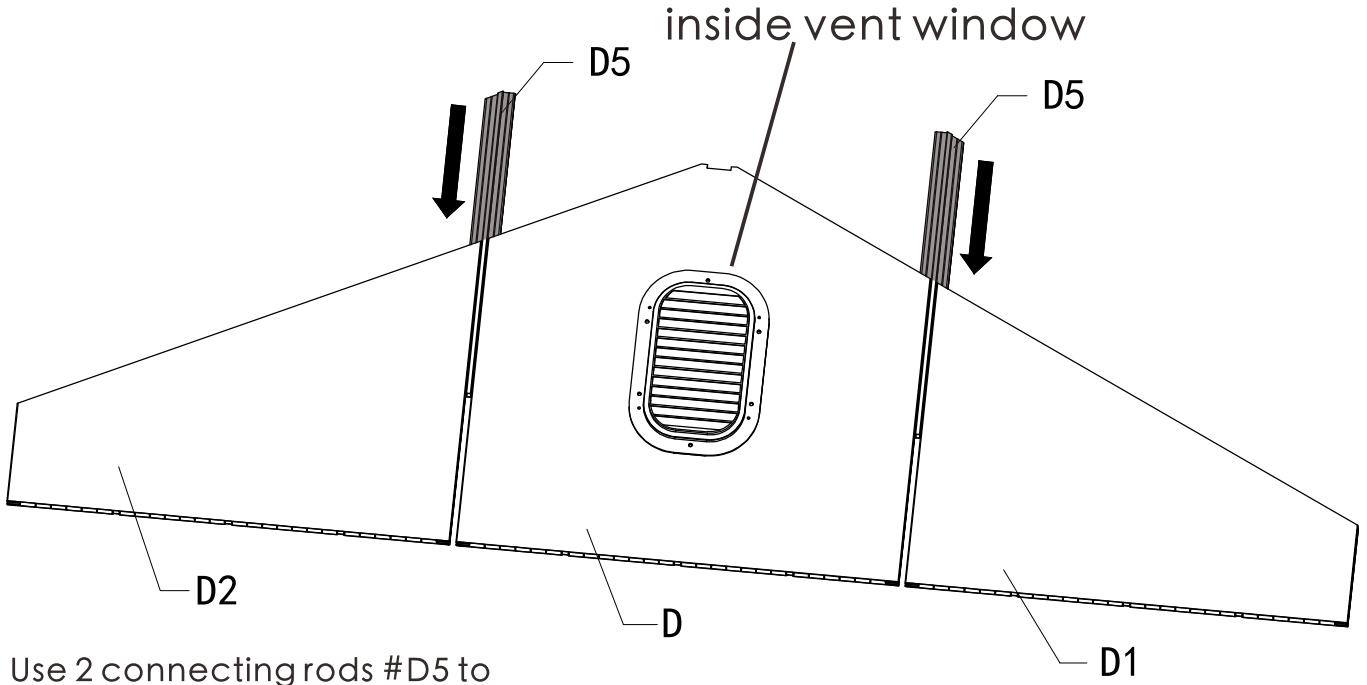

Use 2 connecting rods #D5 to connect #D2, D & D1, then slide top frame #C.

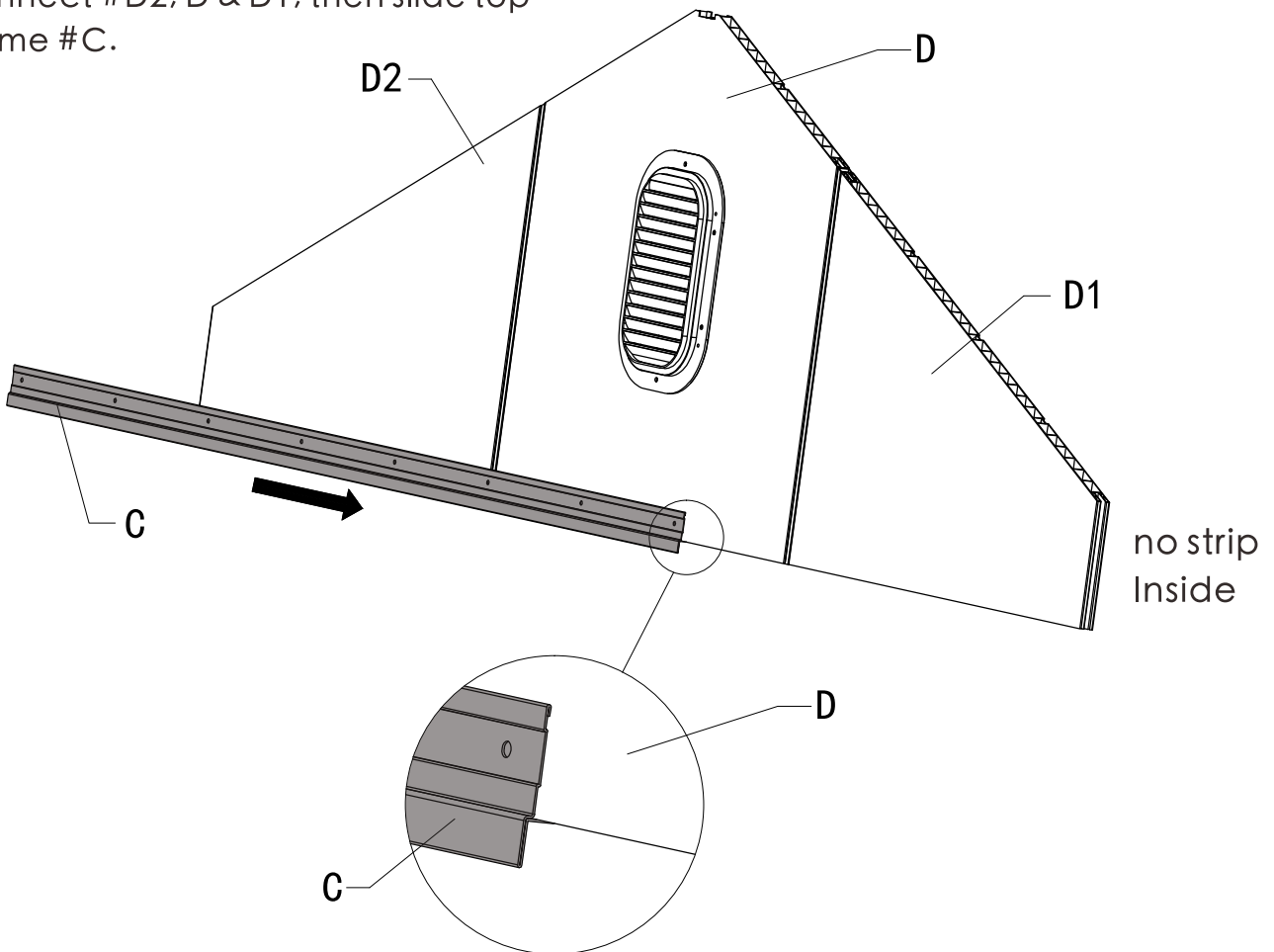

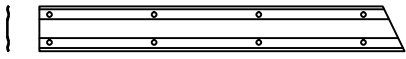

E1—x1

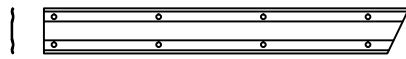

E2—x1



7# — x16

### INSIDE VIEW

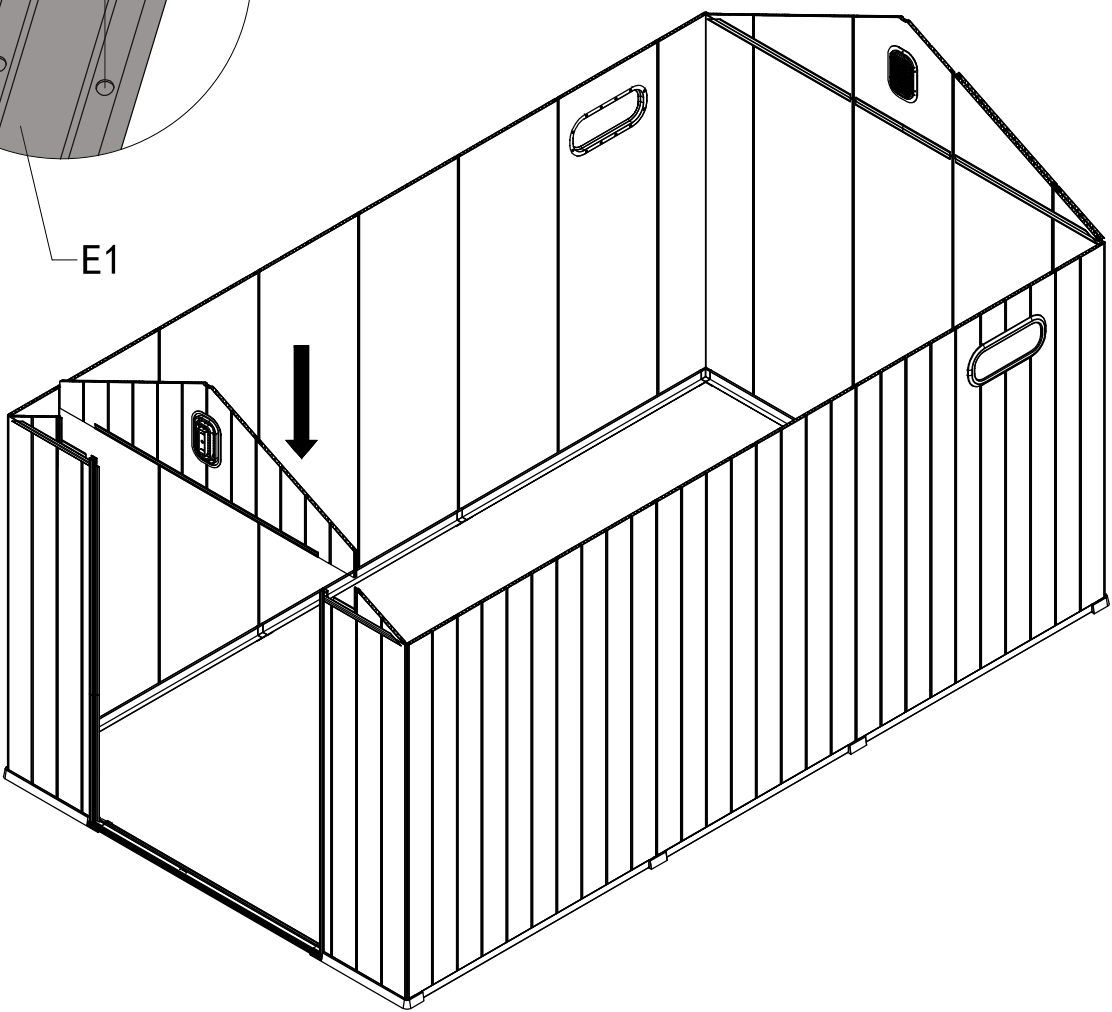
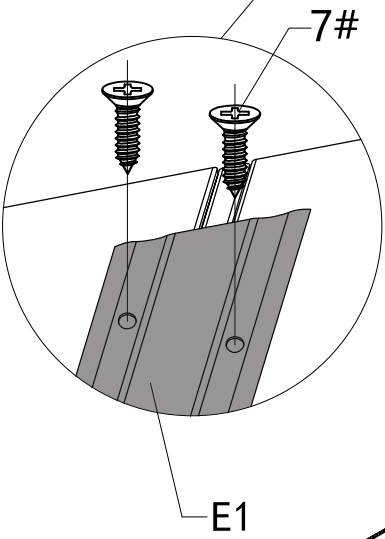
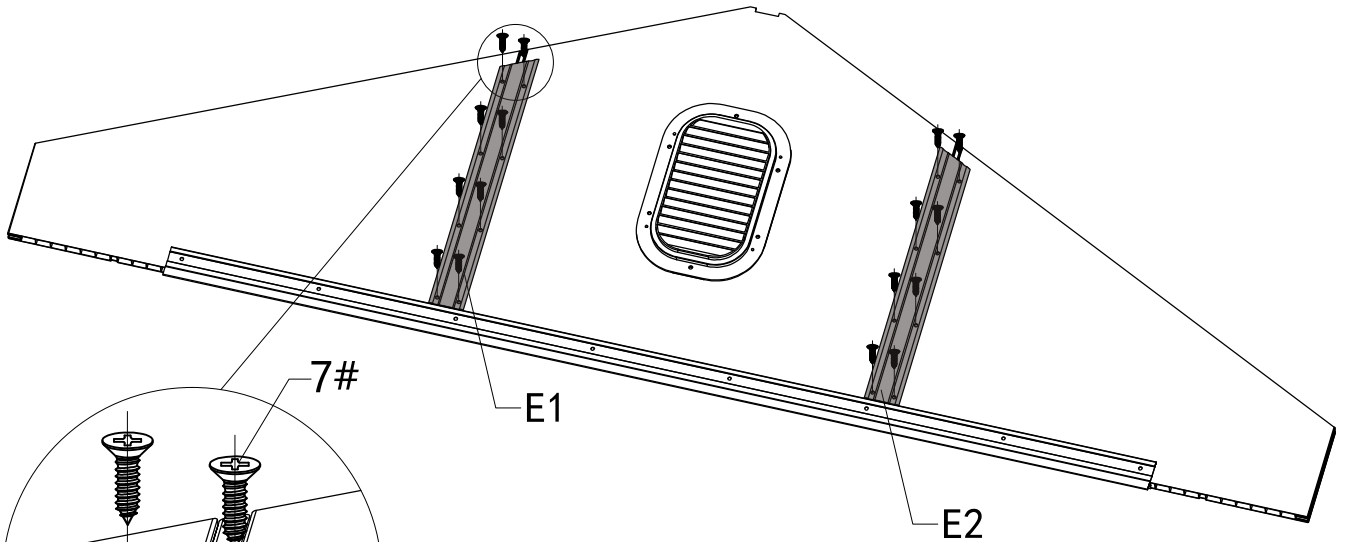



6# — x8



7# — x22

Use 8 screws 6# to secure top frame #C1 & C2 with front wall panels.

Use 22 screws 7# to secure top frame #C & #B1,B2 with front wall panels.

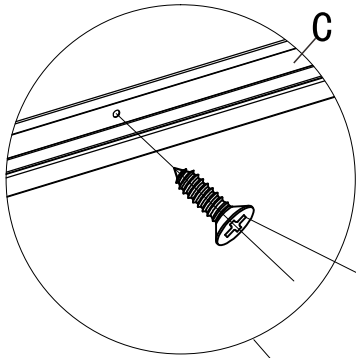

C

7#

C1/C2

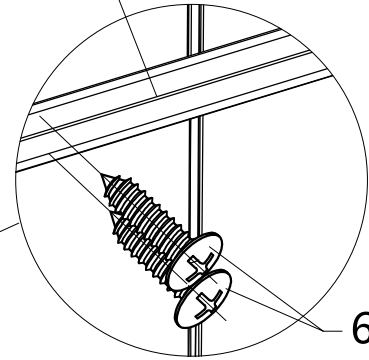

6#

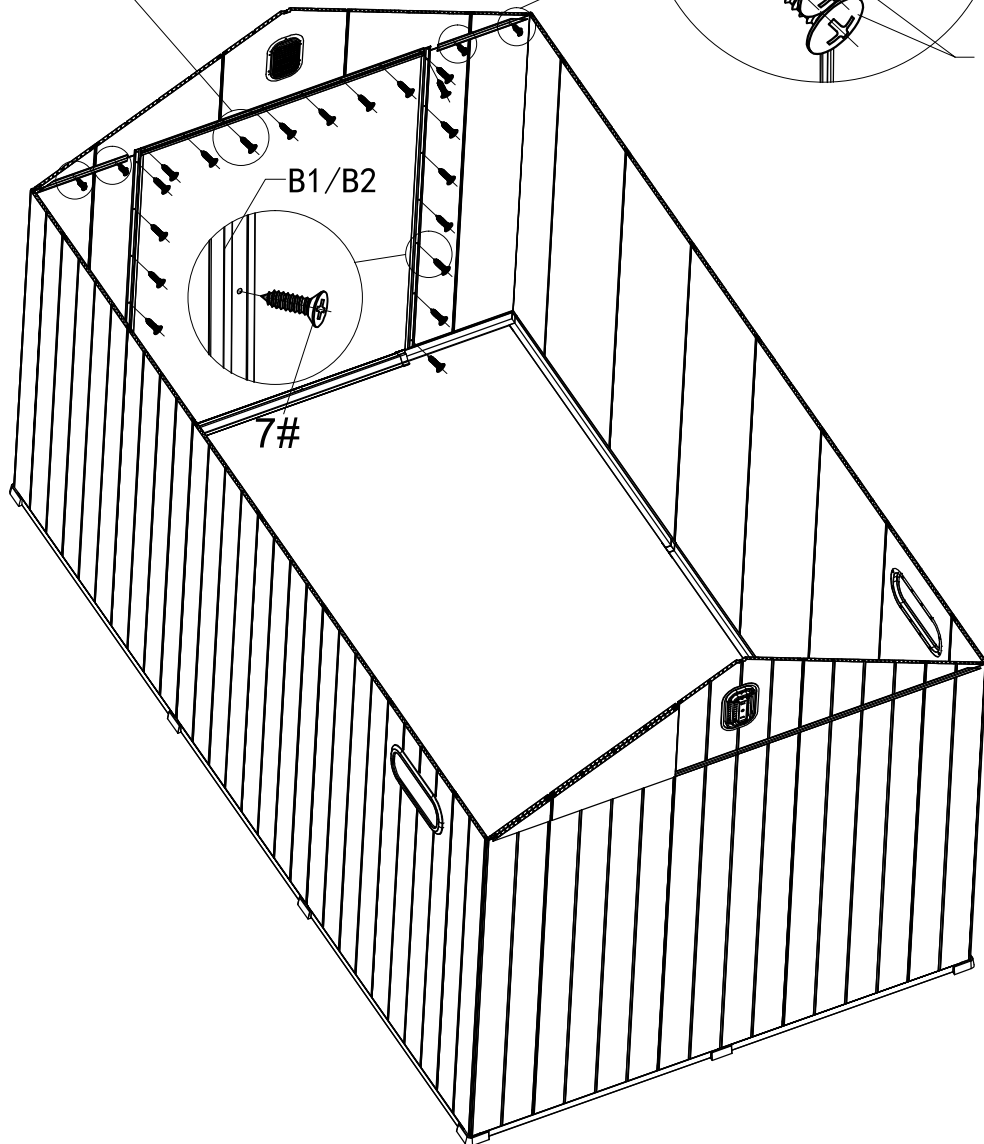

B1/B2

7#



13# - x2



Ø5.5 Q4 - x1

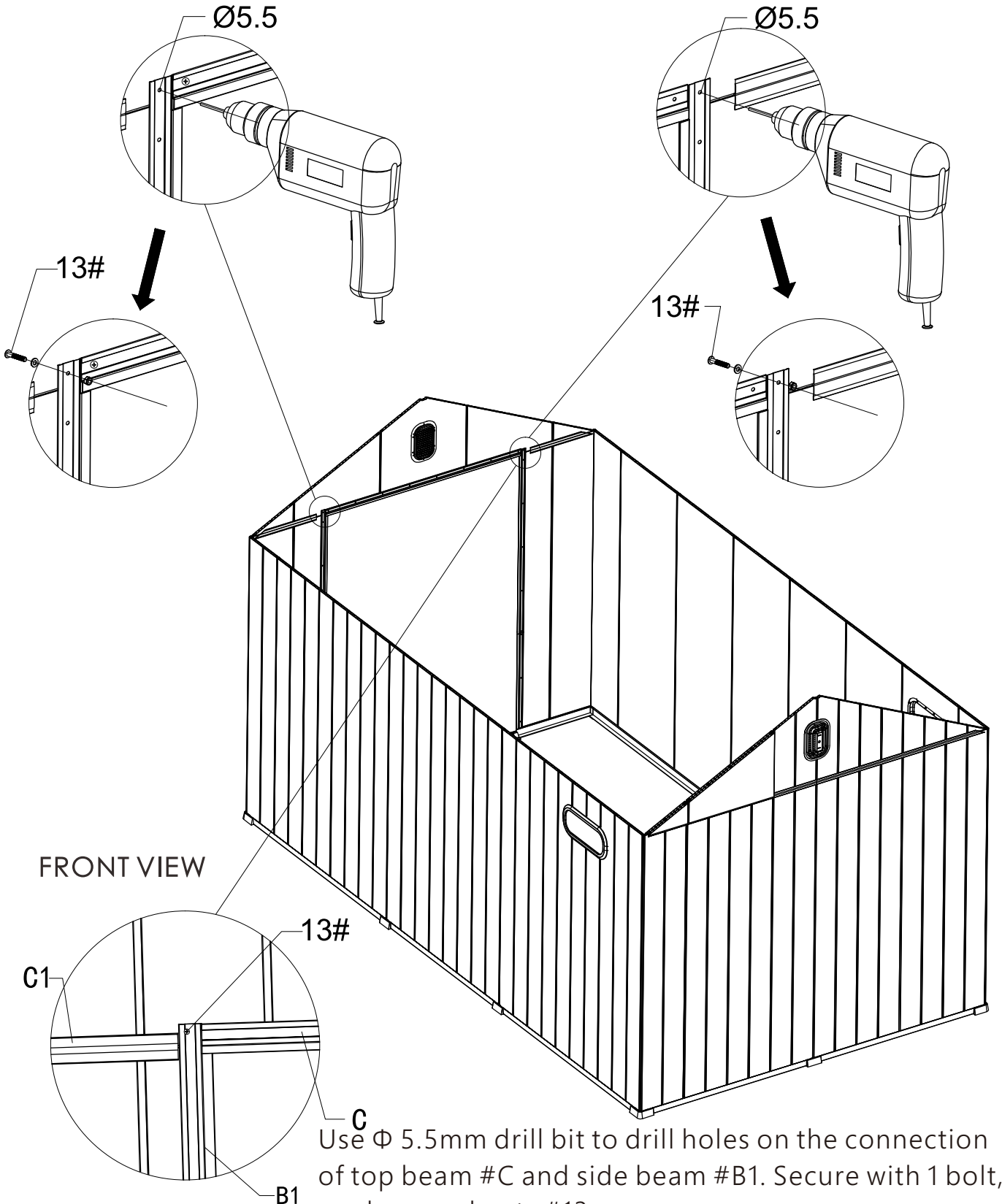

Use  $\Phi$  5.5mm drill bit to drill holes on the connection of top beam #C and side beam #B1. Secure with 1 bolt, washers and nuts #13.

Repeat above procedures to assemble another side.

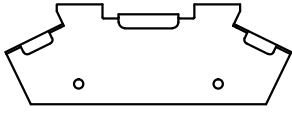

E - x2

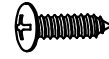

6# - x4

Connect #E and Component #D with 4 screws 6# as shown.

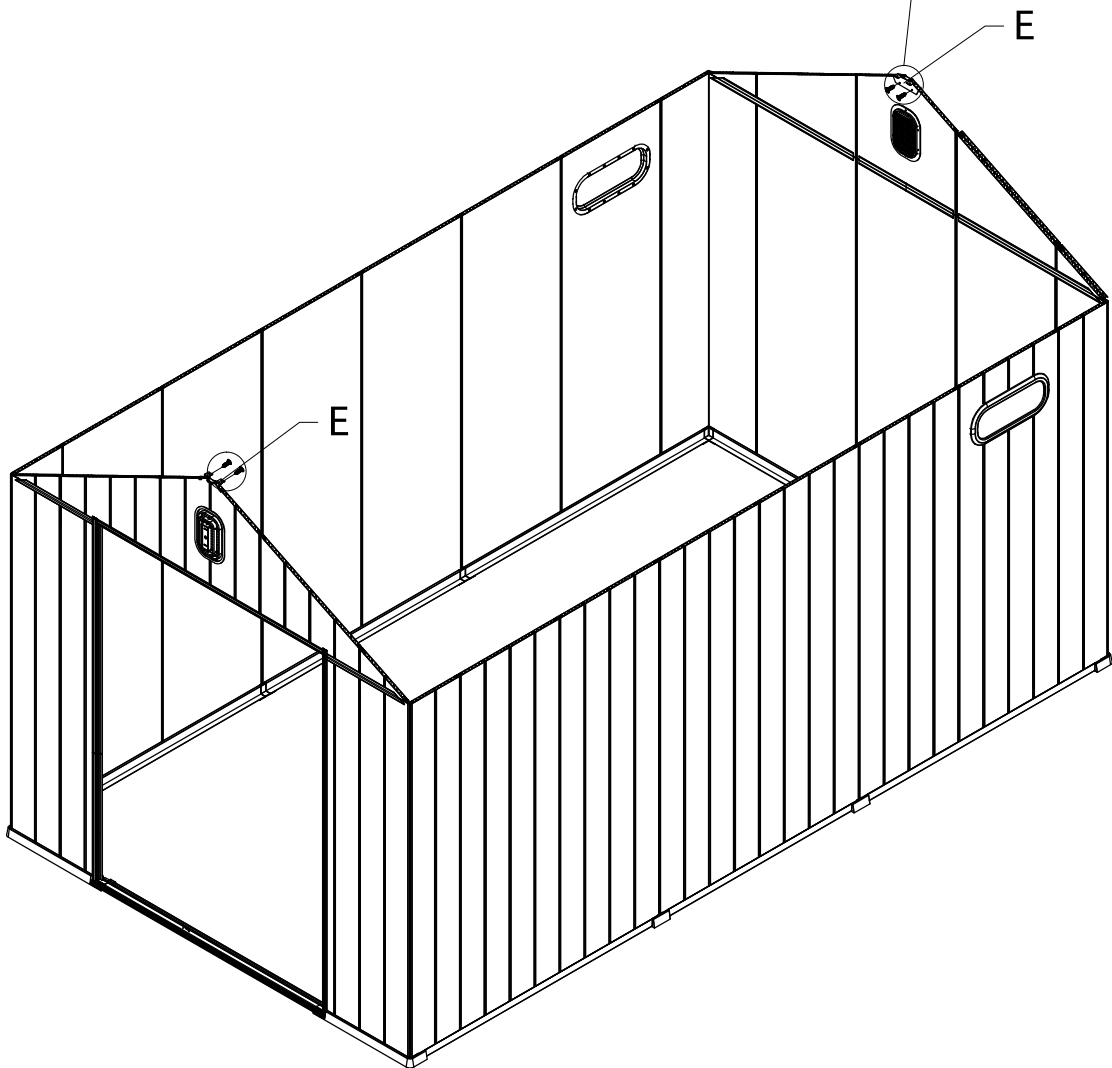
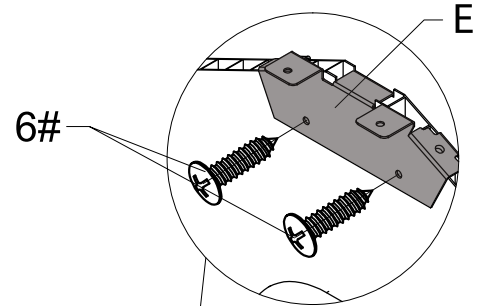

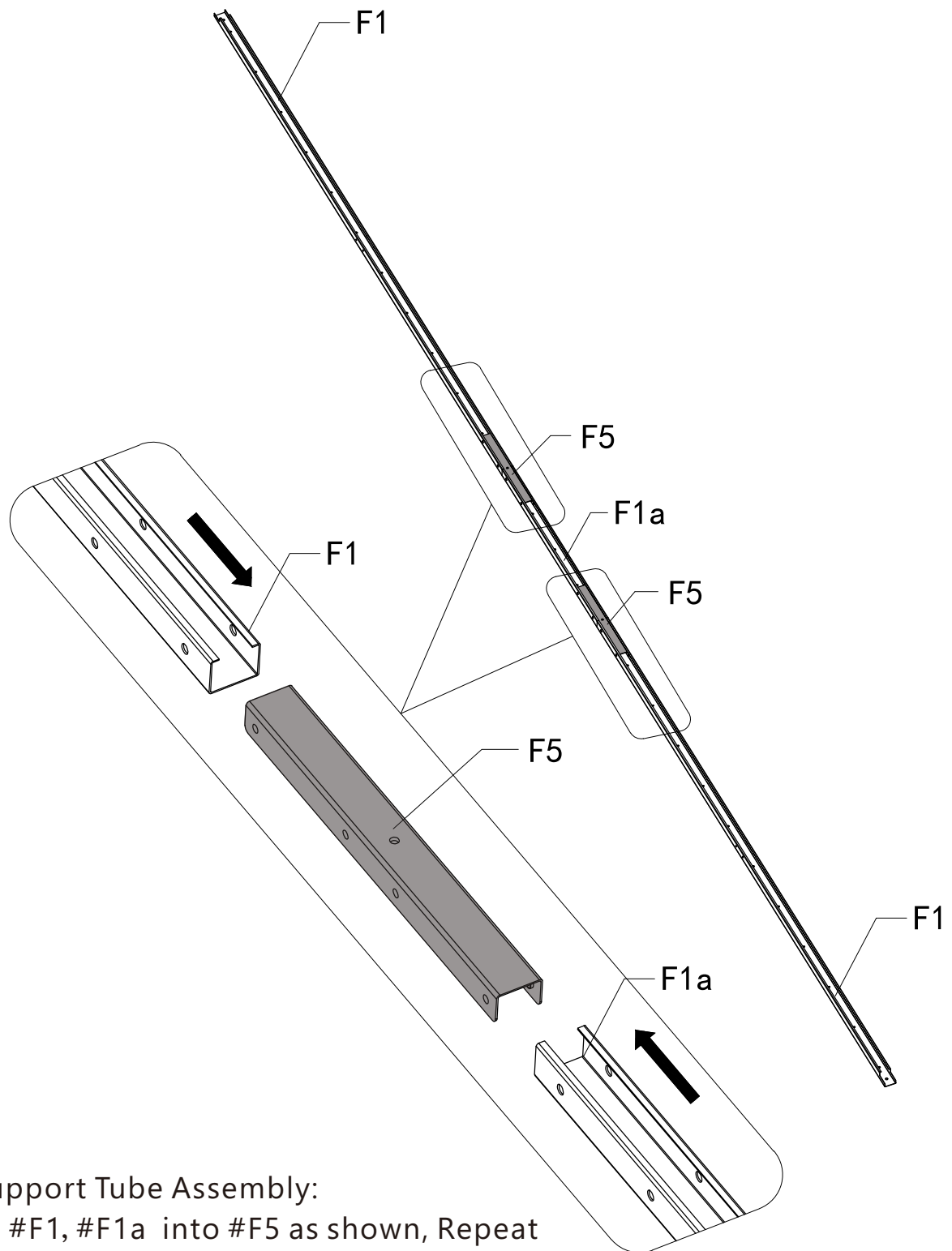
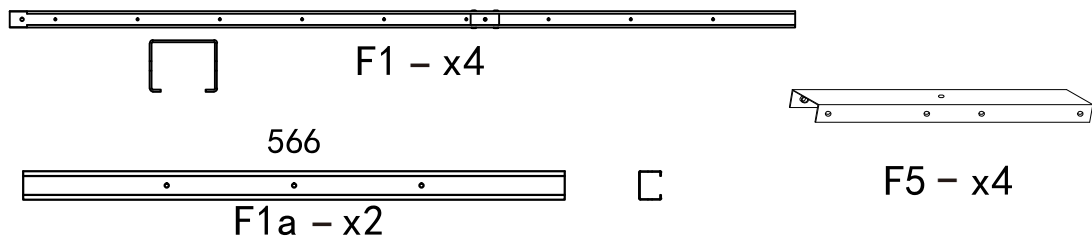

Roof Support Tube Assembly:  
 Insert 2 #F1, #F1a into #F5 as shown, Repeat  
 above step to assemble the remained  
 #F1, #F1a and #F5.



1# – x32

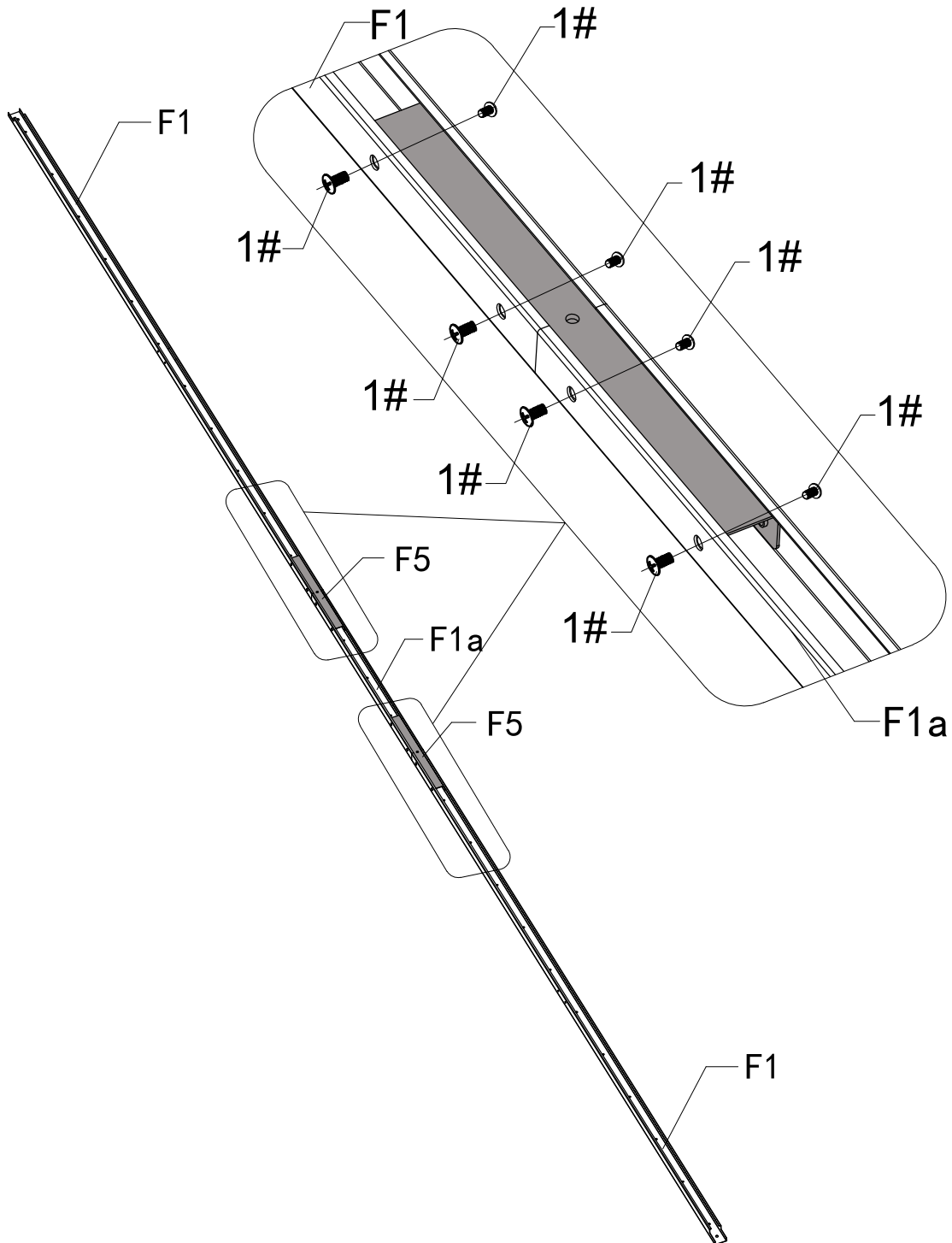

Use 8 bolts #1 to fix #F1,#F1a and #F5. Repeat above step to fix the remained #F1,#F1a and #F5.

Assemble 2 connected #F1 with #E.

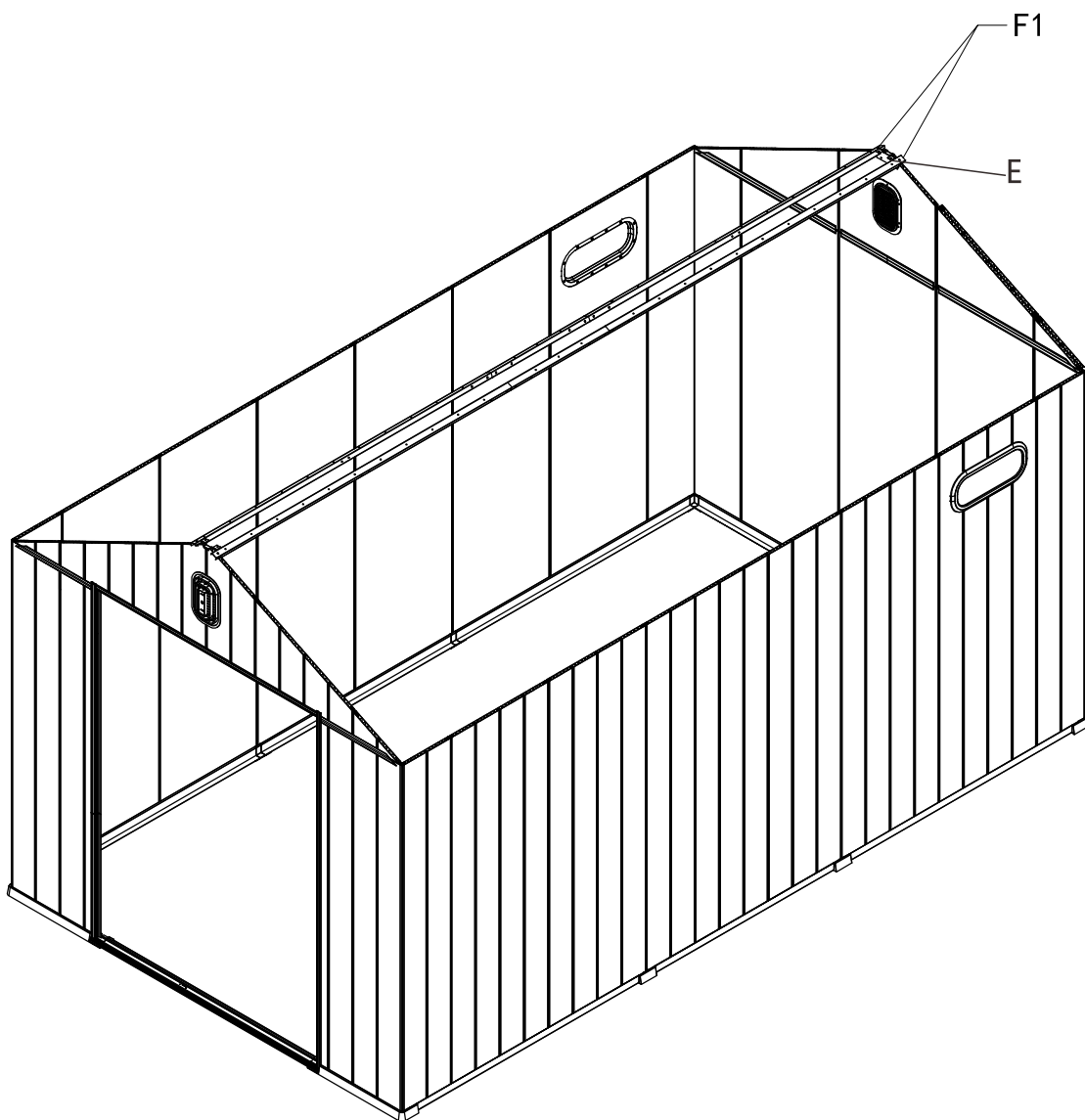

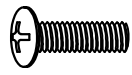

2# — x4

Insert 4 bolts 2# to fix #F1 onto #E.

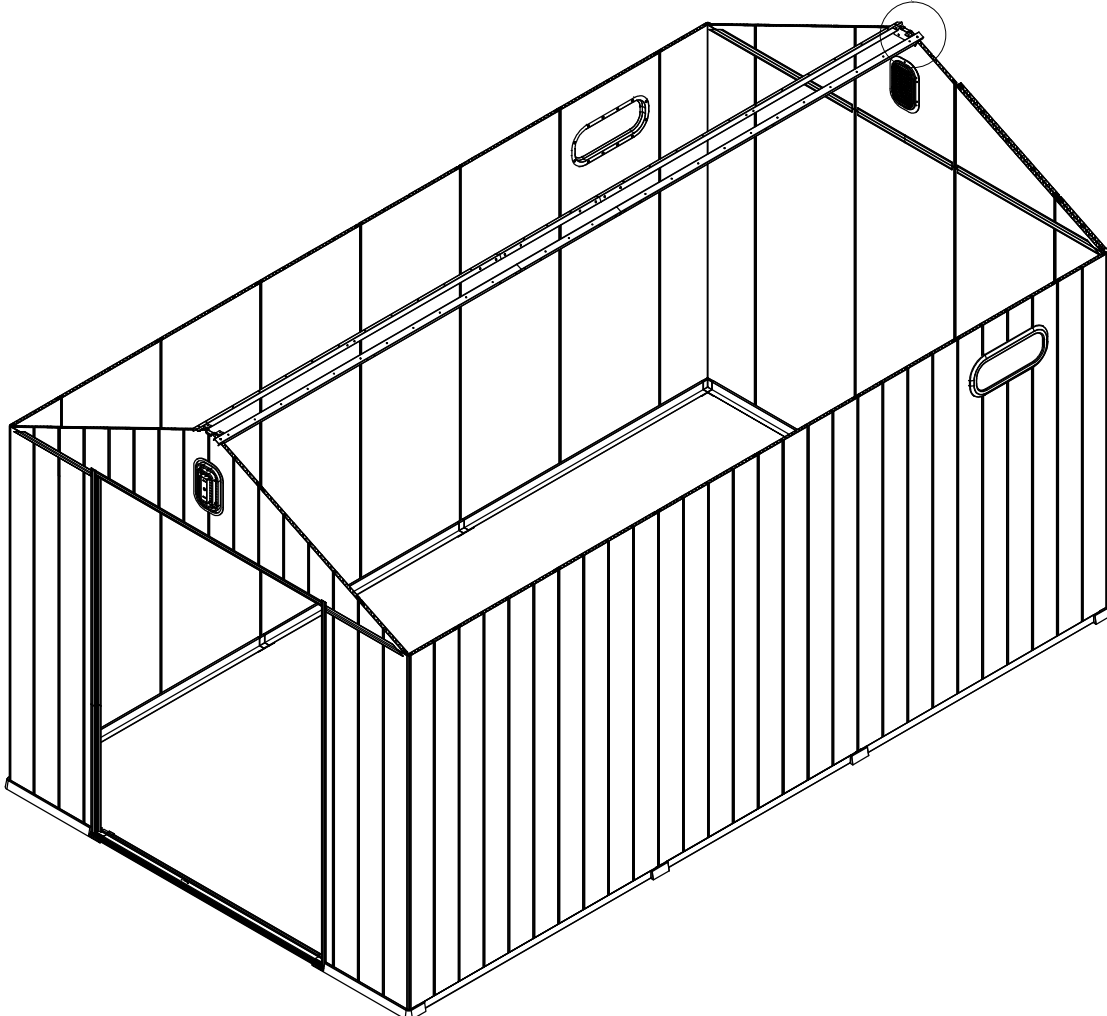
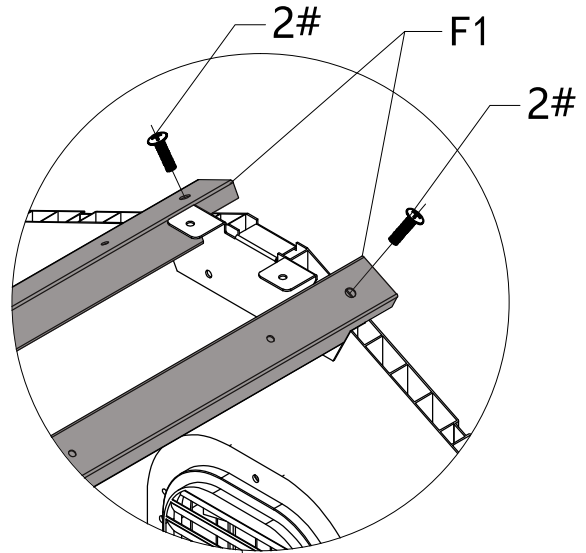



Z - x1

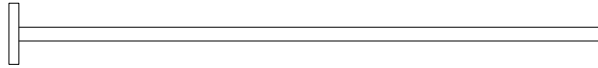

Z1 - x1

Connect the pole #Z with the pole #Z1 as the temporary supporting pole.

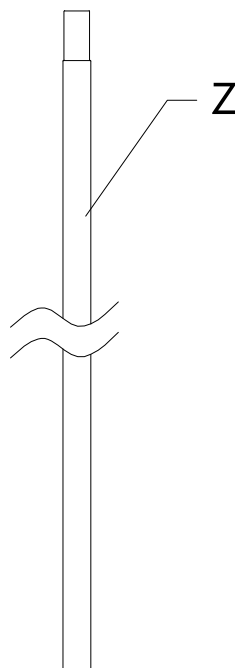
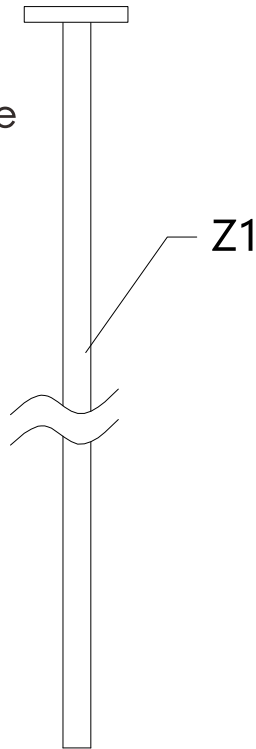

#Z and #Z1 are temporary supports,  
to be removed after use.

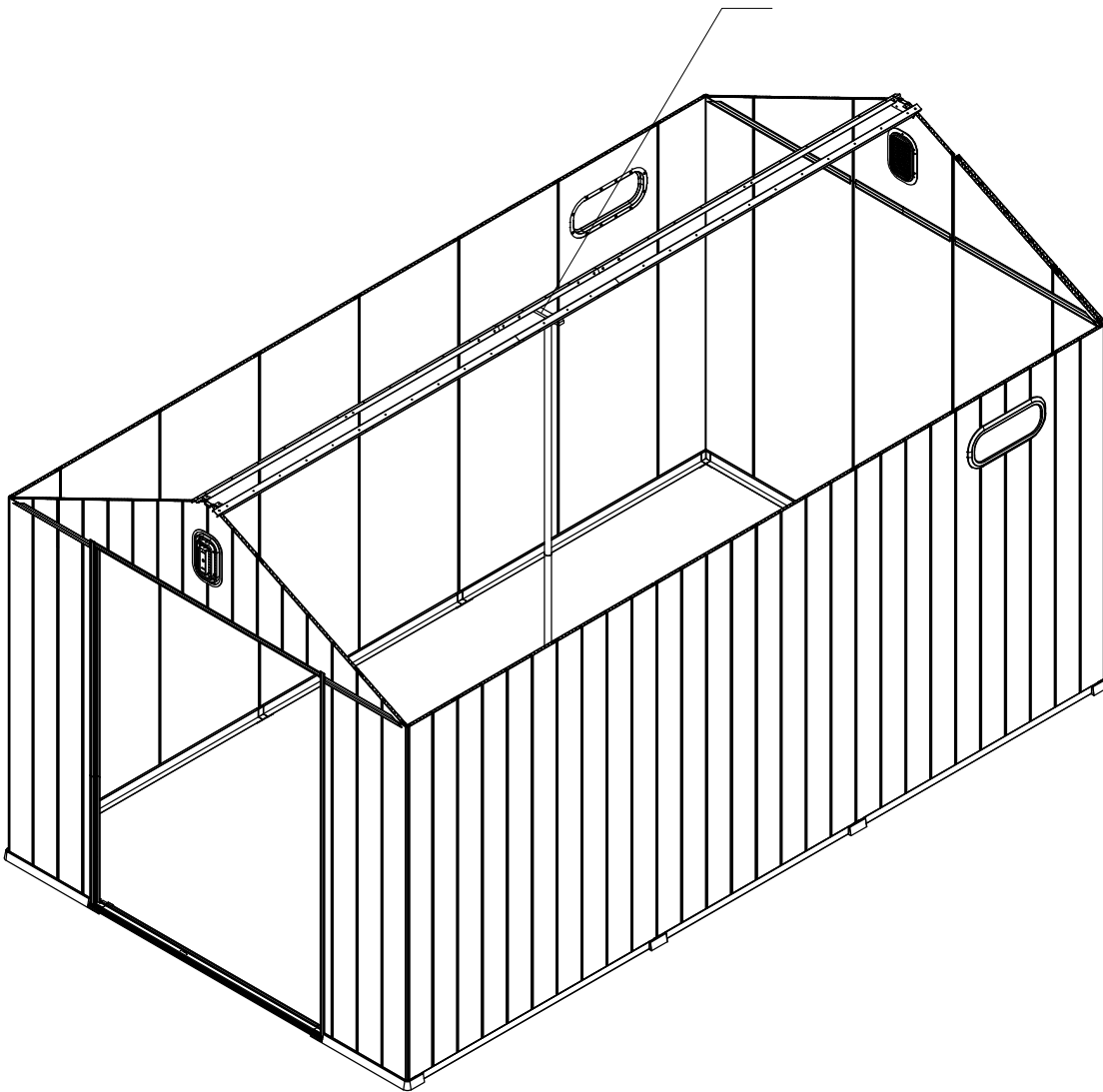

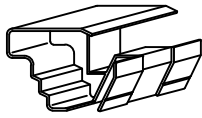

GJF004-x4

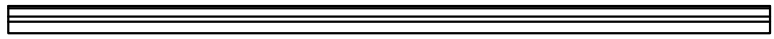

F2 - x4

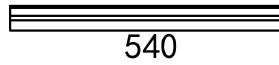

540



F2a - x2

Assemble the side top frame:

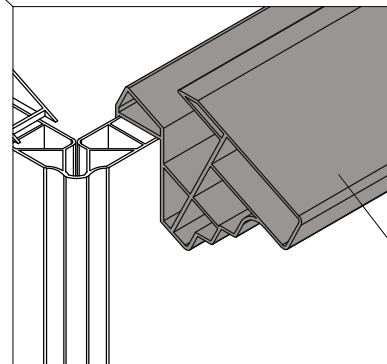
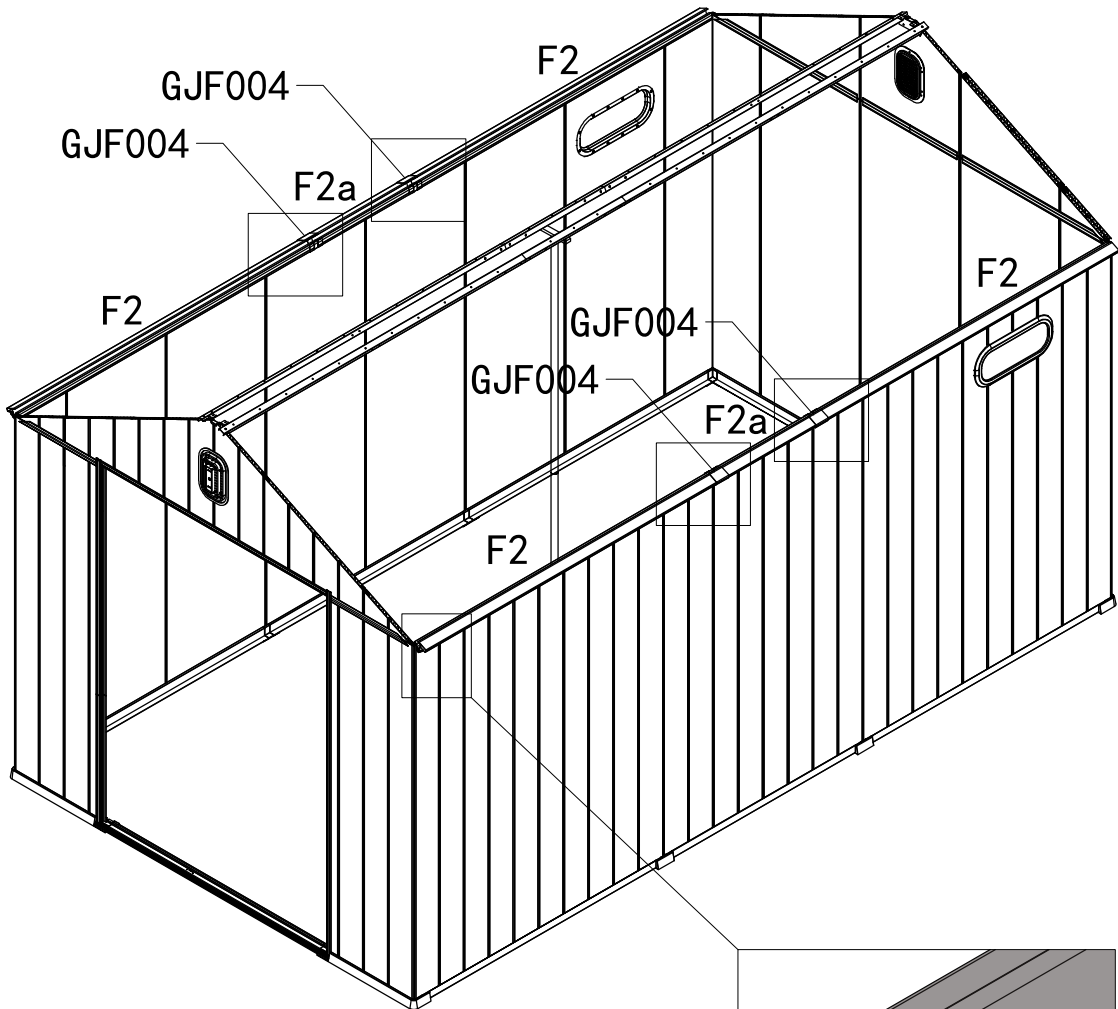
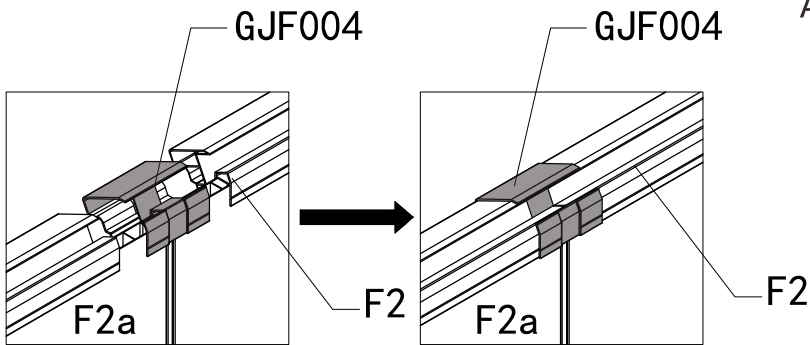

F2

Insert #GJF004 with 2 #F2 and #F2a. Repeat above process to assemble the other part.



F4 - x4

Assemble 4 #F4.

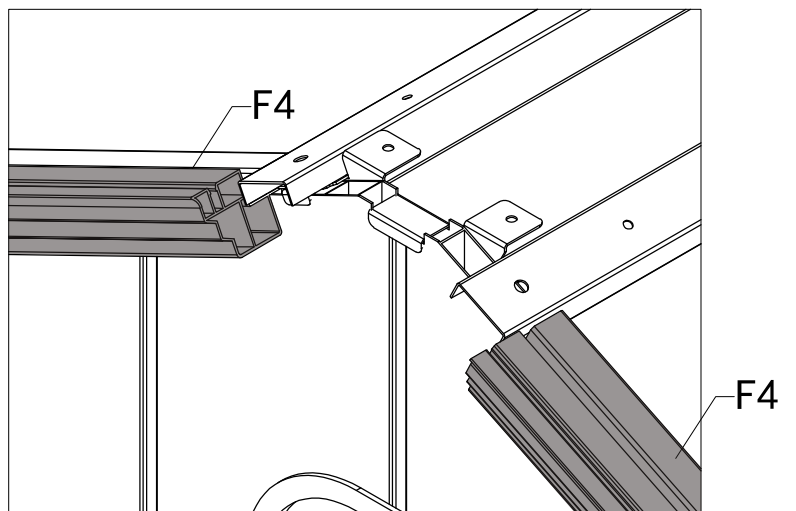
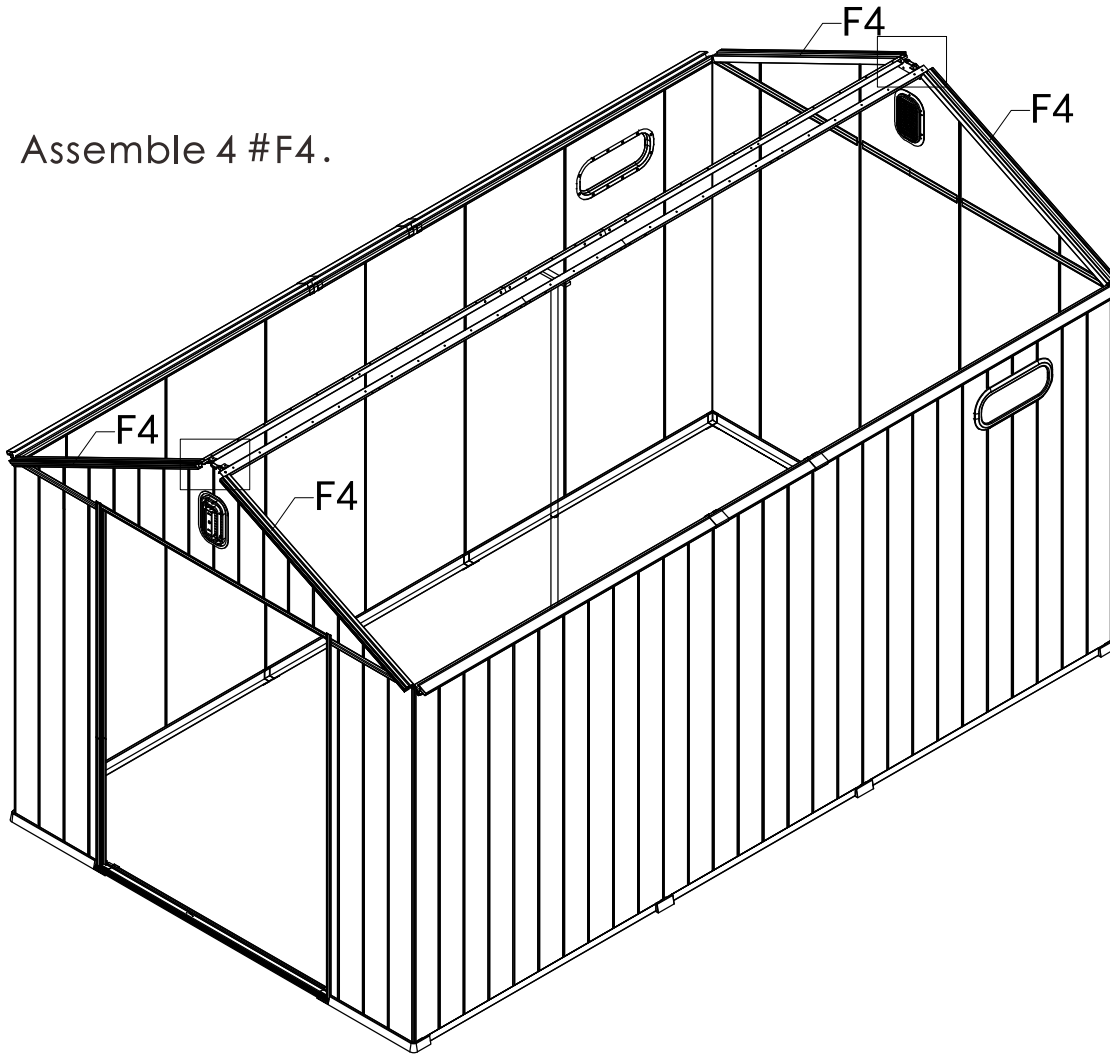

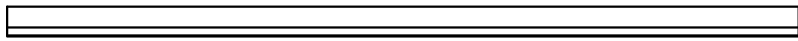

F - x2



562

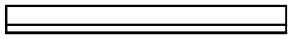

Fa - x1

GJF005-x2

Y - x1

Assemble #F and #Fa with #GJF005, then seal the joint with sealant #Y.

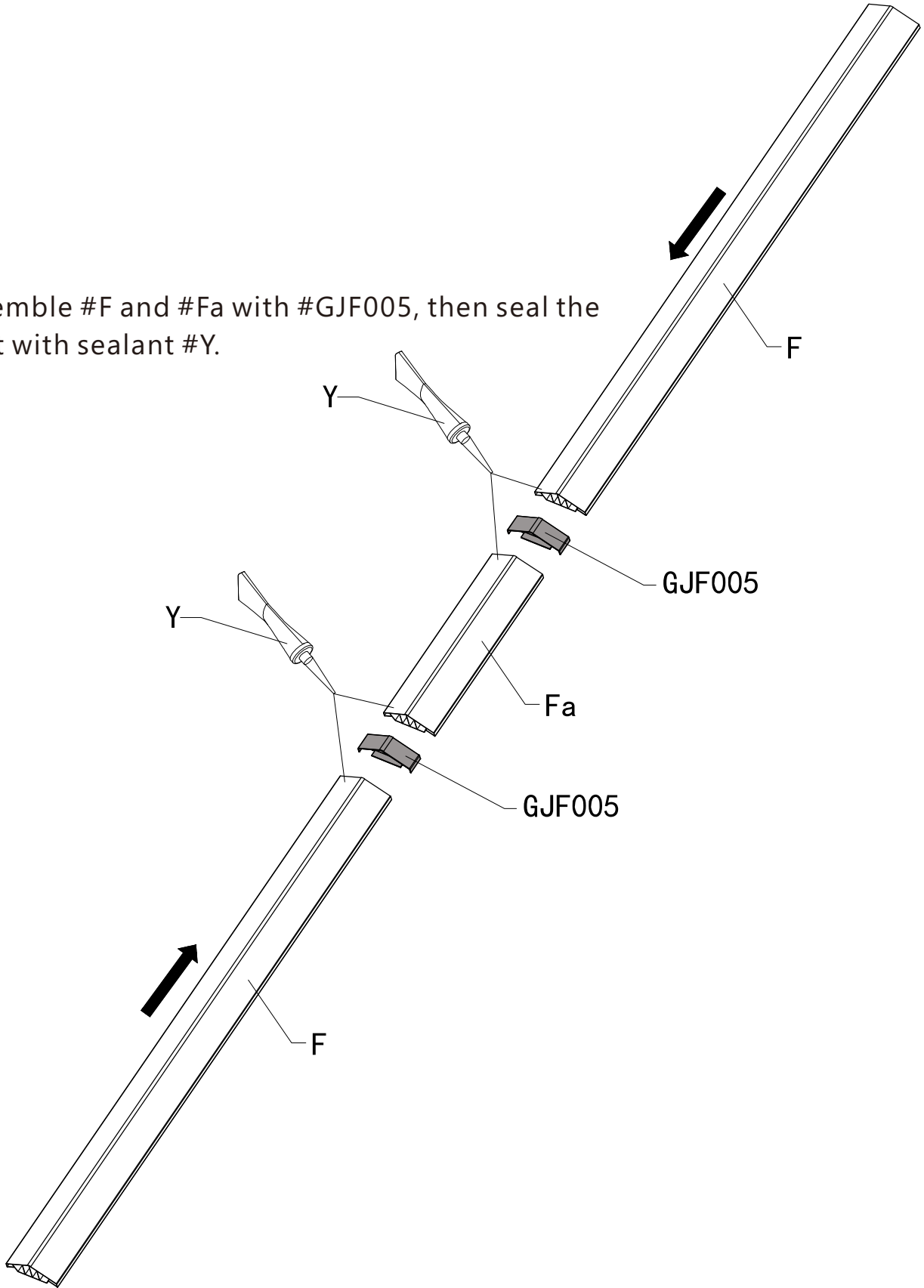

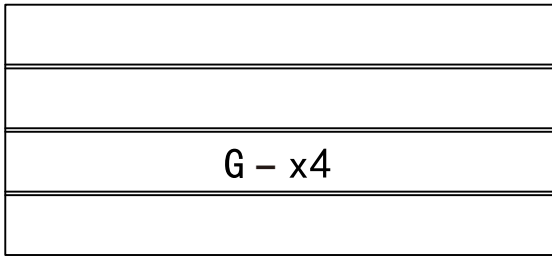

4# - x10

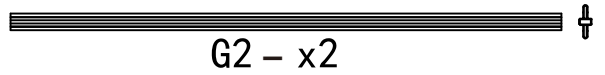

Insert roof panels into the groove of #F2/F2a.

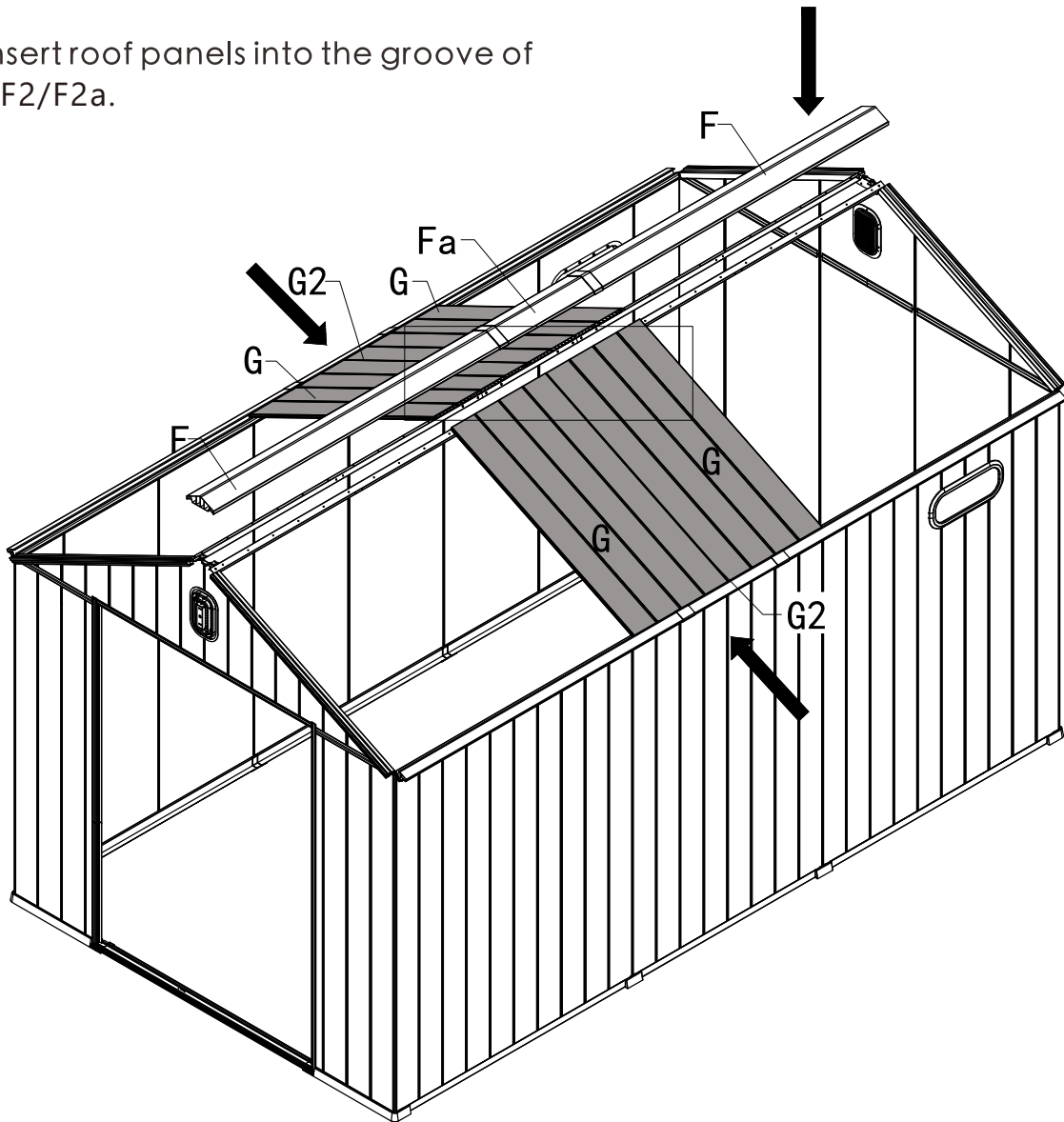

Cover on roof cover #F and #Fa. Secure roof support tube #F1 and #F1a, roof panel #G and #G2 and roof cover #F through 10 screws #4 (from bottom to top).

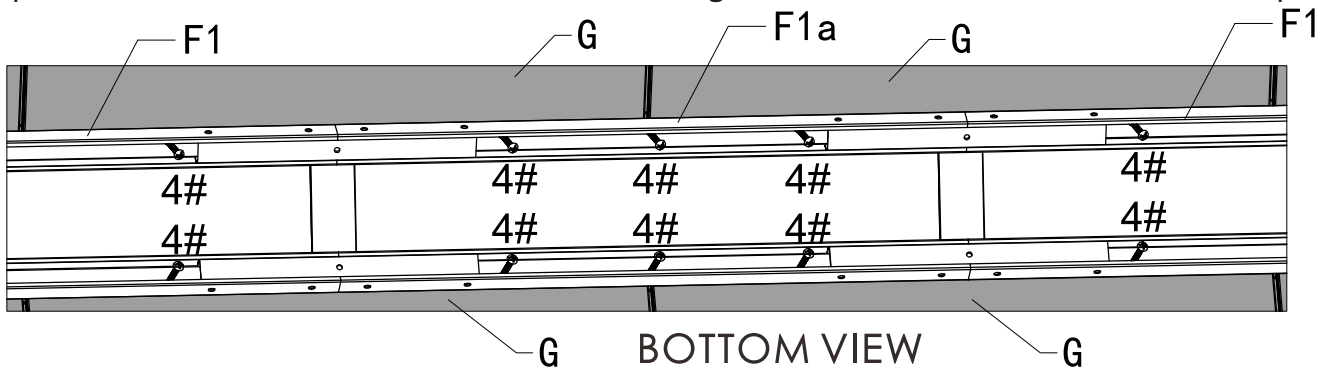

Note: Roof panel #G is aligned with support tube #F1 and #F1a edges.

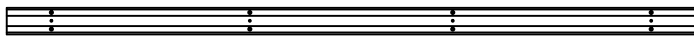

G3 - x6



7# - x48

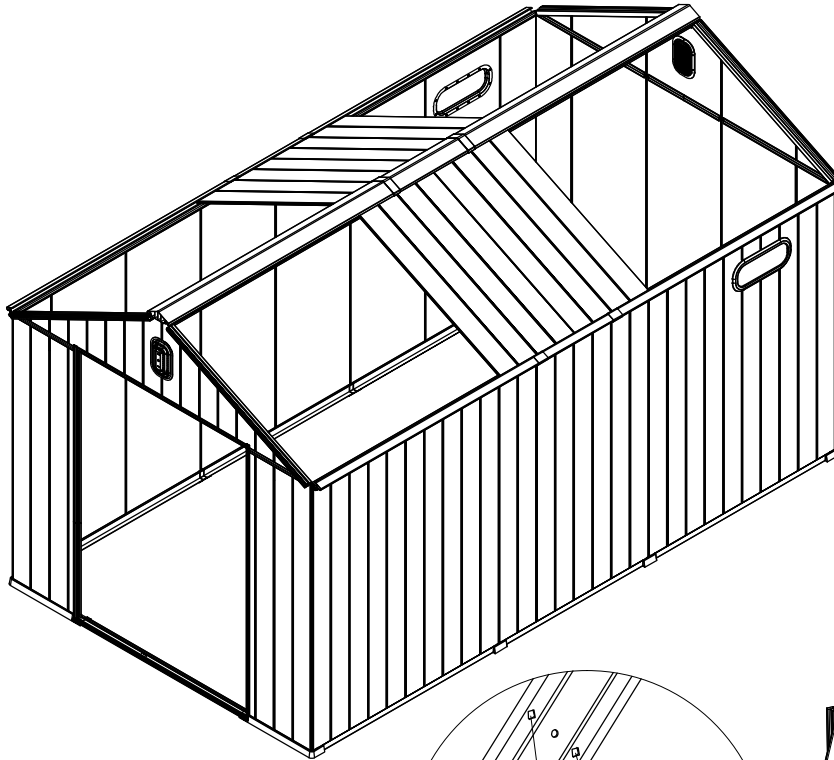

Use 8 screws 7# to secure roof supporting bar #G3 at the splicing of 2 roof panels #G and #G2 (from inside). Repeat the above steps to assemble the other sides.

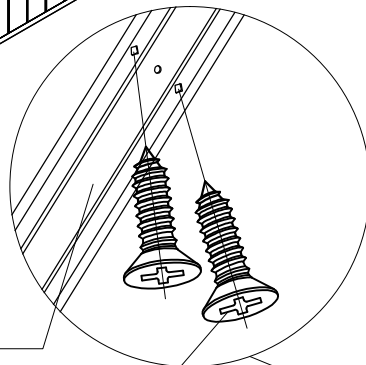

G3

7#

G3

G3

7#

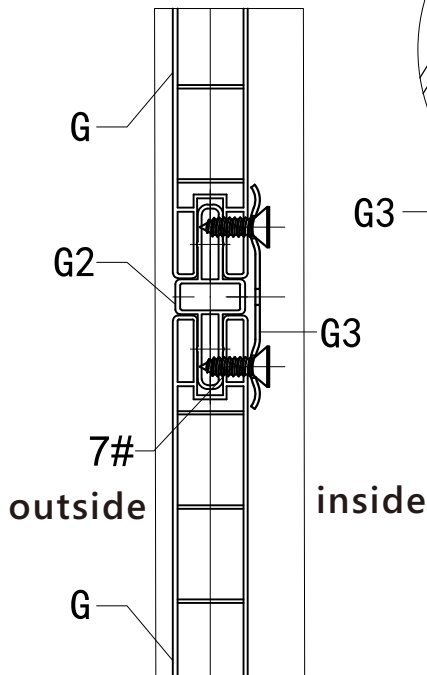

G

G2

G3

inside

7#

outside

G

### SECTION VIEW

Note: The upper end of #G3 is aligned with support tube #F1/F1a edges.

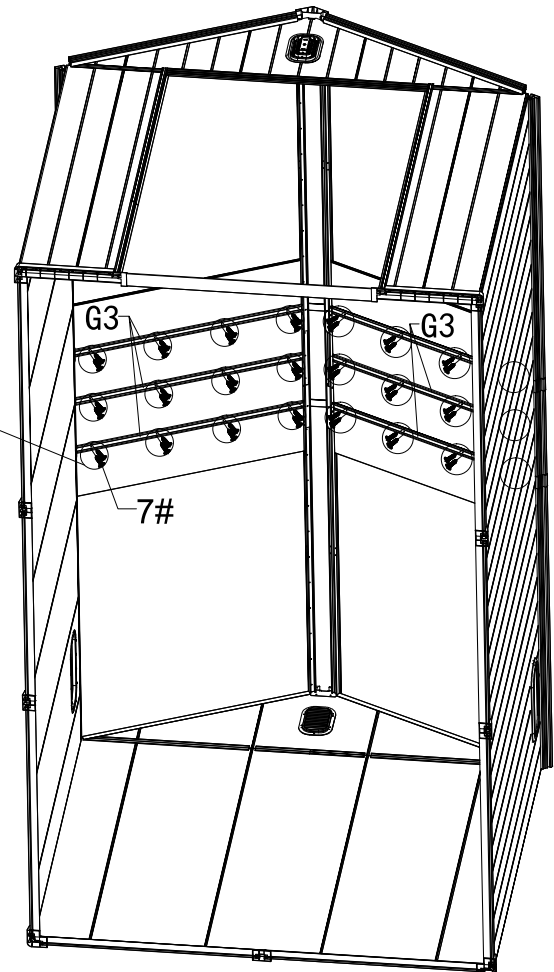

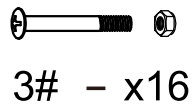
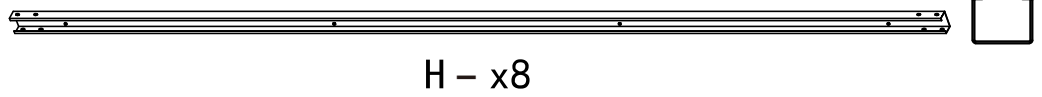
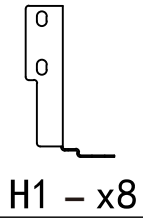

Secure #H and #H1 with 2 bolts #3 and nuts as shown.  
Repeat above steps to assemble remained parts.

**SECTION VIEW**

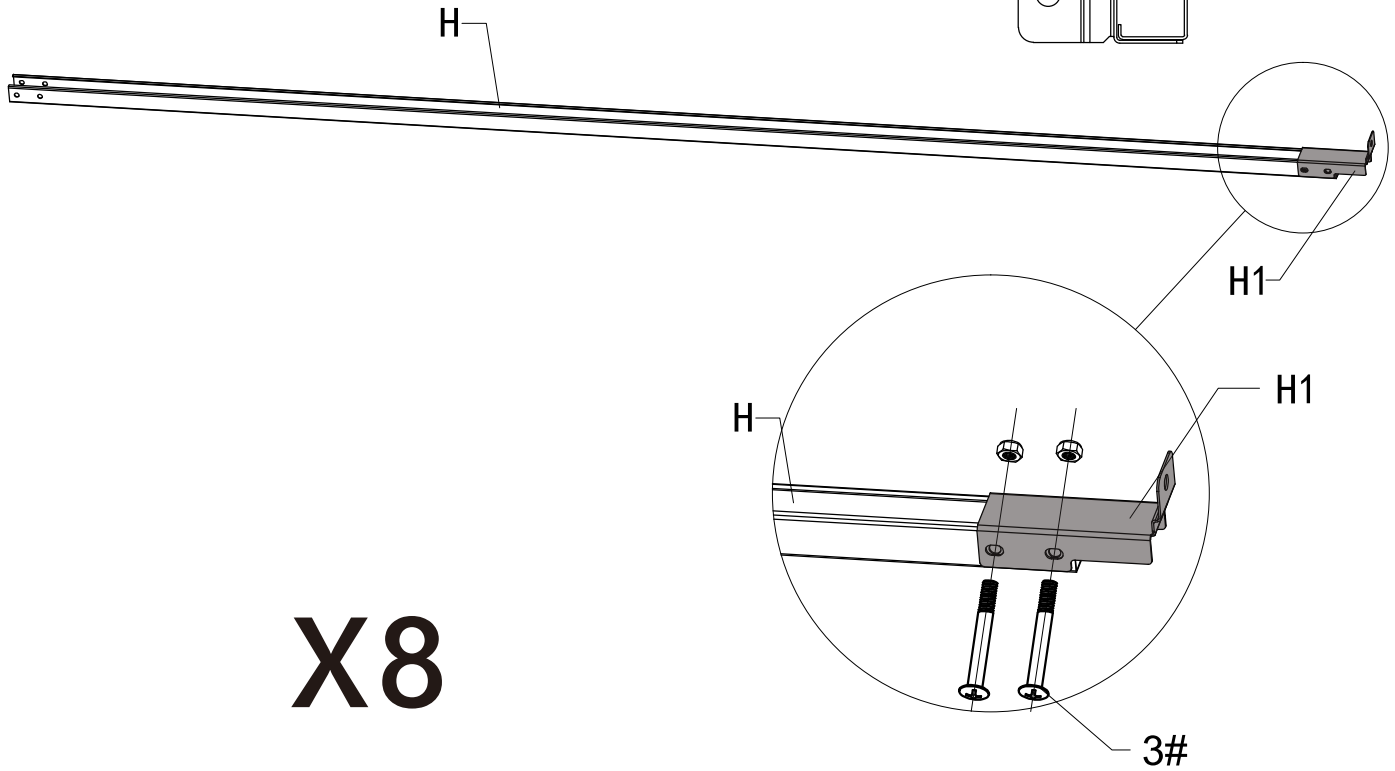
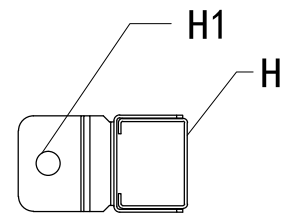

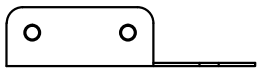

J2 - x8

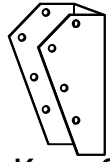

K - x8

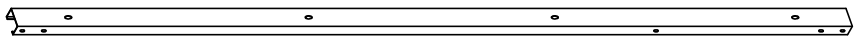

J - x8



3# - x16



1# - x32

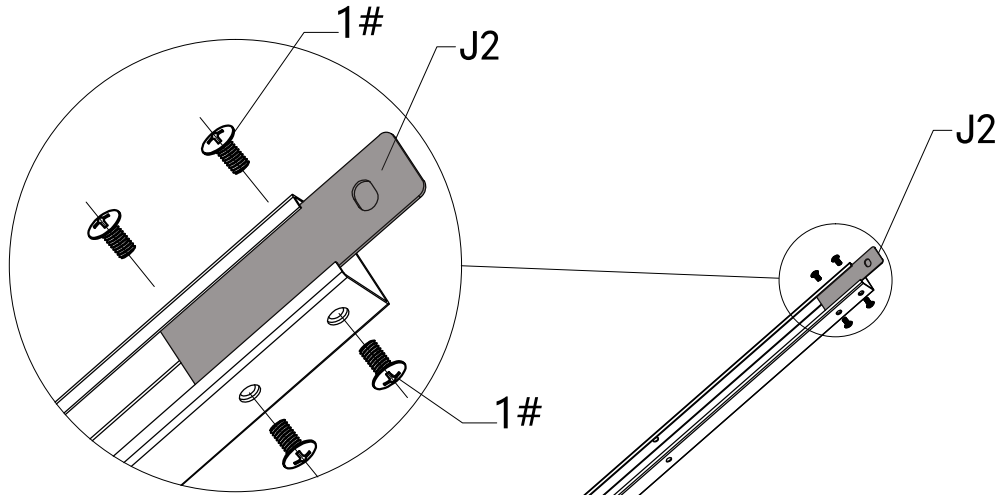

Secure #J2 and #J with 4 bolts 1# as shown.

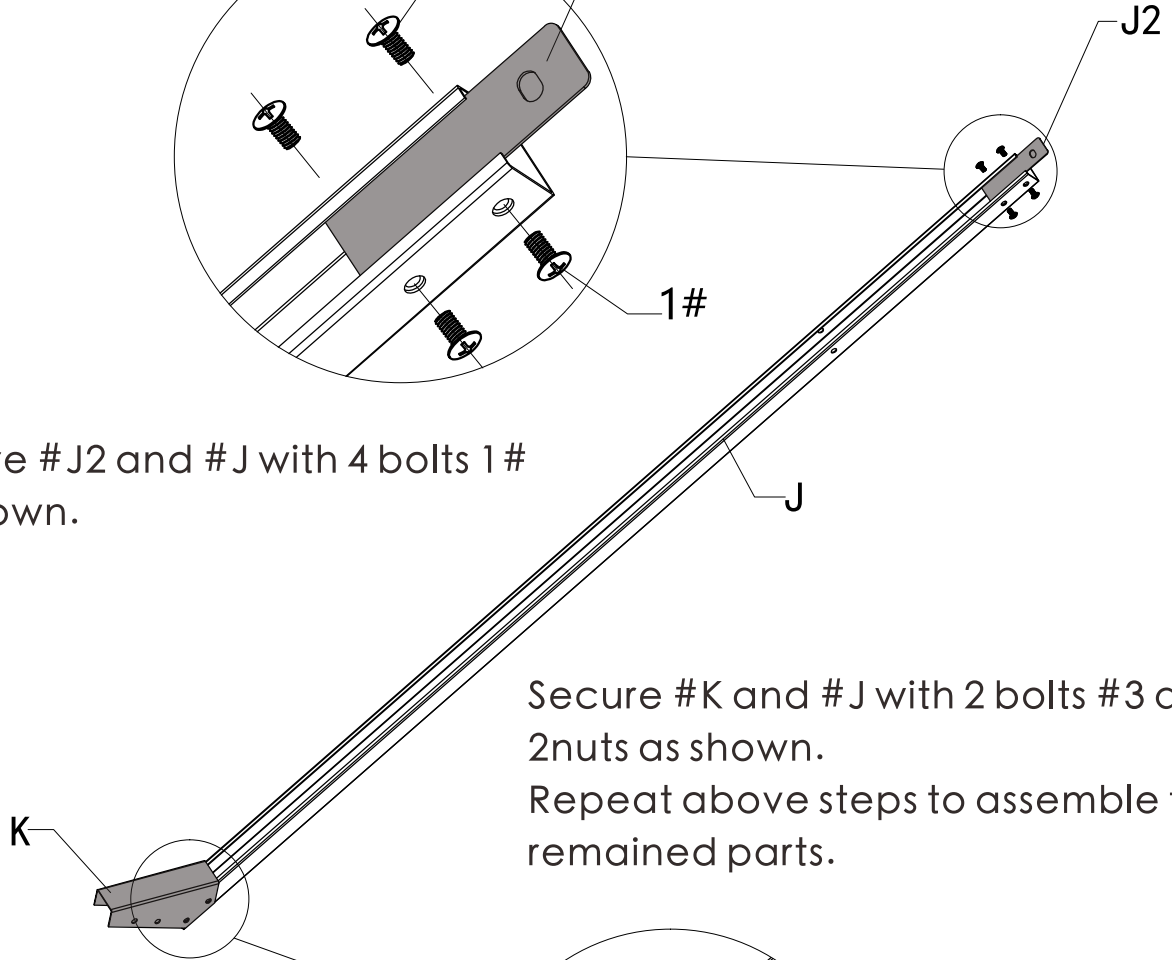

Secure #K and #J with 2 bolts #3 and 2nuts as shown.

Repeat above steps to assemble the remained parts.

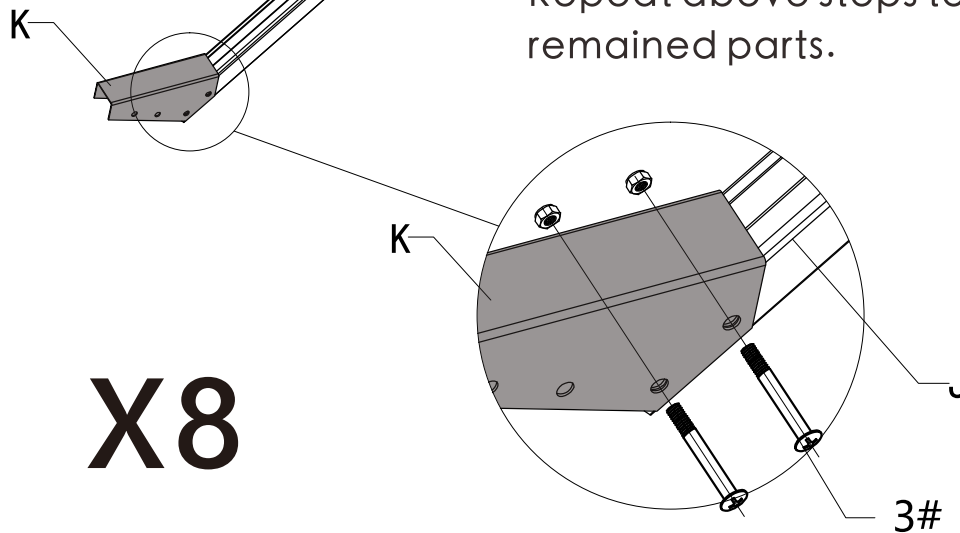

**X8**

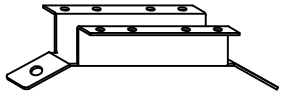

L - x2



3# - x8



7# - x64

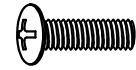

2# - x4

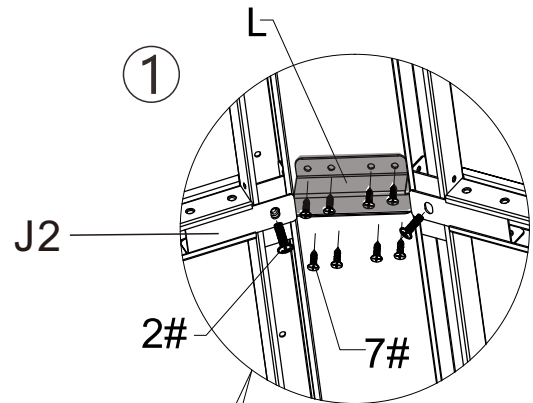
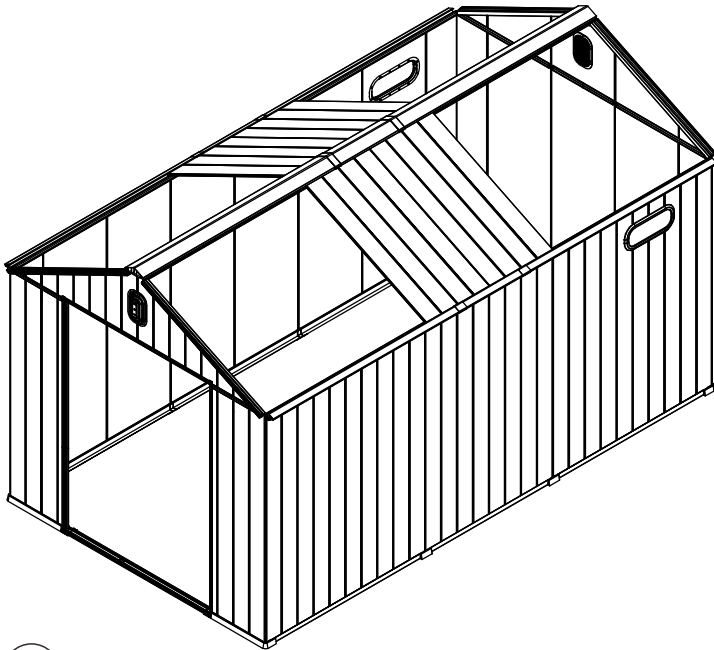

2

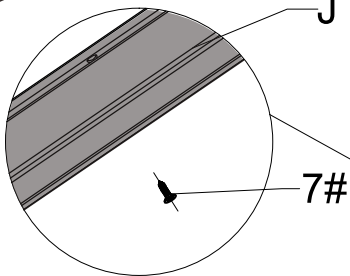

3

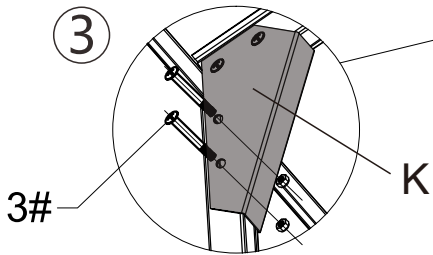

4

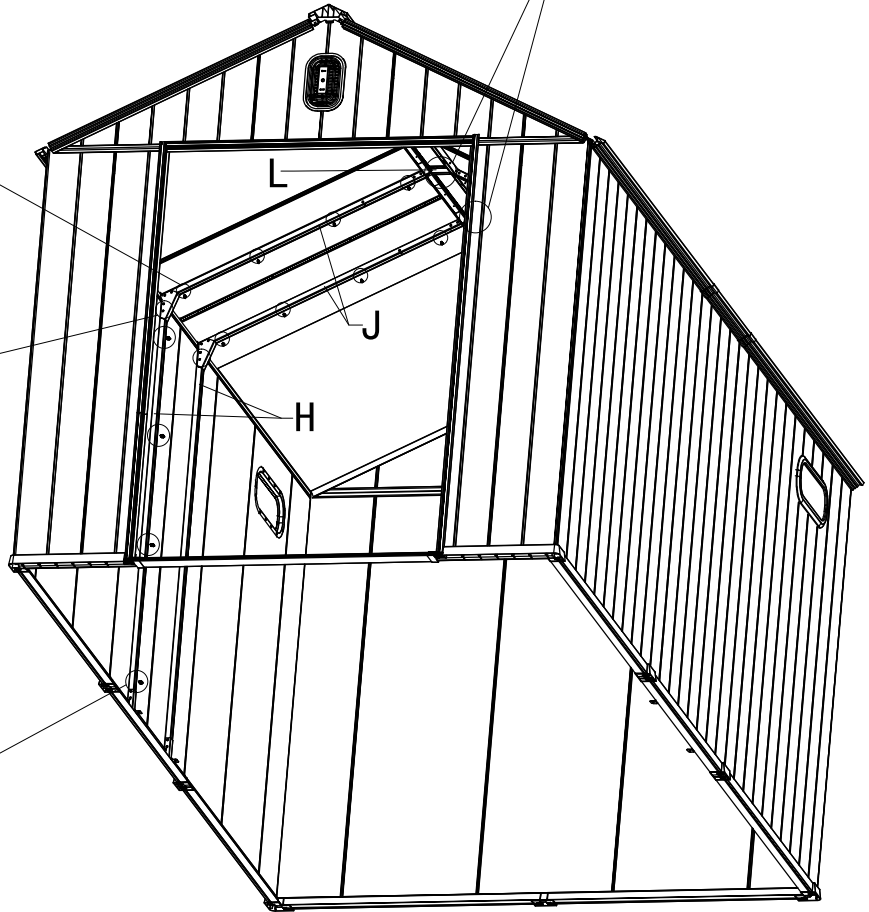
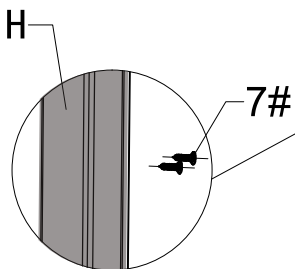

①: Secure #L and roof cover #F with 8 screws 7#,

Secure bracket #J2 and #L with 1 bolts 2#.

②: Secure roof support tube #J to roof supporting bar #G3 with 4 screws 7#.

Repeat the above steps to assemble the other side.

③: Secure bracket #K and support pole #H with 2 bolts 2# and nuts.

Repeat the above steps to assemble the other side.

④: Secure support pole #H to wall panel with 8 screws 7#.

Repeat the above steps to assemble the other side.

**Note: Support tubes must be installed on the 4 #G3s on both sides, while NO support tubes are required for the #G3 in the MIDDLE.**



J1 — x2

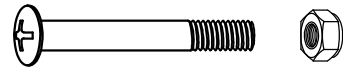

3# - x4

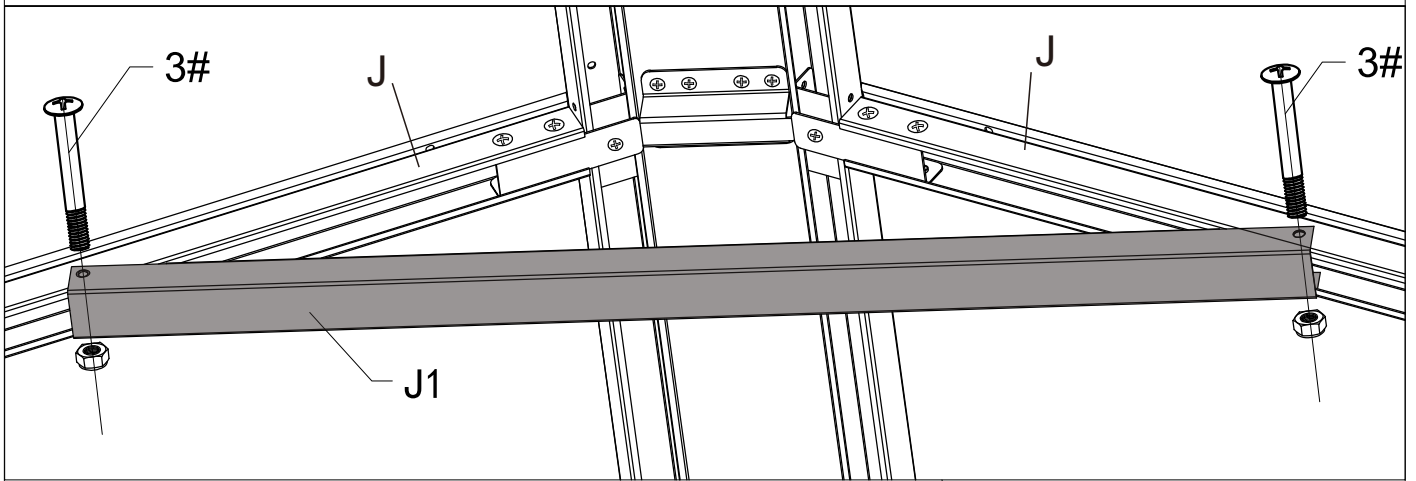

BOTTOM VIEW

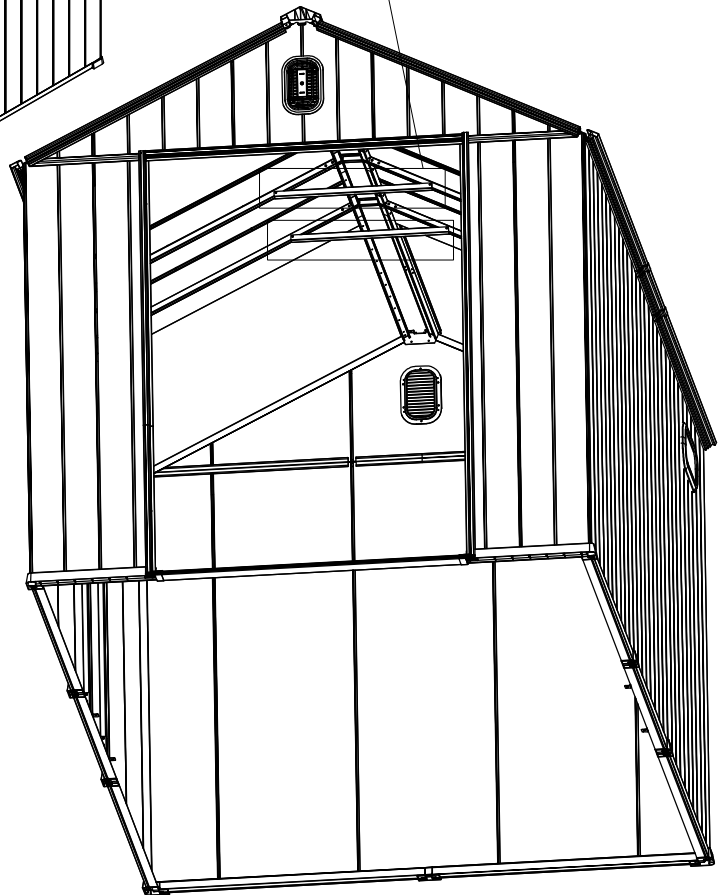
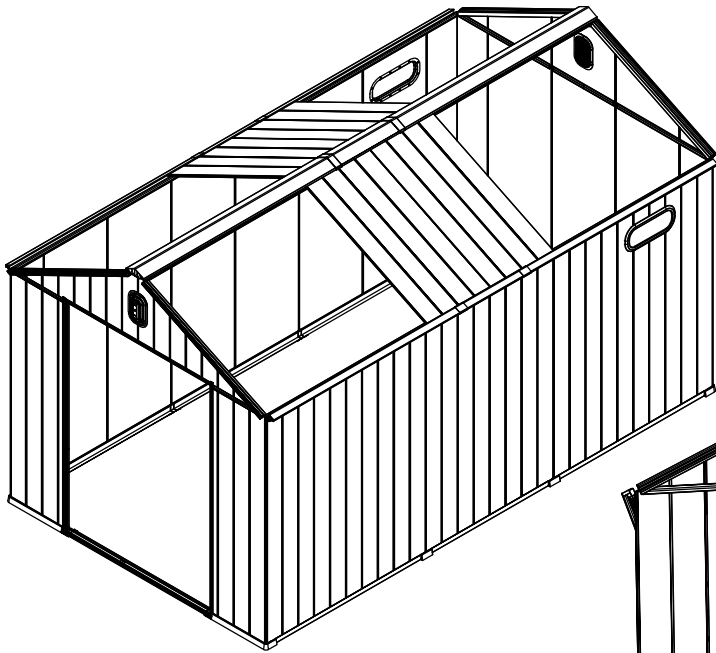

Secure #J and #J1 with 2 bolts and nuts 3#.

Repeat the above steps to assemble another side.

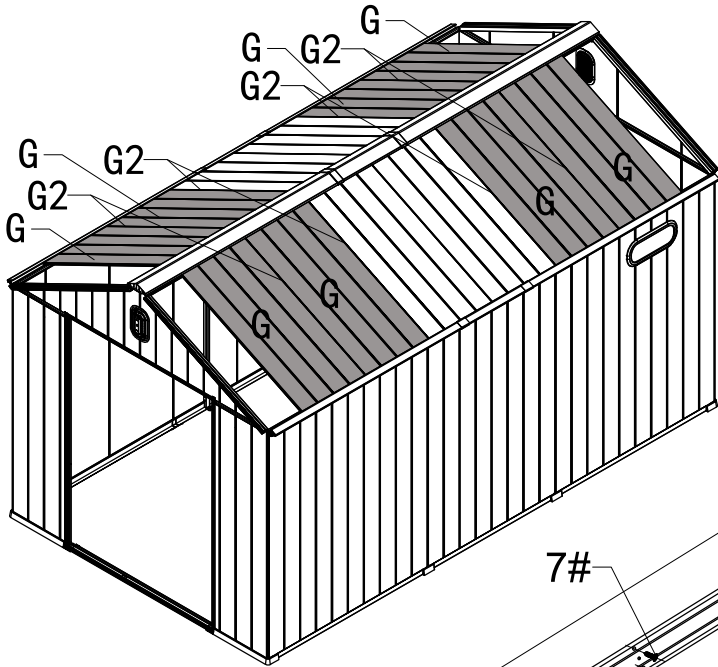
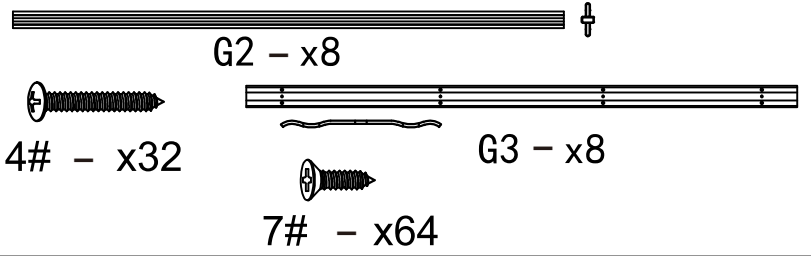
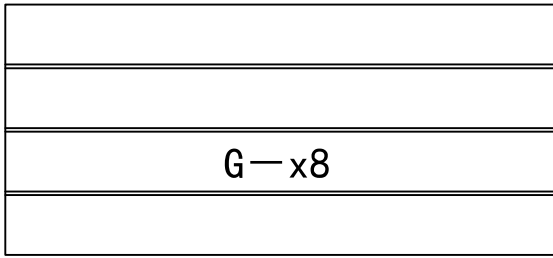

Assemble 4 roof panels #G and 4 roof supporting bars #G3 (at the splicing of each roof panel #G from inside)  
Repeat the above steps to assemble the other side.

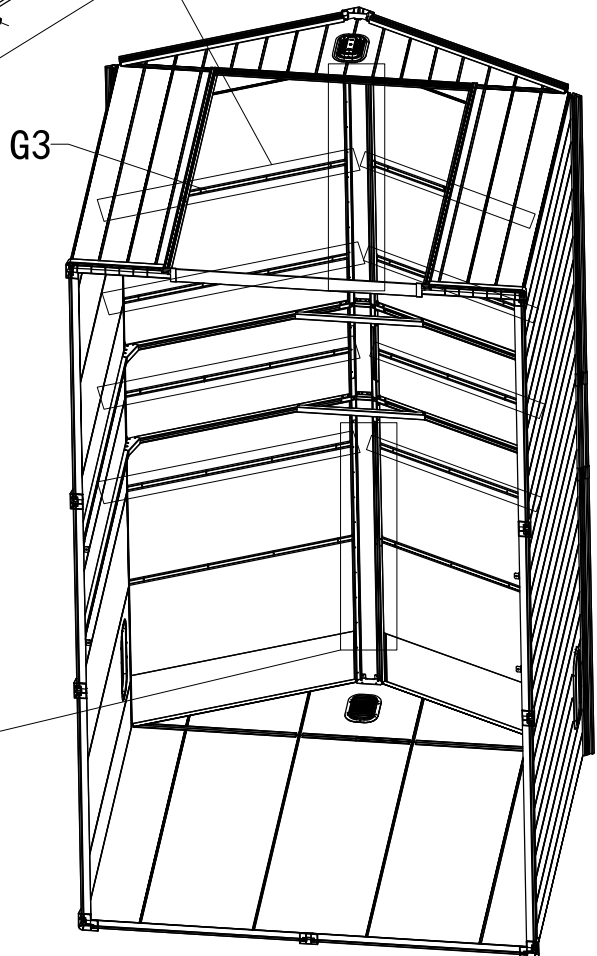
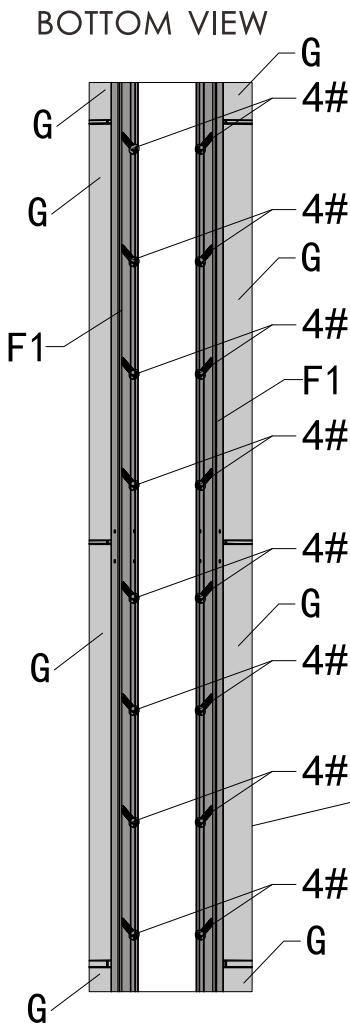
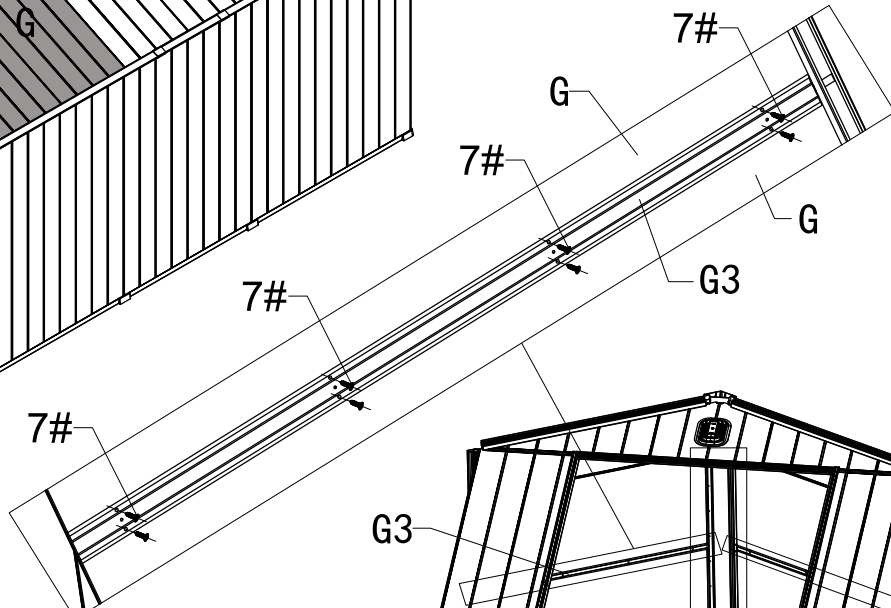



L - x2



3# - x8



7# - x64

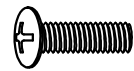

2# - x4

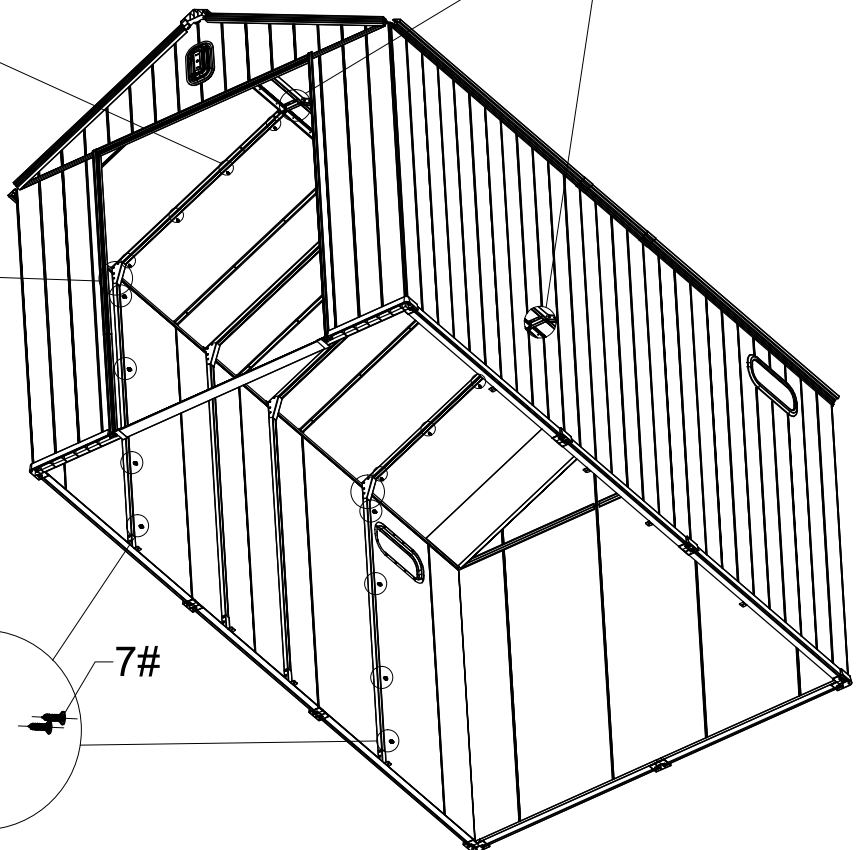
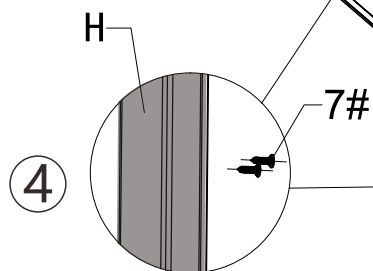
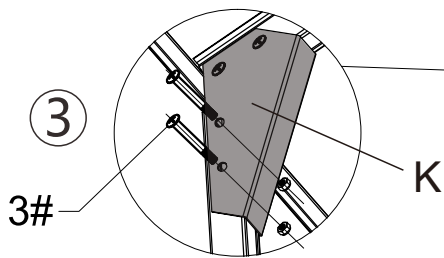
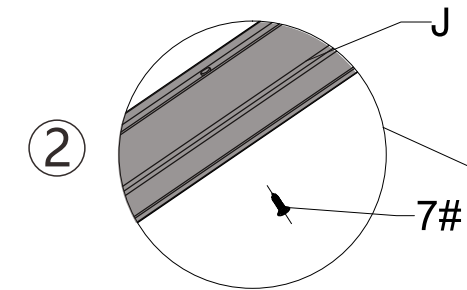
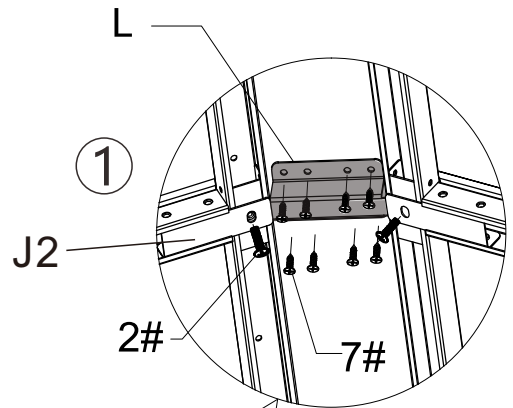
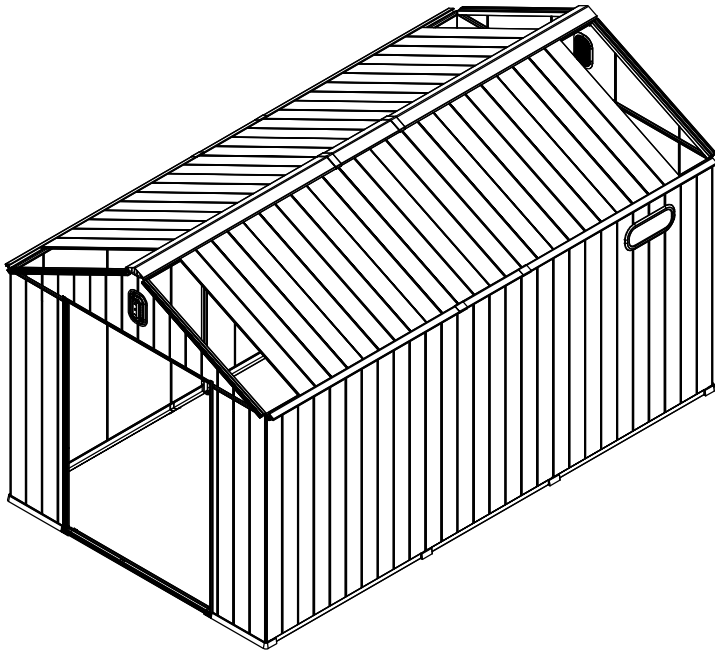

①: Secure #L and roof cover #F with 8 screws 7#,

Secure bracket #J2 and #L with 1 bolts 2#.

②: Secure roof support tube #J to roof supporting bar #G3 with 4 screws 7#.

Repeat the above steps to assemble the other side.

③: Secure bracket #K and support pole #H with 2 bolts 2# and nuts.

Repeat the above steps to assemble the other side.

④: Secure support pole #H to wall panel with 8 screws 7#.

Repeat the above steps to assemble the other side.

**Please install the corresponding fixed support tubes according to the positions marked in the diagram.**



J1 - x2

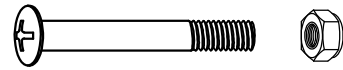

3# - x4

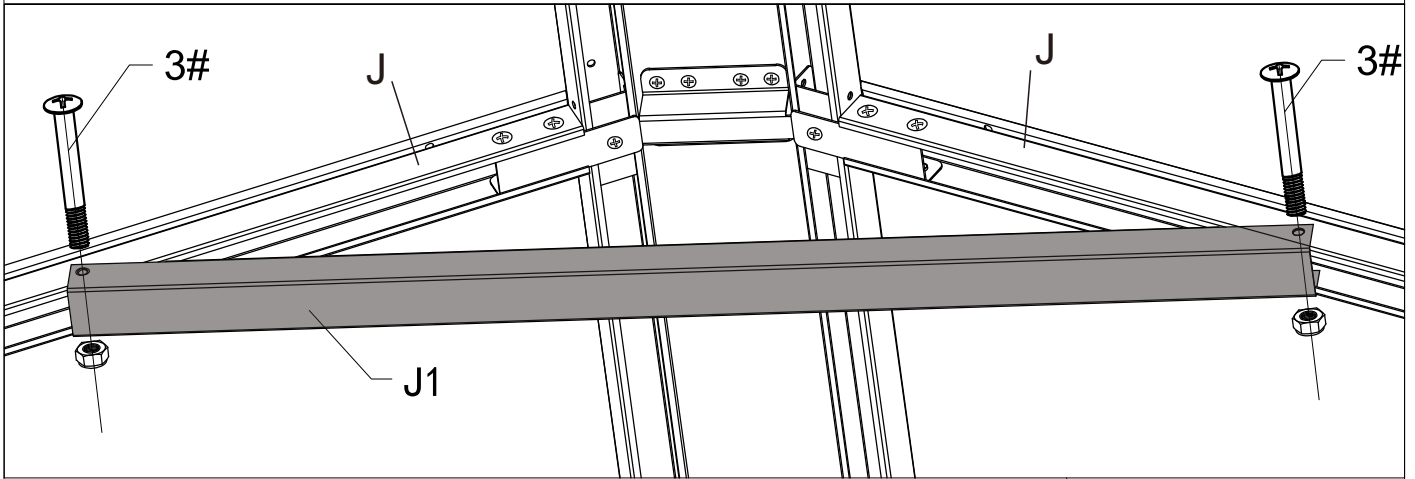

Secure #J and #J1 with 2 bolts and nuts 3#.  
Repeat the above steps to assemble the  
other side.

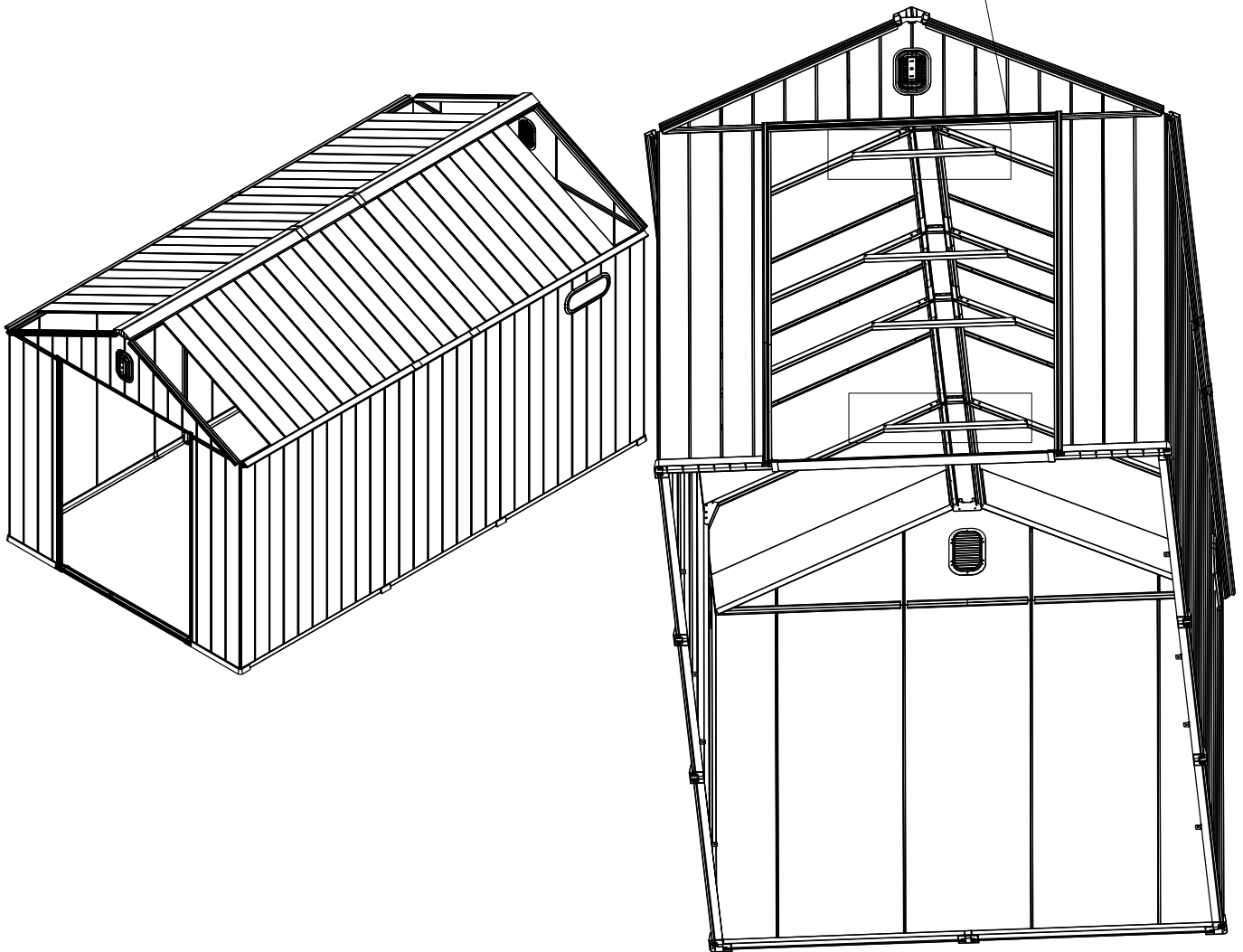

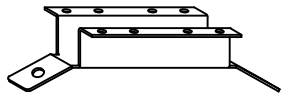

L-x2



3# - x8



7# - x64

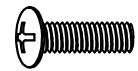

2# - x4

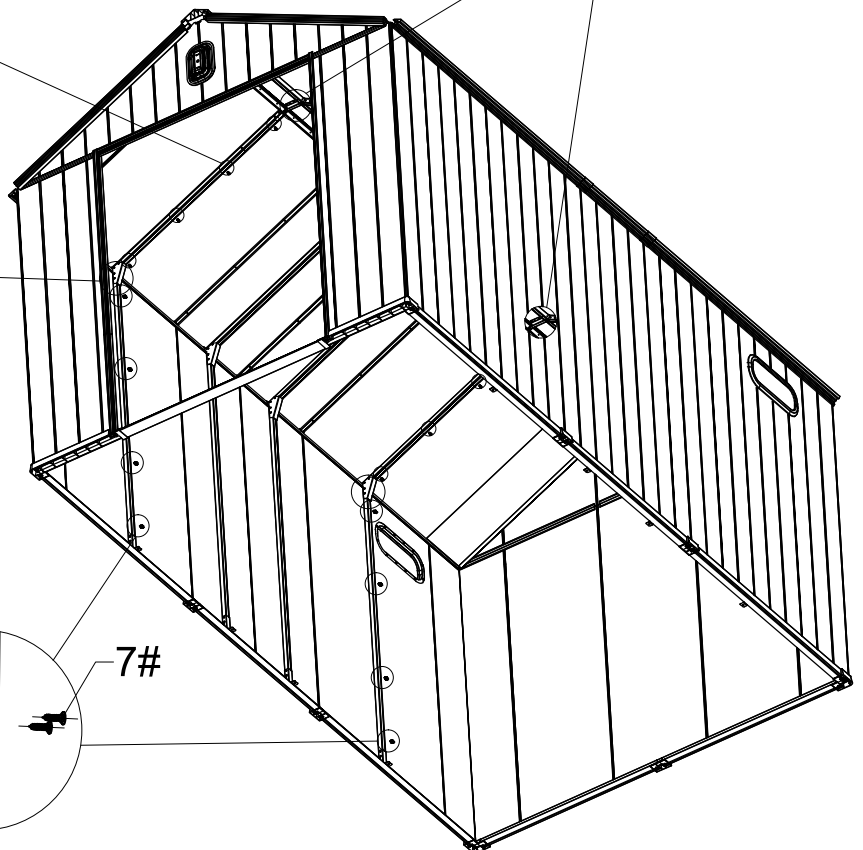
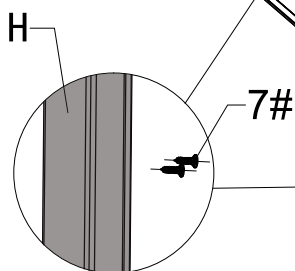
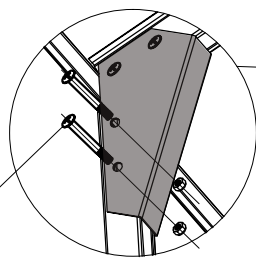
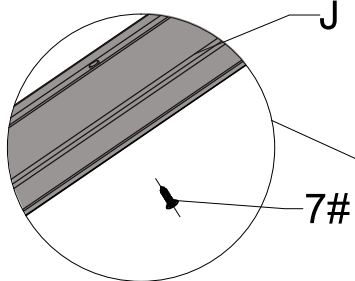
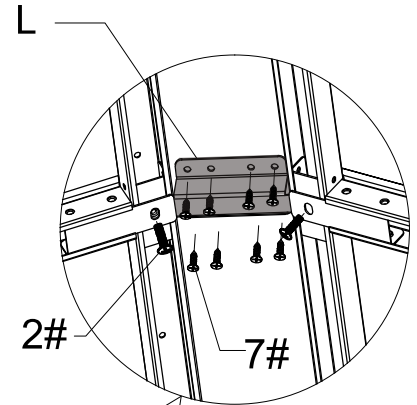
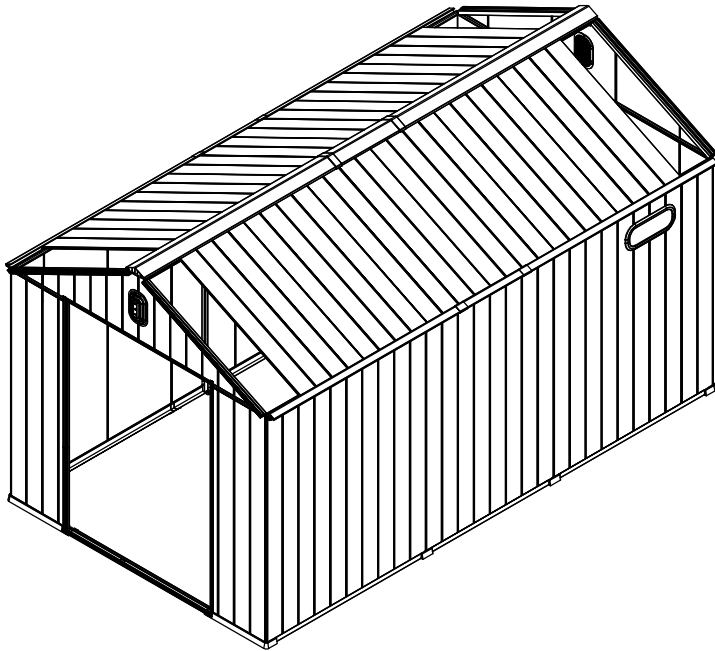

①: Secure #L and roof cover #F with 8 screws 7#,

Secure bracket #J2 and #L with 1 bolts 2#.

②: Secure roof support tube #J to roof supporting bar #G3 with 4 screws 7#.

Repeat the above steps to assemble the other side.

③: Secure bracket #K and support pole #H with 2 bolts 2# and nuts.

Repeat the above steps to assemble the other side.

④: Secure support pole #H to wall panel with 8 screws 7#.

Repeat the above steps to assemble the other side.

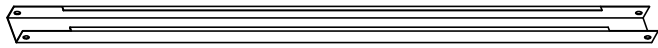

J1 - x2

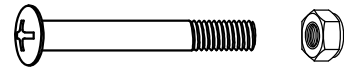

3# - x4

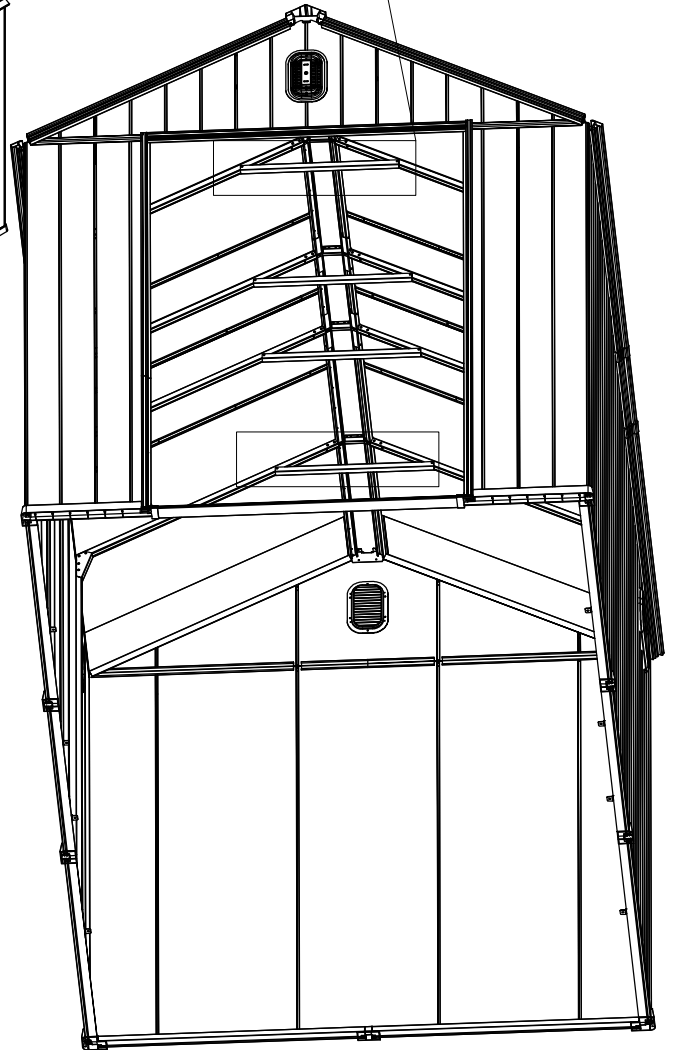
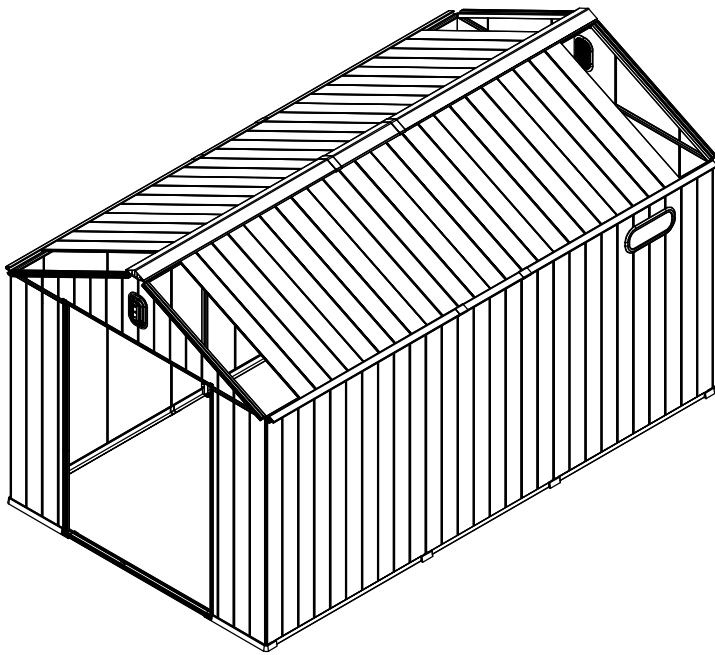
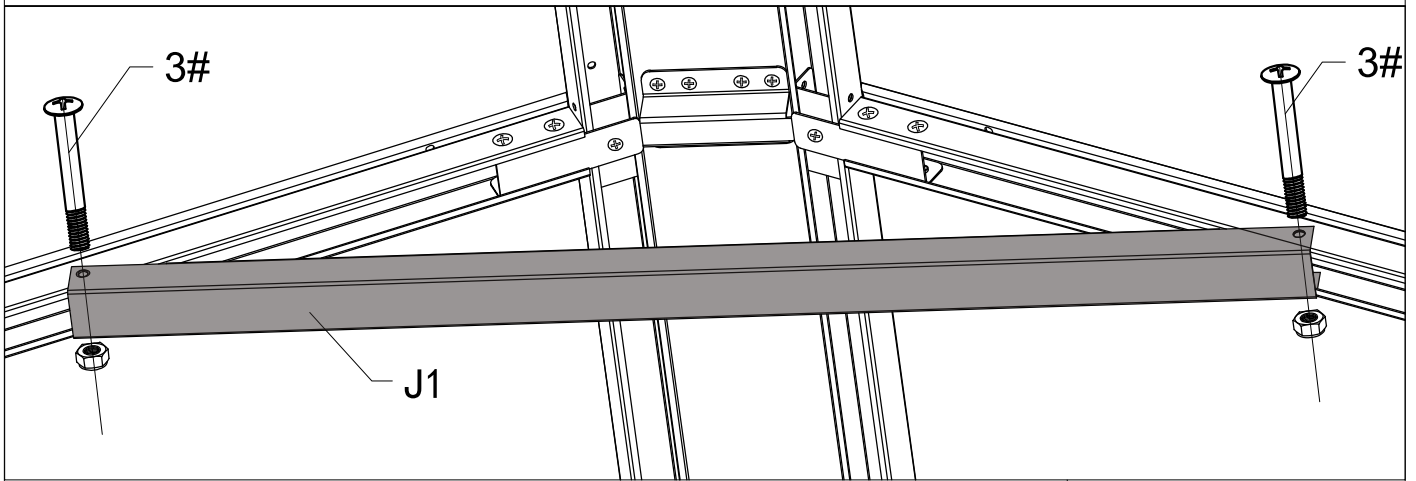

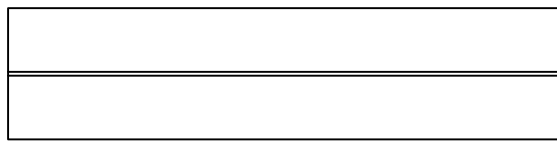

G1 - x4

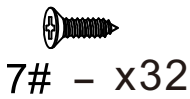

7# - x32



G2 - x4

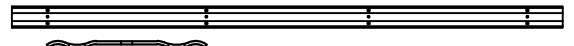

G3 - x4

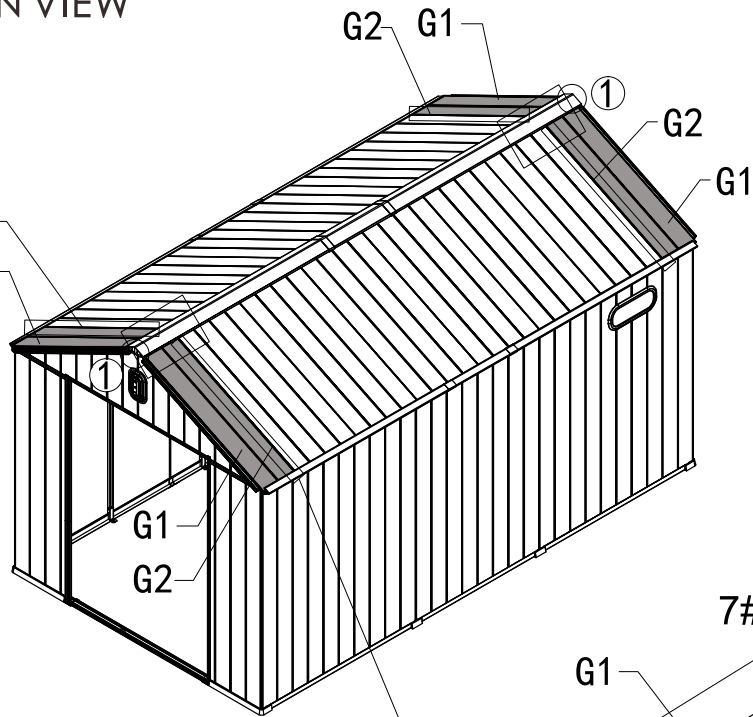
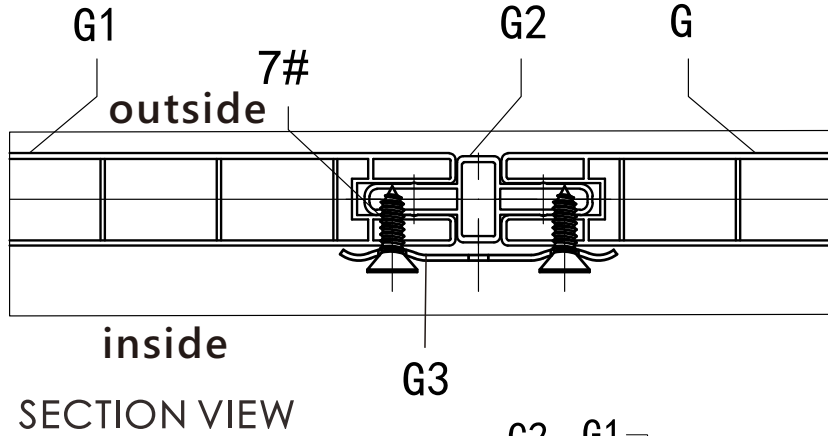

Assemble 4 roof panels #G1 and 4 roof supporting bars #G3(at the splicing of each roof panel #G1 from inside) Repeat the above steps to assemble the other side.

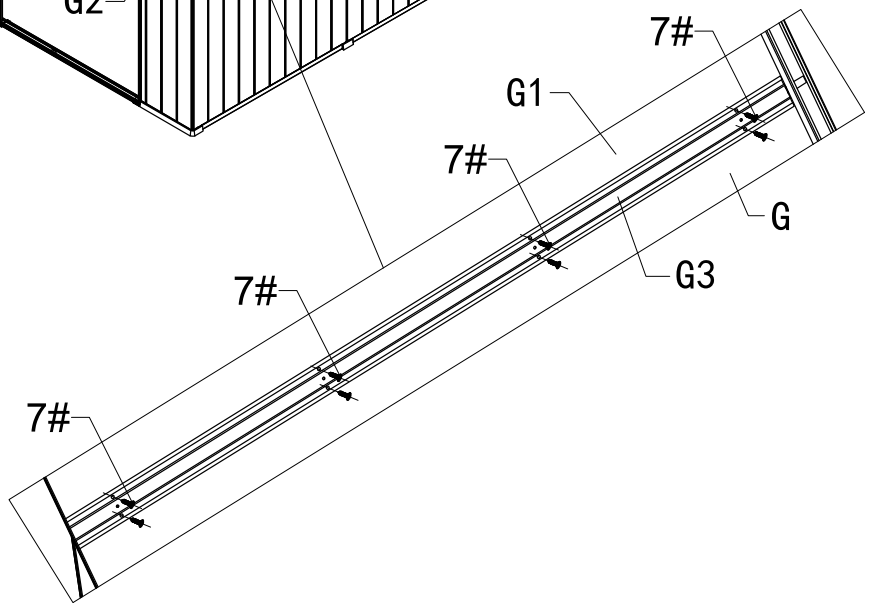

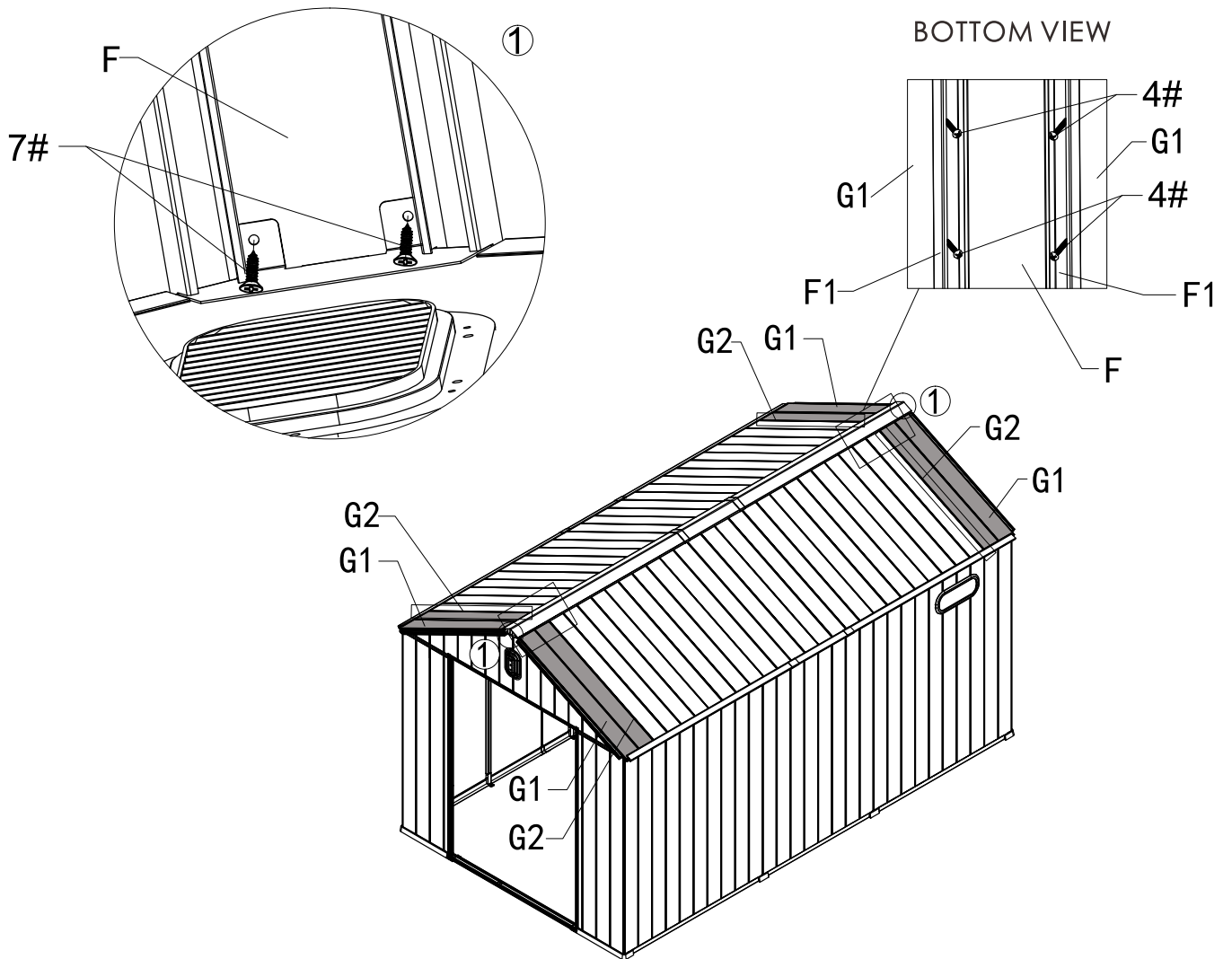
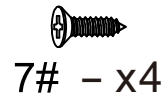
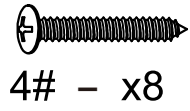

Secure the roof panel #G1 with roof cover #F.



F3—x4



6# — x12

Secure #F3 and #G1 with 3 screws 6#.

Repeat above steps to assemble remained parts.

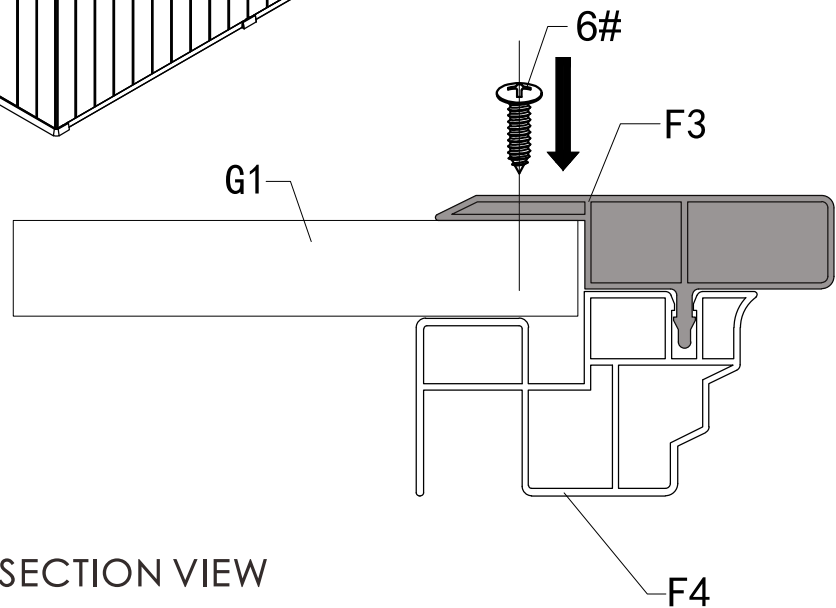
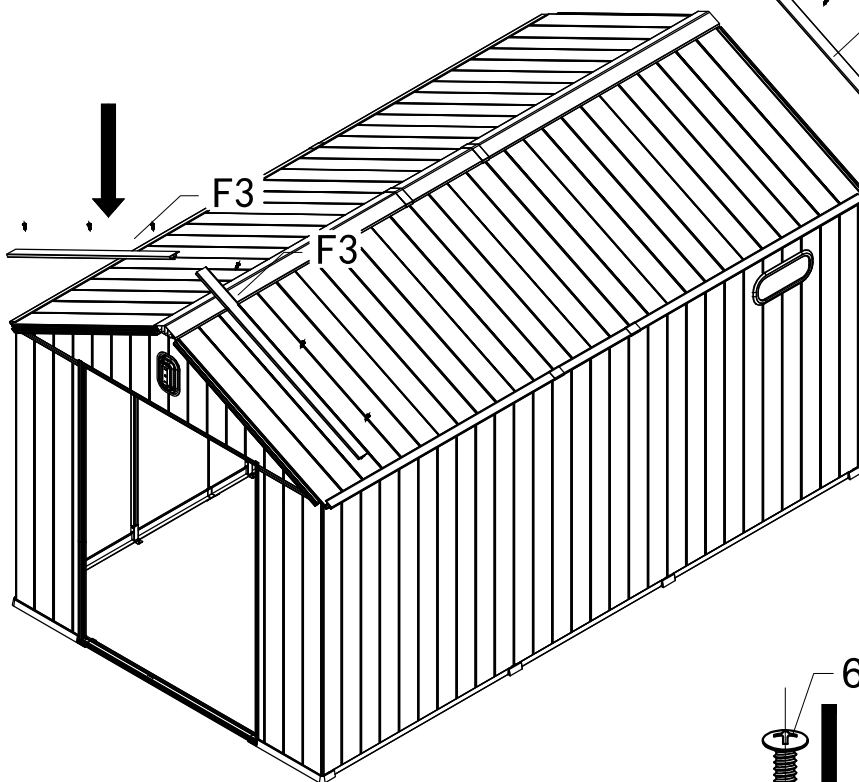
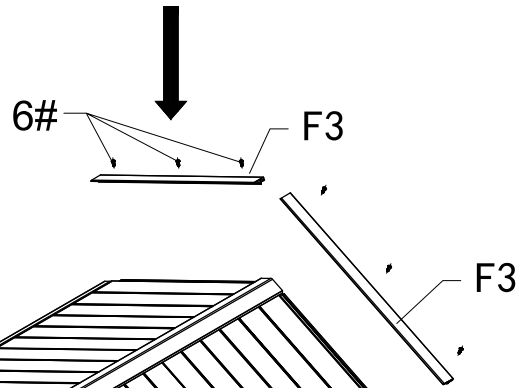

SECTION VIEW



6# — x20

Secure 4 #F4 to wall panel with 5 screws 6# (from inside).  
Repeat above steps to assemble the other 3 sides.

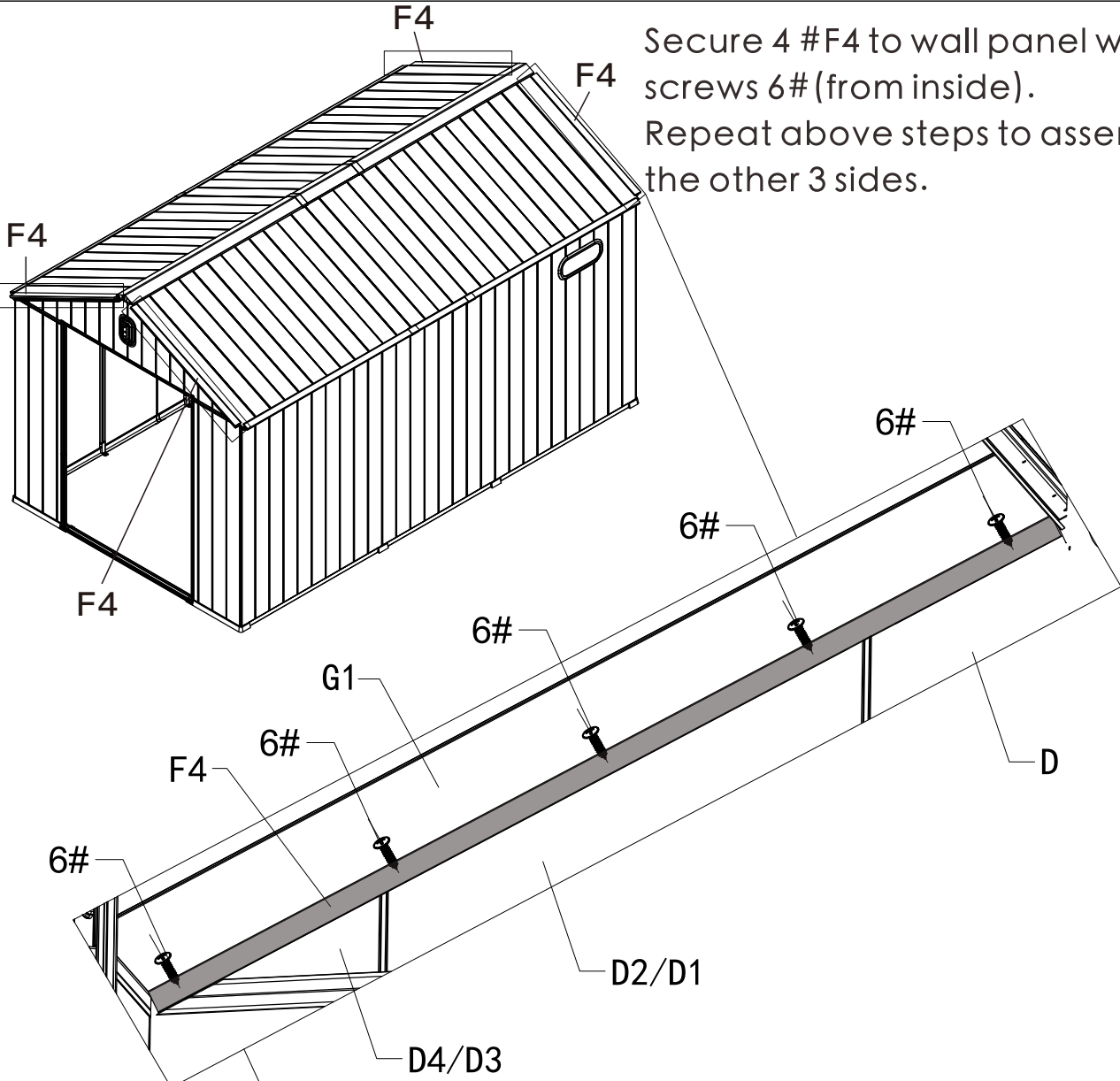

INSIDE VIEW

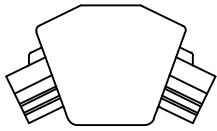

GJF001-x2

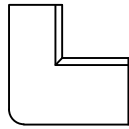

GJF002-x2

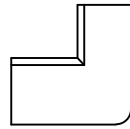

GJF003-x2



6# - x16

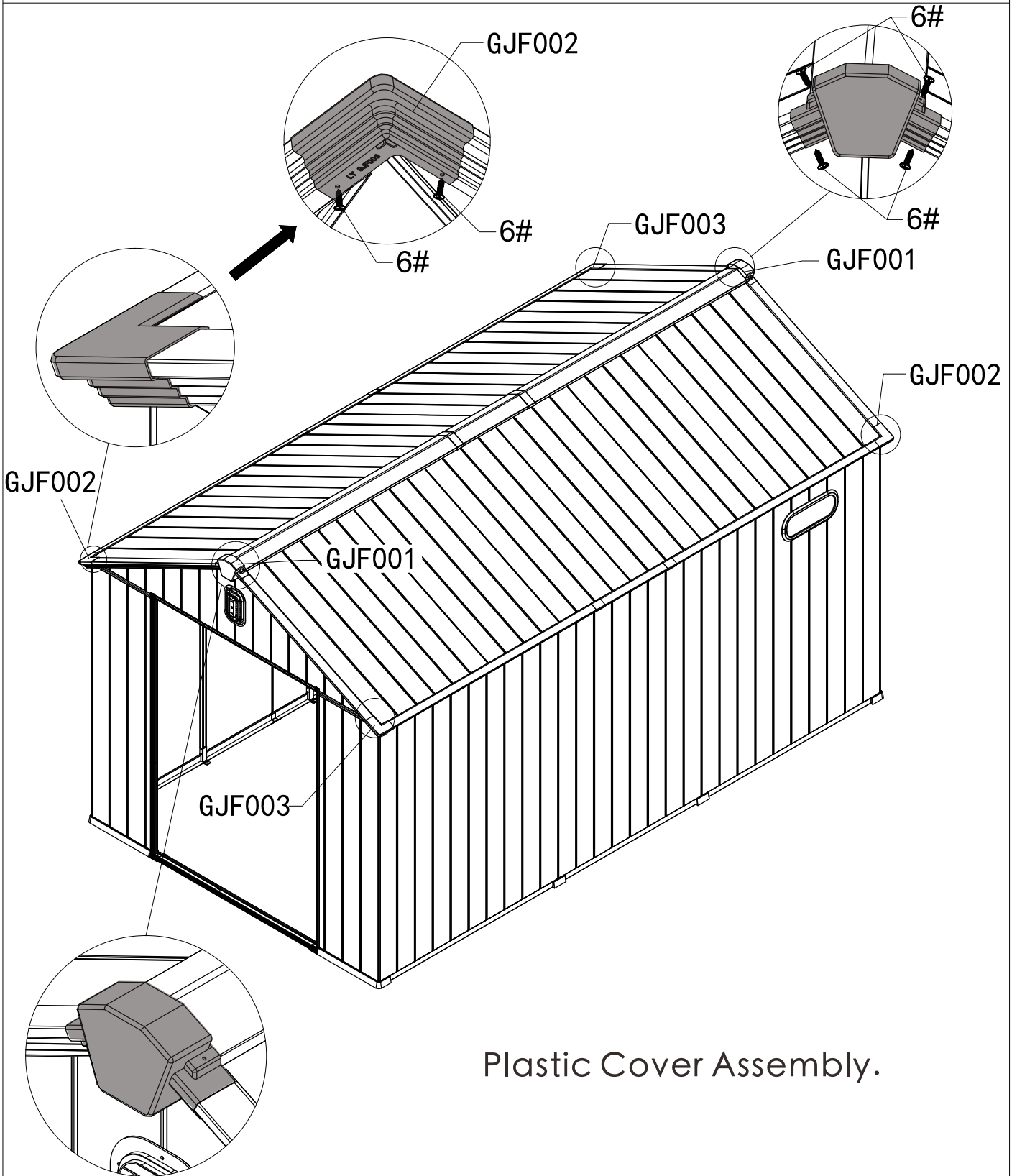

Plastic Cover Assembly.



6# - x32

Secure Wall Panels and #F2/F2a with 16 screws 6#(from inside). Repeat the above steps to assemble the another side.

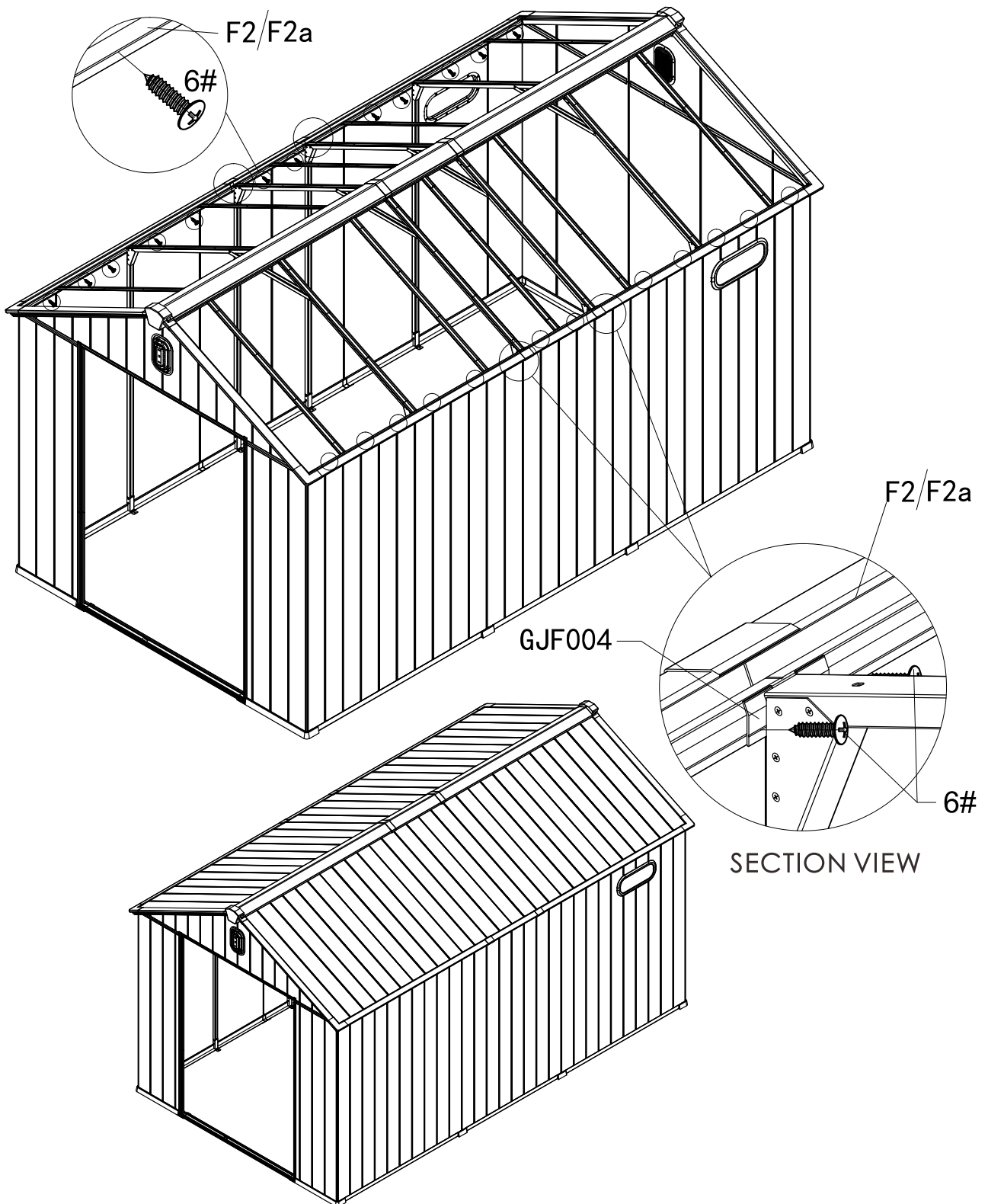

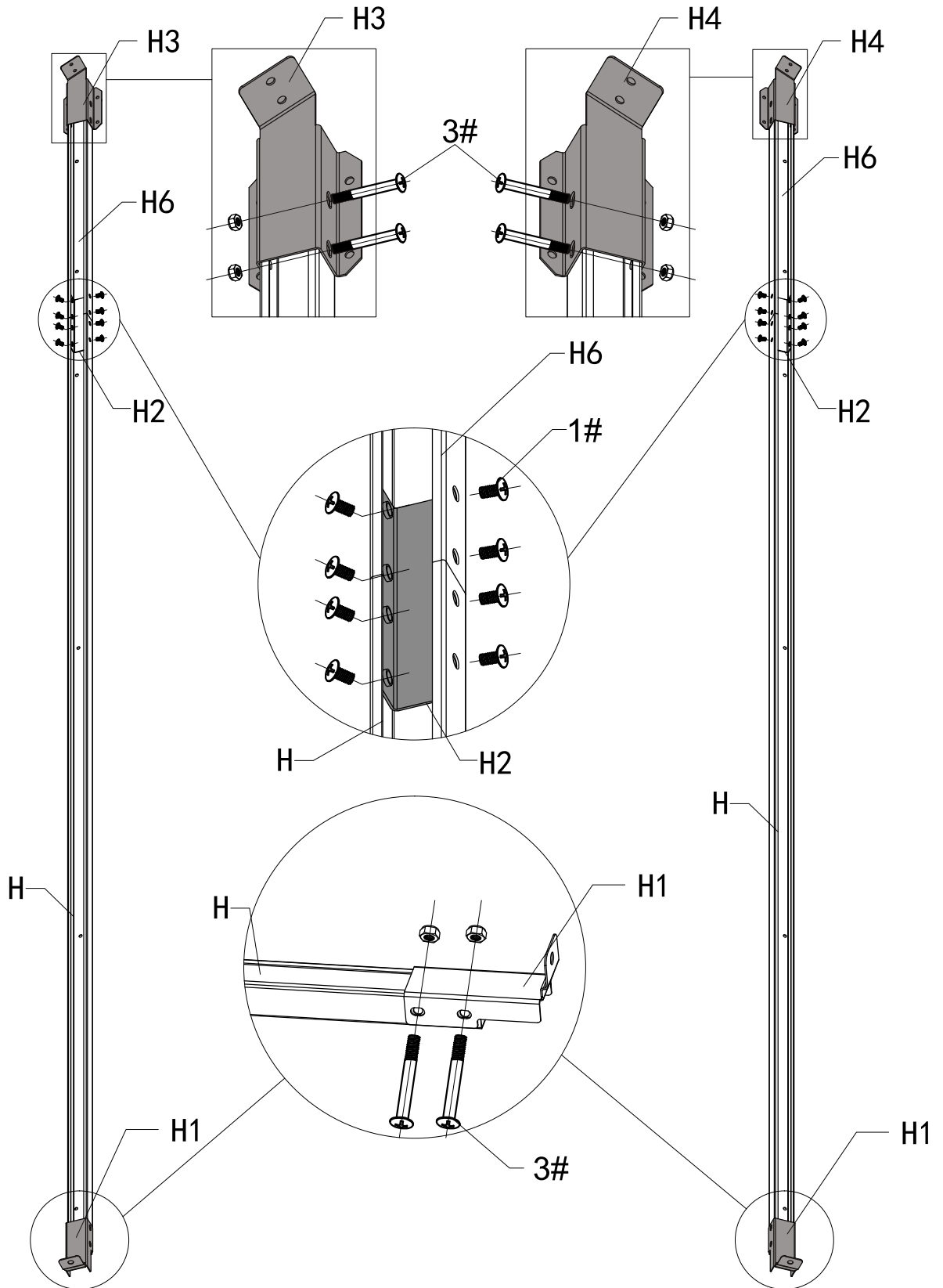
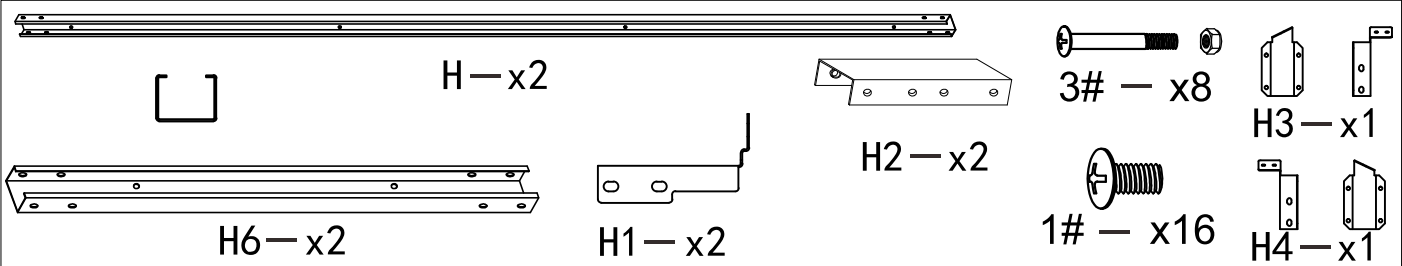

Rear Supporting Pole Assembly



7# - x24



6# - x12

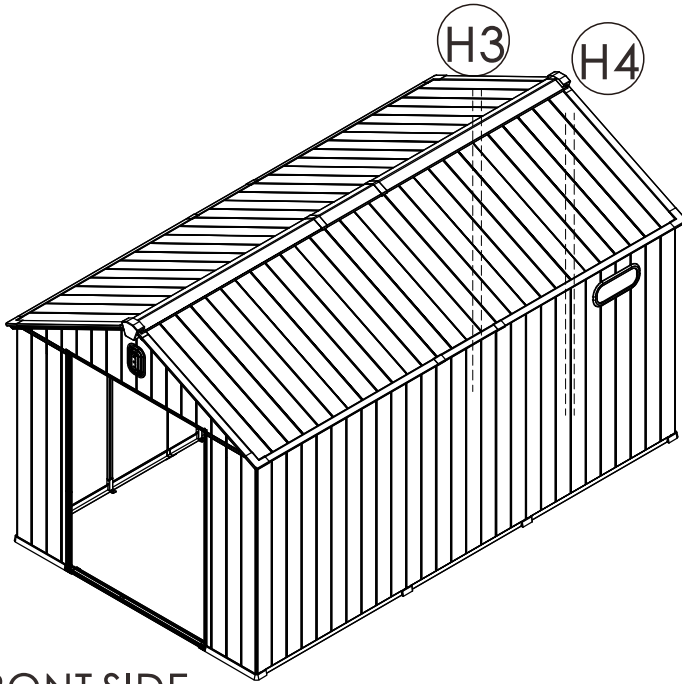

FRONT SIDE

Use 6 screws 6# to Secure bracket #H3/#H4 to roof panels(2 screws) and wall panels(4 screws).

Use 12 screws 7# to Secure supporting pole #H to wall panels.

Repeat above process to assemble the other part.

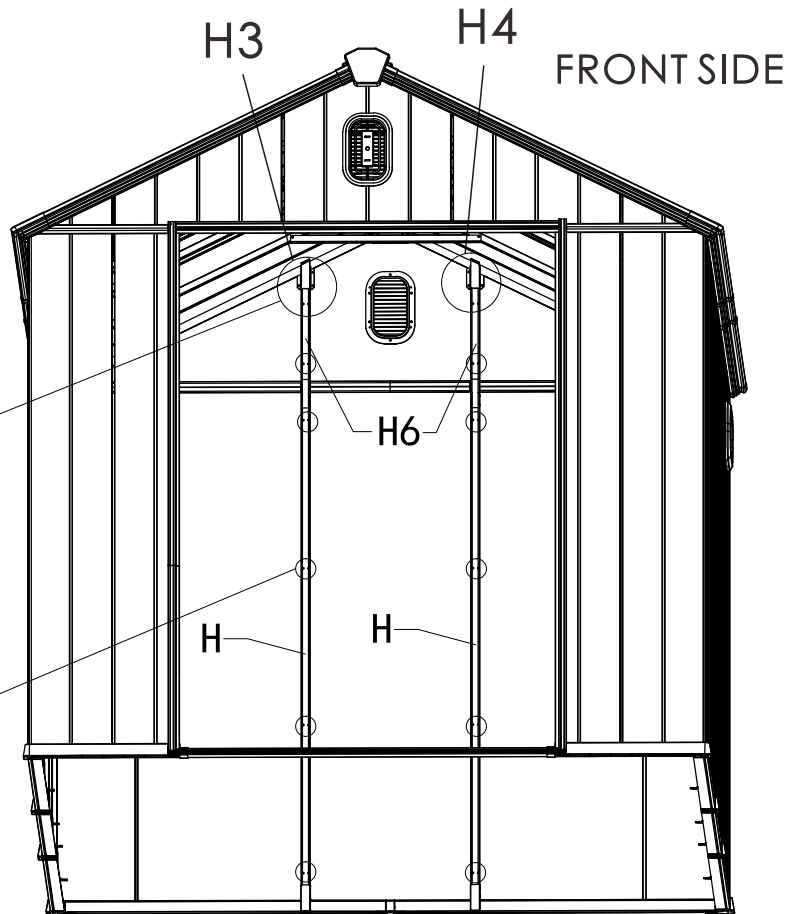

BACK SIDE

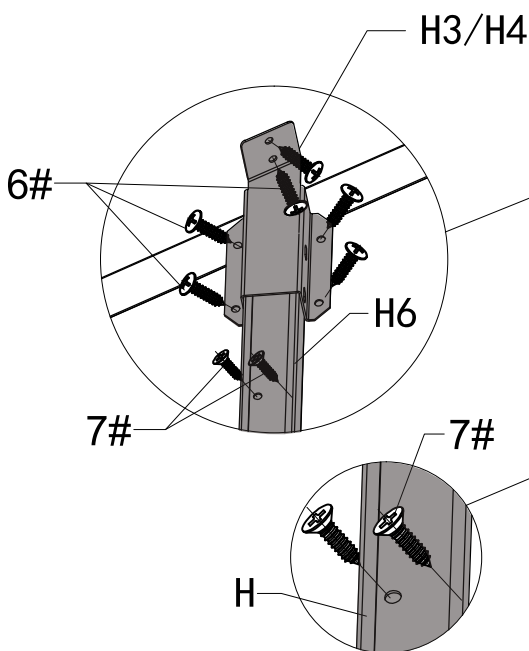

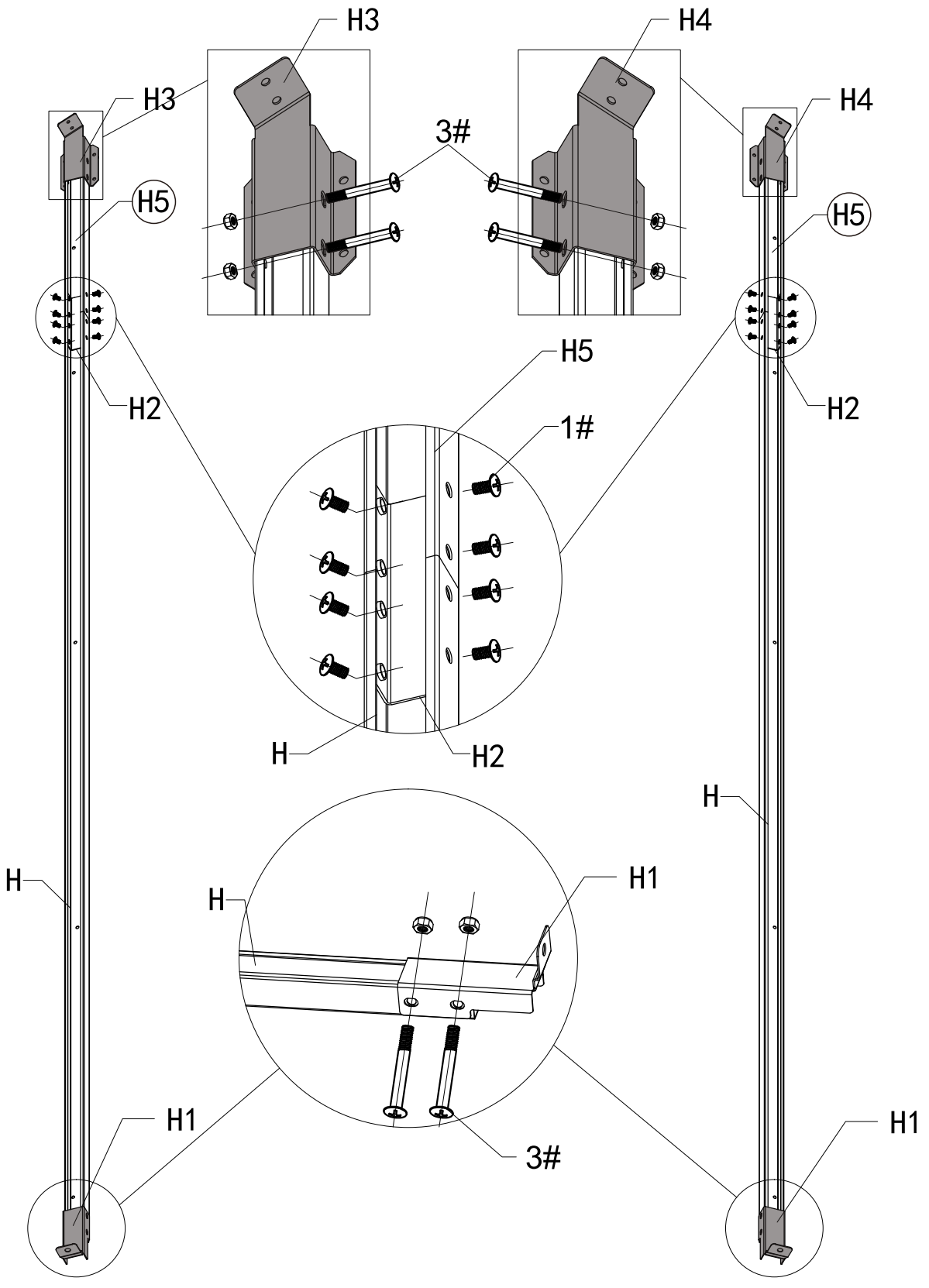
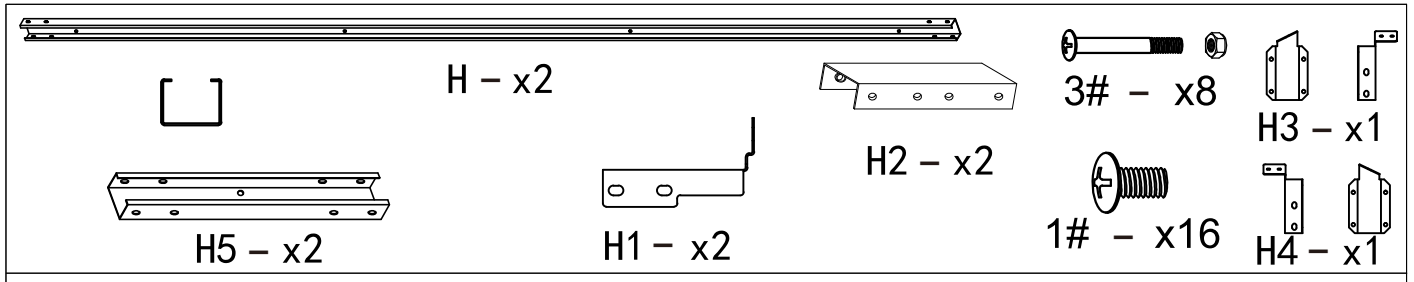



7# - x20



6# - x12

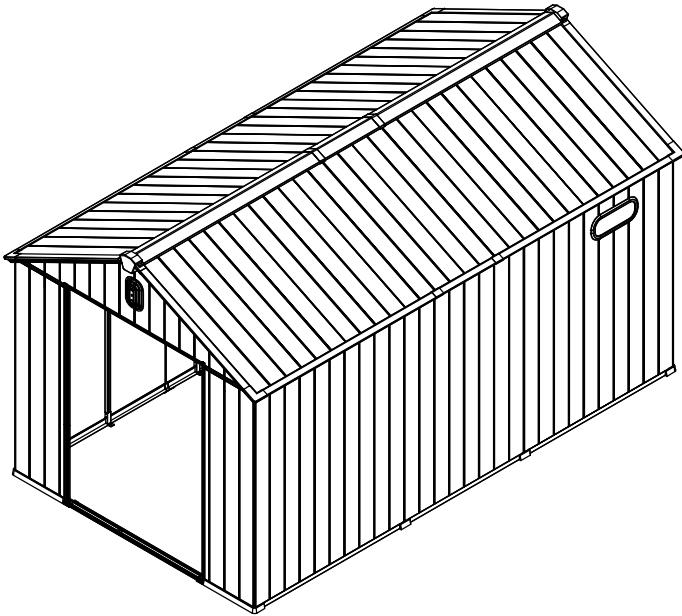

Use 6 screws 6# to Secure bracket #H3/#H4 to roof panels(2 screws) and wall panels(4 screws).  
Use 10 screws 7# to Secure supporting pole #H to wall panels.  
Repeat above process to assemble the other part.

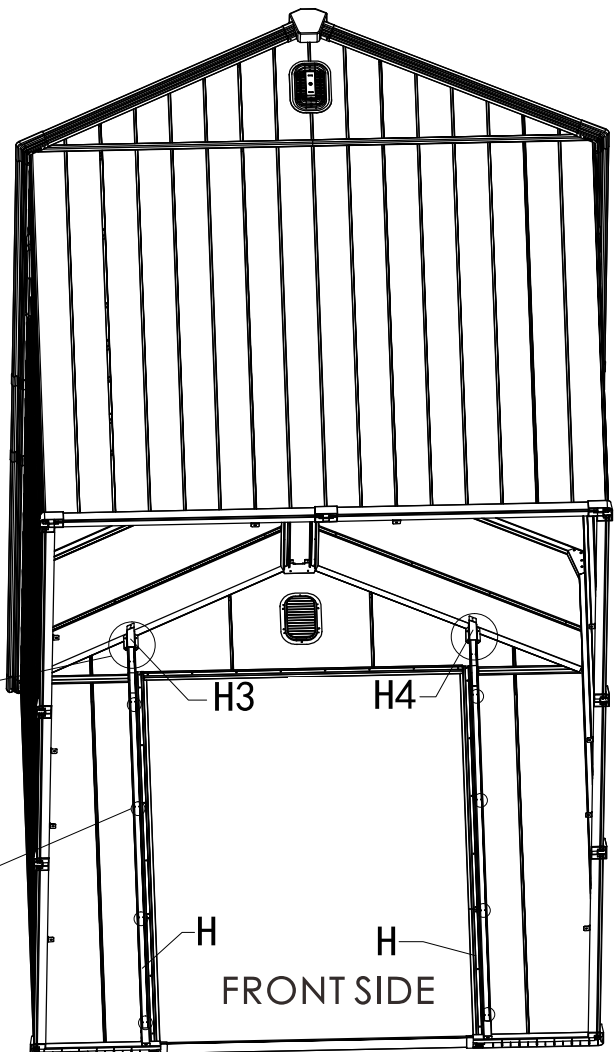
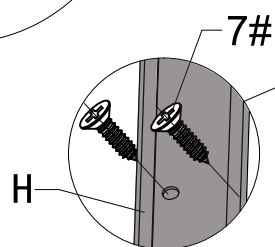
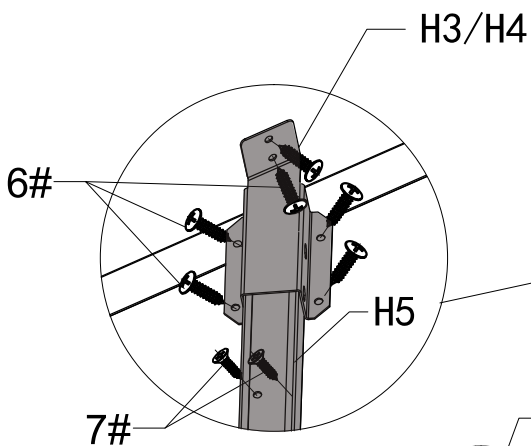

FRONT SIDE

9# — x8

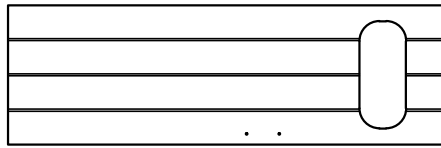

GJF012-x1

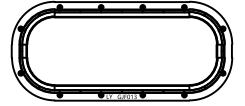

GJF013-x1

10# — x12



R-x1

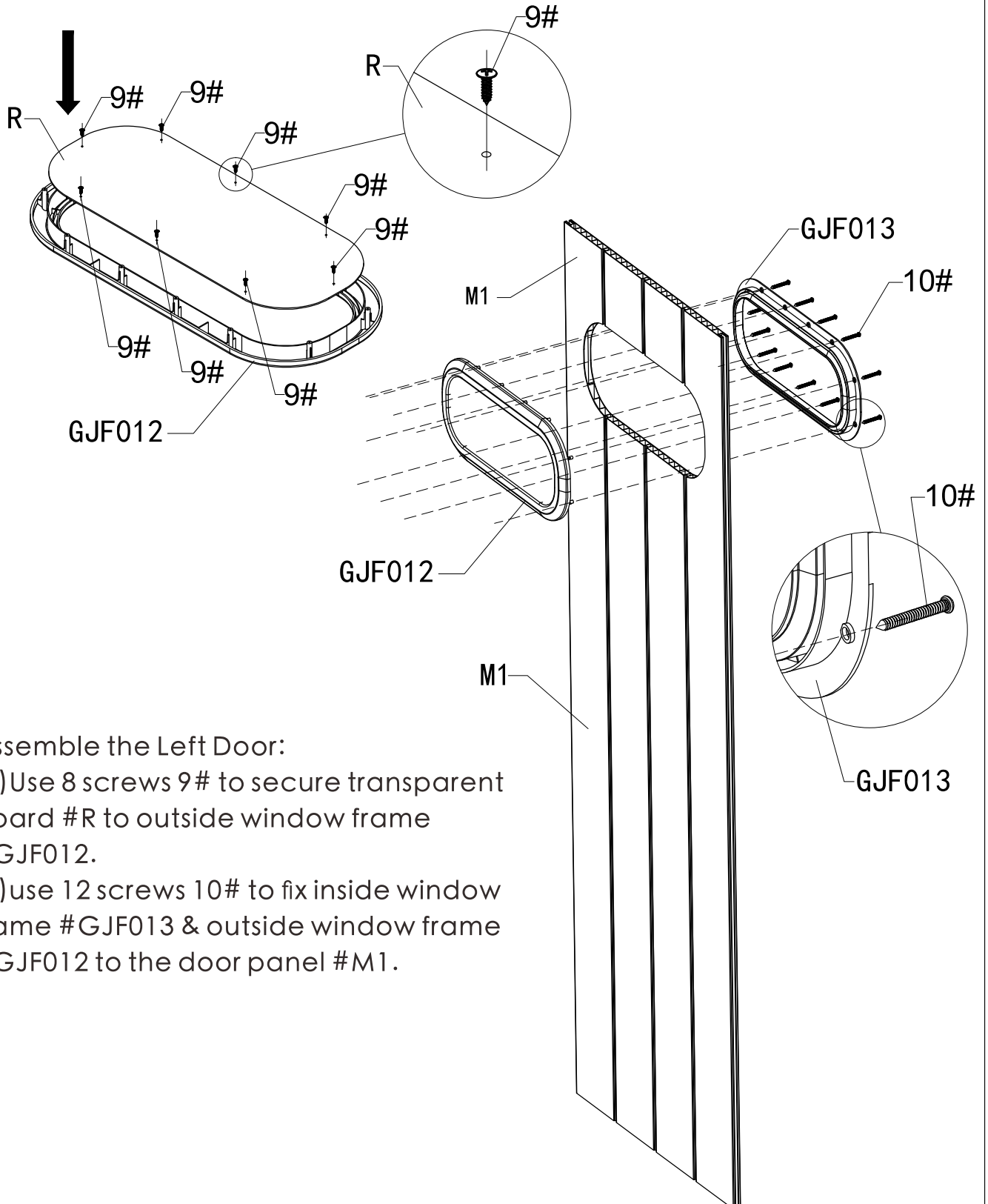

Assemble the Left Door:

- (1) Use 8 screws 9# to secure transparent board #R to outside window frame #GJF012.
- (2) use 12 screws 10# to fix inside window frame #GJF013 & outside window frame #GJF012 to the door panel #M1.

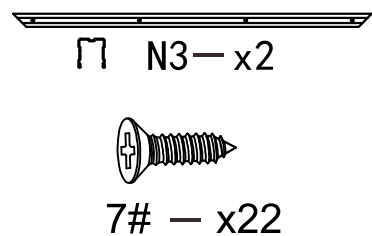
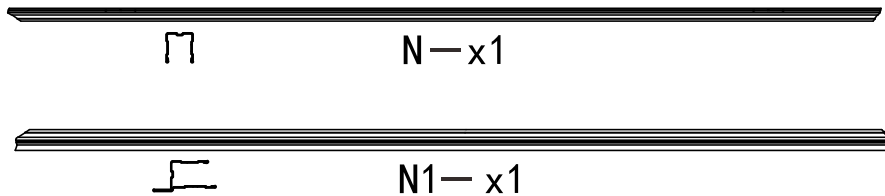

# Door Frame Assembly

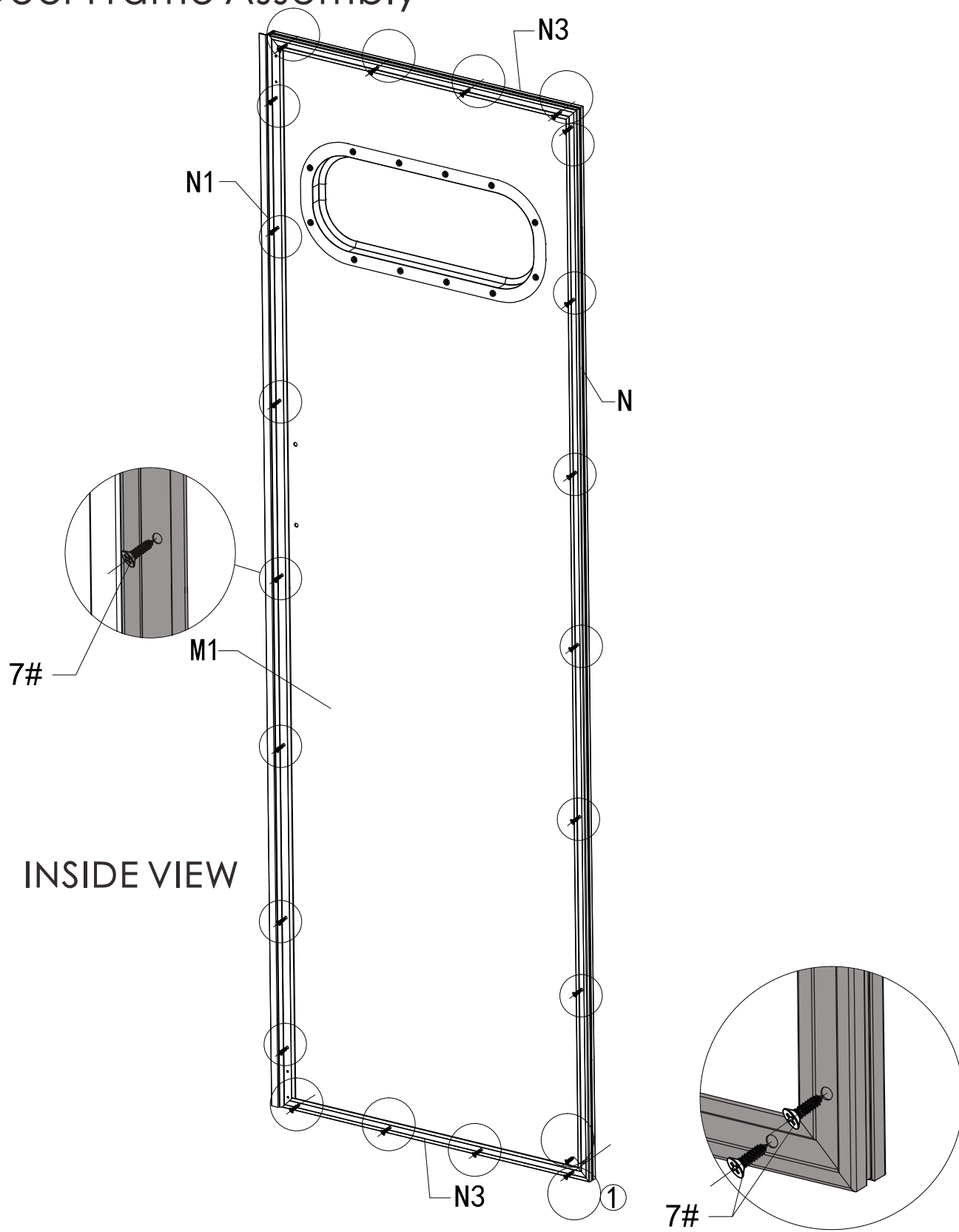

INSIDE VIEW



GJF016-x1

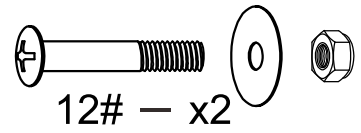

## Doorknob Assembly

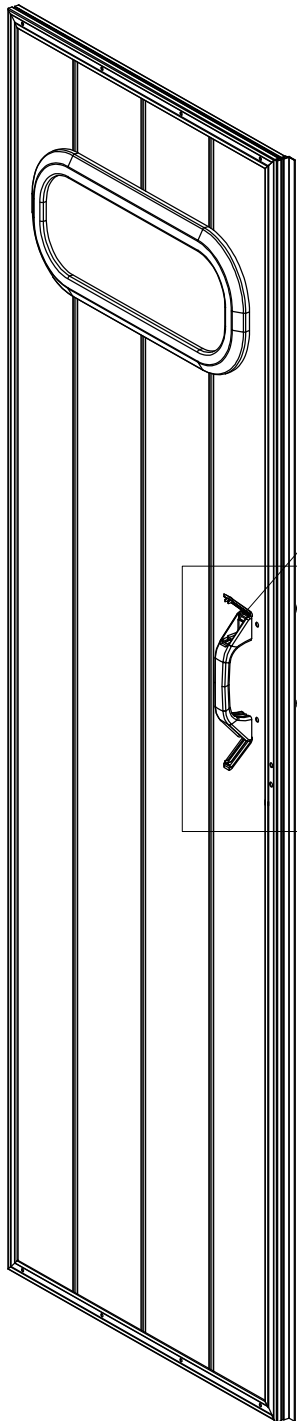

### OUTSIDE VIEW

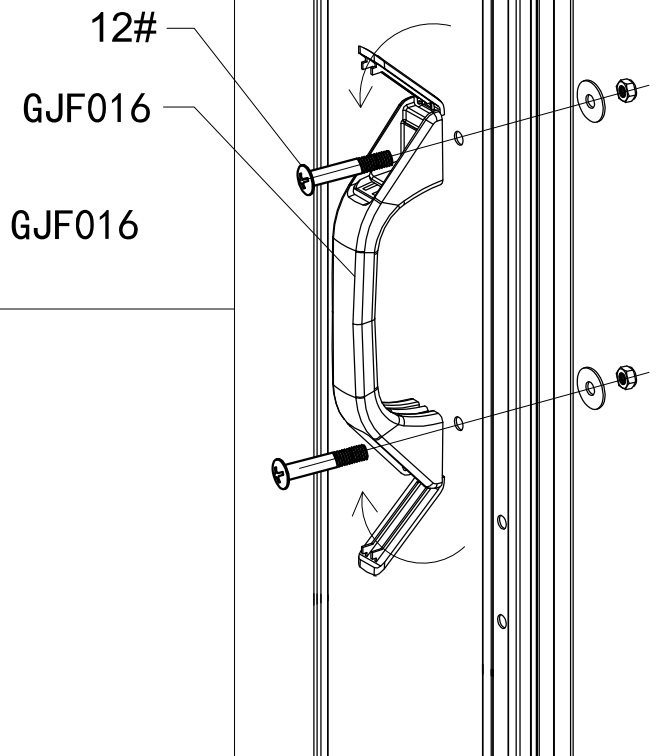

The doorknob has two covers, close the lid is after fixing the screws.

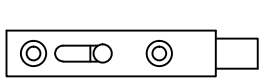

CX—x2



7# — x4



6# — x2

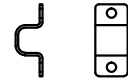

Q1—x1

Install the top and bottom latches and #Q1.

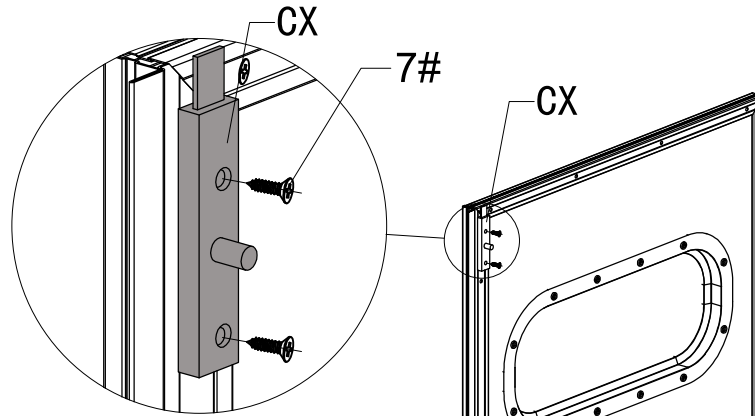

INSIDE VIEW

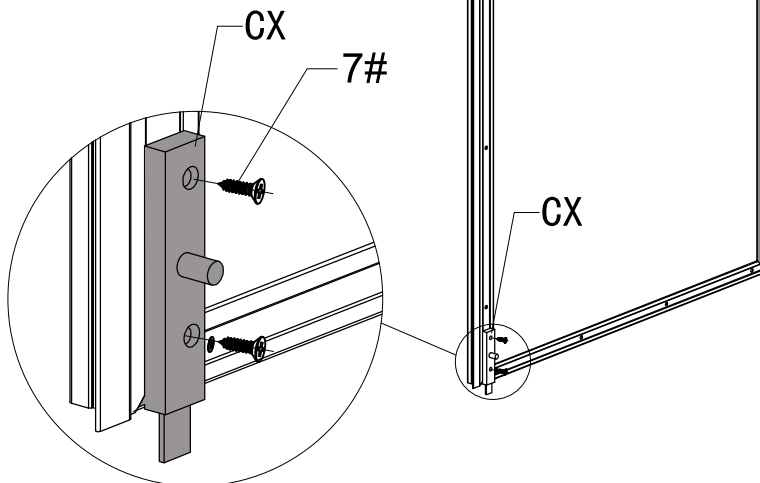
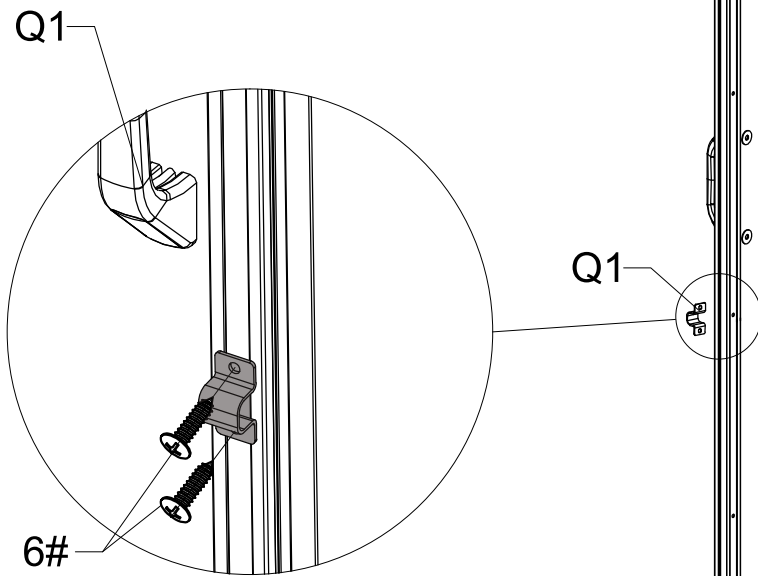

9# — x8

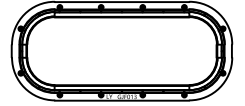
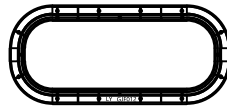
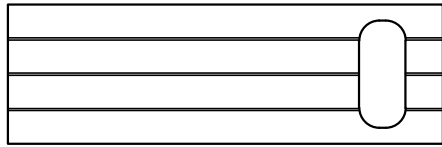

10# — x12

M2 — x1



R — x1

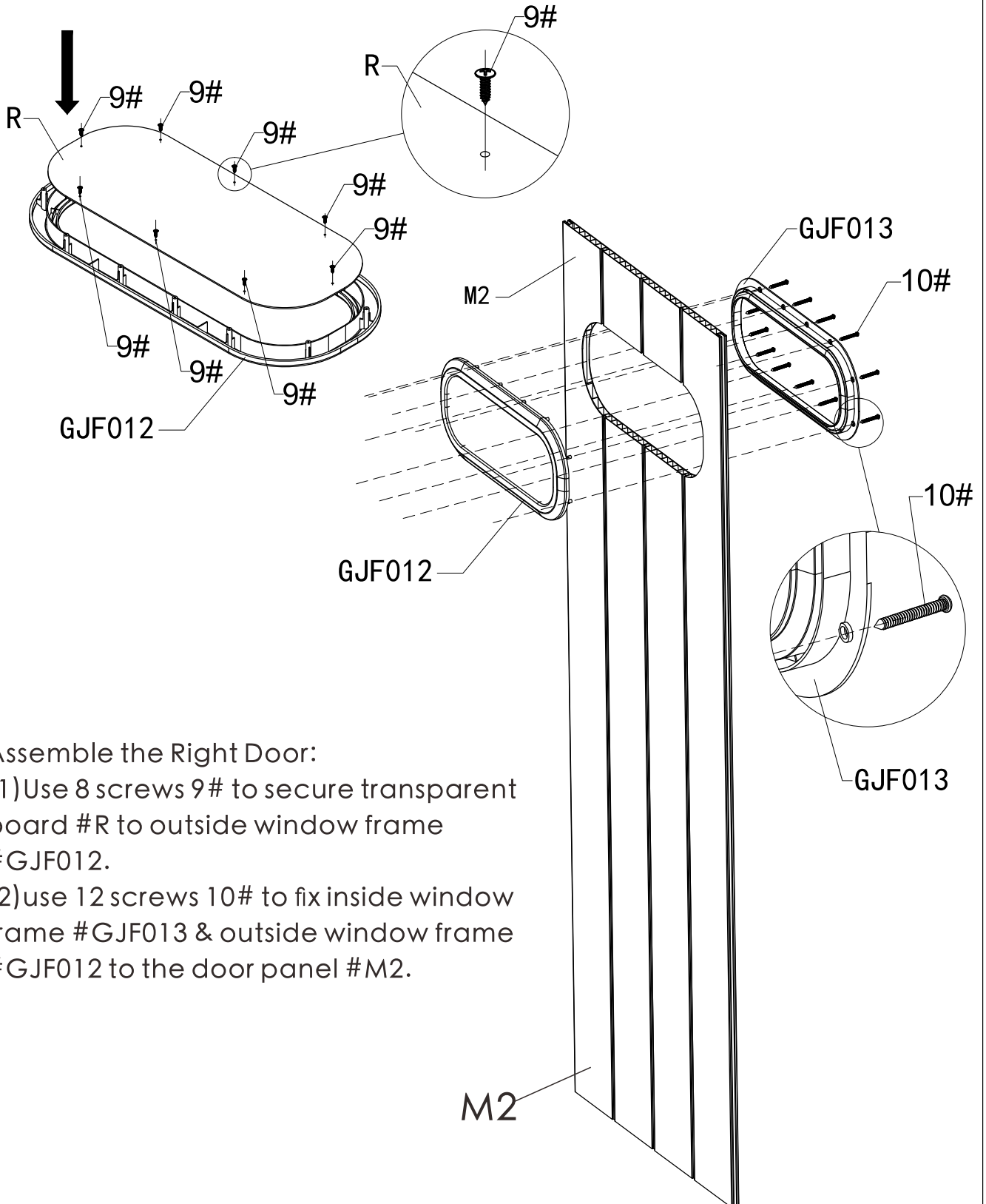

Assemble the Right Door:

(1) Use 8 screws 9# to secure transparent board #R to outside window frame #GJF012.

(2) use 12 screws 10# to fix inside window frame #GJF013 & outside window frame #GJF012 to the door panel #M2.



M3—x1

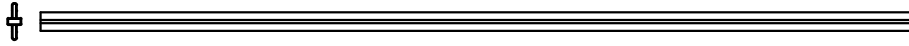

M4—x1

OUTSIDE VIEW

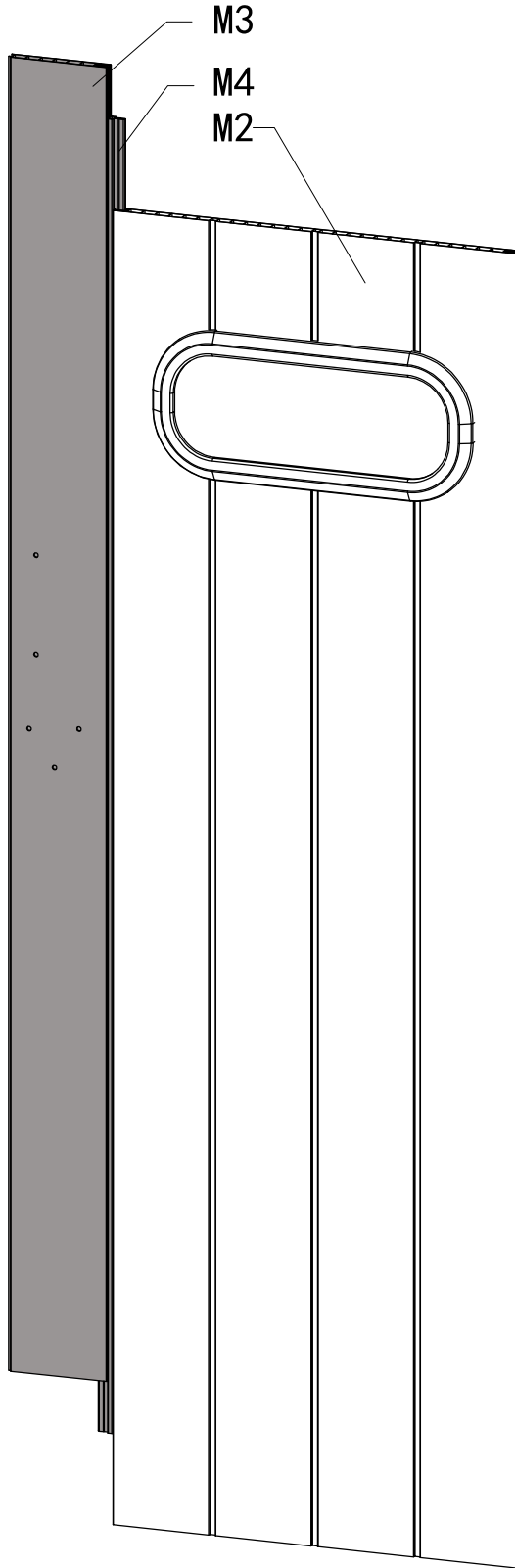



N-x1



N2-x1



7# - x24

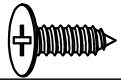

5# - x4



N4-x2

# Door Frame Assembly

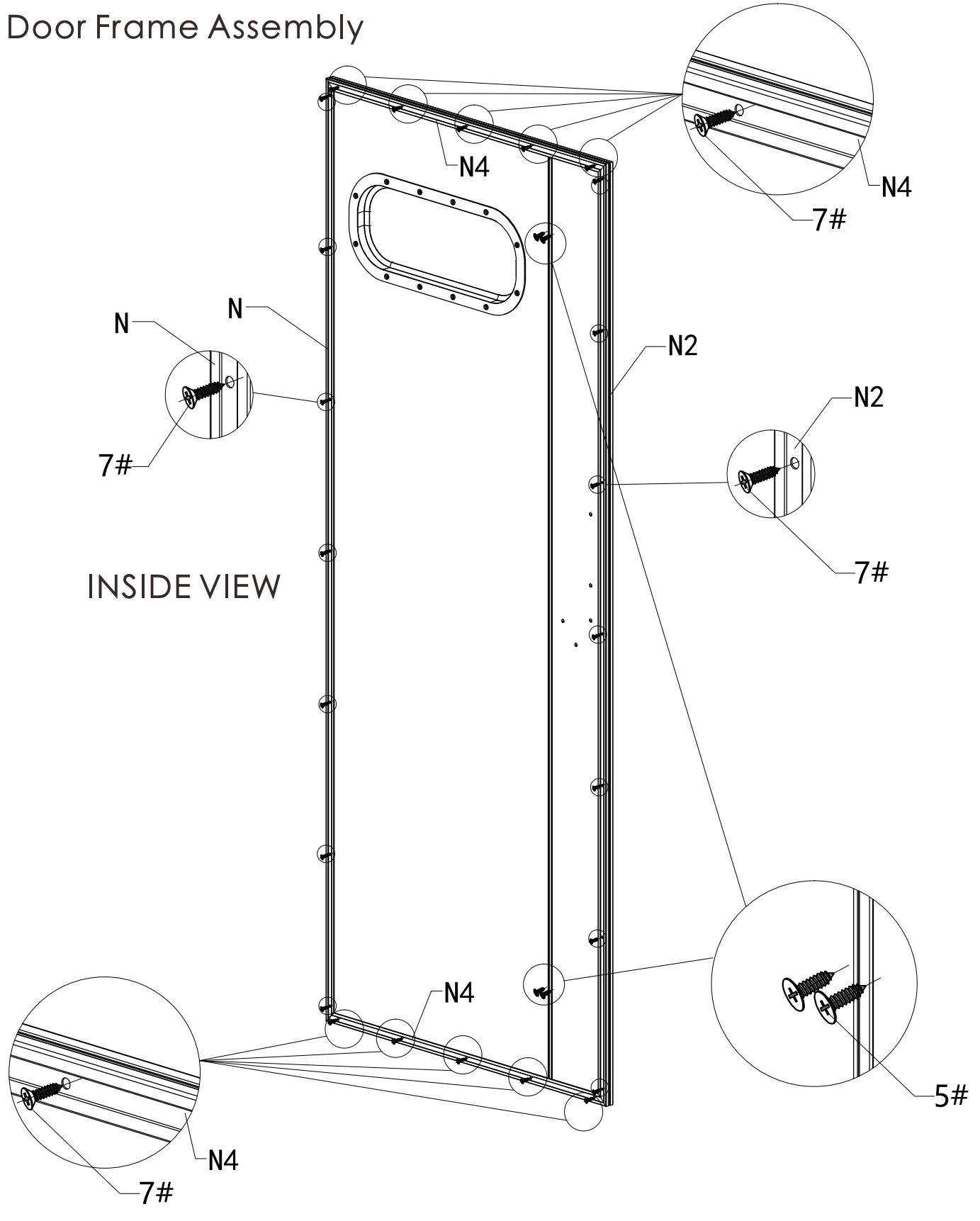



GJF016-x1



12# - x2



13# - x3

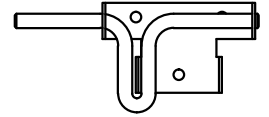

Q-x1

## Doorknob and Locks Assembly

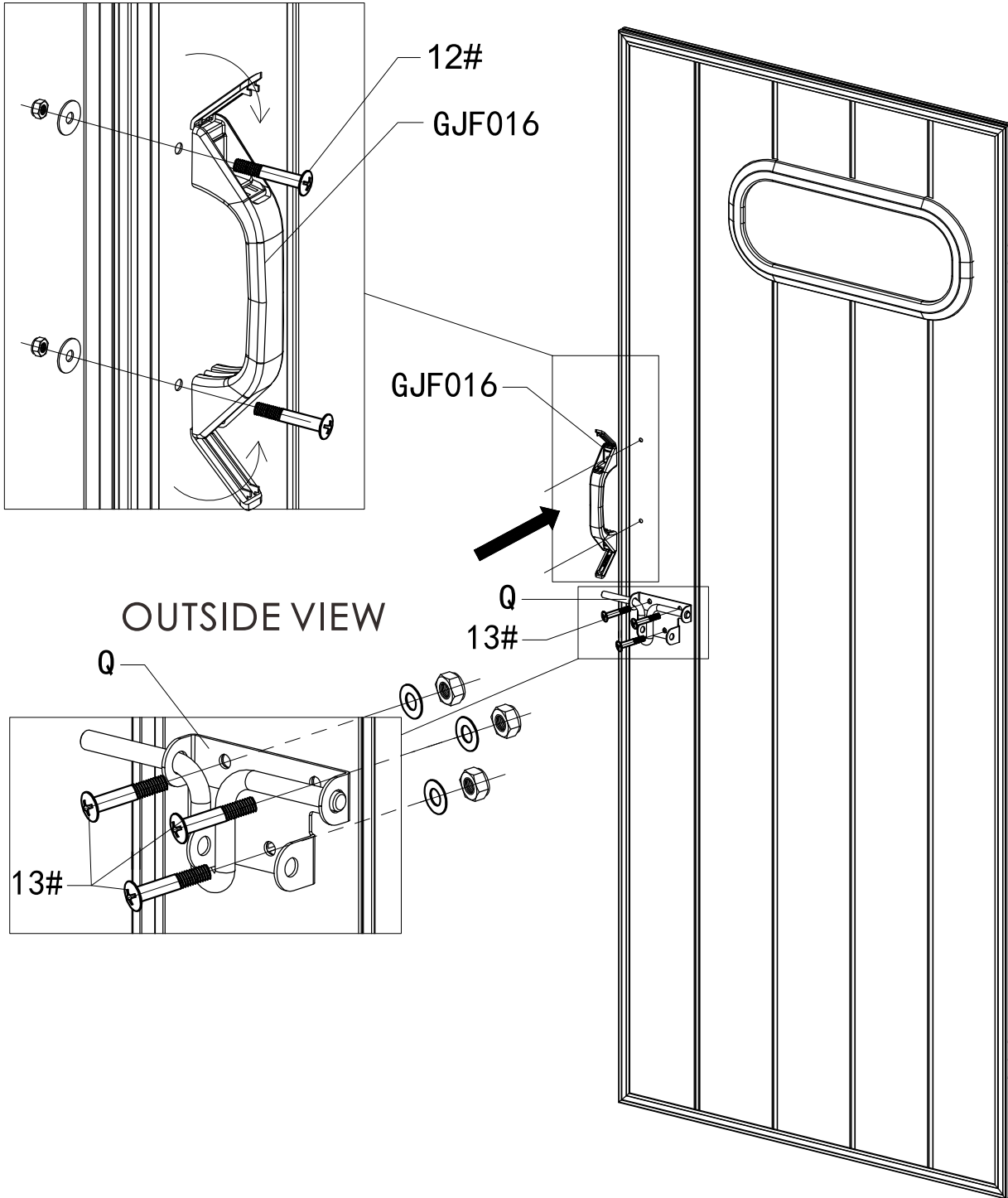

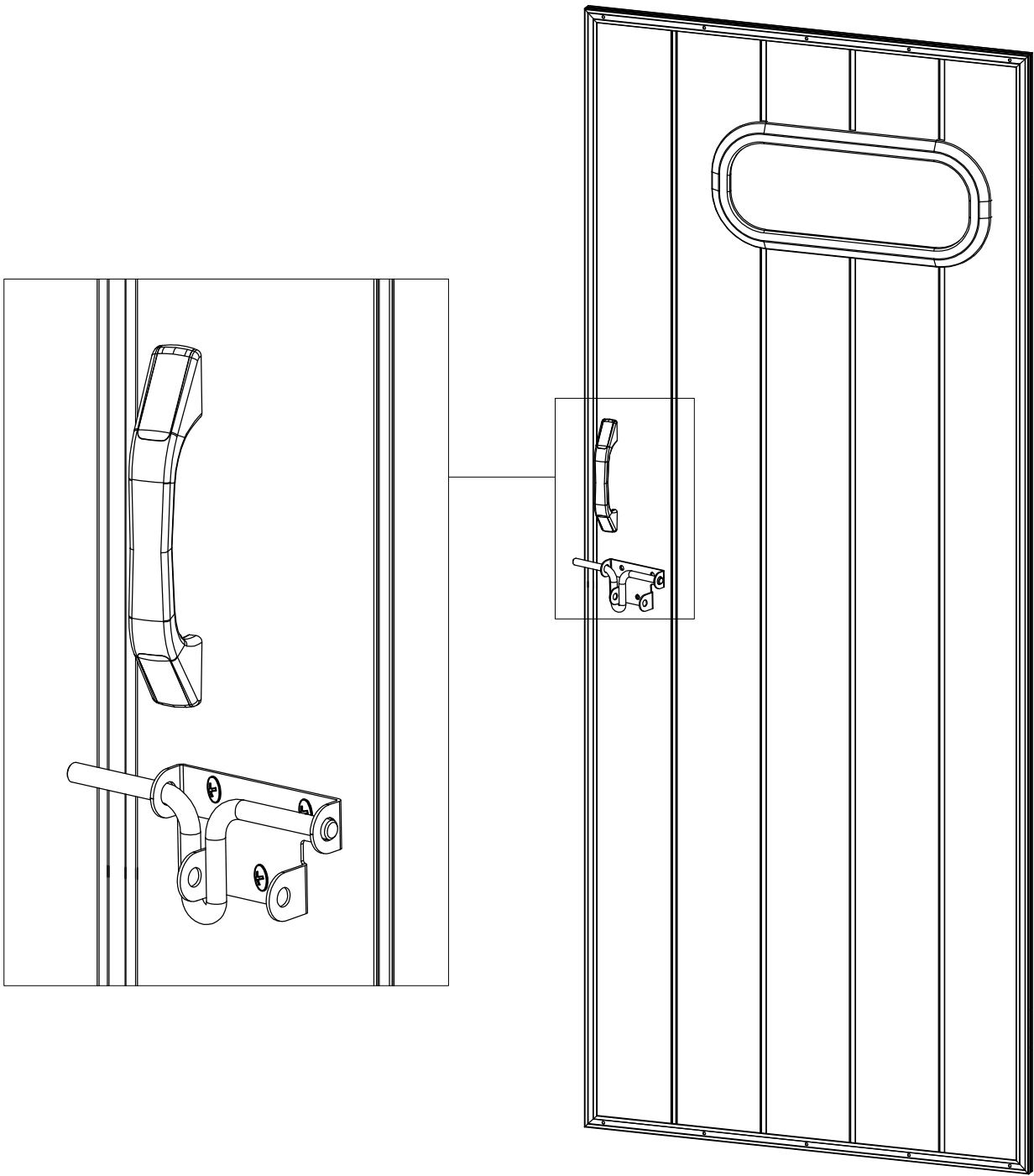

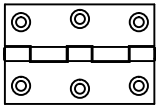

HY - x4



7# - x12

## Assemble the hinges

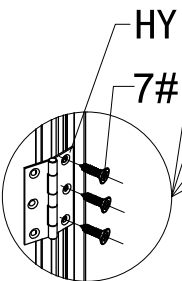
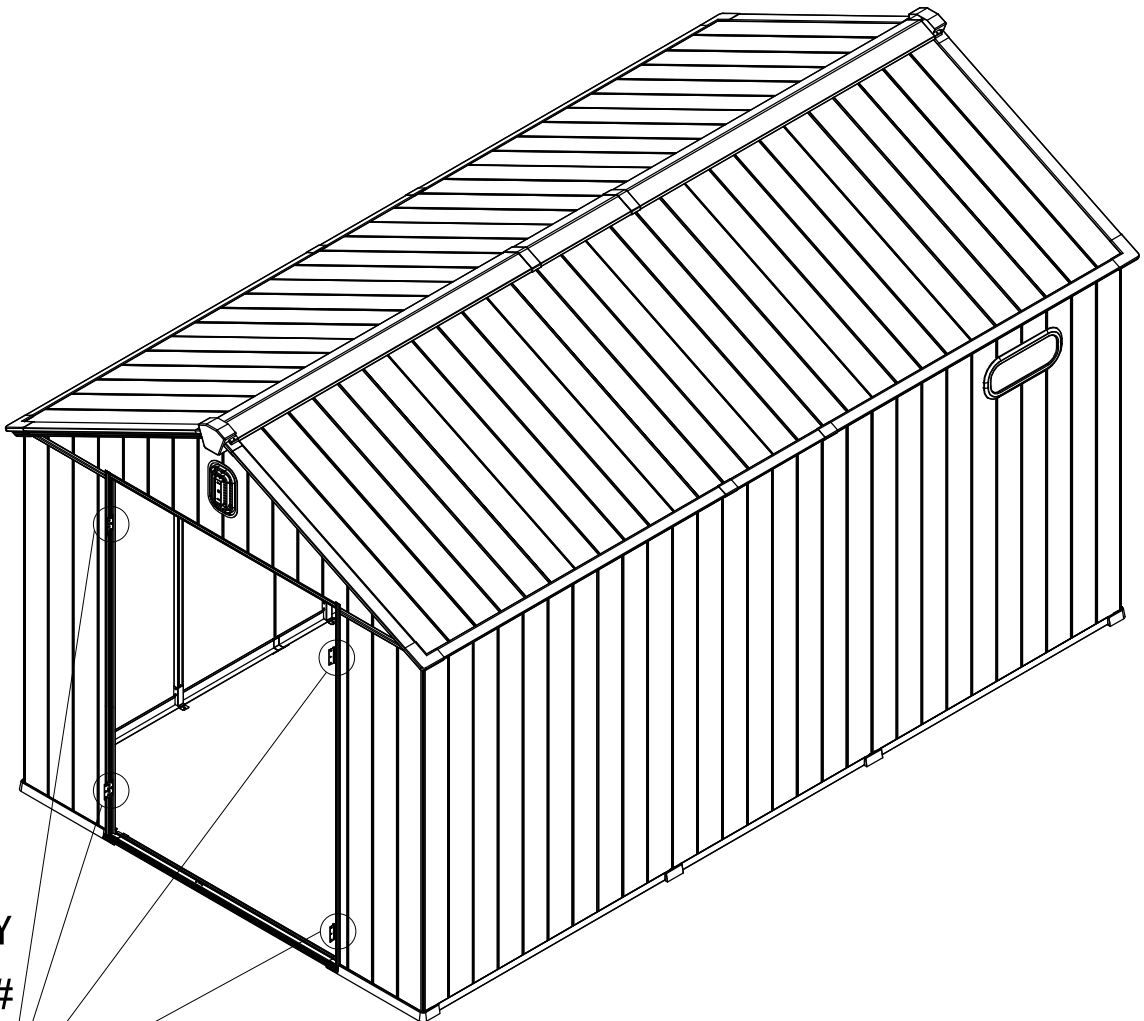

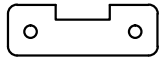

P - x1



7# - x14

Secure #P and base #A with 2 screws 7#.

Note: The notch of #P faces inward.

Secure 2 doors and 4 hinges with 12 screws 7#.

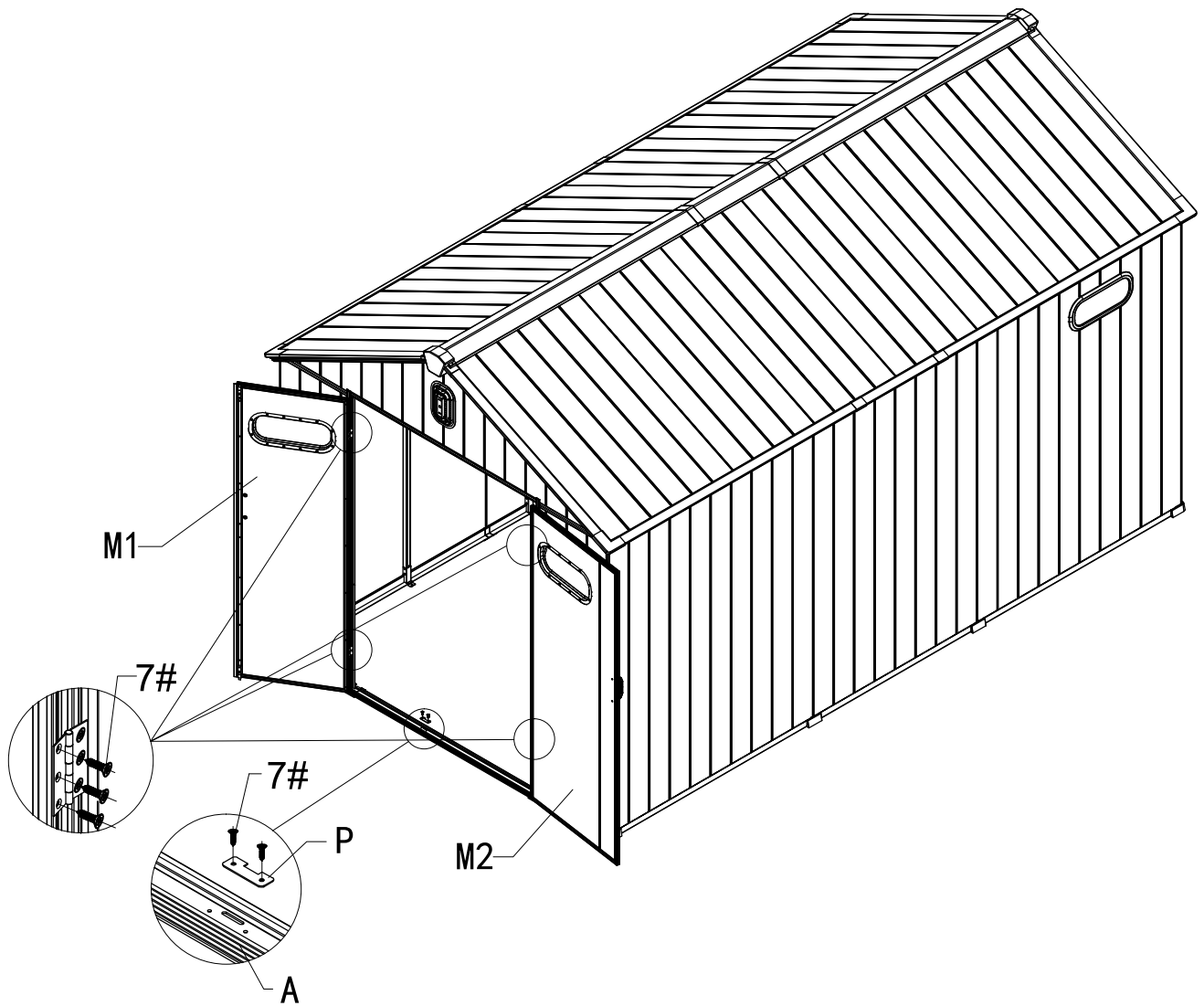

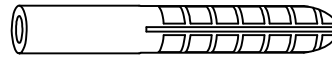

14# - x12

(Drill holes in the ground first)

Secure the chassis to the foundation with eight 14# expansion screws.

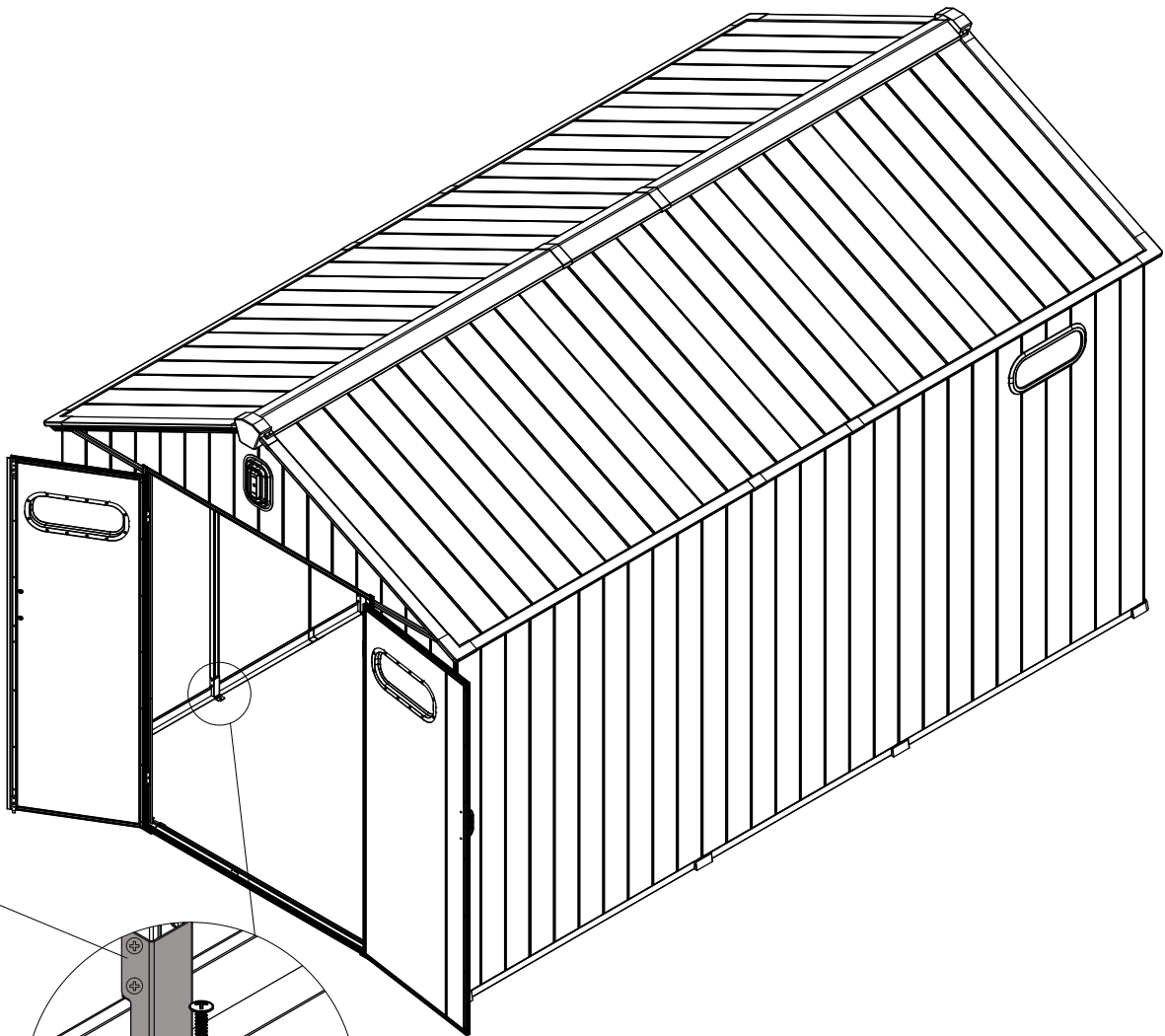

H1

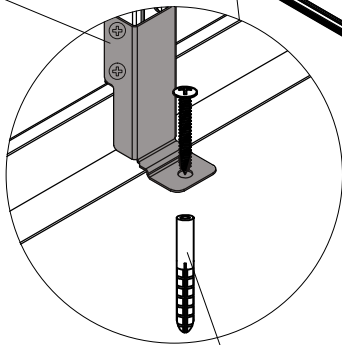

14#



## Thanks for your purchase.

At domi outdoor living, we believe in our products.

That's why we provide a 12-month warranty and friendly, easy-to-reach after-sales service. So, if you have any questions about our product or assembly, please feel free to contact us. We are here for you.

**Support:**  

**After-sales contact email:**

[service@domioutdoorliving.com](mailto:service@domioutdoorliving.com)

Please have your order ID available if you reach out for support.

If you have damaged parts or product, please send us photos for an immediate response.