

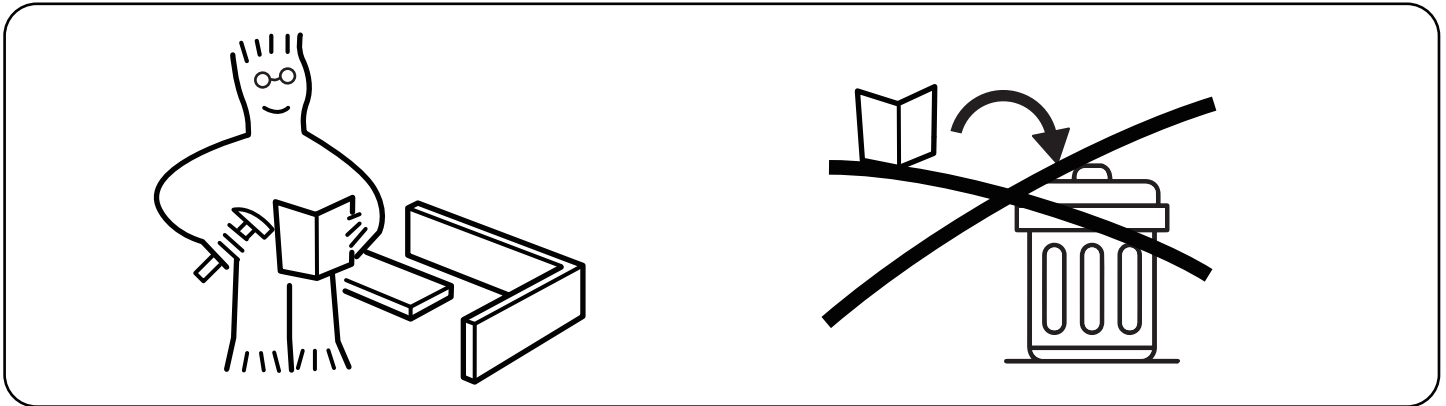

# **ASSEMBLY INSTRUCTIONS**

# NOTICE

IMPORTANT, RETAIN FOR FUTURE REFERENCE: READ CAREFULLY  
WICHTIG, FÜR SPÄTERE NACHSCHLAGE AUFBEWAHREN: SORGFÄLTIG LESEN  
IMPORTANTE, GUARDAR PARA REFERENCIA POSTERIOR: LEER ATENTAMENTE  
IMPORTANTE, CONSERVARE PER RIFERIMENTI FUTURI: LEGGERE ATTENTAMENTE  
IMPORTANT, À CONSERVER POUR RÉFÉRENCE FUTURE : LIRE ATTENTIVEMENT



Assemble on a flat, clean and soft surface.  
Auf einer flachen, sauberen und weichen Oberfläche zusammenbauen.  
Assembler sur une surface plate, propre et douce.  
Assemblare su una superficie piatta, pulita e morbida.  
Ensamblar sobre una superficie plana, limpia y suave.

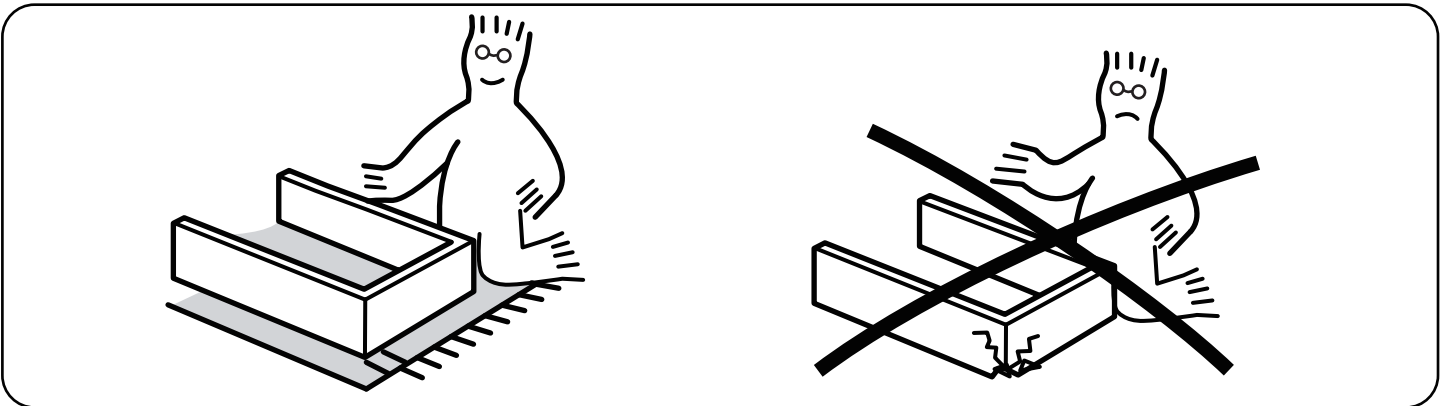

Professional installation is highly recommended.  
Eine professionelle Installation wird dringend empfohlen.  
Une installation professionnelle est fortement recommandée.  
Si raccomanda vivamente l'installazione professionale.  
Se recomienda altamente la instalación profesional.



Periodically check that all components are tightly secured.  
Überprüfen Sie Regelmäßig, Dass Alle Komponenten Fest Gesichert Sind.  
Vérifiez Périodiquement Que Tous Les Composants Sont Bien Fixés.  
Controllare Periodicamente Che Tutti I Componenti Siano Ben Fissati.  
Verifique Periódicamente Que Todos Los Componentes Estén Bien Asegurados.

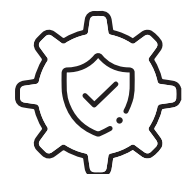

It is recommended that multiple people assemble this product.

Es wird empfohlen, dass mehrere Personen dieses Produkt zusammenbauen.

Il est recommandé que plusieurs personnes assemblent ce produit.

Si raccomanda che più persone assemblino questo prodotto.

Se recomienda que varias personas ensamblen este producto.

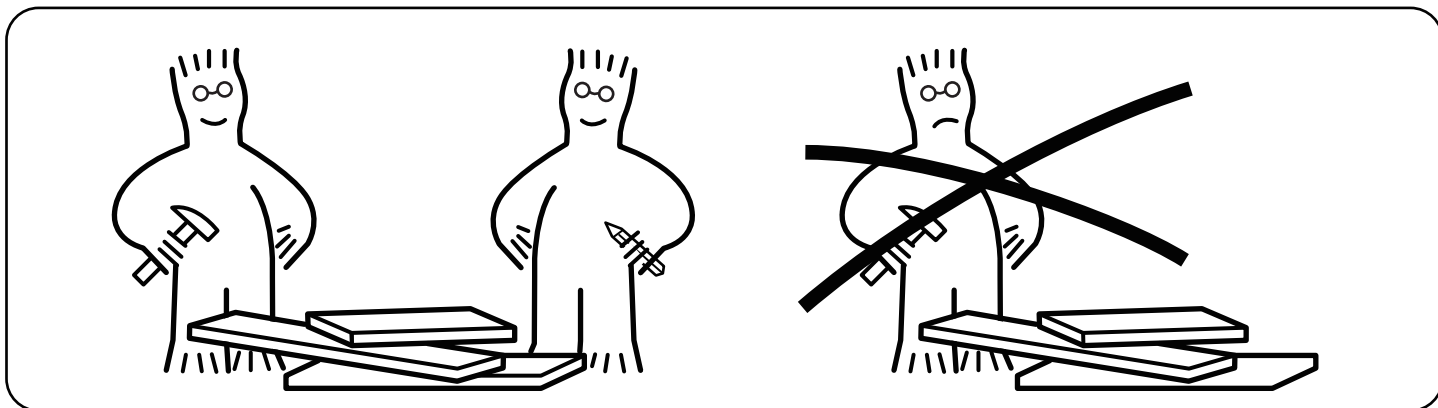

Please have the following auxiliary tools ready:

Bitte haben Sie die folgenden Hilfswerkzeuge bereit:





Veillez avoir les outils auxiliaires suivants à portée de main:

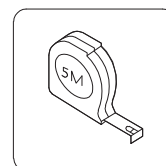
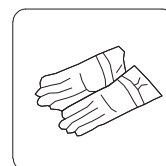
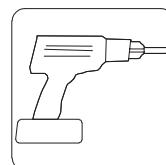



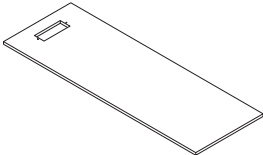
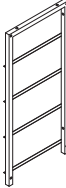
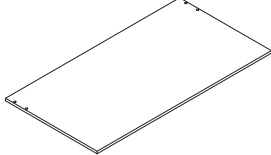
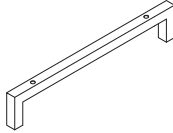
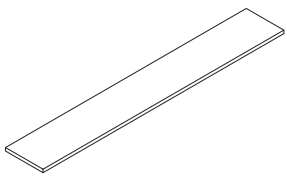
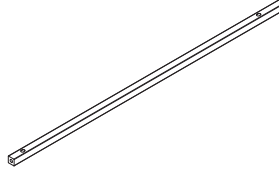
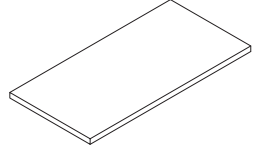
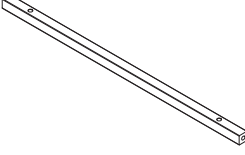
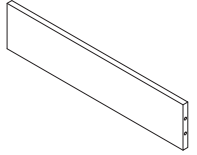
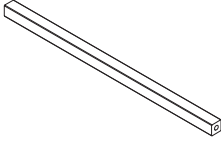
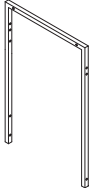
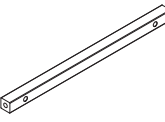

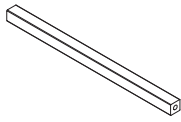

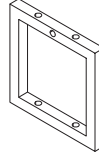

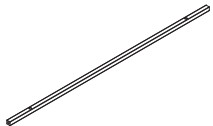

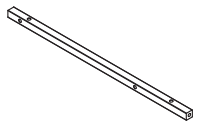
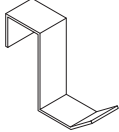

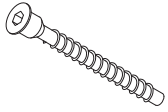
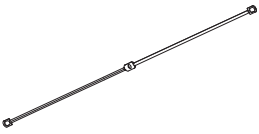
Si prega di avere pronti i seguenti strumenti ausiliari:

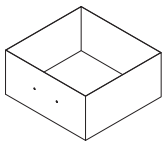
Por favor, tenga listos las siguientes herramientas auxiliares:

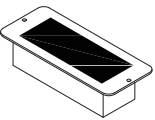
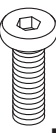
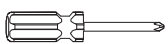
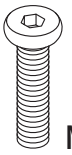

# PARTS

Item no. Nr. N° d'article Articolo No. Artículo No.	Reference Image Referenzbild Image de référence Immagine di riferimento Imagen de referencia	Qty. Menge Qté. Qtà Cant.	Item no. Nr. N° d'article Articolo No. Artículo No.	Reference Image Referenzbild Image de référence Immagine di riferimento Imagen de referencia	Qty. Menge Qté. Qtà Cant.
1		X1	9		X1
2		X1	10		X1
3		X1	11		X2
4		X1	12		X1
5		X1	13		X1
6		X1	14		X1
7		X1	15		X2
8		X1	16		X2

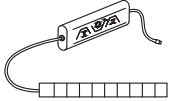
Item no. Nr. N° d'article Articolo No. Artículo No.	Reference Image Referenzbild Image de référence Immagine di riferimento Imagen de referencia	Qty. Menge Qté. Qtà Cant.	Item no. Nr. N° d'article Articolo No. Artículo No.	Reference Image Referenzbild Image de référence Immagine di riferimento Imagen de referencia	Qty. Menge Qté. Qtà Cant.
17		X1	E	 M6	X10
18		X1	F		X2
19		X2	G	 M7X40mm	X6
20		X2	H	 M3.5X12mm	X2
21		X4	I	 M3.5X12mm	X8
22		X4	J		X4
A	 M6X10mm	X2	K		X1
B	 M6X23mm	X12	L		X1
C	 M6X28mm	X38	M		X1
D	 M6	X10	O		X1
			N		X1

# EXPLODED VIEW

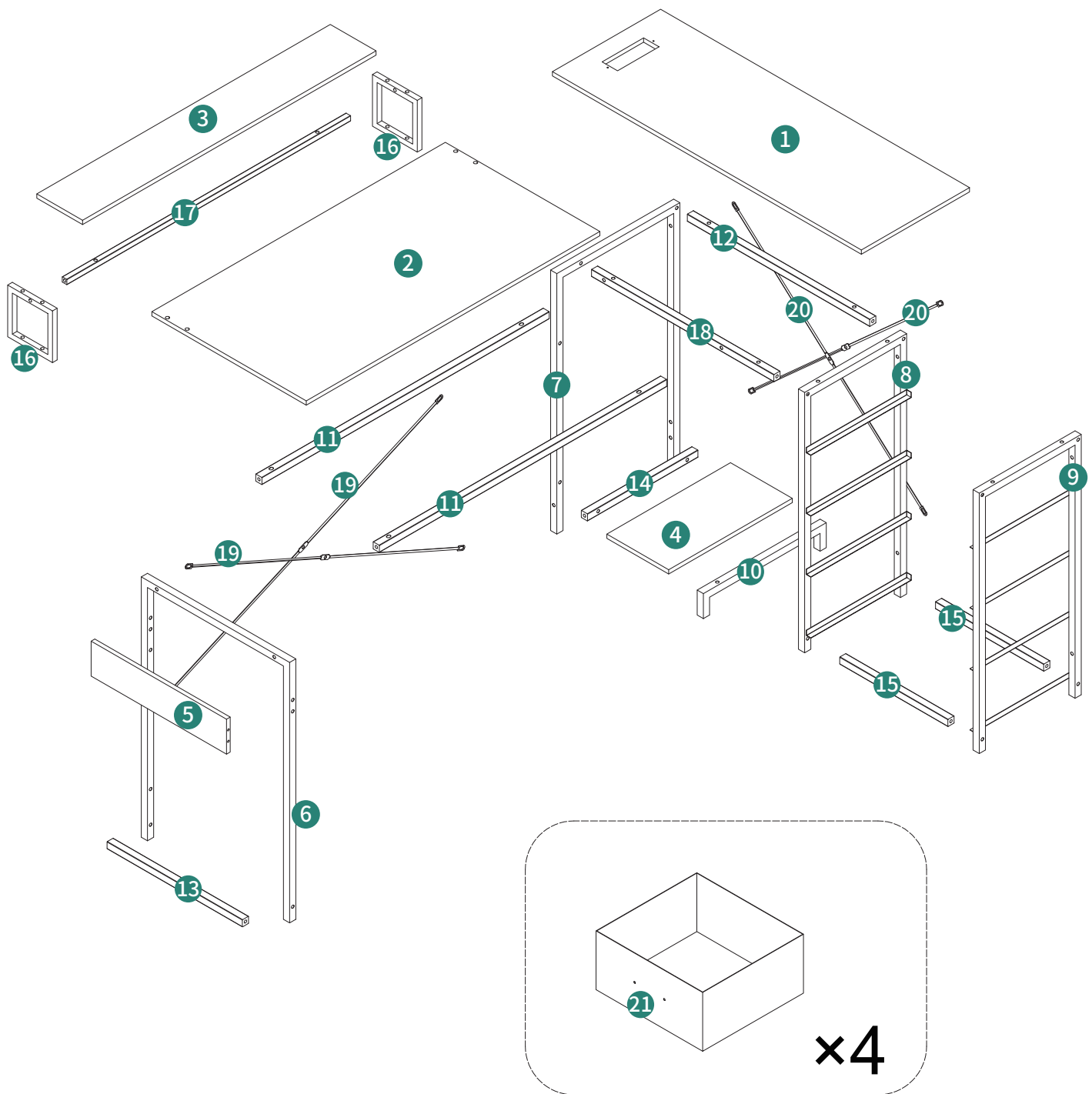

# COMBINATION FORM

**L1 ~ L13**

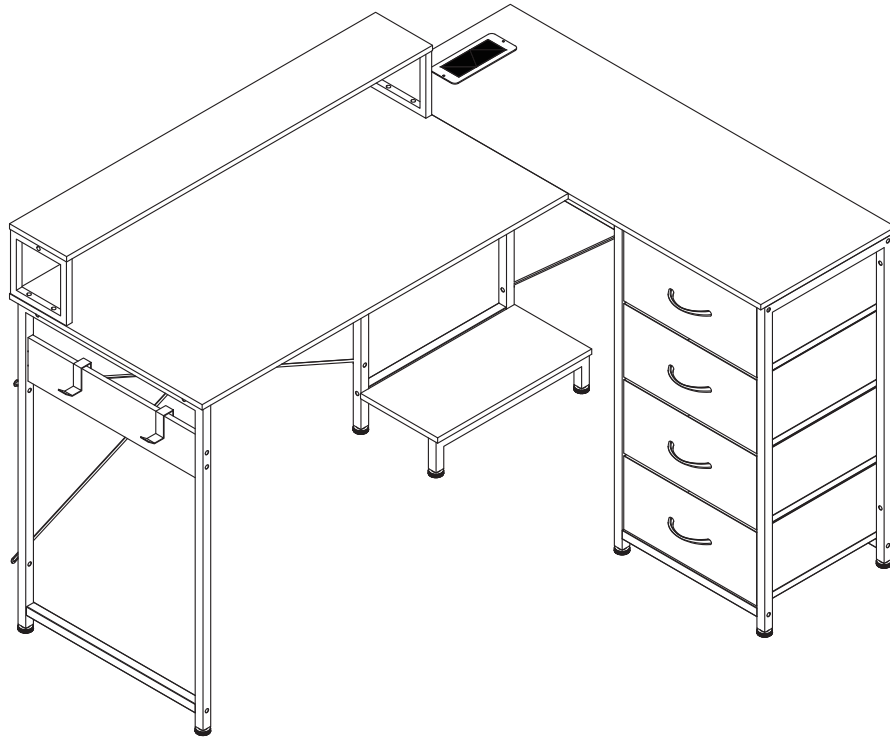

**OR**

**R1 ~ R13**

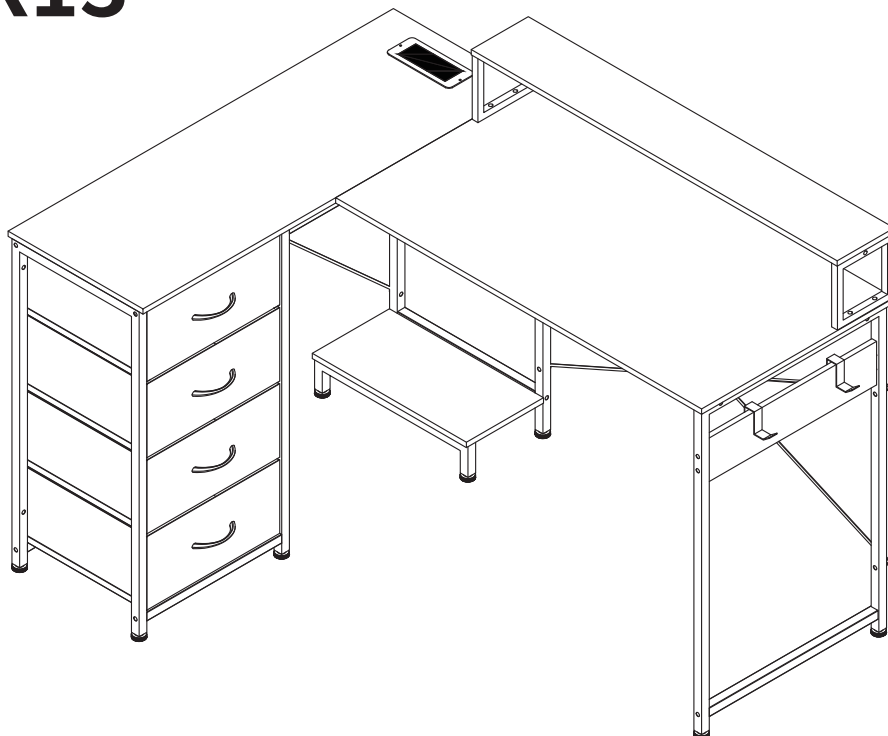

# ASSEMBLY

L1

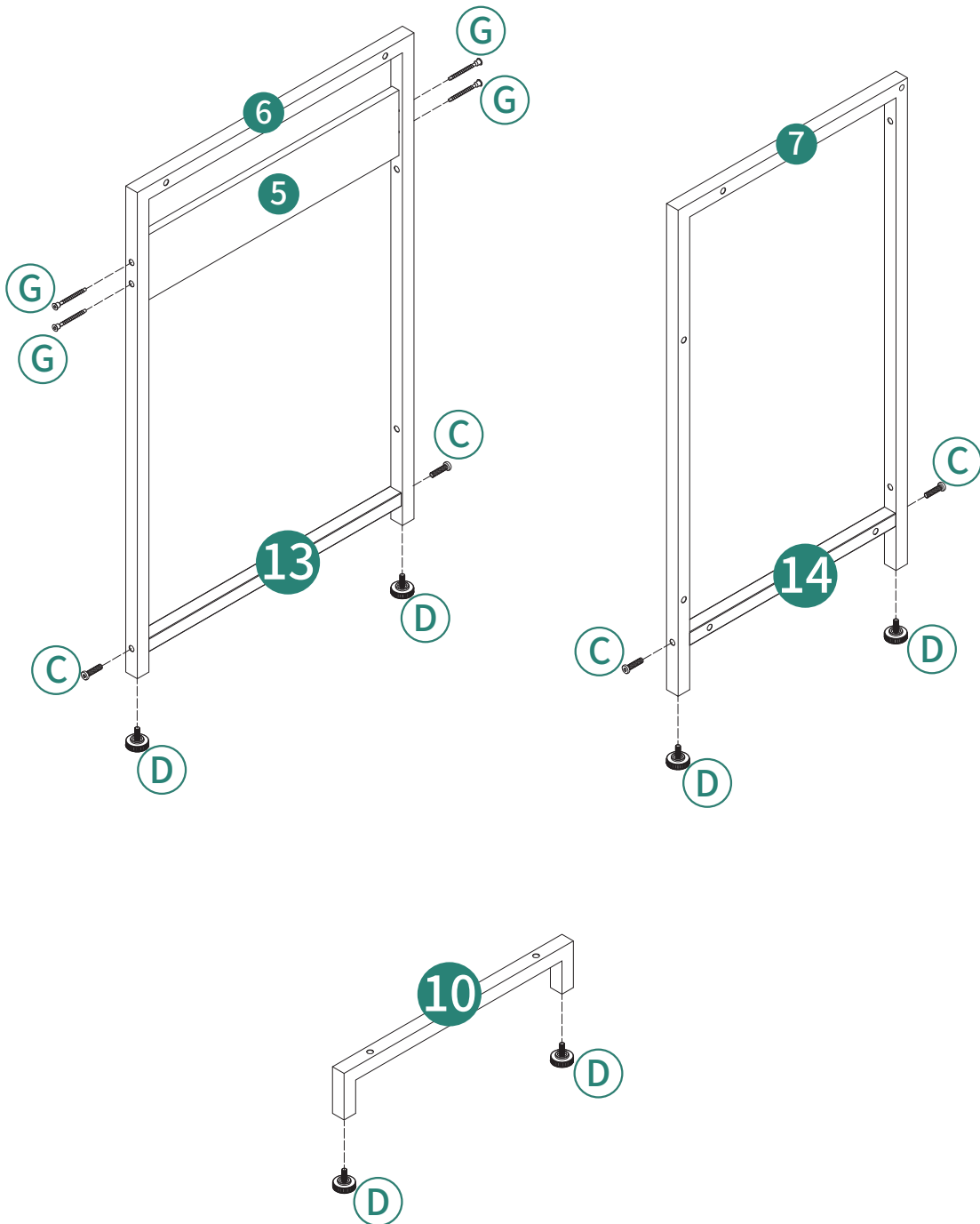
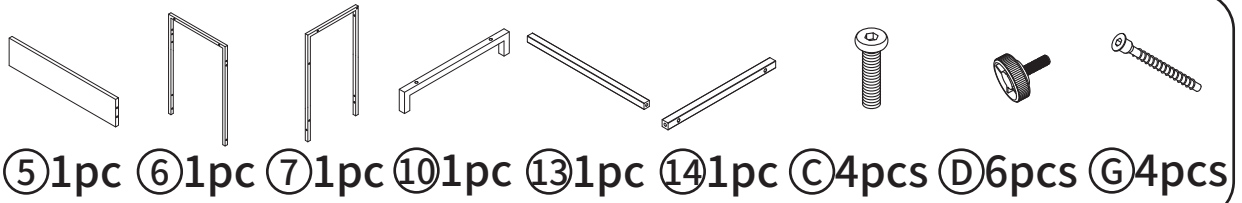

**L2**

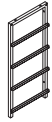

⑧1pc

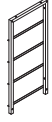

⑨1pc



ⓓ4pcs

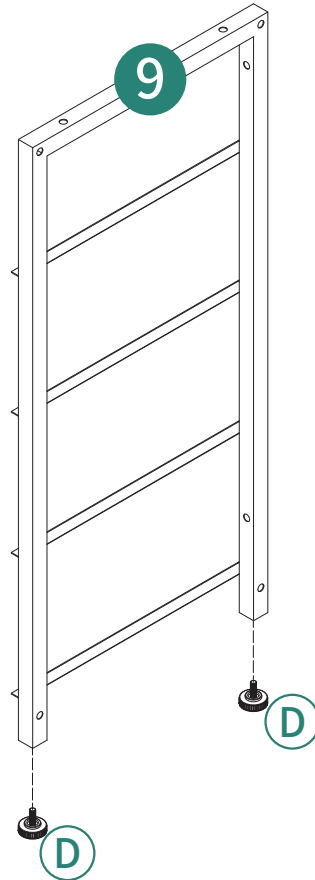
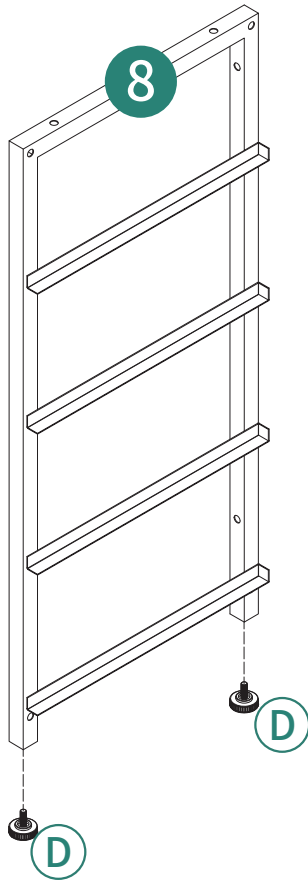

# L3

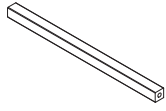

152pcs



C4pcs

The openings are positioned in the same direction.  
Die Öffnungen sind in die gleiche Richtung ausgerichtet.  
Les ouvertures sont positionnées dans la même direction.  
Le aperture sono posizionate nella stessa direzione.  
Las aberturas están colocadas en la misma dirección.

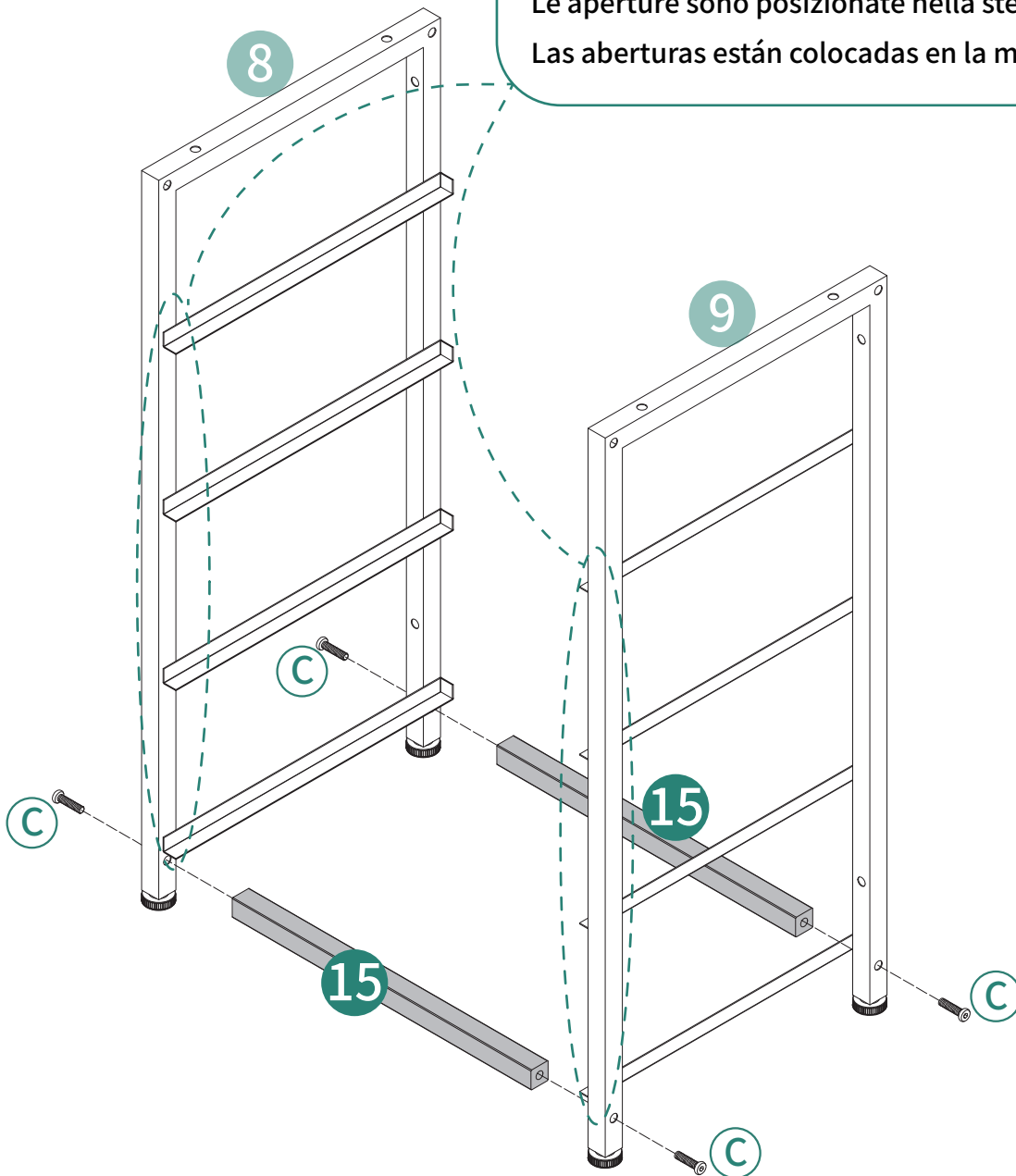

# L4

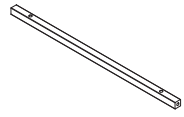

12 1pc

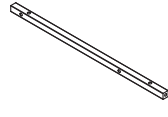

18 1pc



C 4pcs

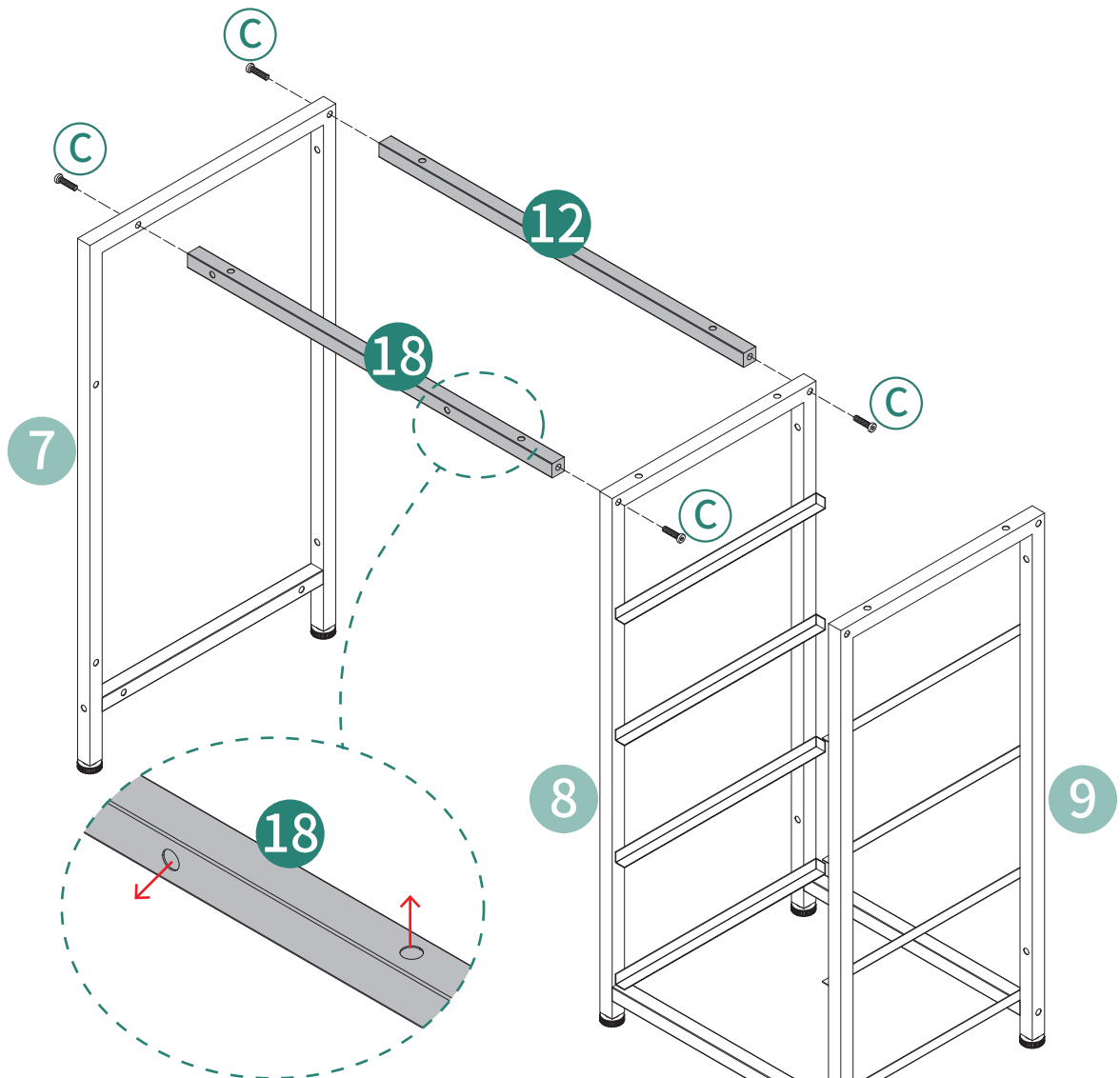

Pay attention to the orientation of the mounting holes during installation.

Achten Sie während der Installation auf die Ausrichtung der Montagelöcher.

Faites attention à l'orientation des trous de montage lors de l'installation.

Prestare attenzione all'orientamento dei fori di montaggio durante l'installazione.

Preste atención a la orientación de los orificios de montaje durante la instalación.

**L5**

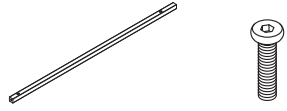

① 2 pcs    ② 4 pcs

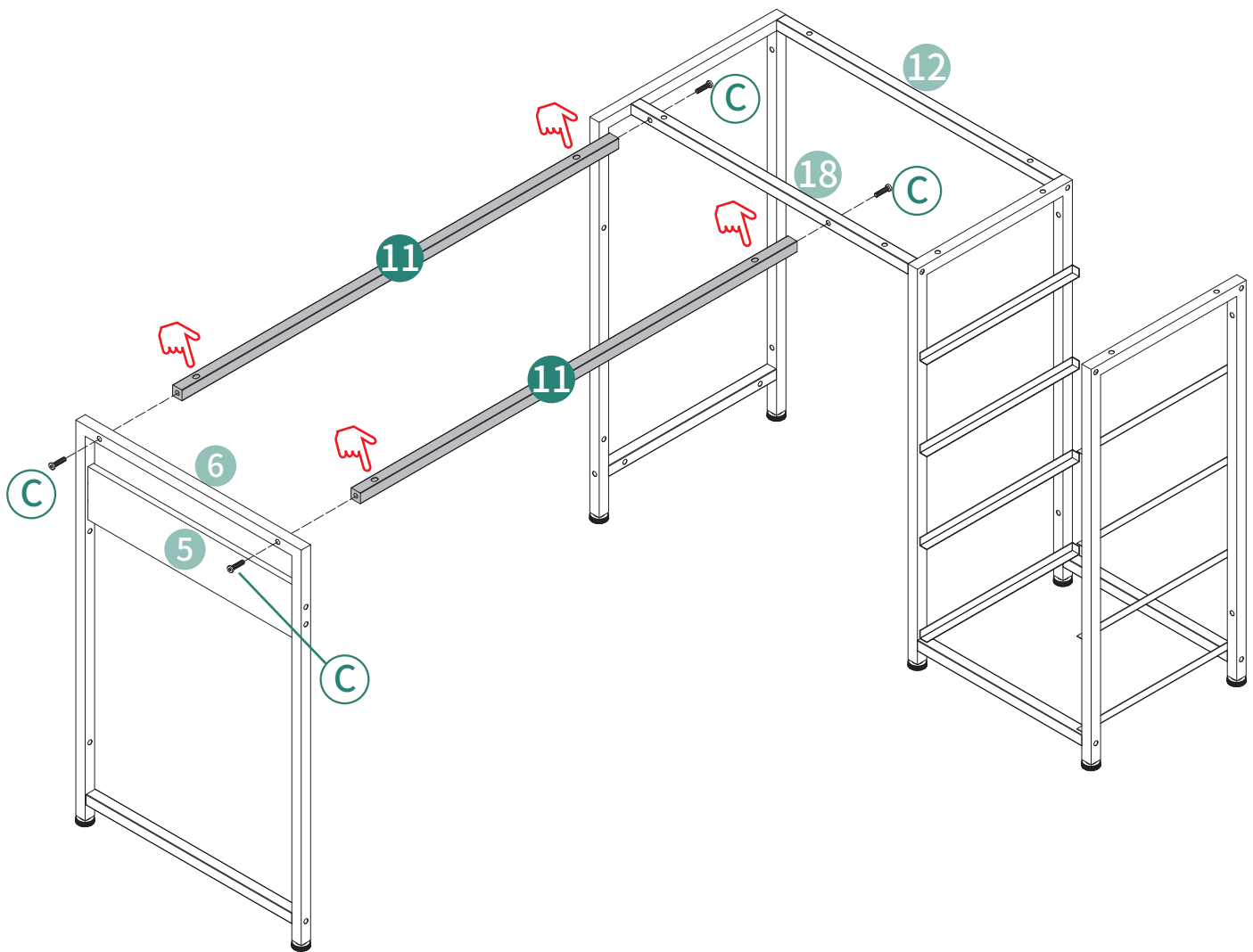

**L6**

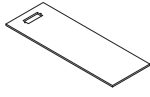

① 1pc

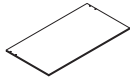

② 1pc



Ⓒ 12pcs

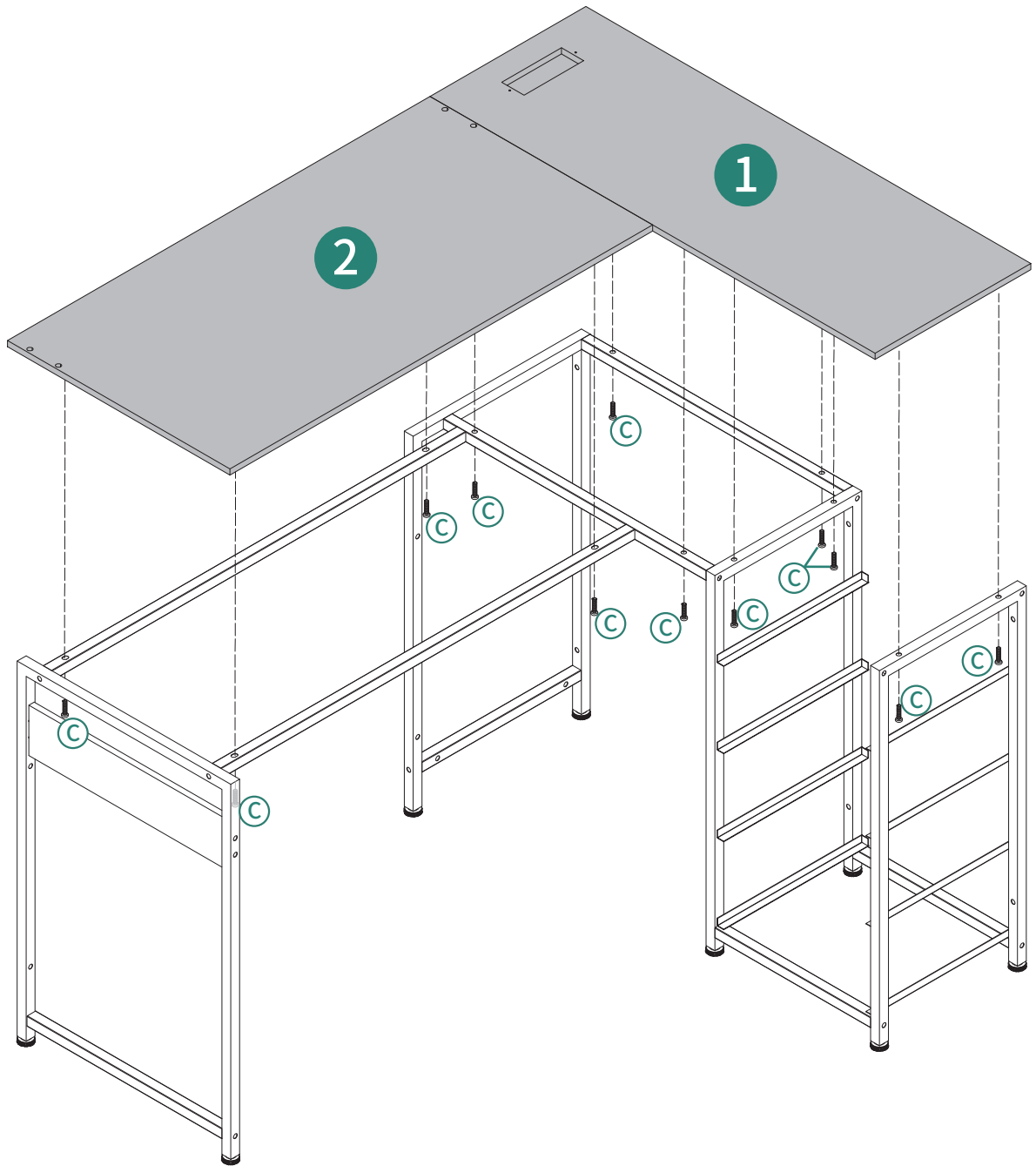

**L7**

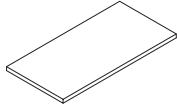

④1pc

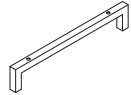

⑩1pc



②2pcs

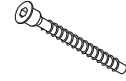

⑥2pcs

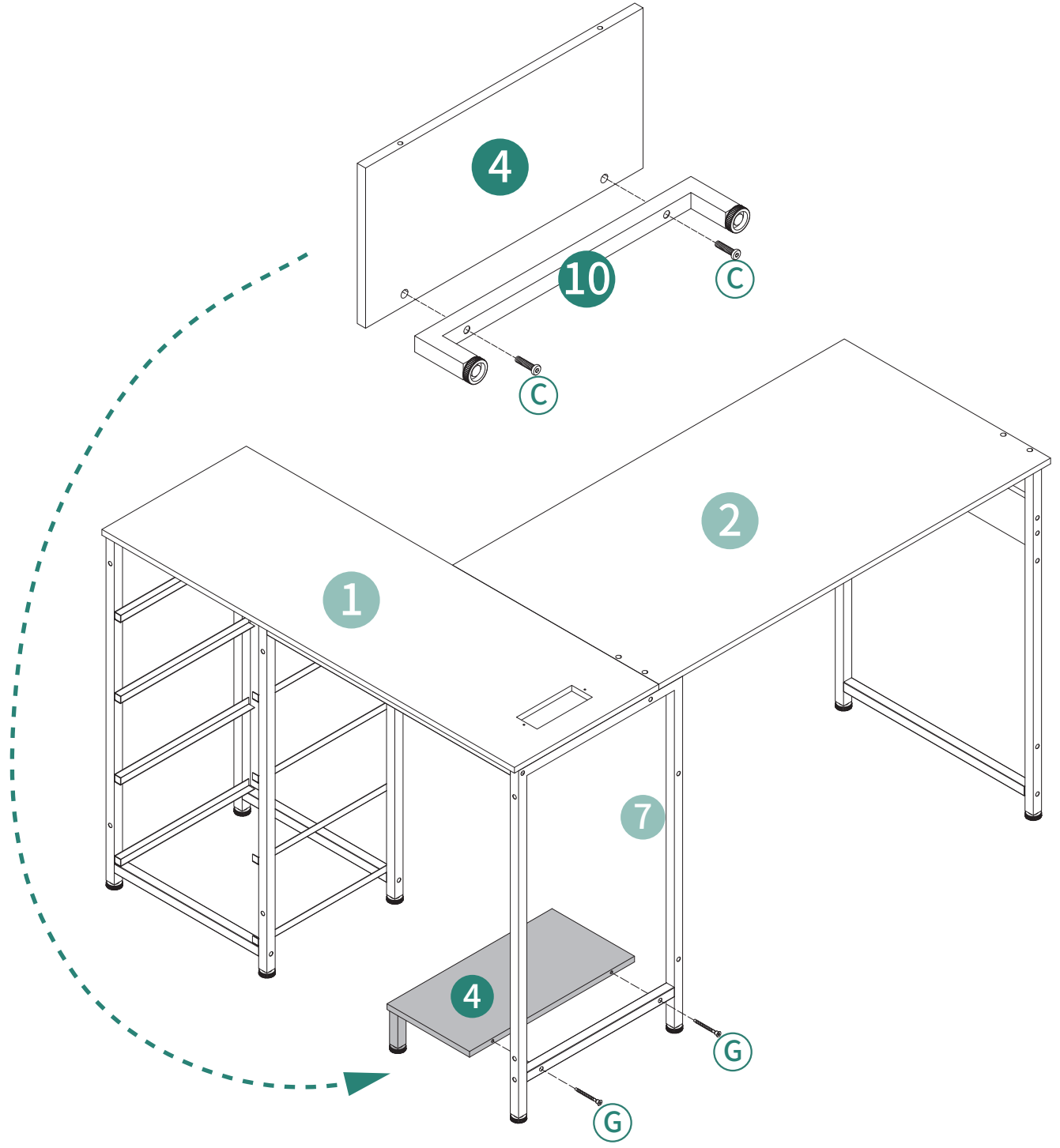

L8



①9 2pcs



②0 2pcs





Ⓐ 2pcs

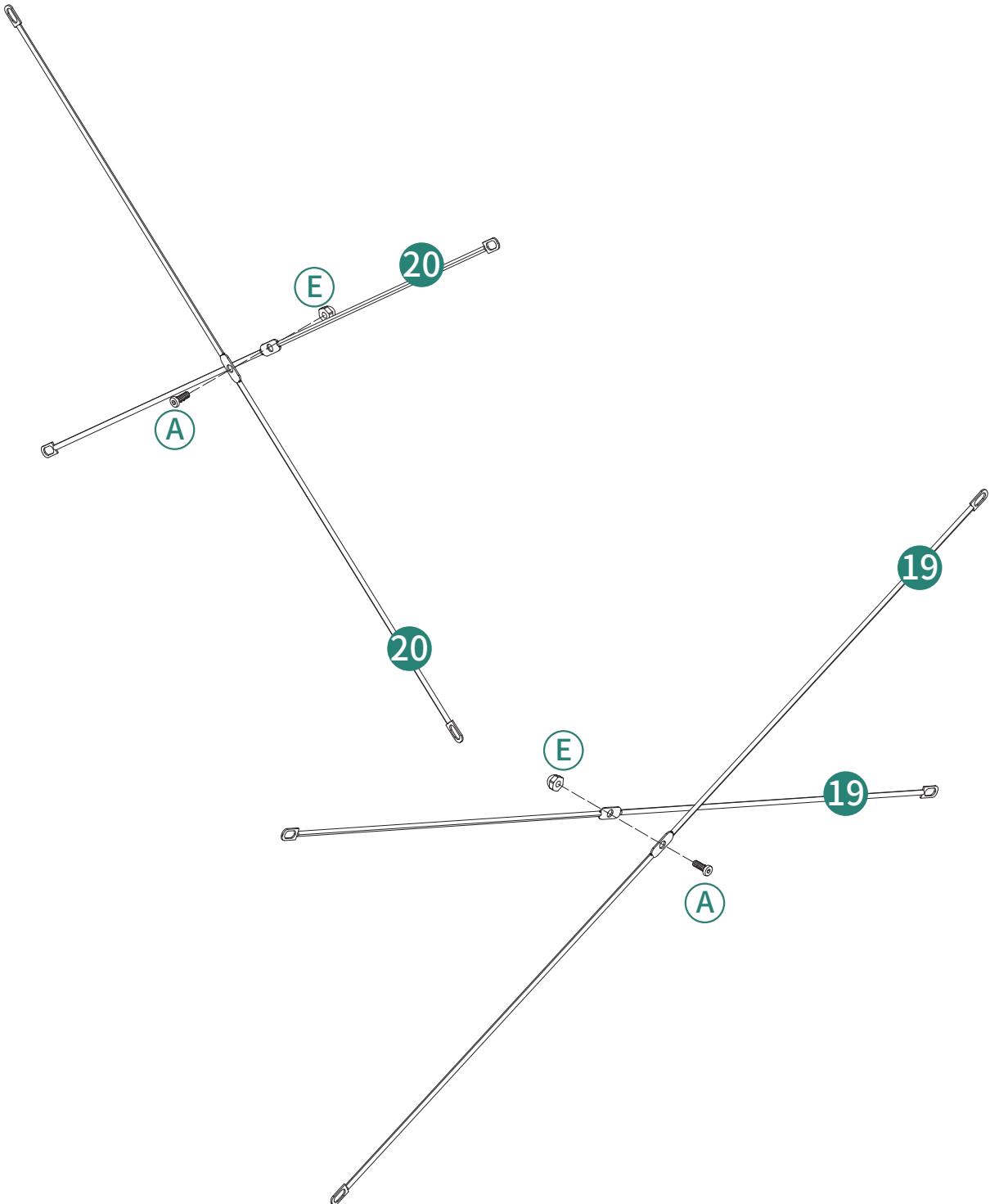

Ⓔ 2pcs



**L9**

 **C8pcs**       **E8pcs**

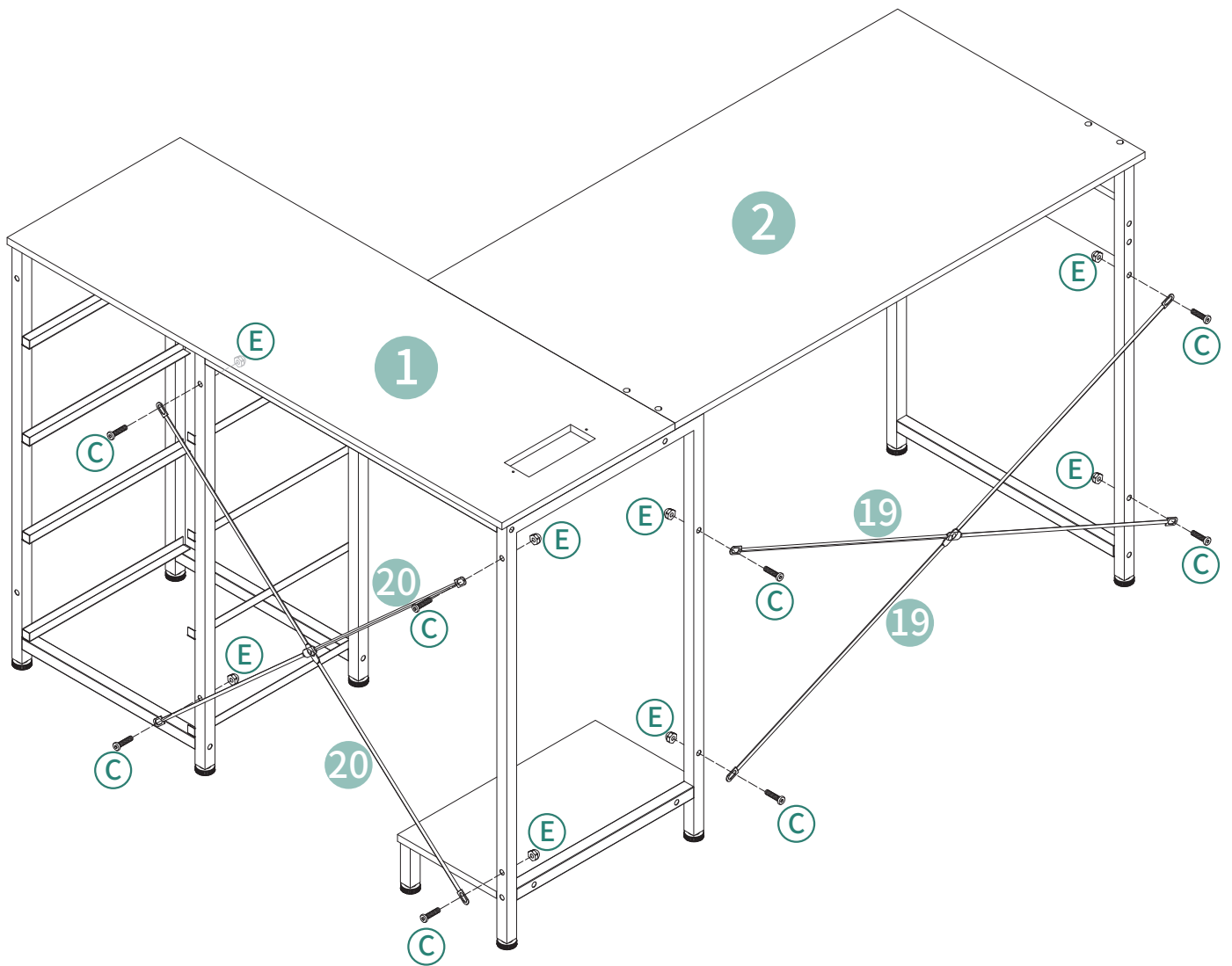

**L10**

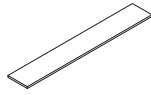

③1pc

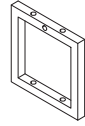

①62pcs

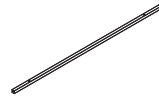

①71pc



①B8pcs

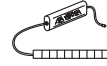

①N1pc

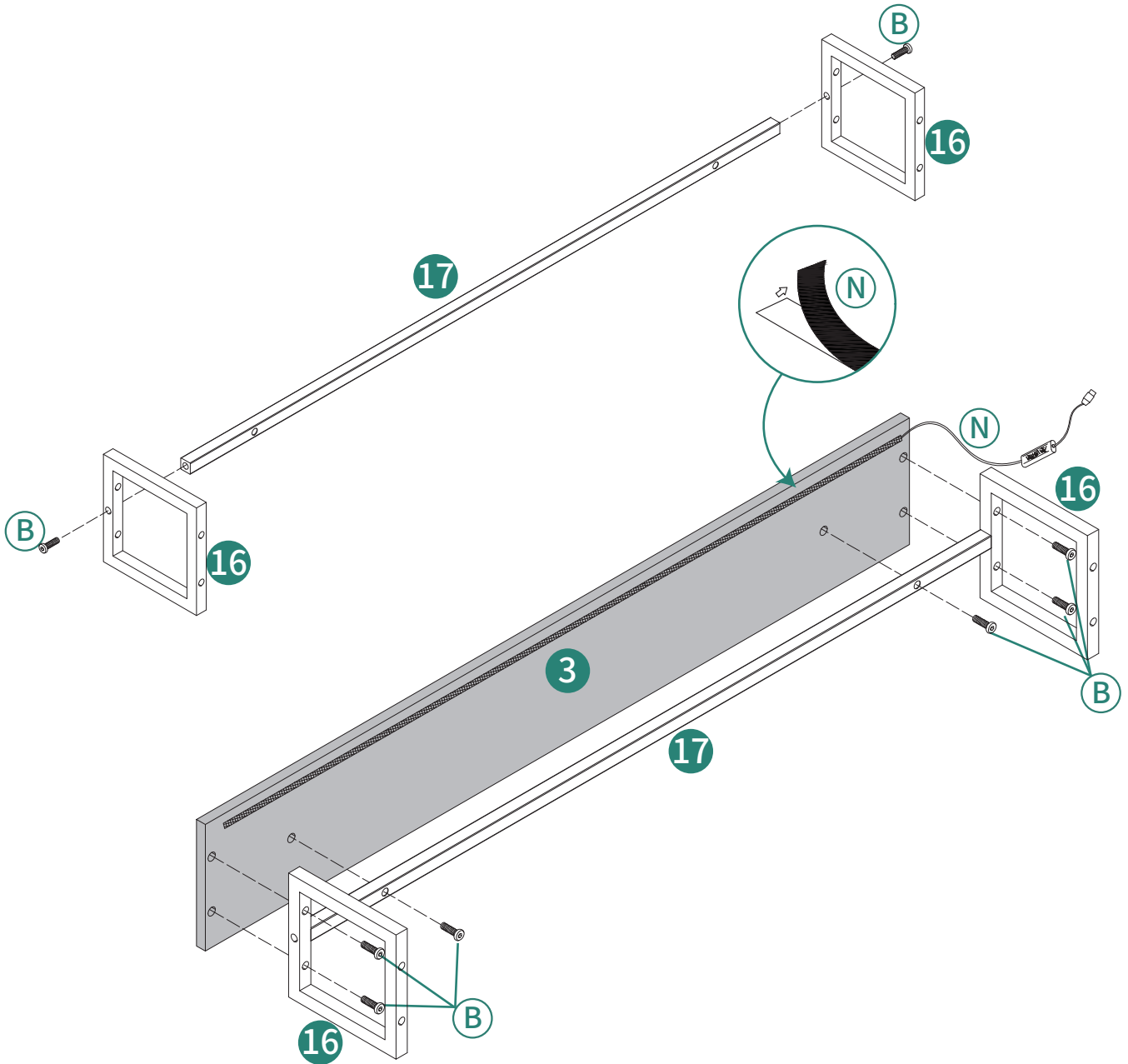

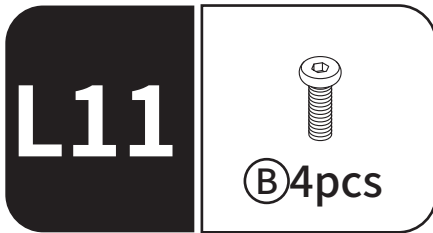

Ensure the N is installed against the wall side.  
Stellen Sie sicher, dass das N gegen die Wandseite installiert ist.  
Assurez-vous que le N est installé contre le côté du mur.  
Assicurati che la N sia installata sul lato del muro.  
Asegúrate de que la N esté instalada contra el lado de la pared.

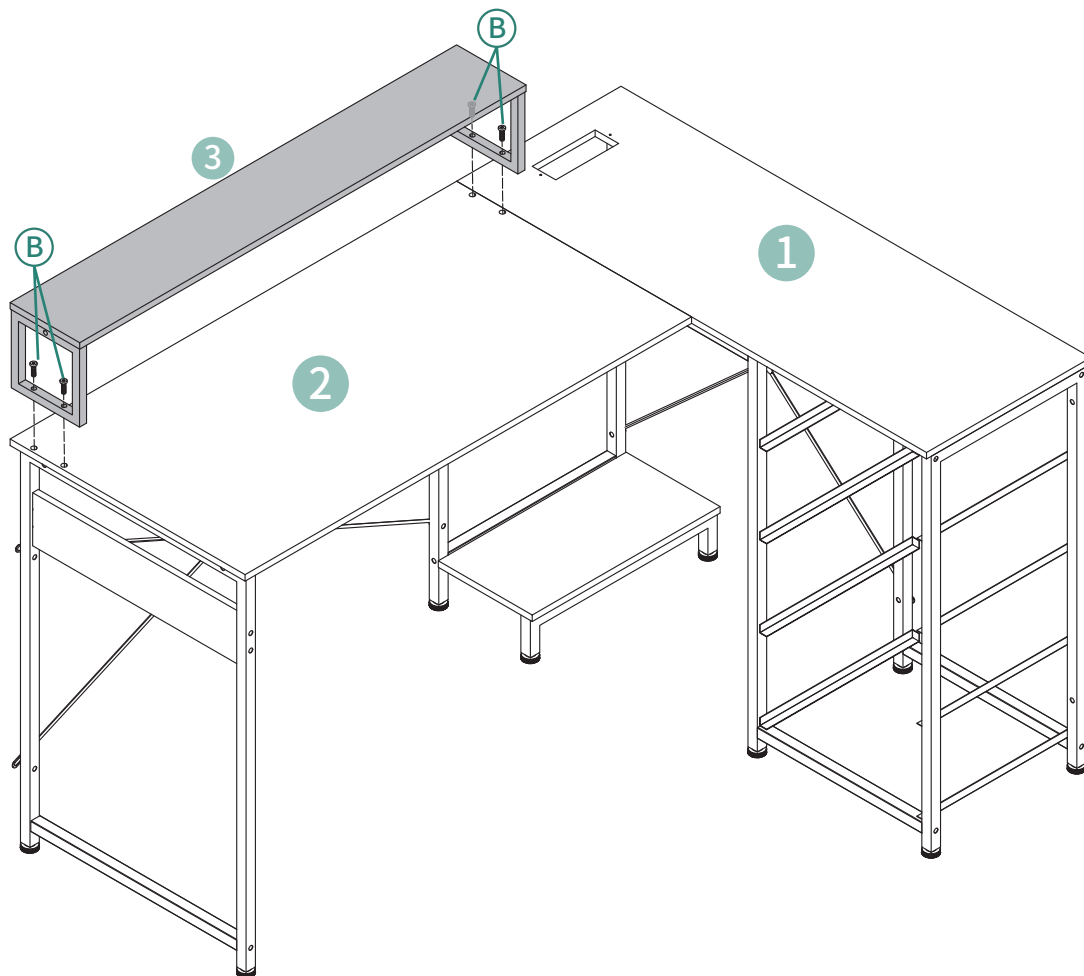

Afix the switch of the light strip in a suitable location.  
Befestigen Sie den Schalter des Lichtstreifens an einem geeigneten Ort.  
Fixez l'interrupteur de la bande lumineuse à un endroit approprié.  
Fissare l'interruttore della striscia luminosa in un luogo adatto.  
Fije el interruptor de la tira de luz en un lugar adecuado.

**L12**

**X4**

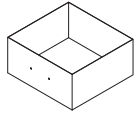

②1 4pcs



②2 4pcs



① 8pcs



④ 4pcs

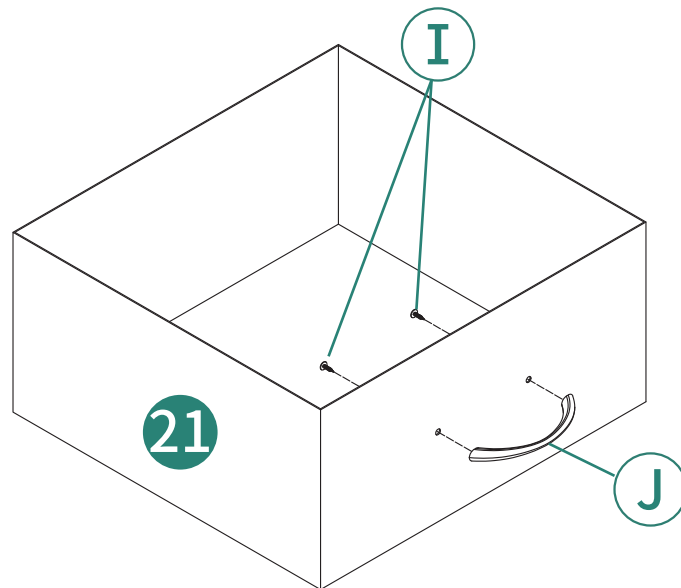
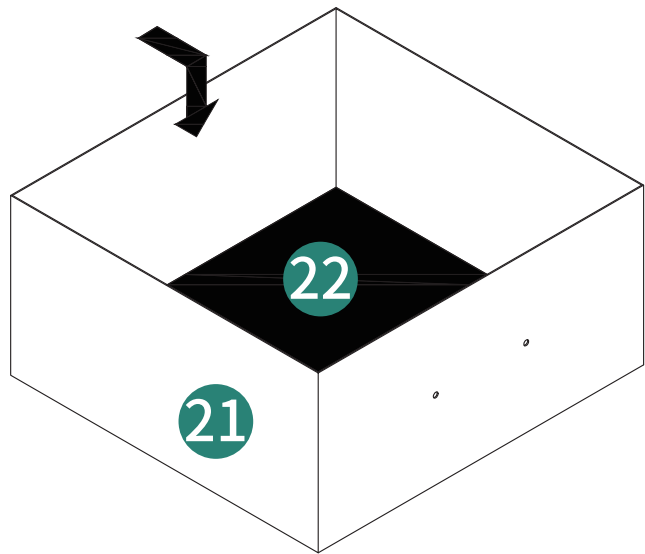
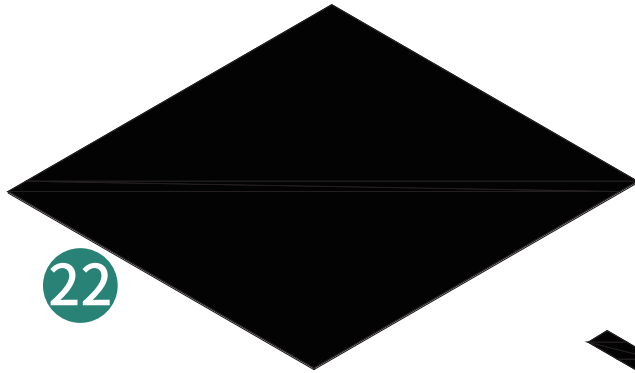

**L13**

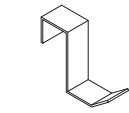

ⓕ2pcs

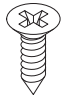

ⓓ2pcs

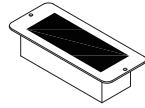

Ⓚ1pc

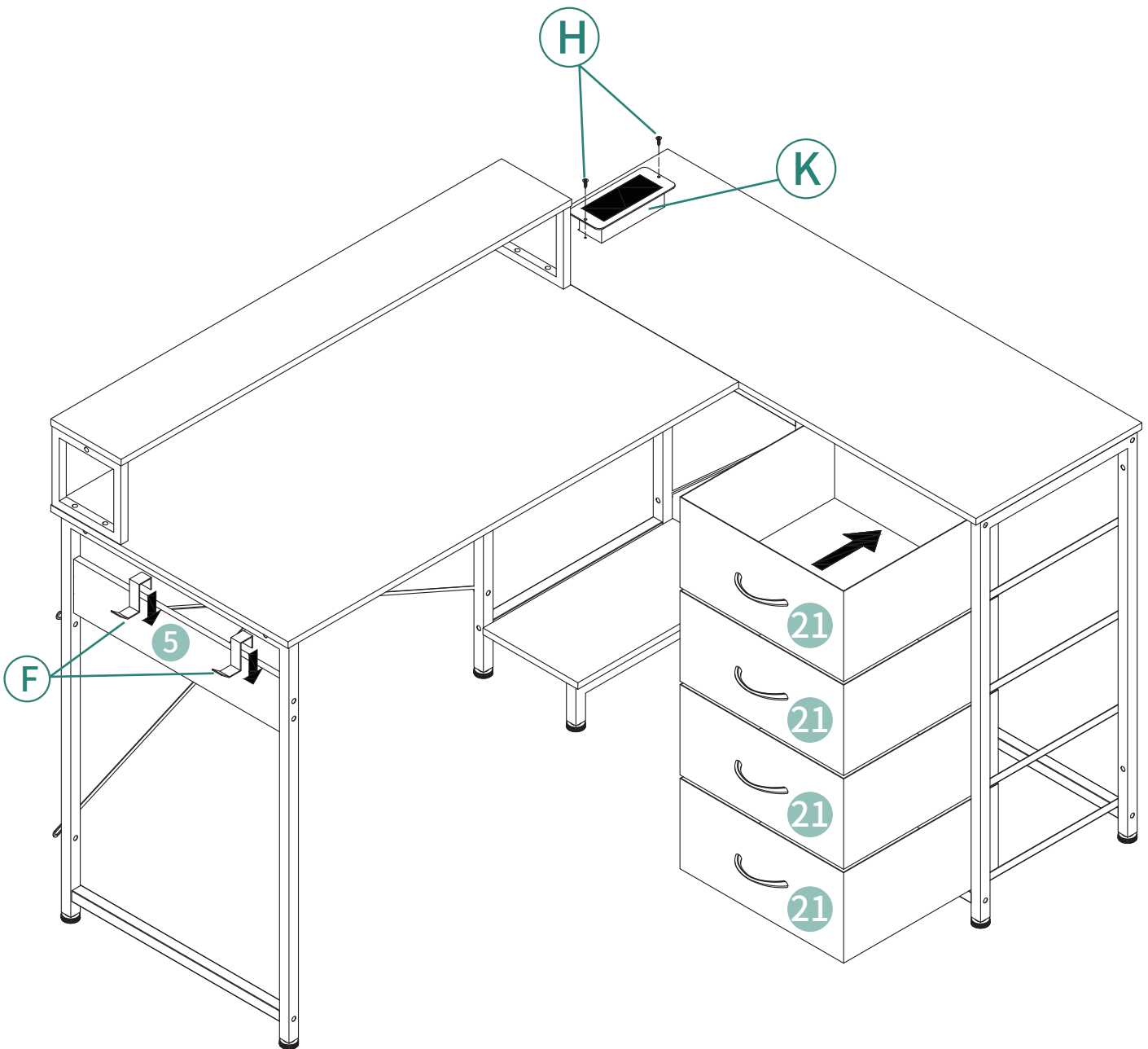

# ASSEMBLY

## R1

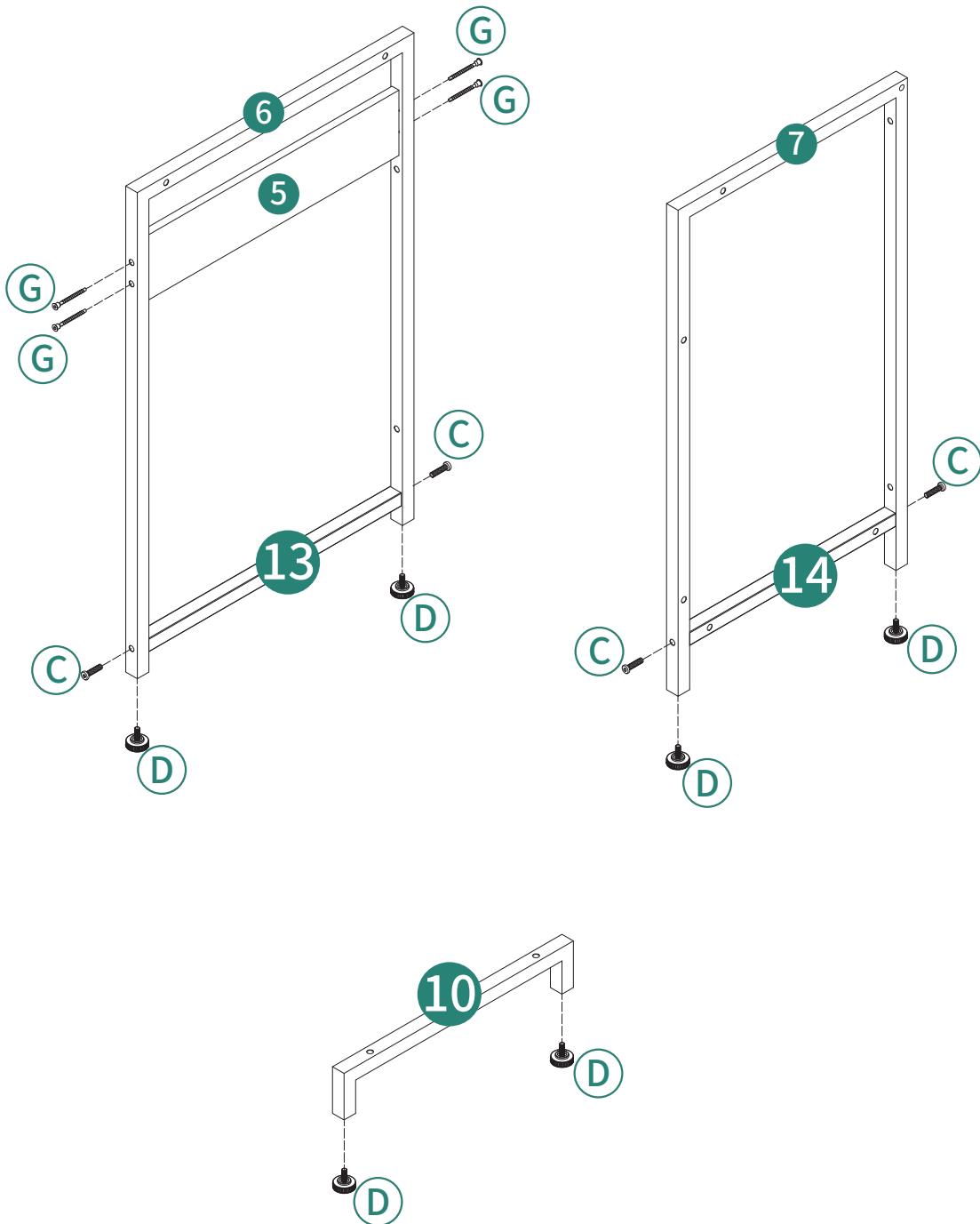
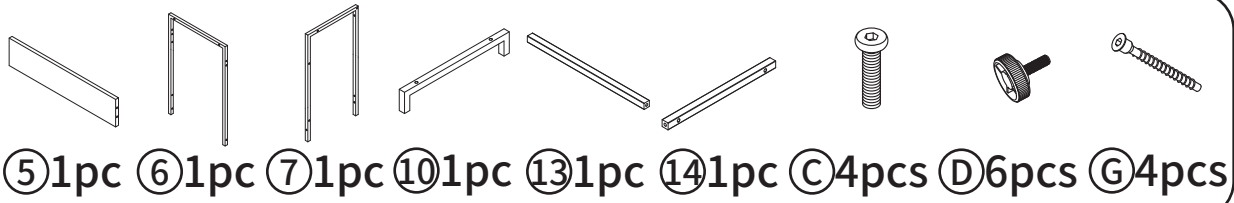

**R2**

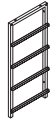

⑧1pc

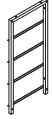

⑨1pc



ⓓ4pcs

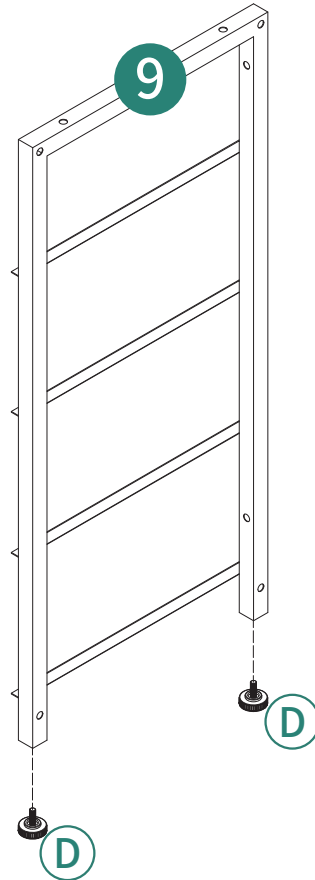
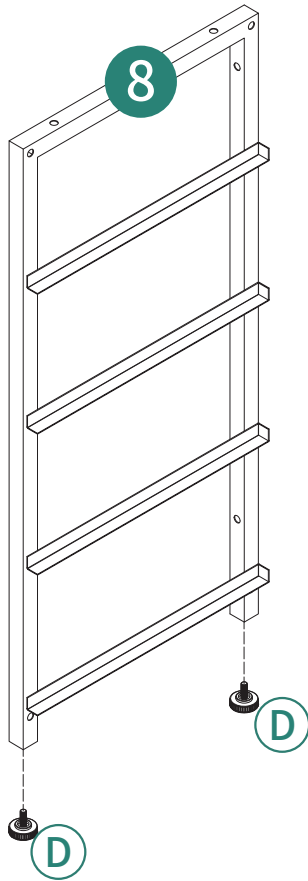

# R3

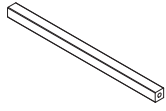

15 2pcs



C 4pcs

The openings are positioned in the same direction.  
Die Öffnungen sind in die gleiche Richtung ausgerichtet.  
Les ouvertures sont positionnées dans la même direction.  
Le aperture sono posizionate nella stessa direzione.  
Las aberturas están colocadas en la misma dirección.

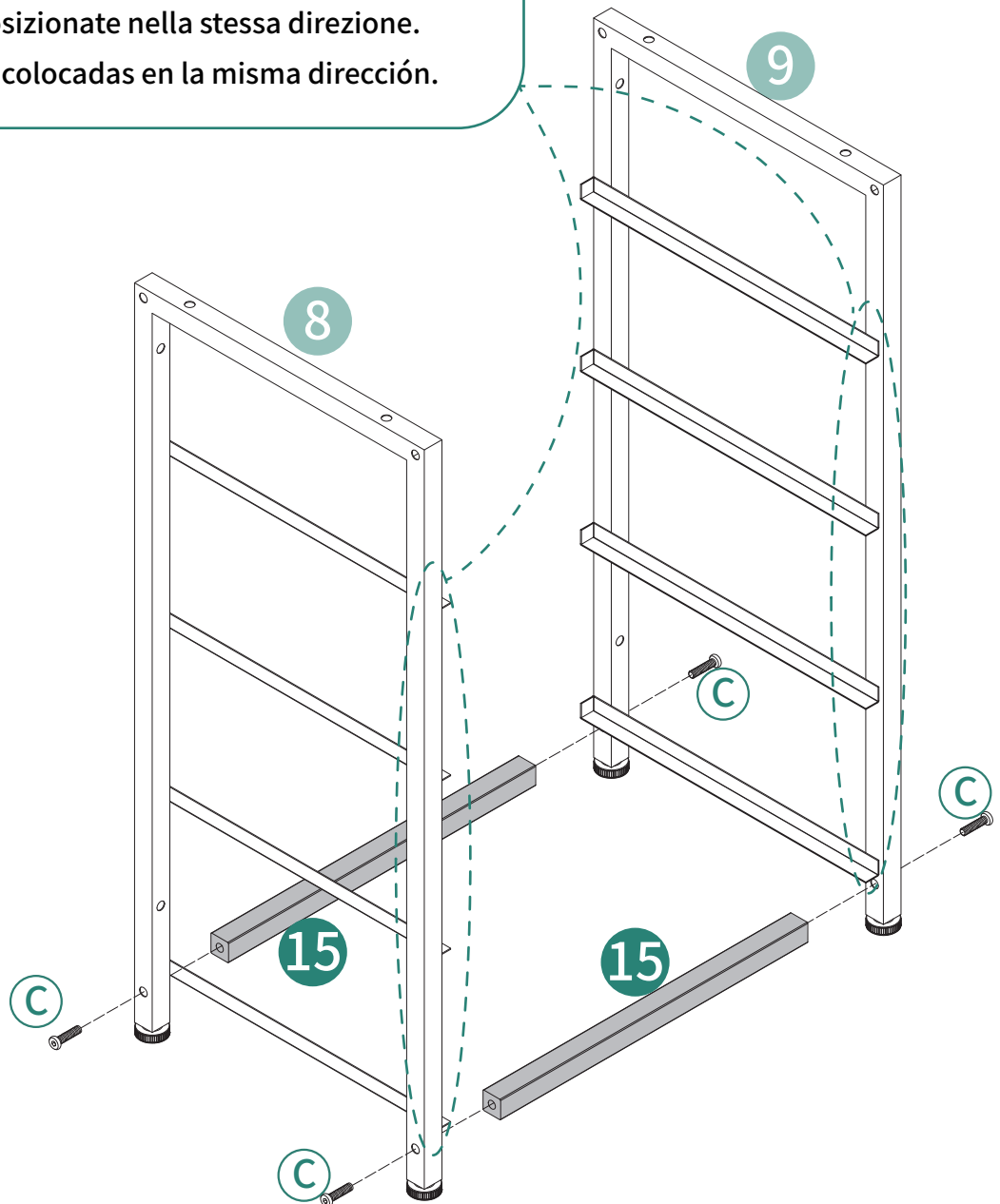

# R4

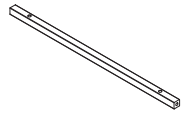

12 1pc

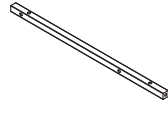

18 1pc



C 4pcs

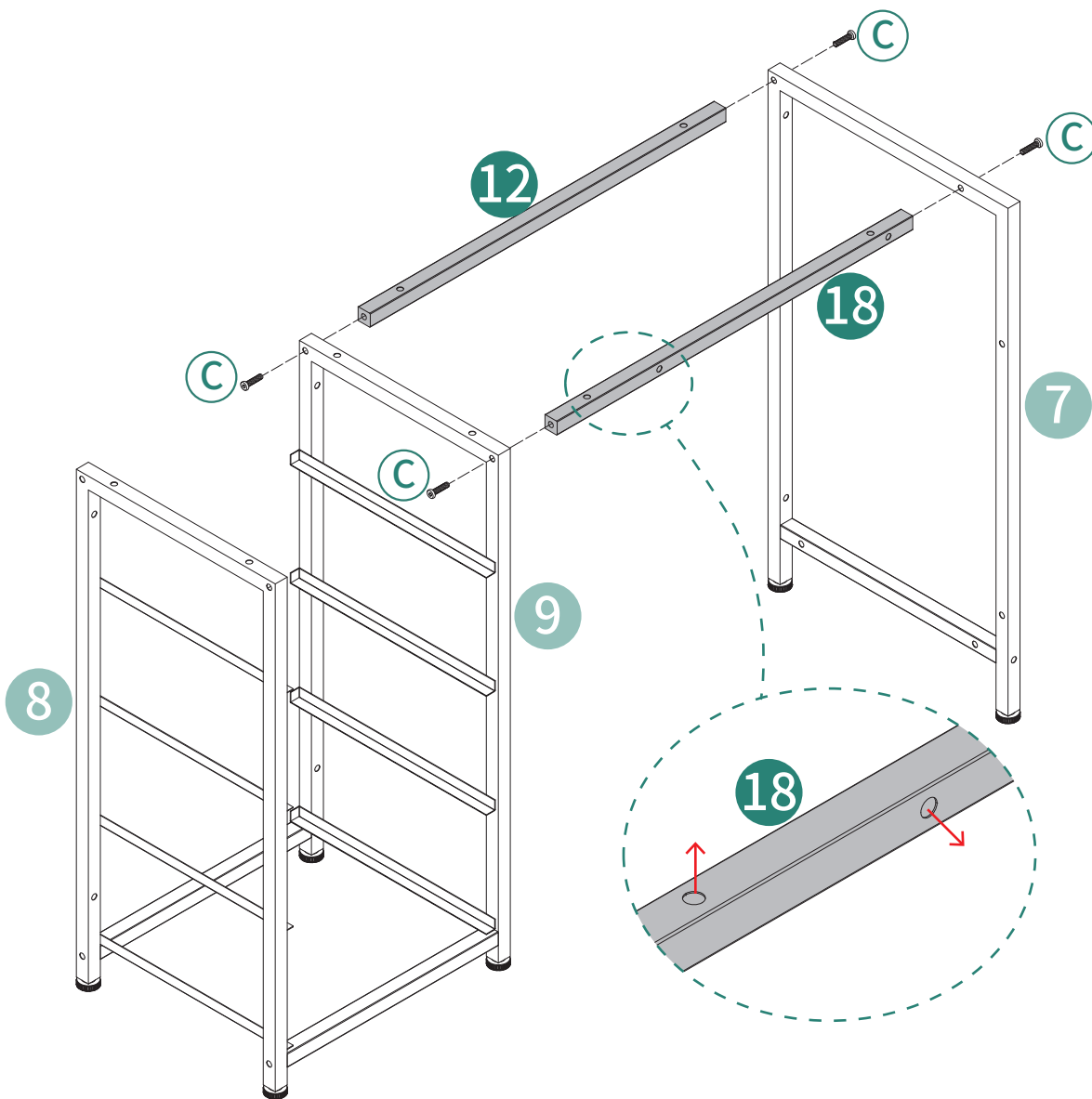

Pay attention to the orientation of the mounting holes during installation.

Achten Sie während der Installation auf die Ausrichtung der Montagelöcher.

Faites attention à l'orientation des trous de montage lors de l'installation.

Prestare attenzione all'orientamento dei fori di montaggio durante l'installazione.

Preste atención a la orientación de los orificios de montaje durante la instalación.

**R5**

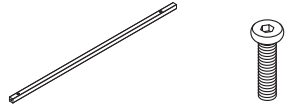

① 12 pcs    ② 4 pcs

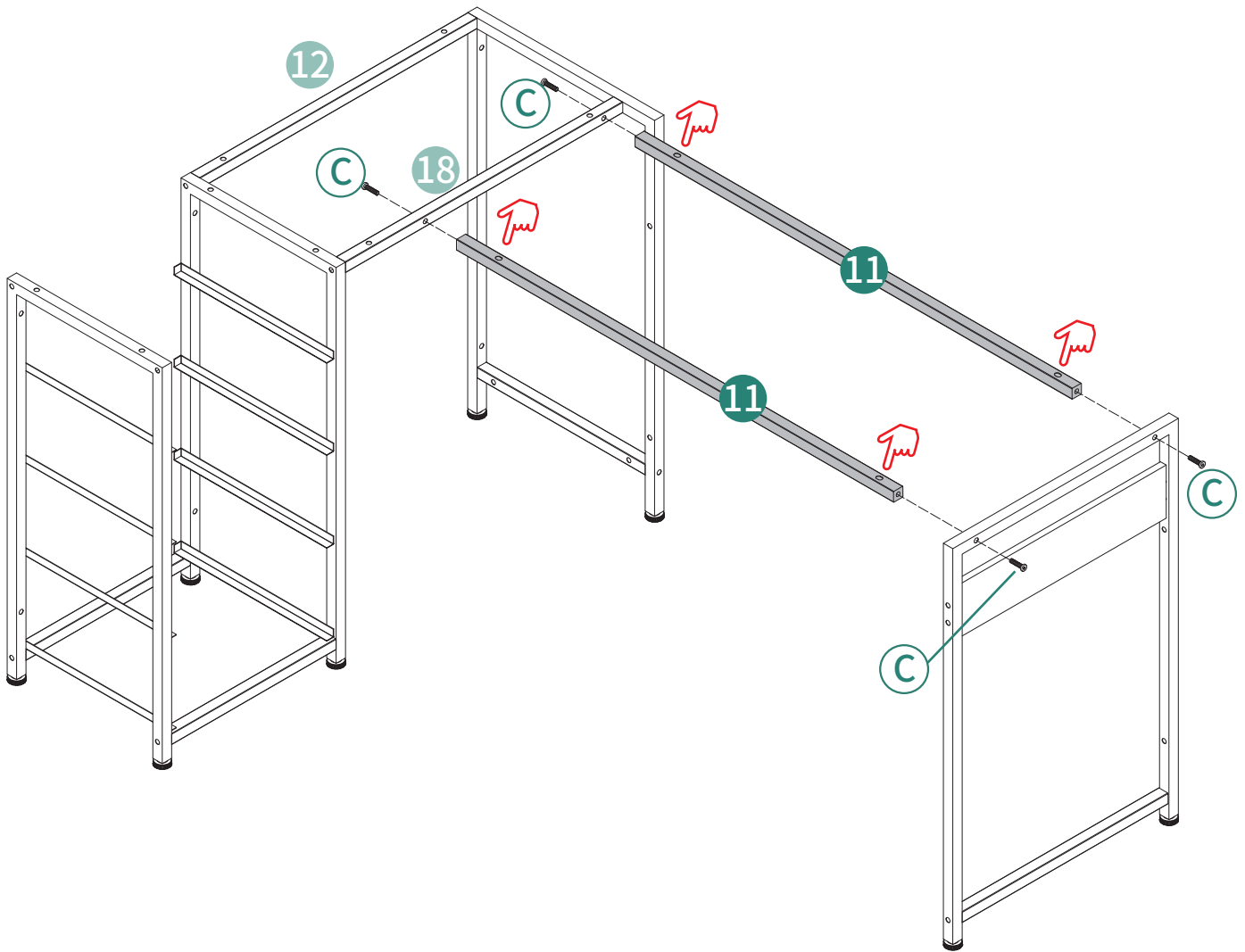

**R6**

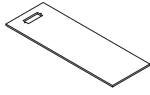

①1pc

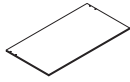

②1pc



Ⓒ12pcs

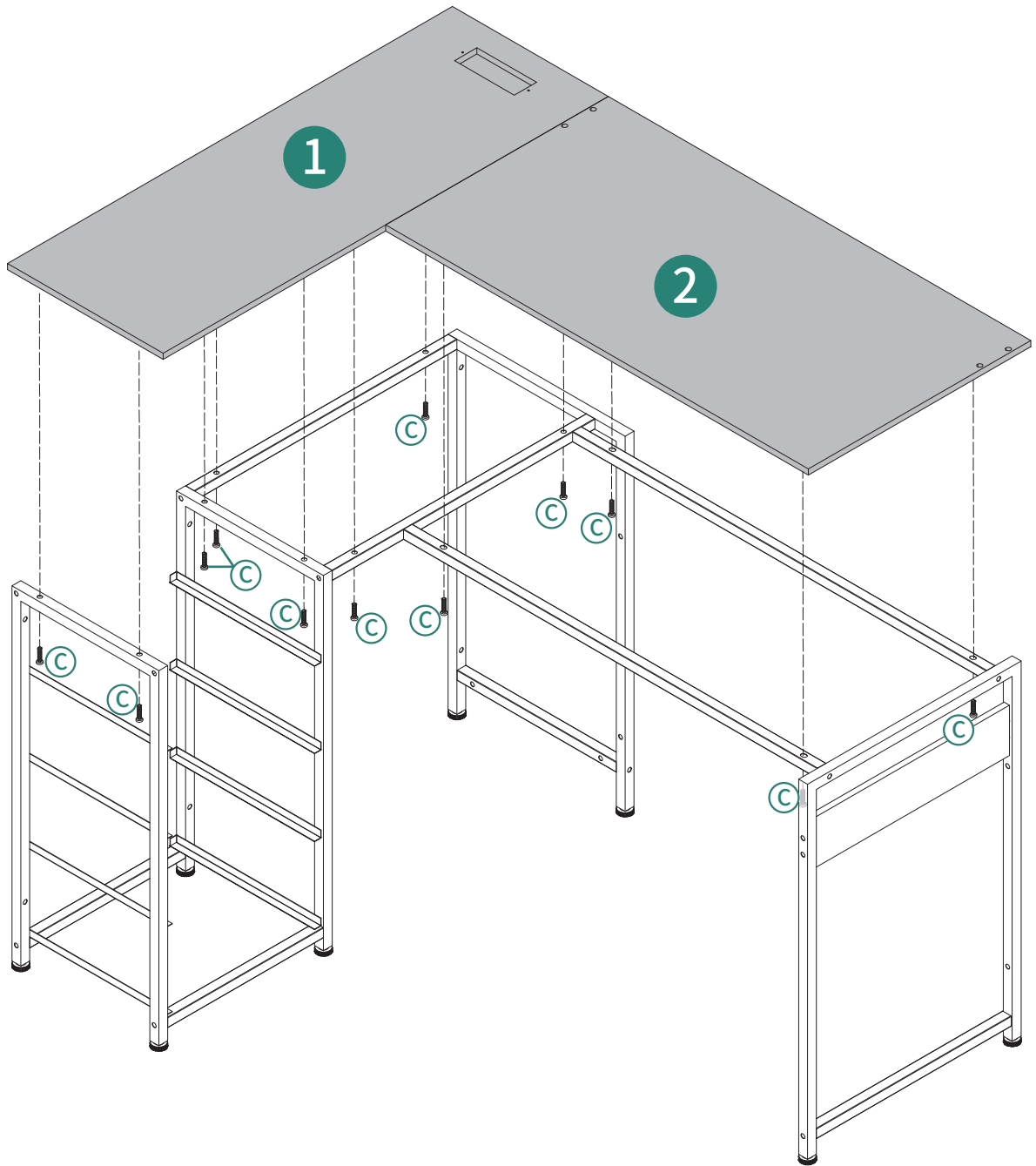

**R7**

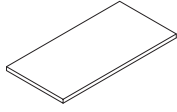

④1pc

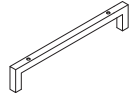

⑩1pc



②2pcs



⑥2pcs

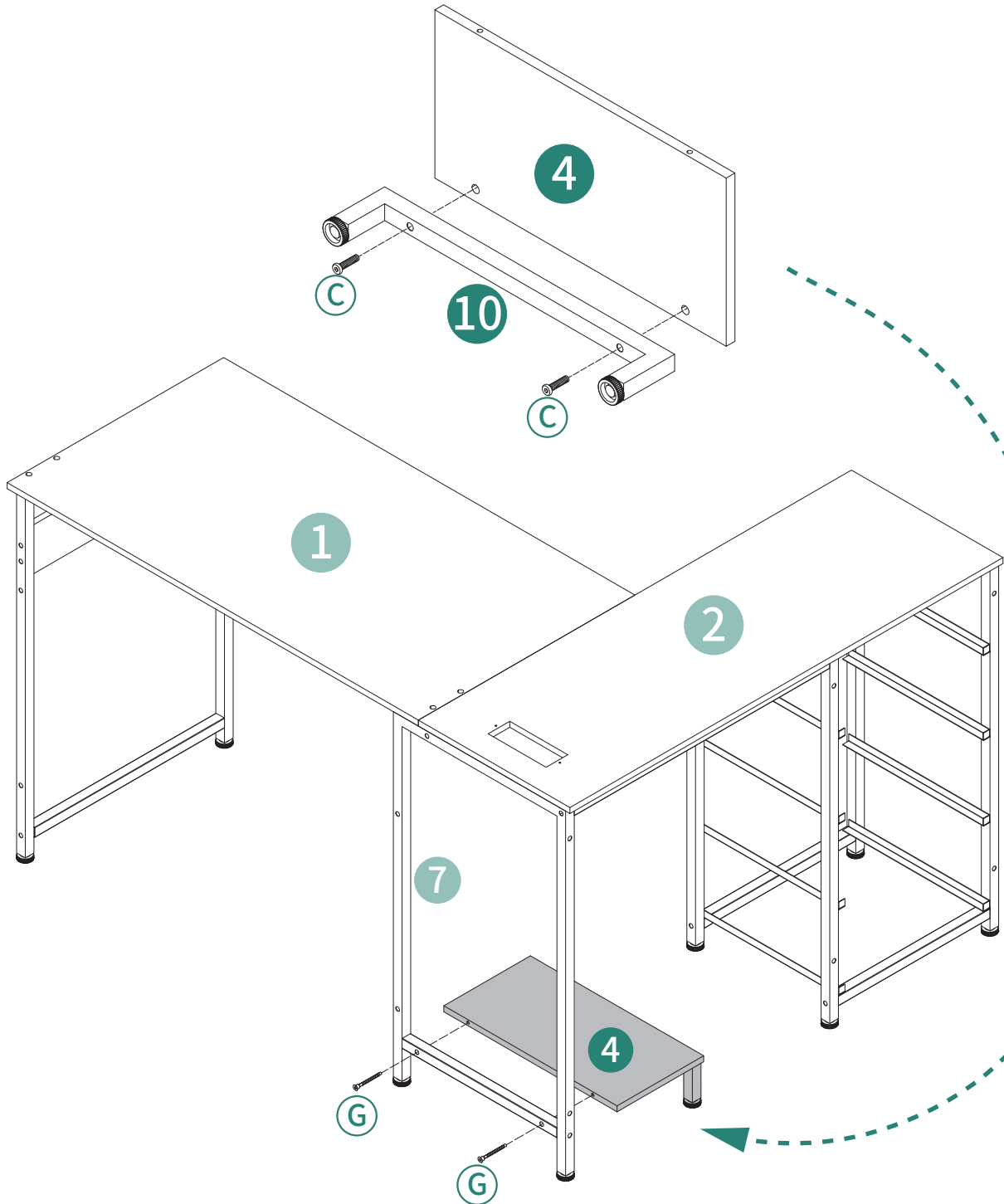

# R8



①9 2pcs



②0 2pcs





Ⓐ 2pcs

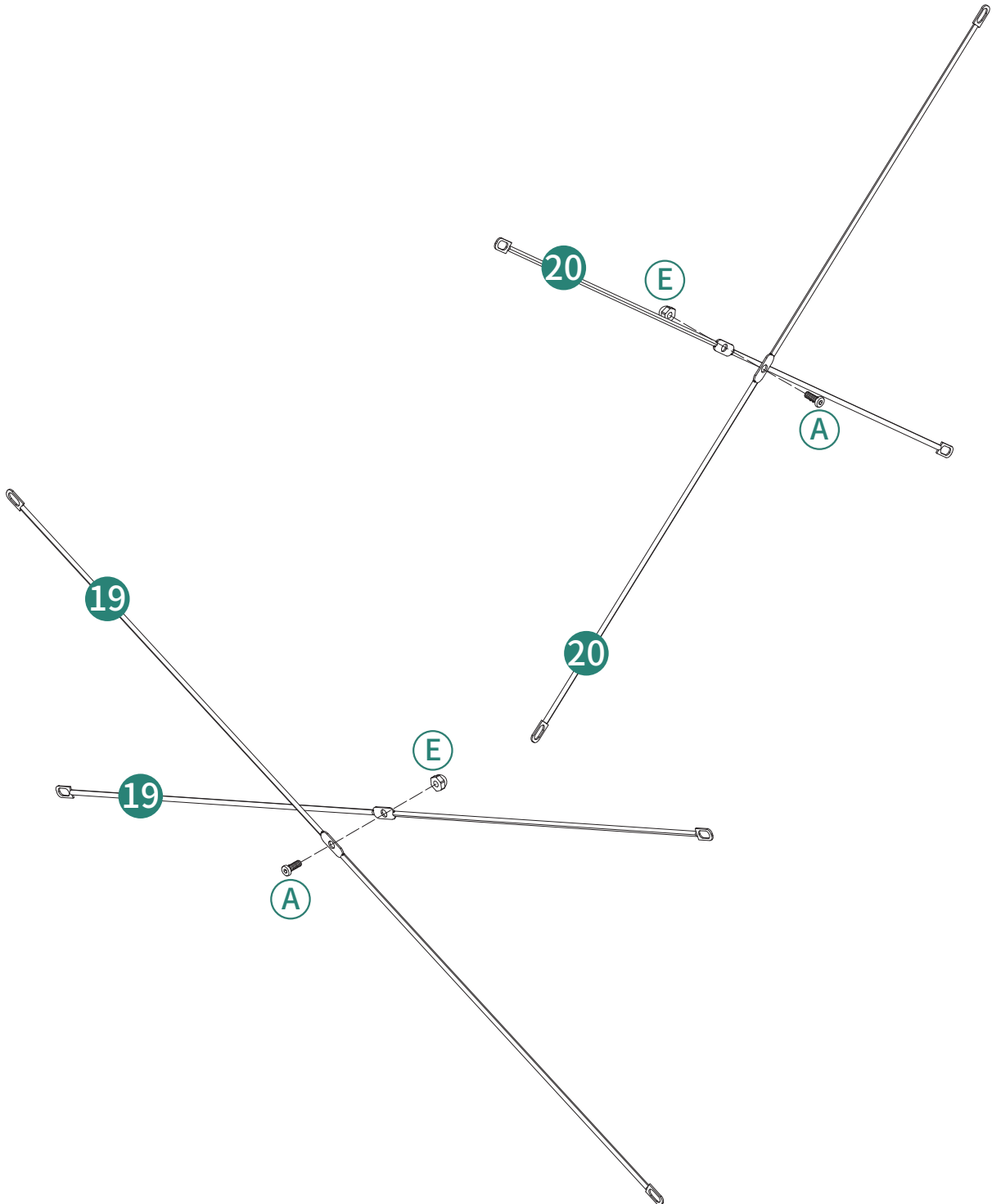

Ⓔ 2pcs



**R9**

ⓐ8pcs    ⓔ8pcs

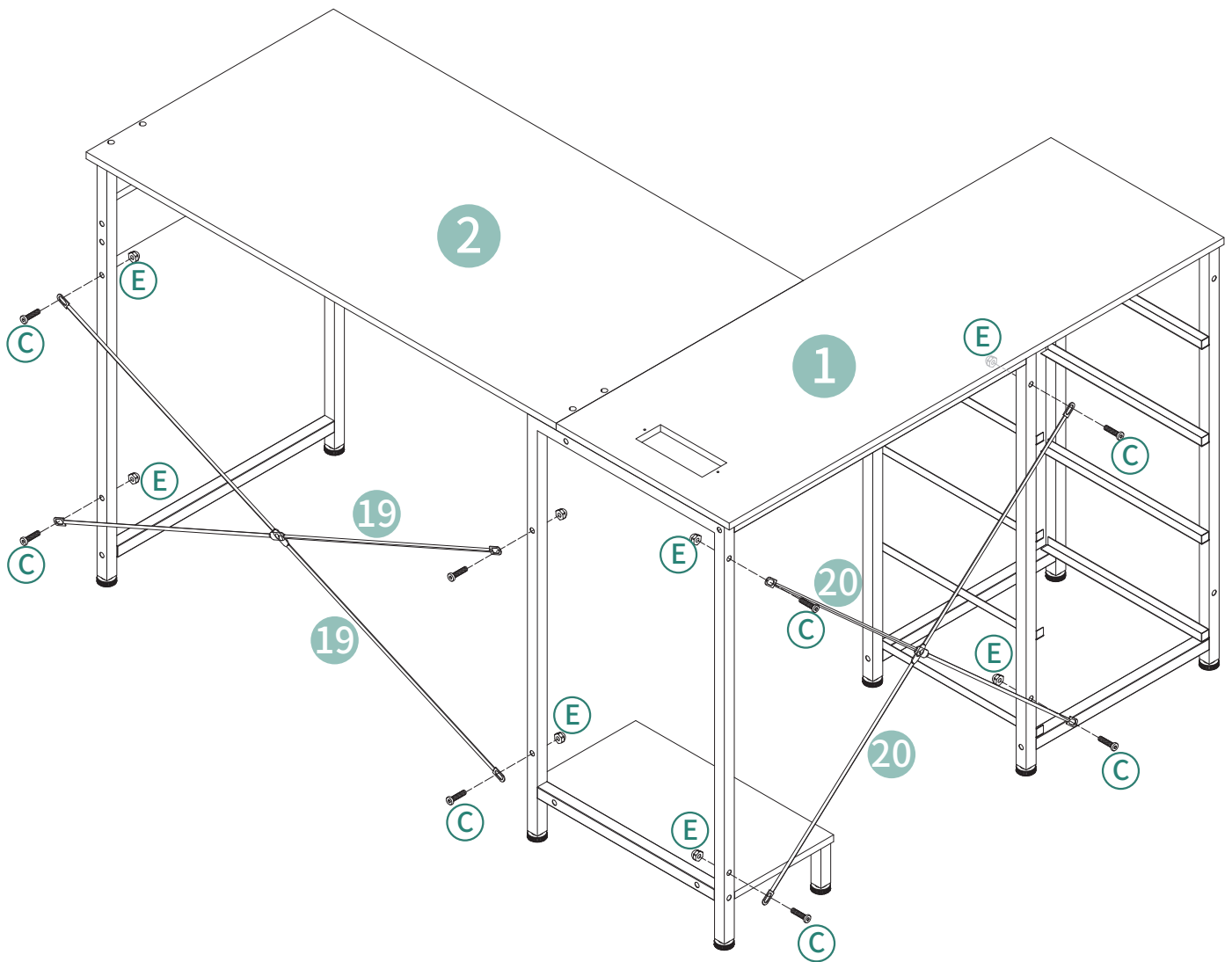

# R10

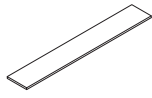

③1pc

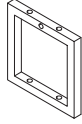

①62pcs

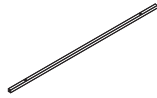

①71pc



①B8pcs

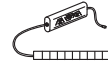

①N1pc

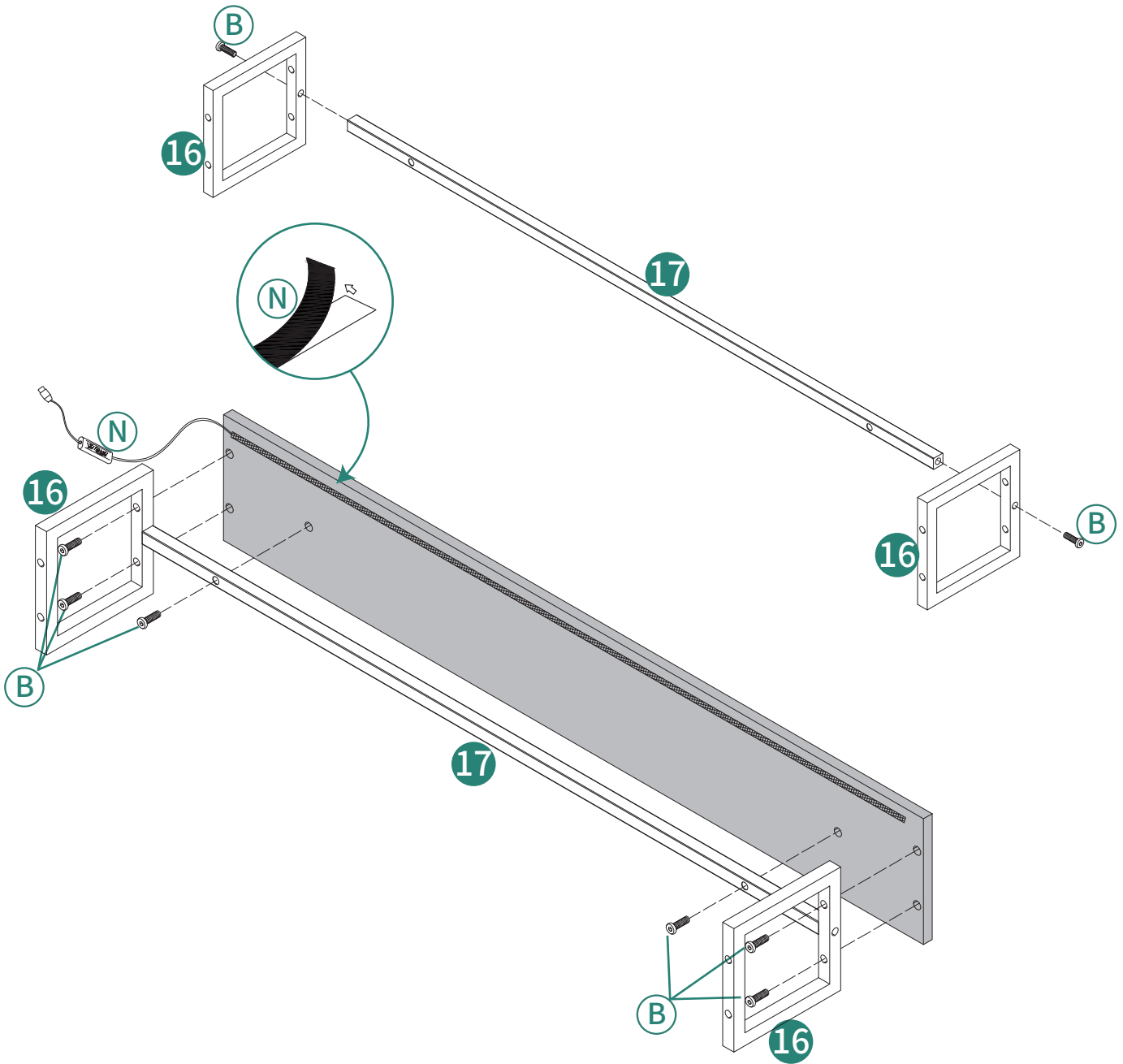

**R11**



ⓑ4pcs

Ensure the N is installed against the wall side.  
Stellen Sie sicher, dass das N gegen die Wandseite installiert ist.  
Assurez-vous que le N est installé contre le côté du mur.  
Assicurati che la N sia installata sul lato del muro.  
Asegúrate de que la N esté instalada contra el lado de la pared.

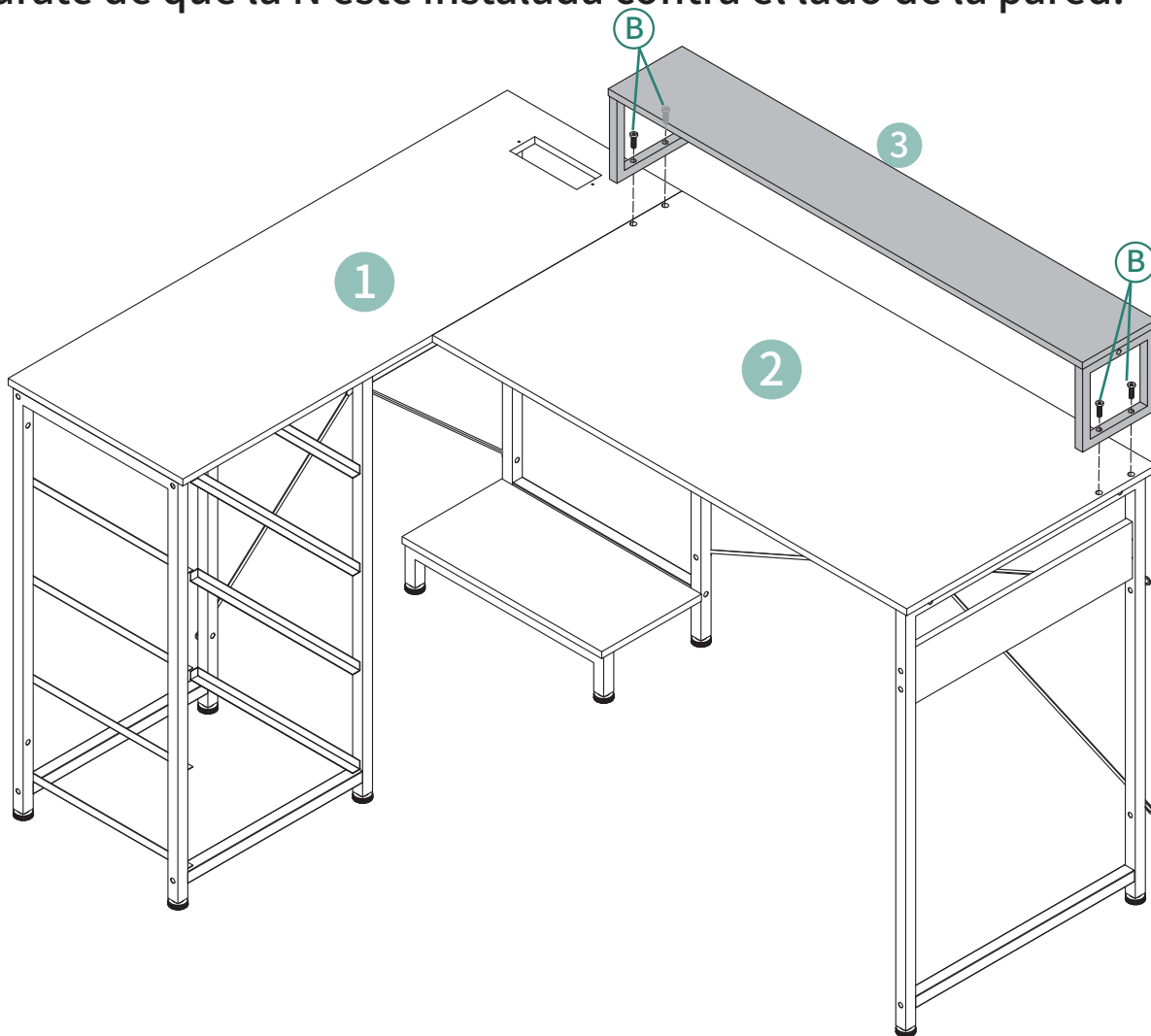

Afix the switch of the light strip in a suitable location.  
Befestigen Sie den Schalter des Lichtstreifens an einem geeigneten Ort.  
Fixez l'interrupteur de la bande lumineuse à un endroit approprié.  
Fissare l'interruttore della striscia luminosa in un luogo adatto.  
Fije el interruptor de la tira de luz en un lugar adecuado.

**R12**

**X4**

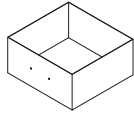

②1 4pcs



②2 4pcs



① 8pcs



① 4pcs

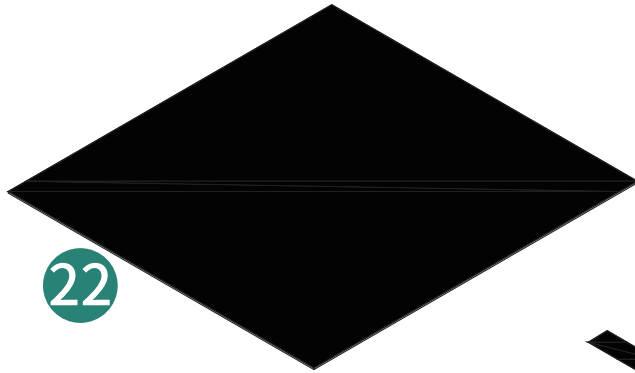

22

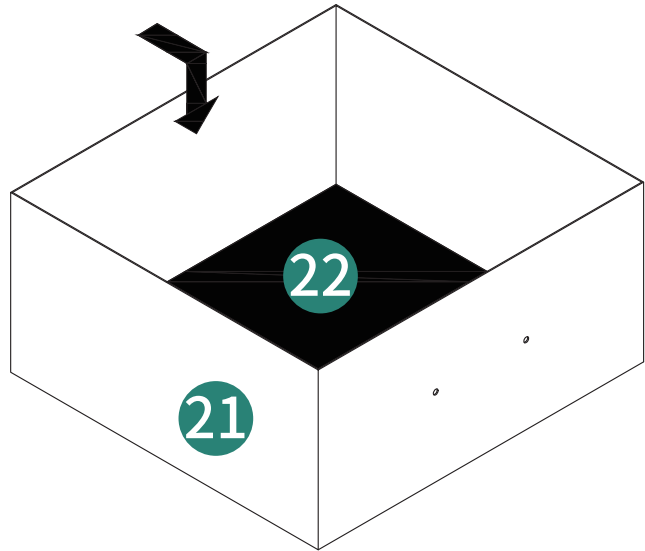

22

21

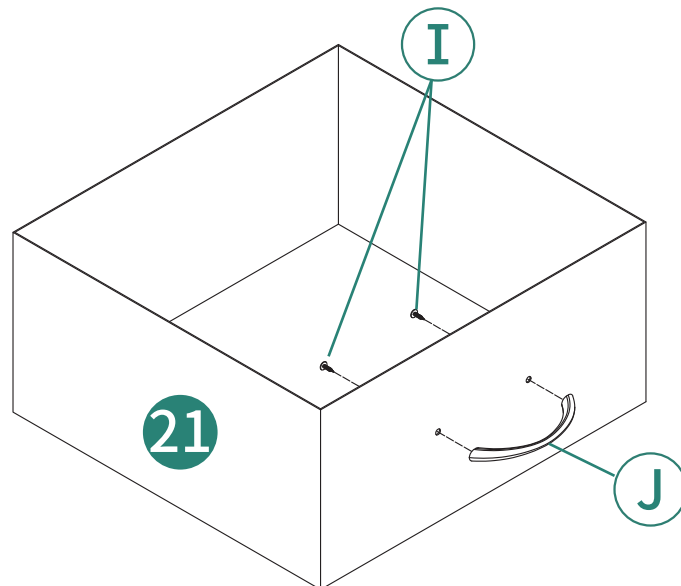

I

21

J

**R13**

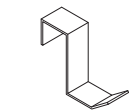

ⓕ2pcs



ⓗ2pcs

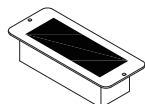

Ⓚ1pc

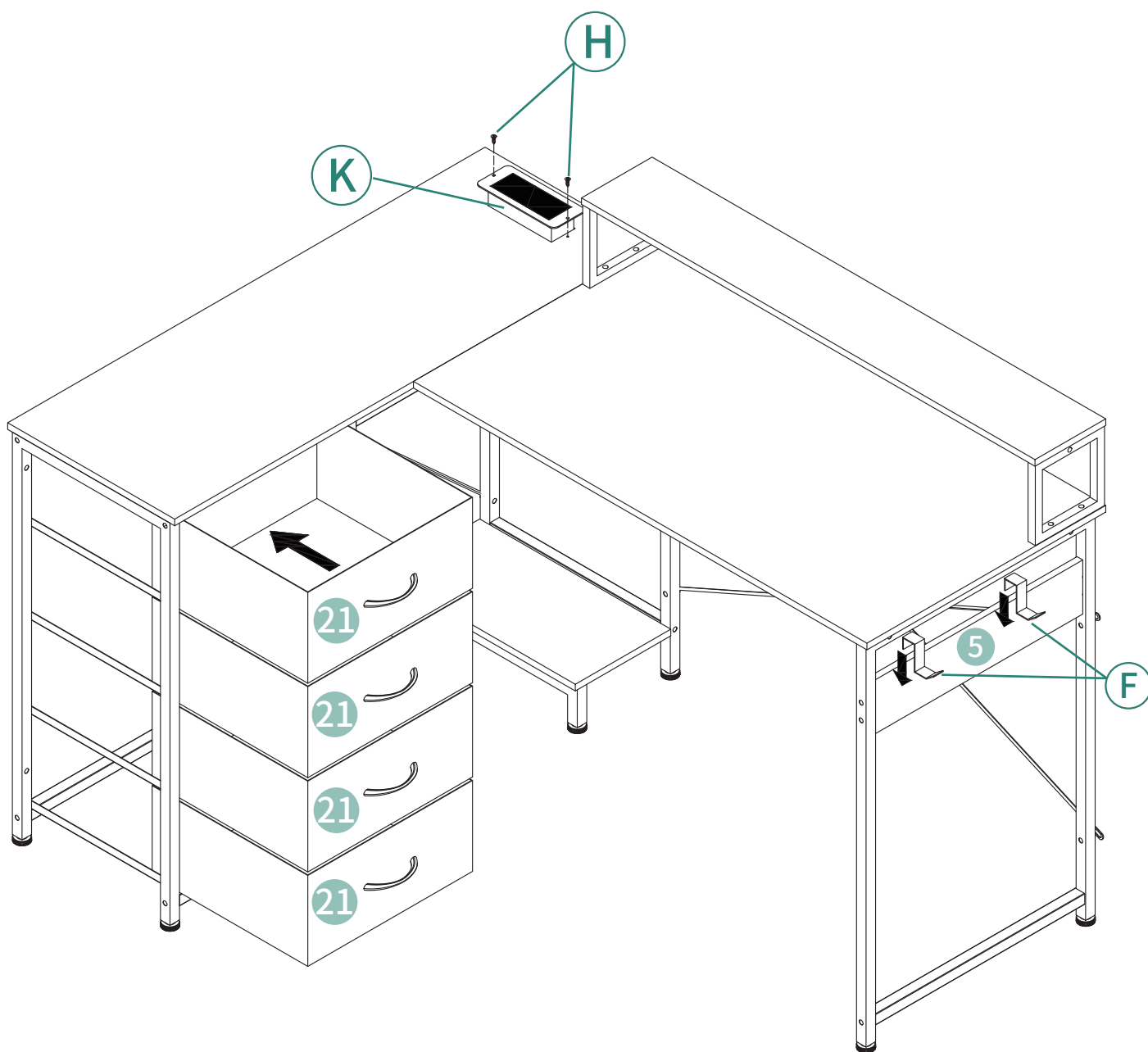

14

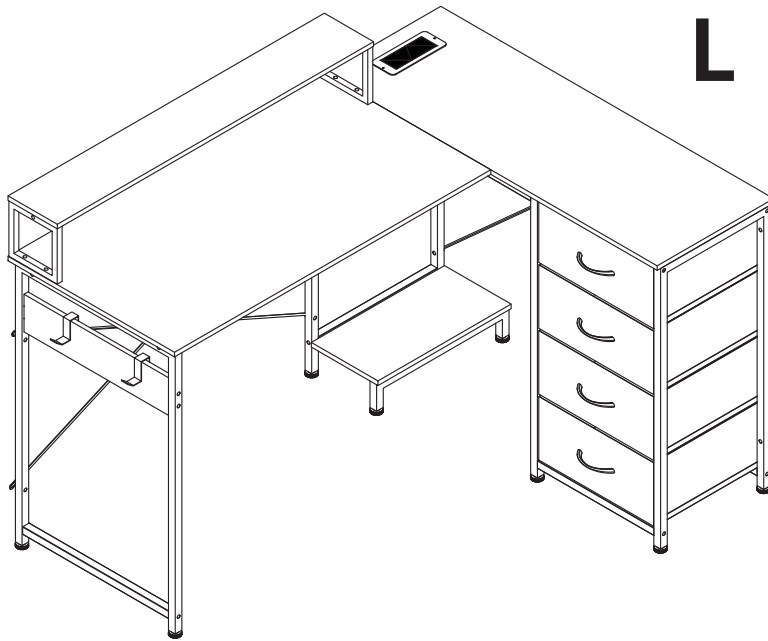

OR

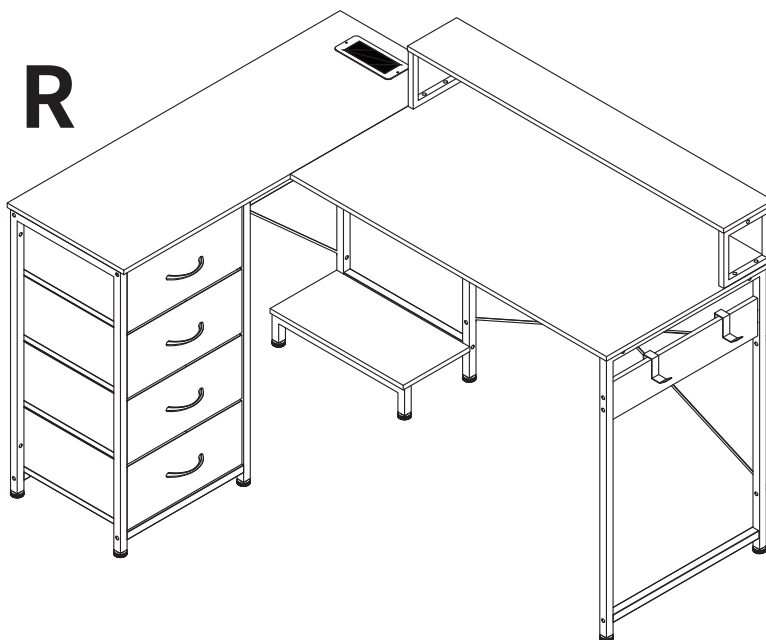

Installation Completed

Installation Abgeschlossen

Installation Complétée

Installazione Completata

Instalación Completada

# HELP CENTER



Inquiry



Assembly issue



Missing parts

If you encounter any difficulties during assembly, please contact us.

Wenn Sie während der Montage auf Schwierigkeiten stoßen, kontaktieren Sie uns bitte.

Si vous rencontrez des difficultés lors du montage, veuillez nous contacter.

Se incontri difficoltà durante il montaggio, ti preghiamo di contattarci.

Si encuentras alguna dificultad durante el ensamblaje, por favor contáctanos.

# DISCLAIMER

Manufacturer and seller expressly disclaim any and all liability for personal injury, property damage or loss, whether direct, indirect, or incidental, resulting from the incorrect attachment, improper use, inadequate maintenance, unapproved modification, or neglect of this product.

Der Hersteller und Verkäufer lehnen ausdrücklich jegliche Haftung für Personenschäden, Sachschäden oder Verluste ab, egal ob direkt, indirekt oder zufällig, die durch falsche Anbringung, unsachgemäßen Gebrauch, unzureichende Wartung, nicht genehmigte Änderungen oder Vernachlässigung dieses Produkts entstehen.

El fabricante y vendedor renuncian expresamente a toda responsabilidad por lesiones personales, daños materiales o pérdidas, ya sean directos, indirectos o incidentales, derivados de la incorrecta colocación, uso inadecuado, mantenimiento insuficiente, modificación no aprobada o negligencia de este producto.

Il produttore e il venditore declinano espressamente ogni responsabilità per lesioni personali, danni materiali o perdite, dirette, indirette o incidentali, derivanti dall'errato fissaggio, uso improprio, manutenzione inadeguata, modifica non autorizzata o negligenza di questo prodotto. Le fabricant et le vendeur déclinent expressément toute responsabilité en cas de blessures corporelles, de dommages matériels ou de pertes, qu'ils soient directs, indirects ou accessoires, résultant de la fixation incorrecte, de l'utilisation inappropriée, de l'entretien insuffisant, de la modification non approuvée ou de la négligence de ce produit.