

INSTRUCTION MANUAL ENCLOSED

ATTENTION

IF YOU HAVE ANY PROBLEMS OR QUESTIONS, EMAIL OR CALL CUSTOMER SERVICE BEFORE YOU RETURN THIS PRODUCT TO THE STORE WHERE IT WAS PURCHASED.







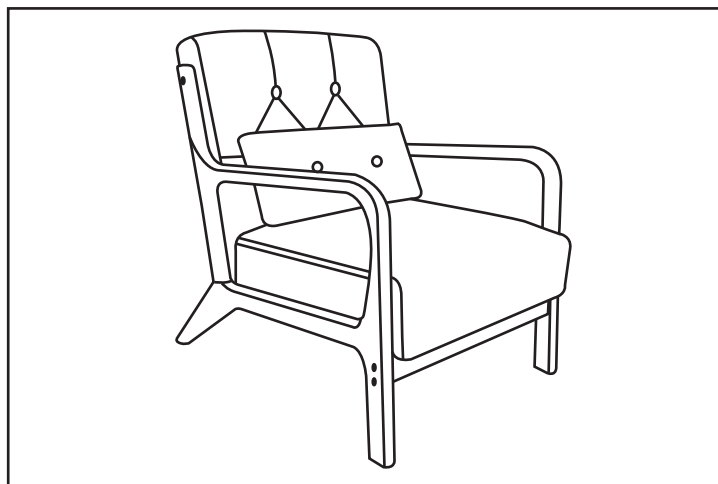



**When emailing Customer Service, please include your Order Number and platform of purchase in the email subject for quicker assistance.

INSTRUCTION MANUAL ENCLOSED

INDOOR ACCENT CHAIR INDOOR ACCENT CHAIR ASSEMBLY INSTRUCTION



Part	PARTS LIST	Quantity
A	Right Arm	1
B	Left Arm	1
C	Seat Cushion	1
D	Back Cushion	1
E	Front Stretcher	1
F	Cushion	1
	HARDWARE	
a	Bolts(M8*60MM)	10
b	Big flat washers	2
c	Allen Wrench	1
d	Felt Pad	4

Item	Description	QTY	Item	Description	QTY
A	 Ⓜ	1	a		10
B	 Ⓜ	1	b		2
C		1	c		1
D		1	d		4
E		1			
F		1			

PLEASE READ AND FOLLOW ALL SAFETY TIPS

GETTING STARTED

1. Before assembly, **CAREFULLY** use scissors or utility knife to cut and unwrap all parts. Make sure you do not discard the hardware.
 2. Make sure that you have all the parts listed. If you are missing any parts, please contact Customer Service:
Please identify the parts you need and model number. Make sure to include your name and address.
 3. Please include your Order Number and platform of purchase in the email subject, and one of our customer service representative will get back to you.
- Warm Tips:**
1. The plastic covers on some metal parts are just for product protection. Please remove it before assembly.
 2. Please follow the sequence of AI during assembly.
 3. Do not tighten the screws until all of them are in right positions.

Step 1. Assemble the lounge on a flat, soft surface such as a carpet or cloth to prevent scratching the finish. Open the bottom covering, then loosely attach seat cushion (C) to back cushion (D) using bolts (a), lock washers (b) . Loosely tighten by Allen wrench (c) .

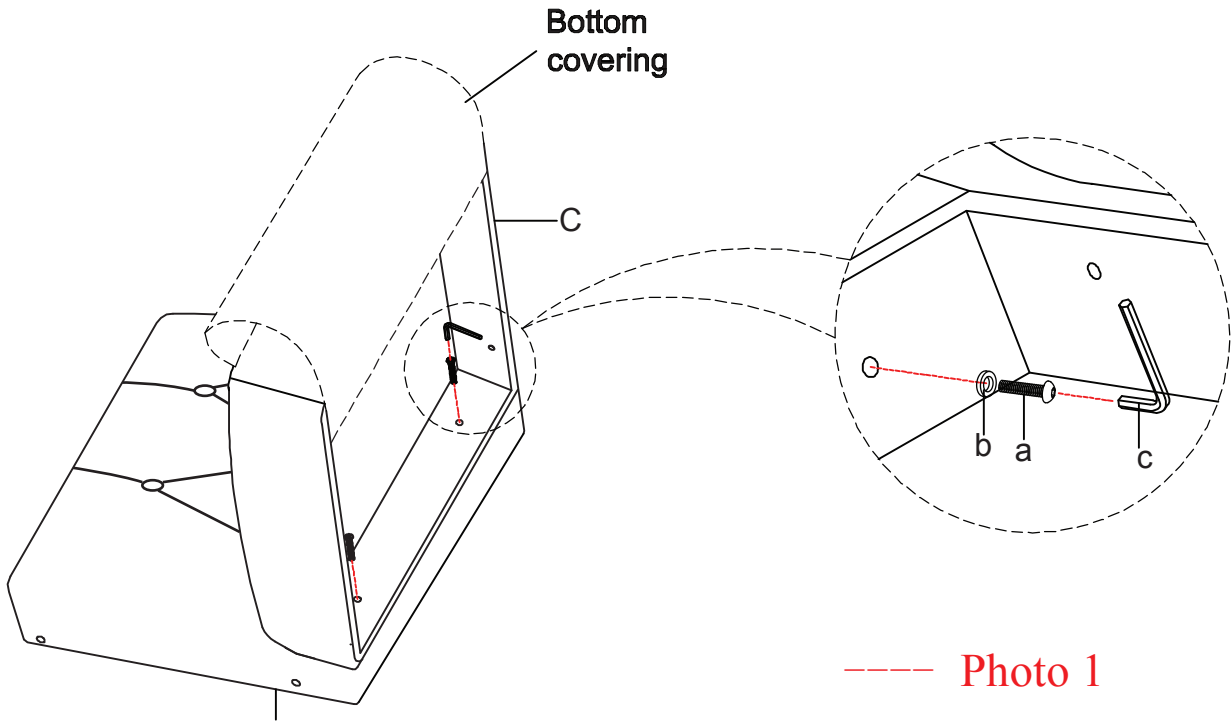

D

Step 2. Attach right arm (A) to seat cushion (C) and back cushion (D) using bolts (a), lock washers (b) according to the label "R" on the right arm (A) and the side of seat cushion (C) and back cushion (D). Loosely tighten by Allen wrench (c) as shown below.

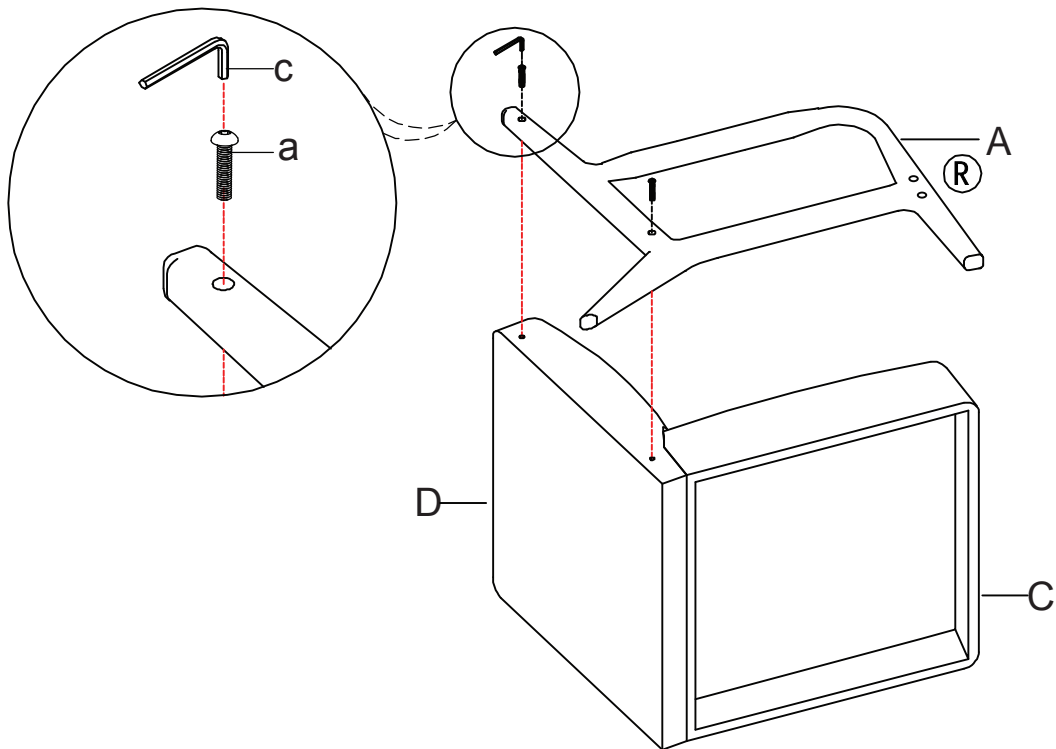

----- Photo 2

Step 3. Insert front stretche(E) to right arm(A) with two located dowels. Note:the front stretcher(E) with screw holes should be face down. Attach left arm (B) to the front stretcher(E),seat cushion(C) and back cushion(D) using bolts(a),lock washers(b) according to the label "L" on the left arm(B) and the side of seat cushion(C) and back cushion(D).Securely tighten all bolts by Allen wrench(c).

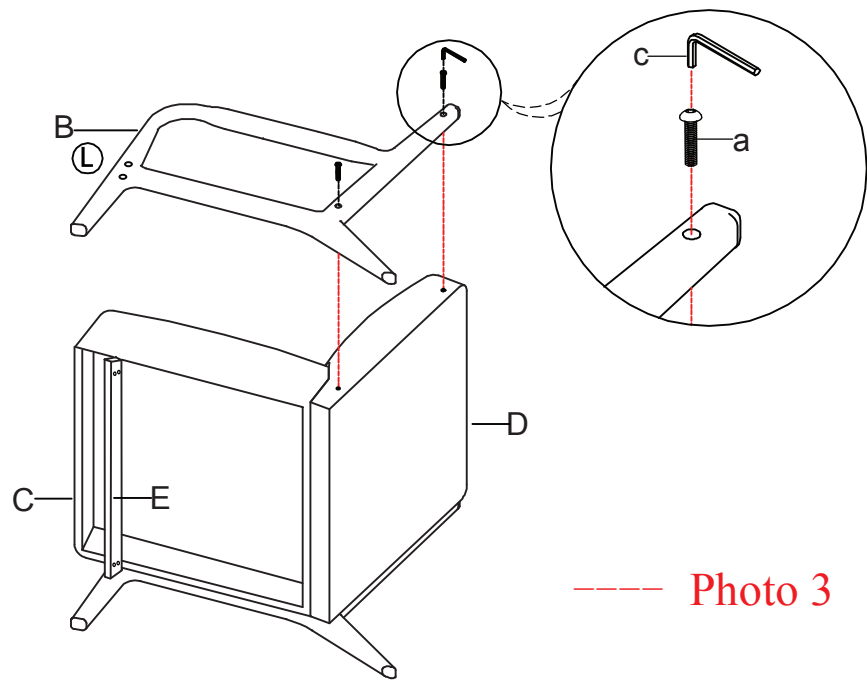

----- Photo 3

Step 4. Tighten bolts(a) through the front stretcher(E) to the right arm (A) and left arm (B) with Allen wrench (c).

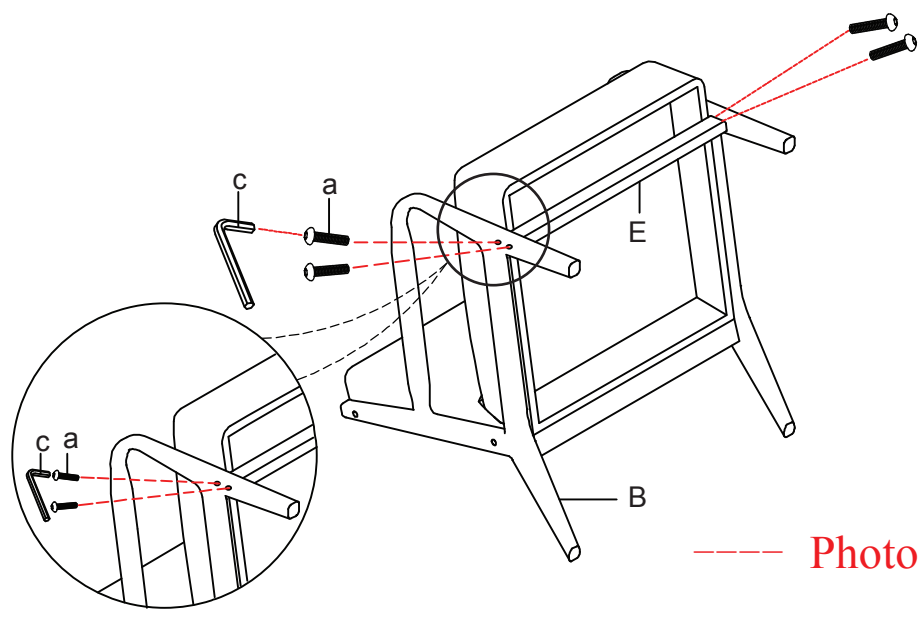

----- Photo 4

Step 5. Securely tighten all bolts by Allen wrench(c). Attach wooden plugs (d) to each bolt hole, tighten with rubber hammer to knock the wooden plug till its tighten. Note:use a soft cloth between the wooden plug and hammer to prevent damage to woden plug finish. Assembly is complete.

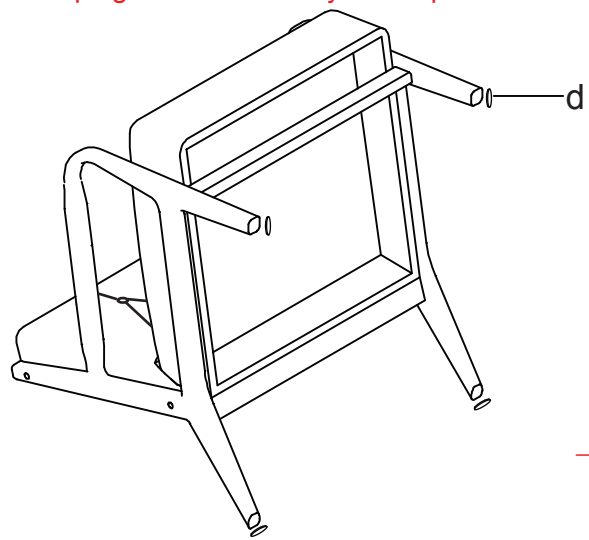

----- Photo 5