

STORAGE DESK

Instruction manual

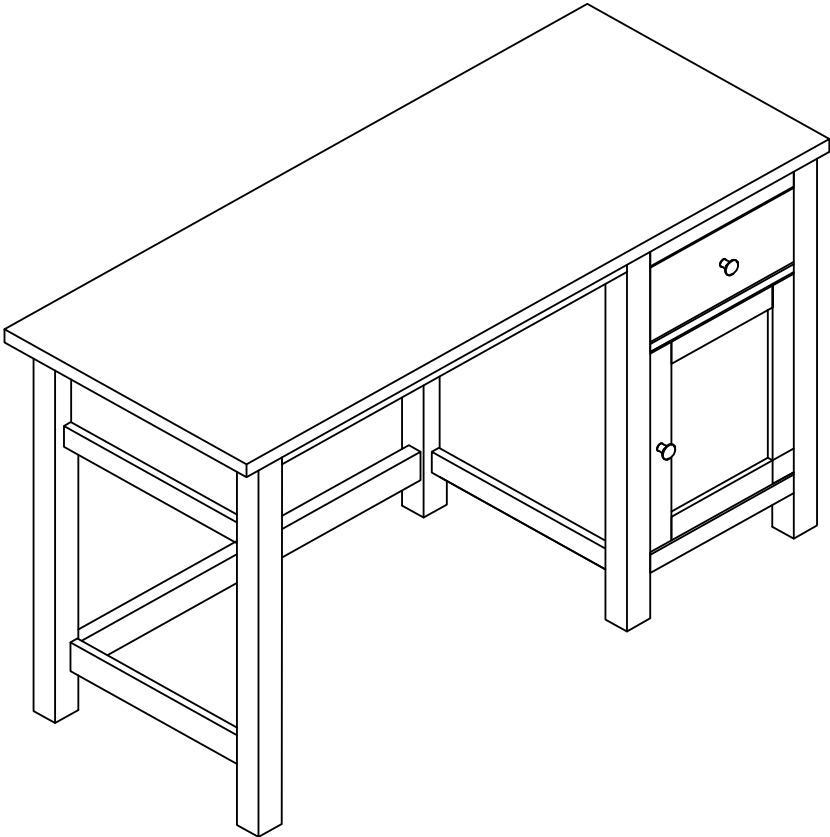



SAFETY AND CARE ADVICE

PLEASE READ THESE INSTRUCTIONS CAREFULLY AND KEEP FOR FUTURE

- *Check you have all the components and tools listed on pages 2 or 3.*
- *Remove all fittings from the plastic bags and separate them into their groups.*
- *Keep children and animals away from the work area, small parts could choke if swallowed.*
- *Make sure you have enough space to layout the parts before starting.*
- *Do not stand or put weight on the product, this could cause damage.*
- *Assemble on a soft level surface to avoid damaging the unit or your floor (use opened out unit carton).*
- *We do not recommend the use of power drill/drivers for inserting screws, as this could damage the unit. Only use hand screwdrivers.*

COMPONENTS — PANELS

Please check you have all the panels listed below:

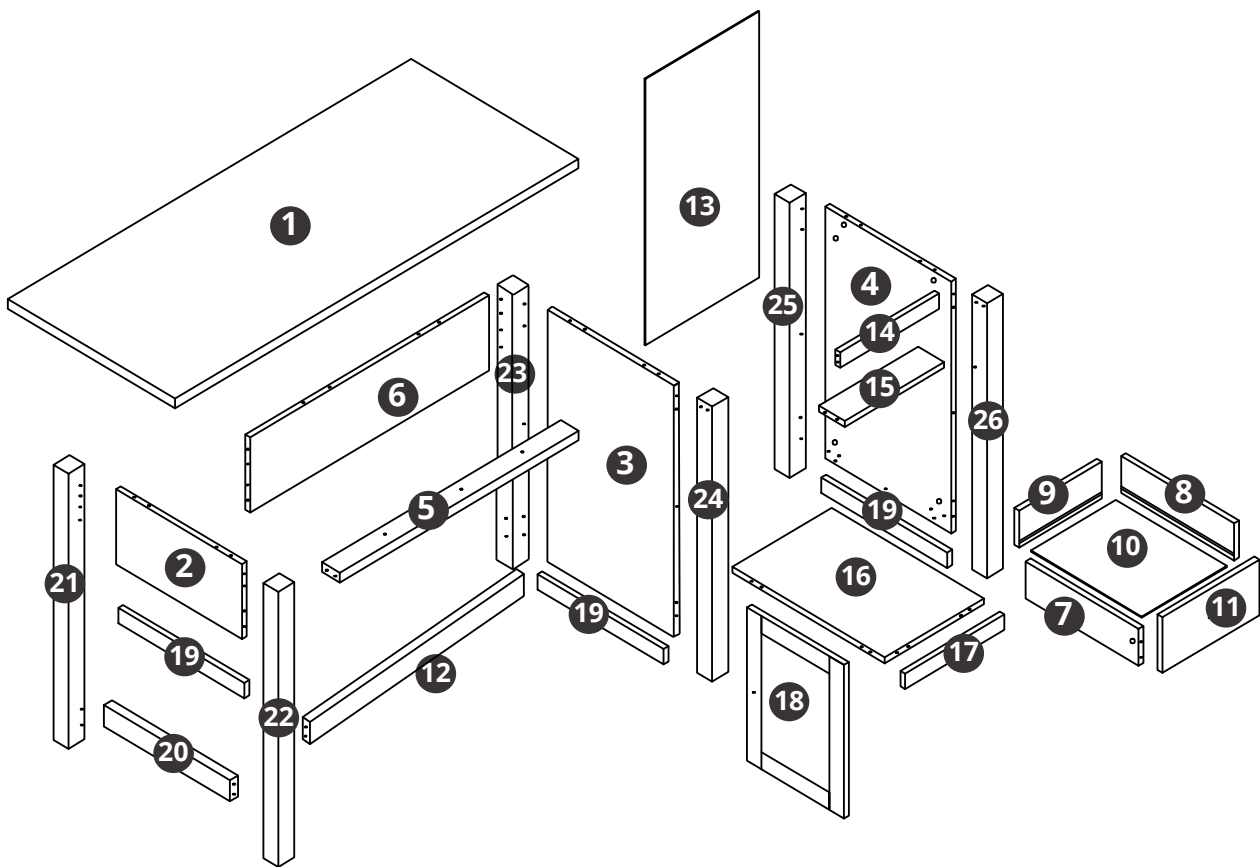

PANEL LIST

1	Top Panel	x1	14	Upper Cross Bar	x1
2	Left Side Panel	x1	15	Middle Cross Bar	x1
3	Right Middle Panel	x1	16	Base Panel	x1
4	Right Side Panel	x1	17	Lower Cross Bar	x1
5	Front Cross Bar	x1	18	Door Panel	x1
6	Back Support Panel	x1	19	Side Cross Bar	x3
7	Drawer Left Side Panel	x1	20	Left Support Bar	x1
8	Drawer Right Side Panel	x1	21	Left Back Frame	x1
9	Drawer Back Panel	x1	22	Left Front Frame	x1
10	Drawer Base Panel	x1	23	Middle Back Frame	x1
11	Drawer Front Panel	x1	24	Middle Front Frame	x1
12	Back Support Bar	x1	25	Right Back Frame	x1
13	Back Panel	x1	26	Right Front Frame	x1

COMPONENTS — FITTINGS

Please check you have all the fittings listed below:



Peg M6*35mm x50



Lock M15*12mm x50

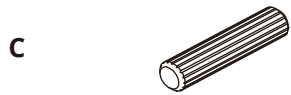

Dowel M8*30mm x38



Handles x2



Screw M4*40mm x7



Screw M3.5*12mm x24



Pin x24



Plastic Feet x6

CR CL DR DL

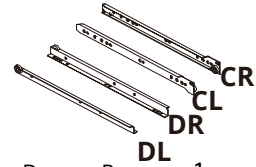

Drawer Runner x1



Safety Device x2



Screw M4*20mm x2



Screw M4*25mm x9



Full Overly Door Hinge x2



Plastic Stopper x1



Hole cover x23

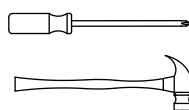

TOOLS NEEDED
(We don't provide)



Phillips Screwdriver x 1
Hammer x 1



ASSEMBLY INSTRUCTIONS

Step 1

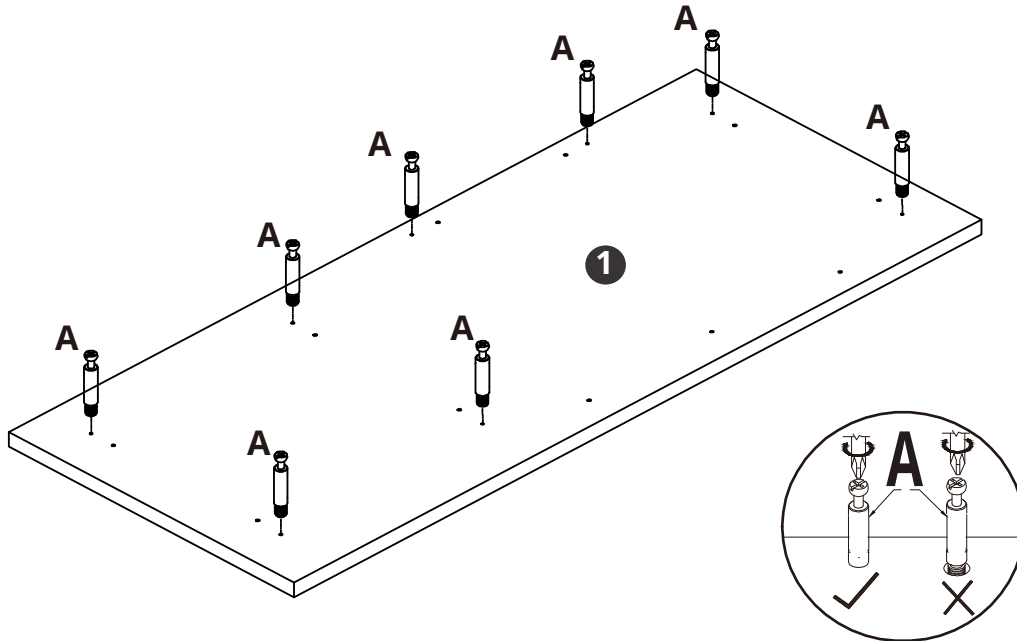
A		8	
---	--	---	---



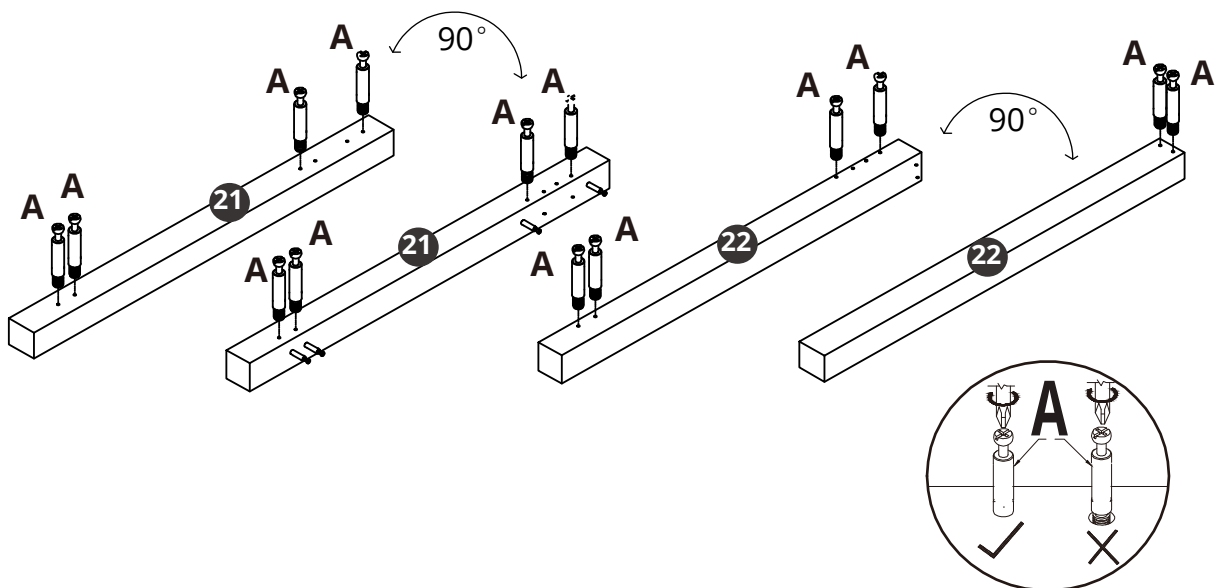

Step 2

A		14	
---	--	----	---





ASSEMBLY INSTRUCTIONS

Step 3

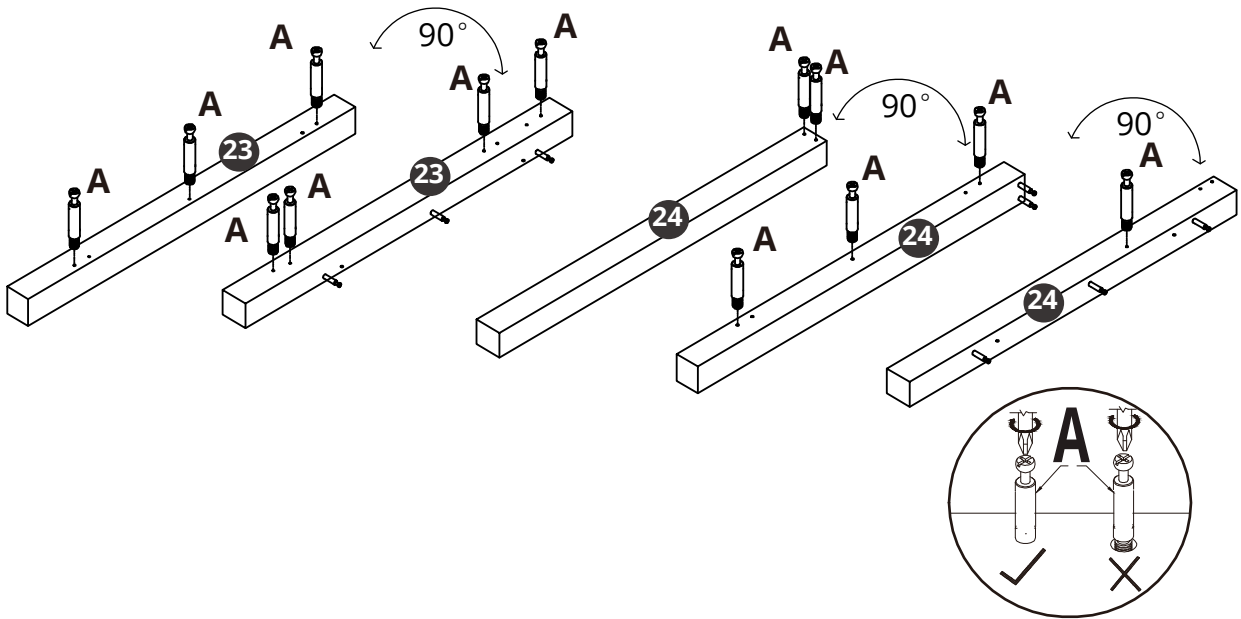
A		13	
---	--	----	---



Step 4

A		7	
---	--	---	---

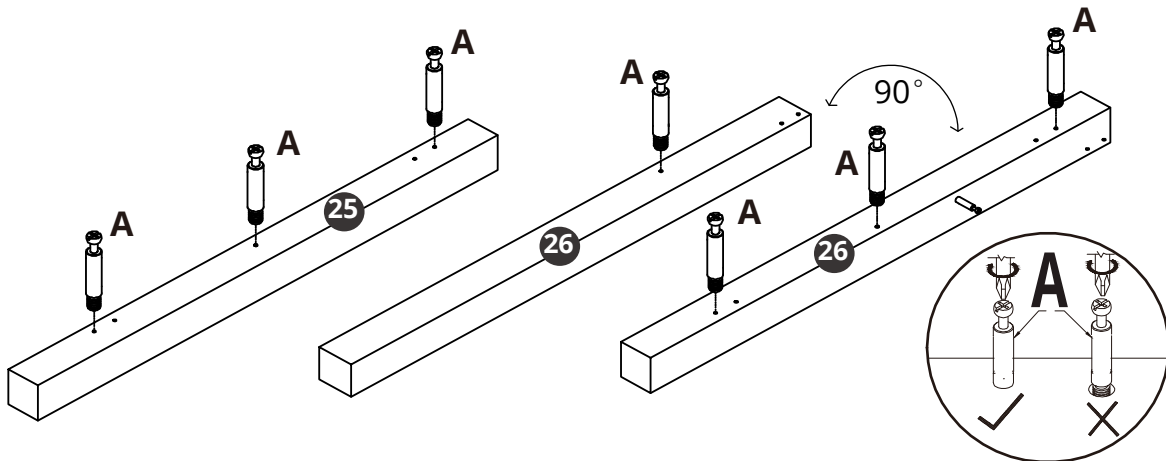

ASSEMBLY INSTRUCTIONS

Step 5

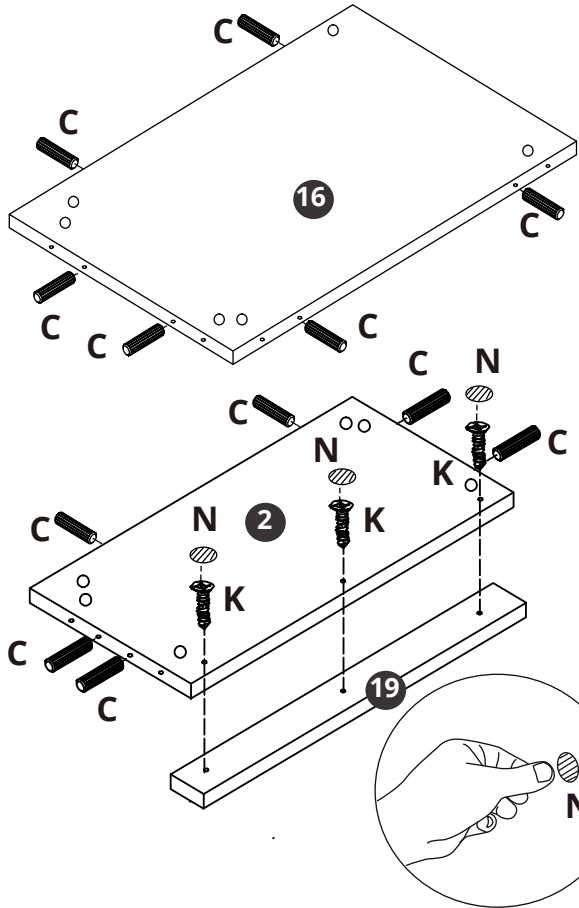

A		2	
C		16	
K		3	
N		3	

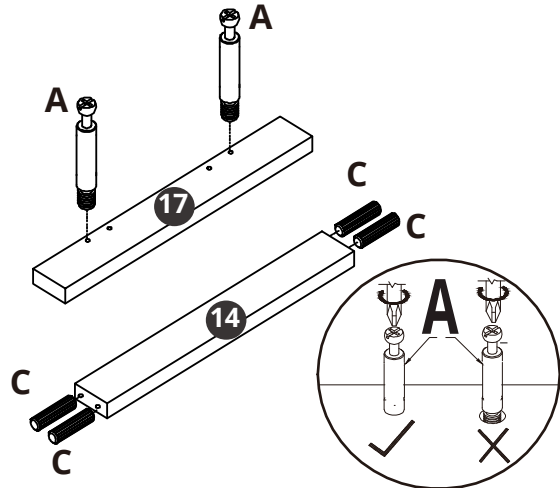

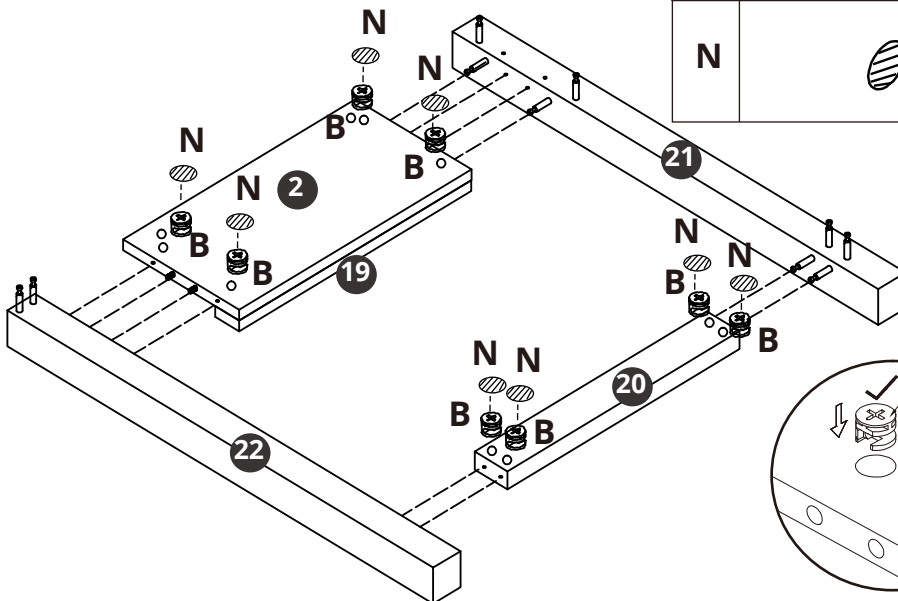

Step 6



B		8	
N		8	



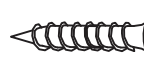

ASSEMBLY INSTRUCTIONS

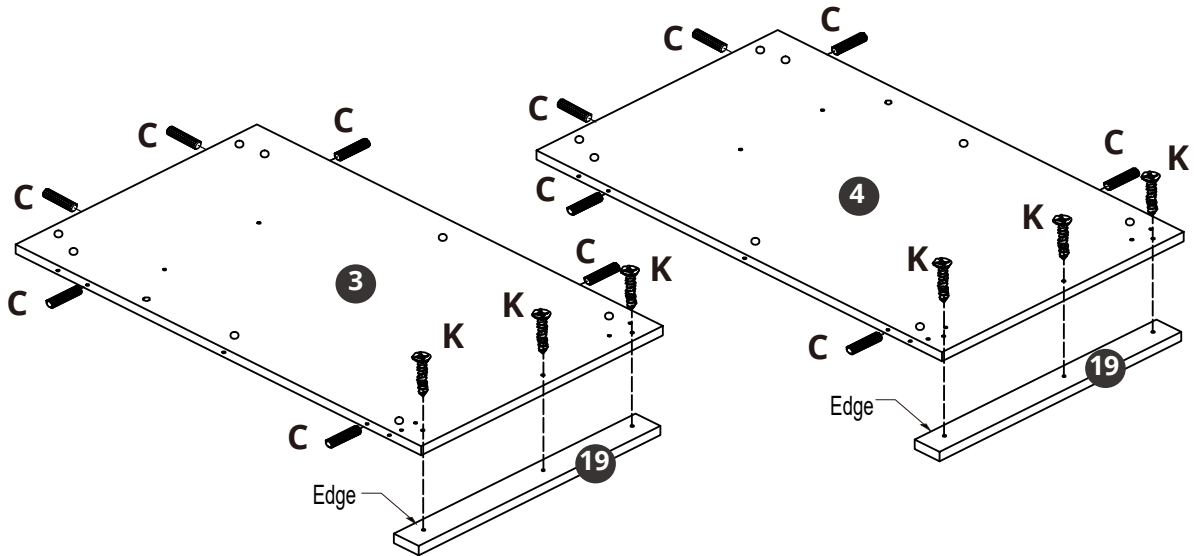
Step 7

C		12	
K		6	



Step 8

A		2	
B		6	

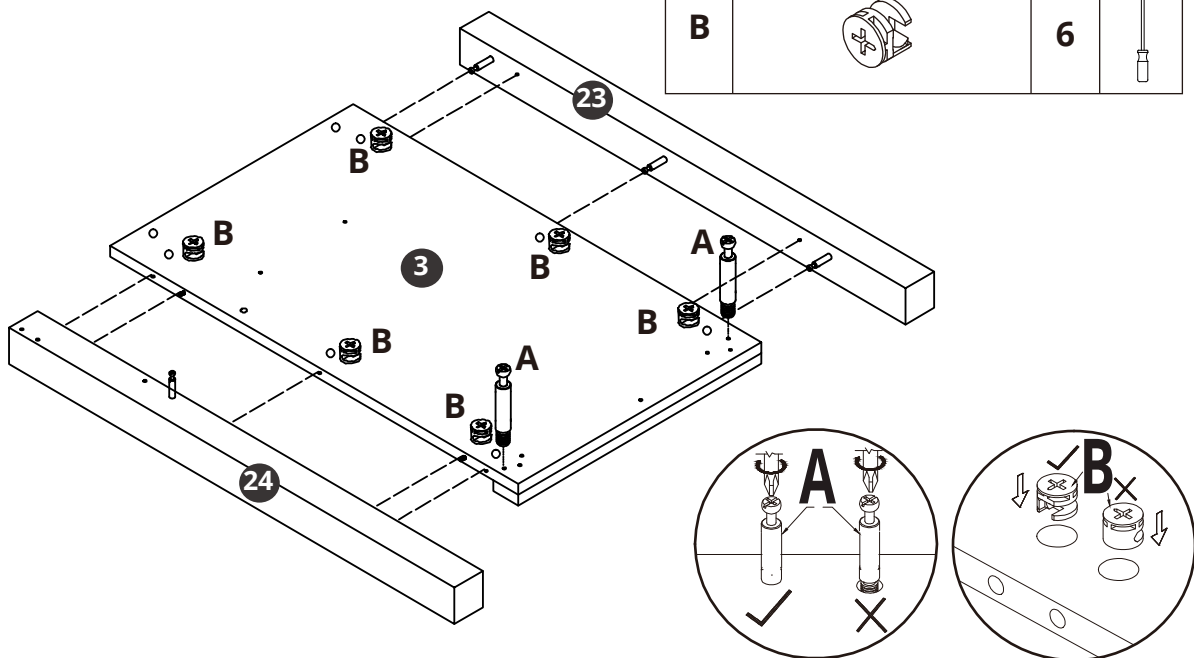

ASSEMBLY INSTRUCTIONS

Step 9

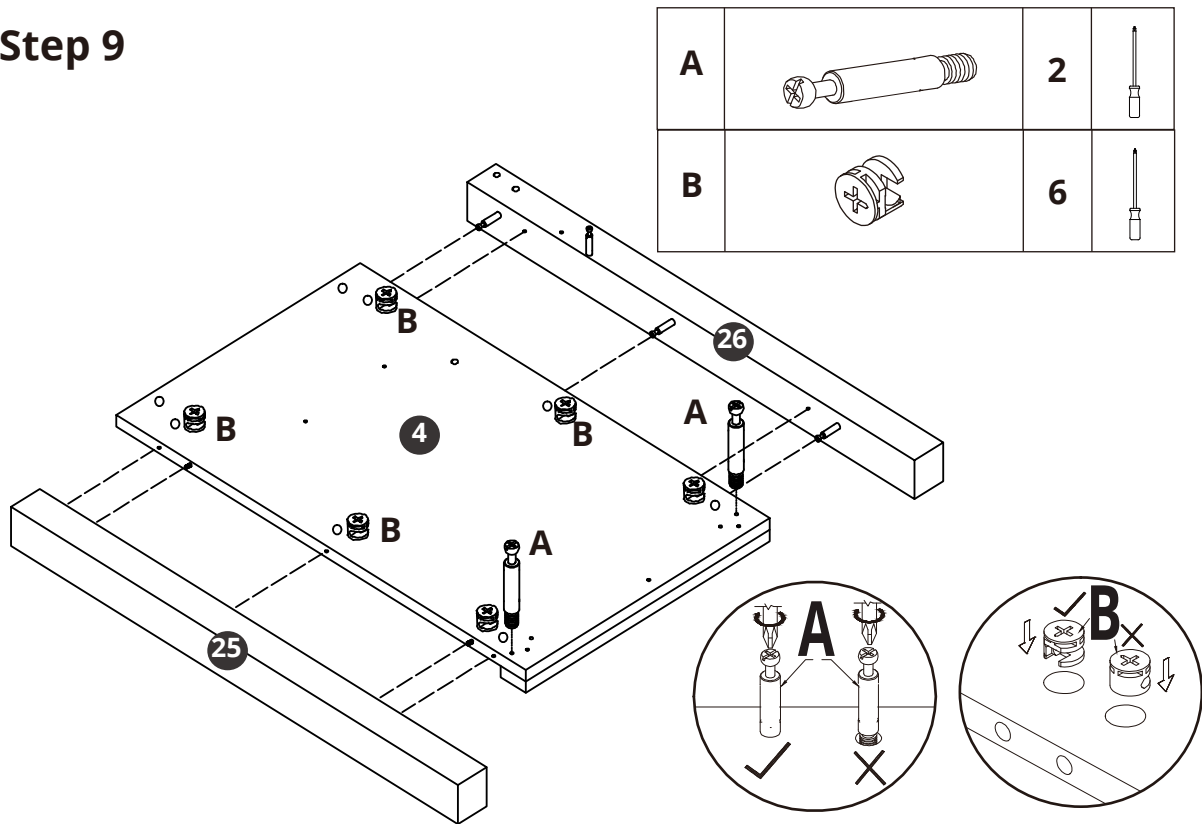

Step 10

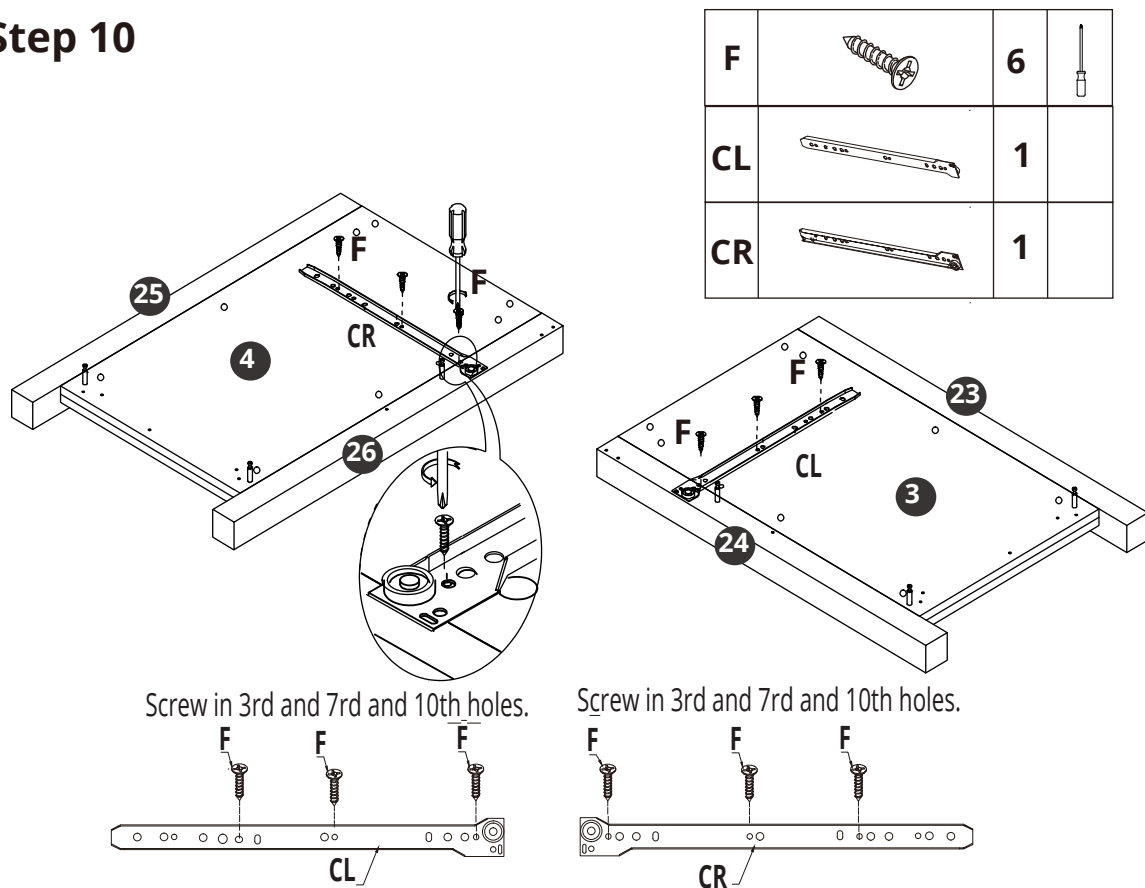

ASSEMBLY INSTRUCTIONS

Step 11

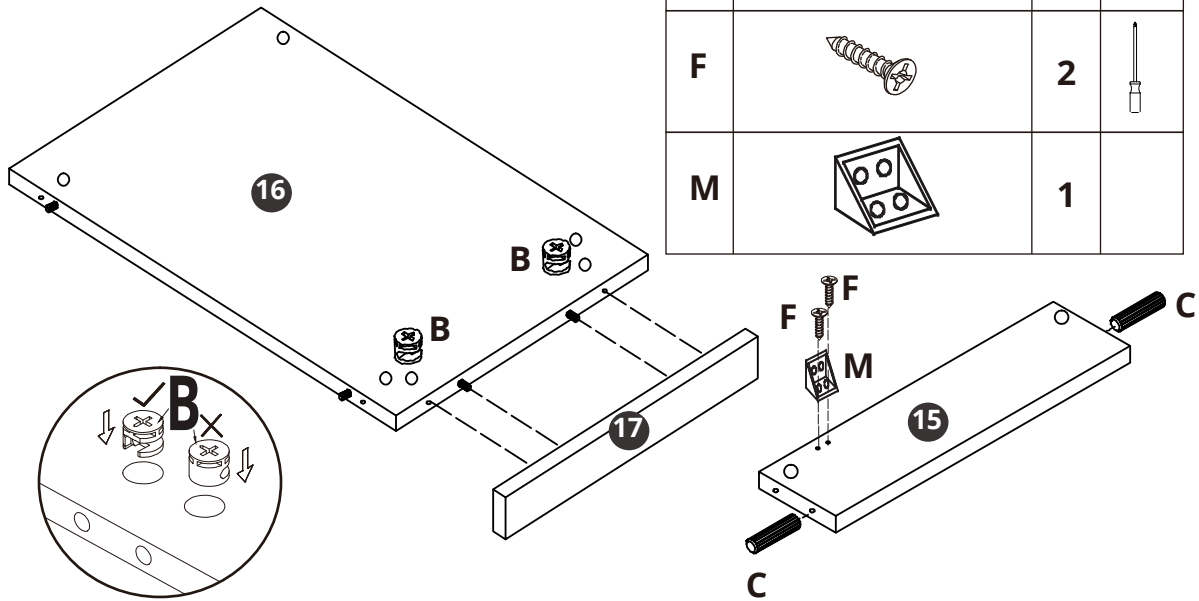

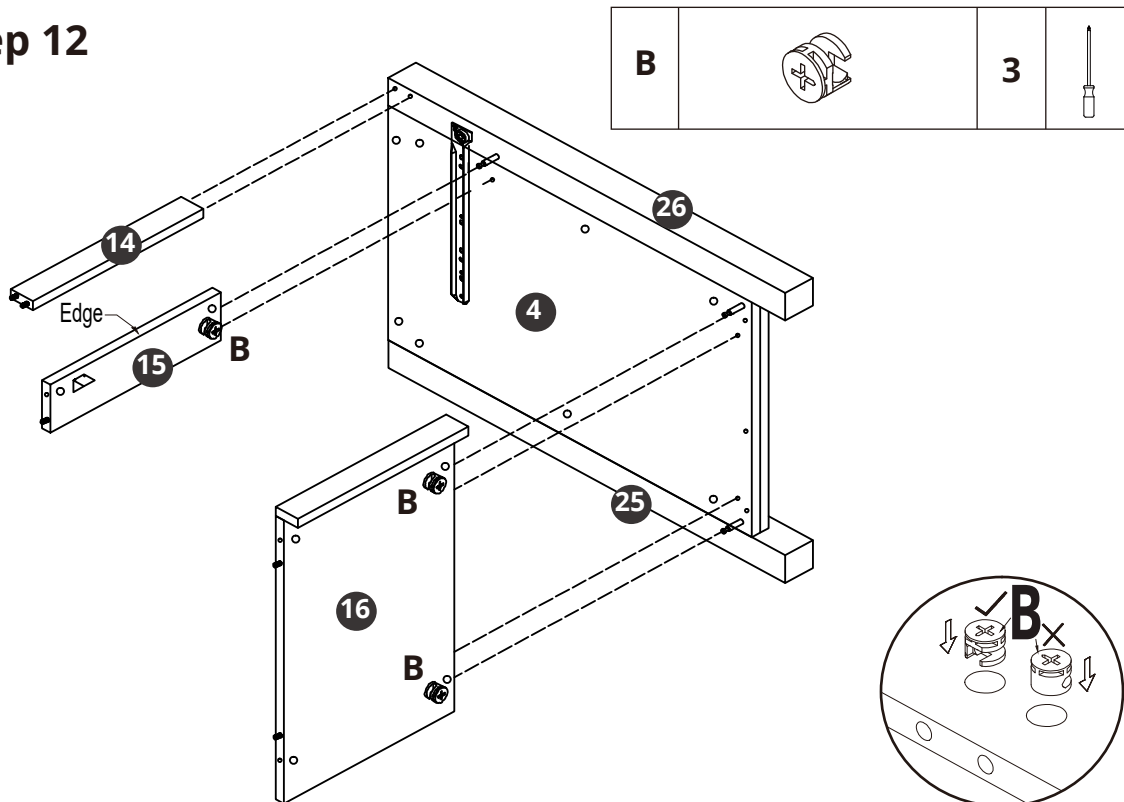

Step 12

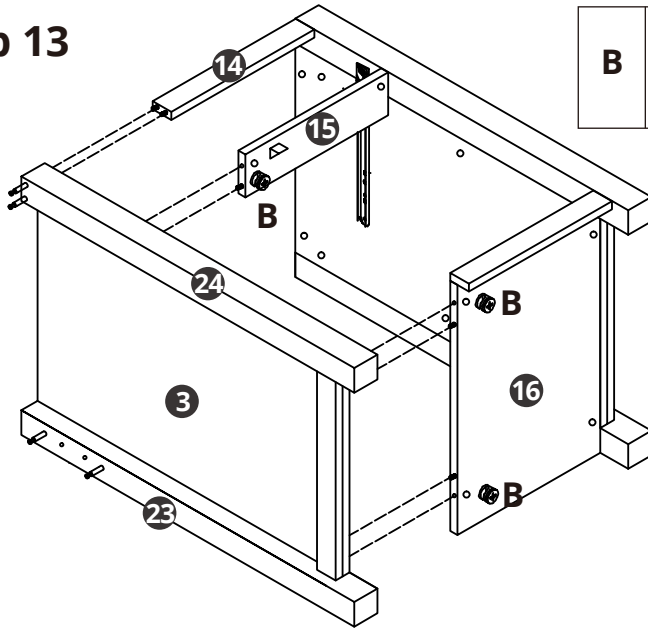

ASSEMBLY INSTRUCTIONS

Step 13





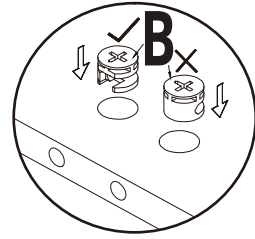

B		3	
---	---	---	---

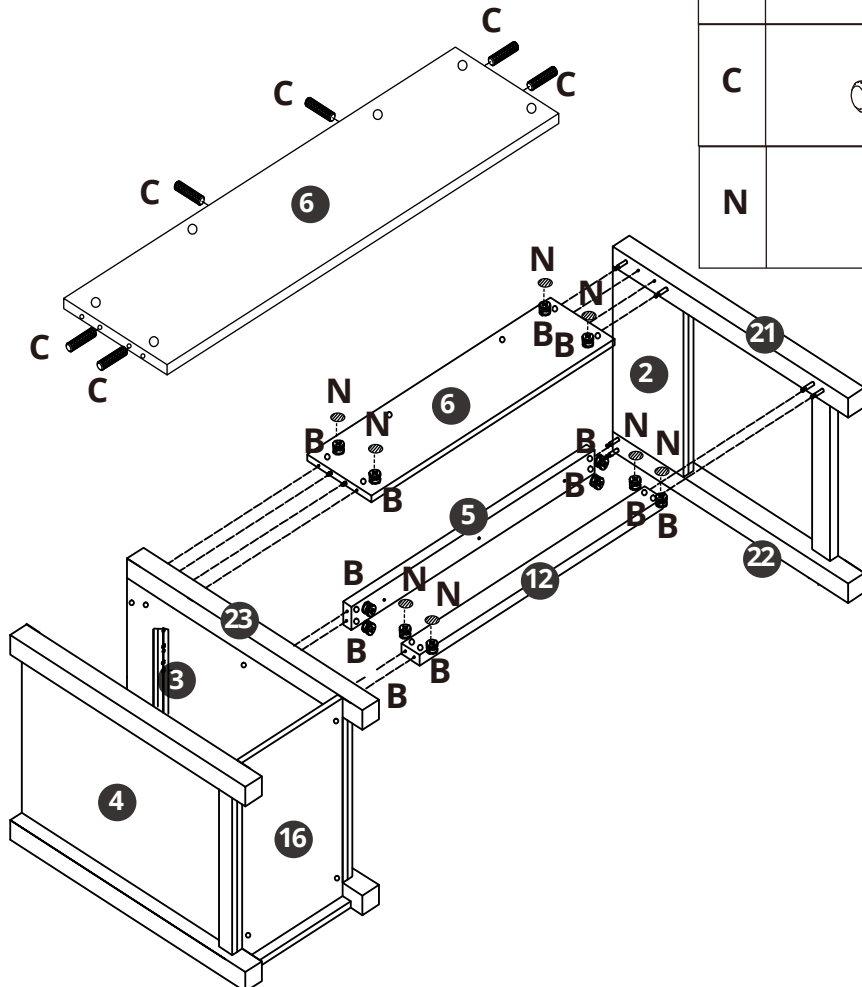

Step 14





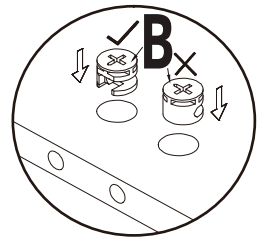
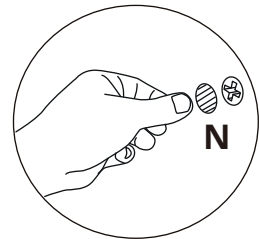



B		12	
C		6	
N		8	

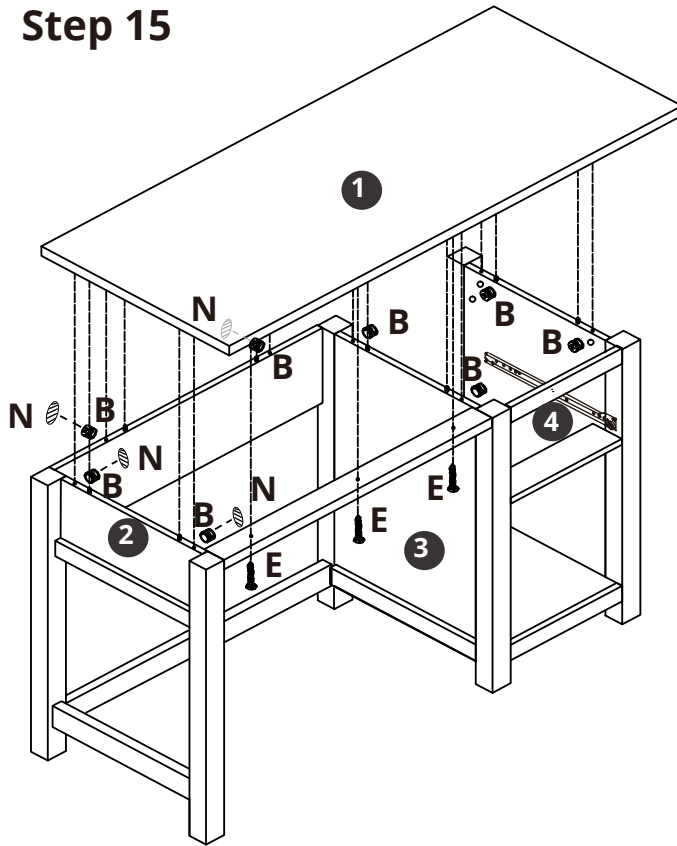

ASSEMBLY INSTRUCTIONS

Step 15





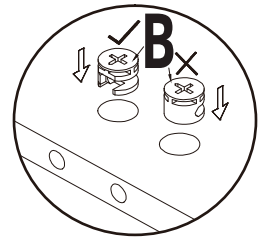
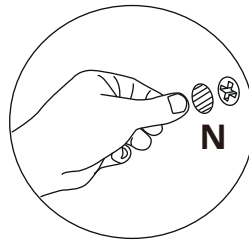

B		8	
E		3	
N		4	

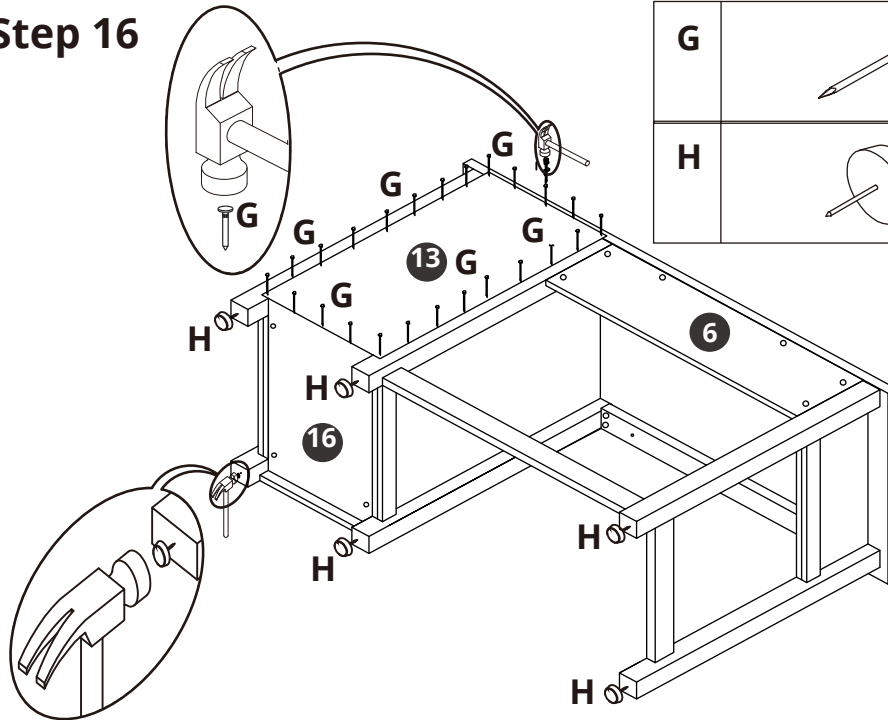

Step 16





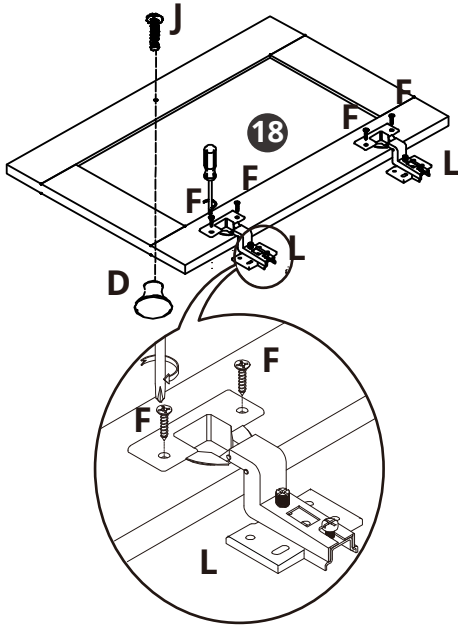

G		24	
H		6	

ASSEMBLY INSTRUCTIONS

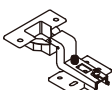

Step 17

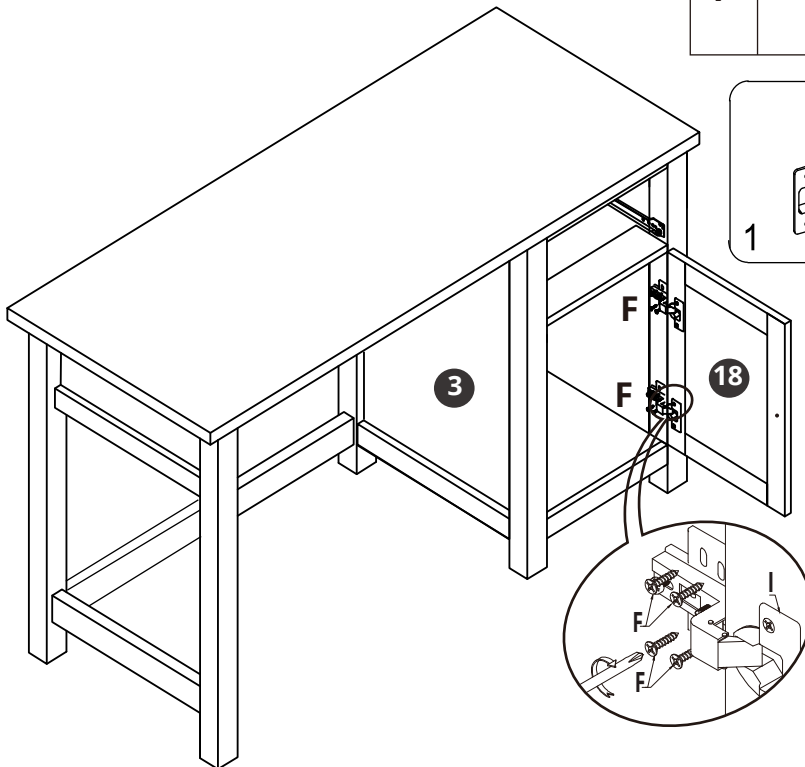

J		1	
D		1	
L		2	
F		4	

Step 18





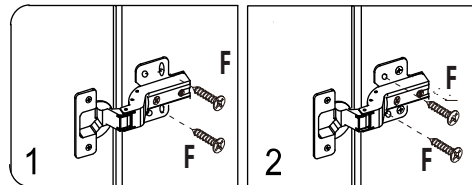

F		8	
---	---	---	---

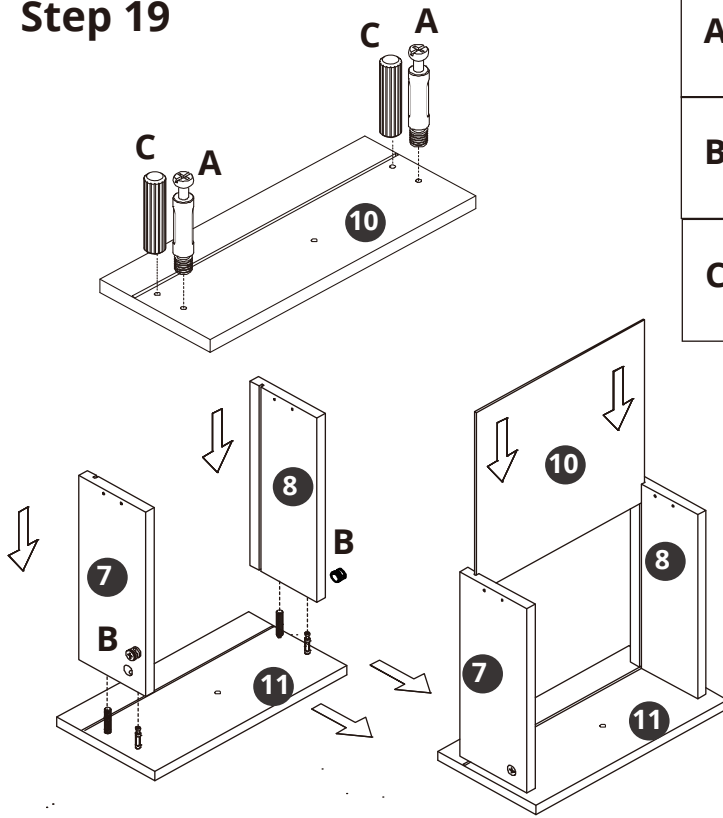

ASSEMBLY INSTRUCTIONS

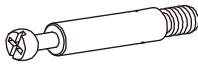
Step 19





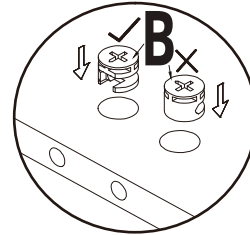
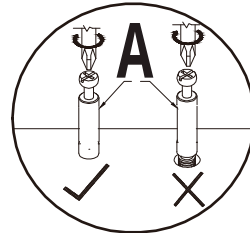

A		2	
B		2	
C		2	

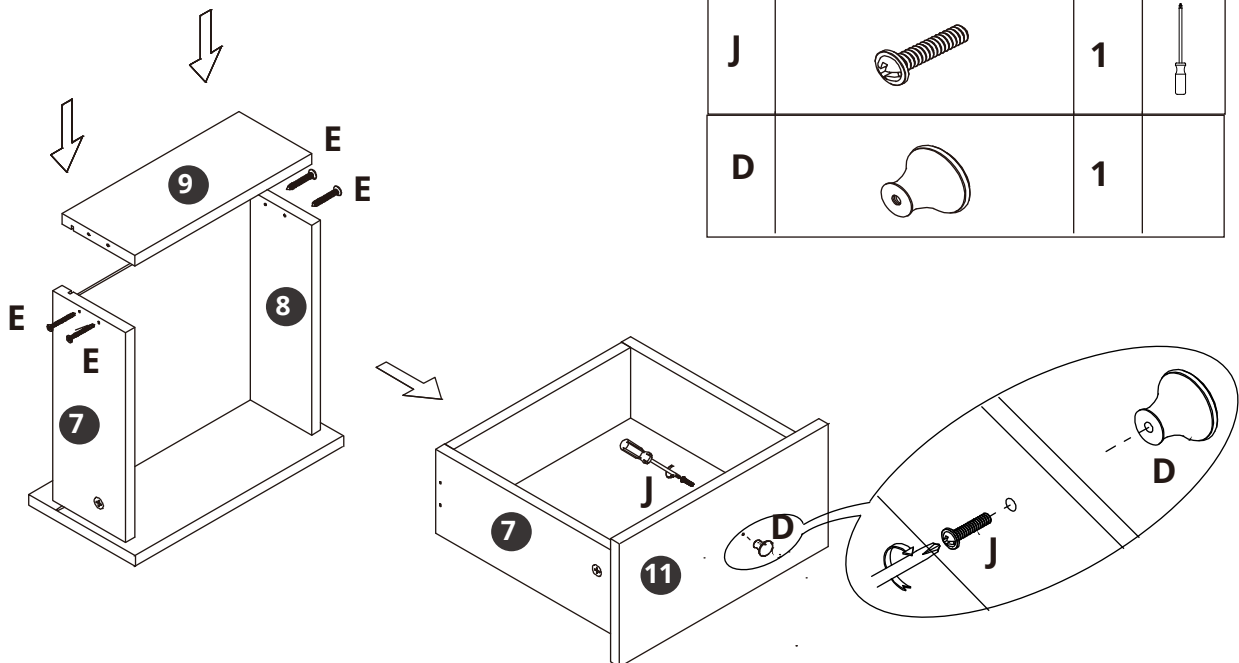



Step 20



E		4	
J		1	
D		1	

ASSEMBLY INSTRUCTIONS

Step 21

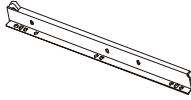
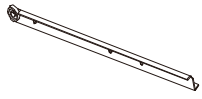
F		4	
DR		1	
DL		1	

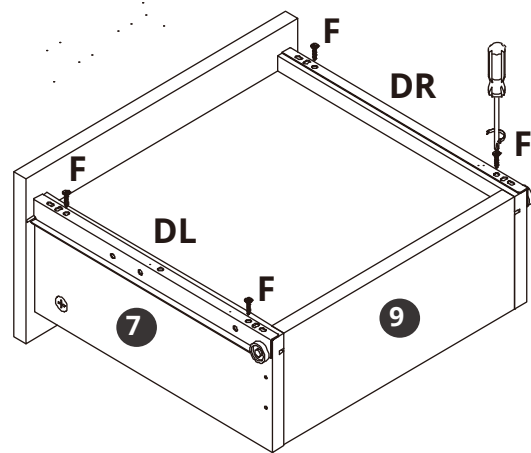
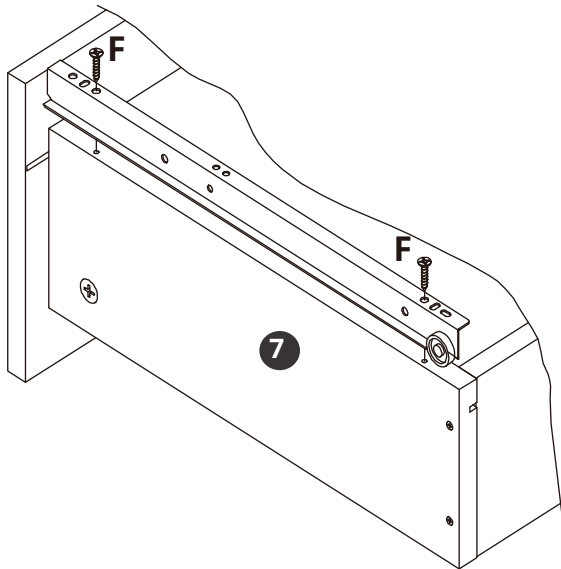

Step 22

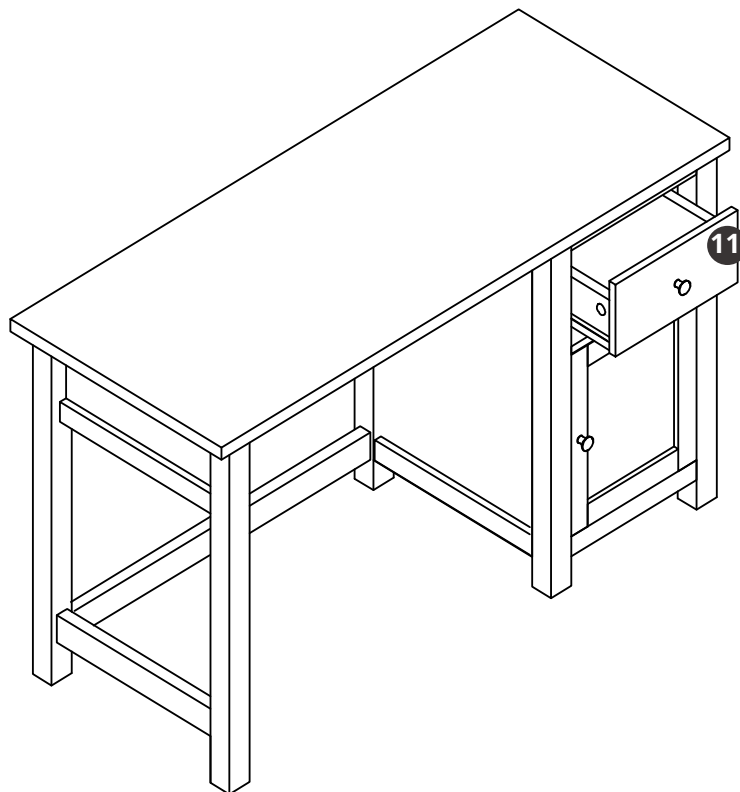

ASSEMBLY INSTRUCTIONS

Step 23

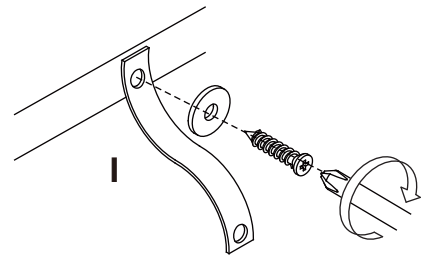
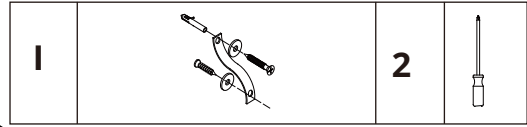
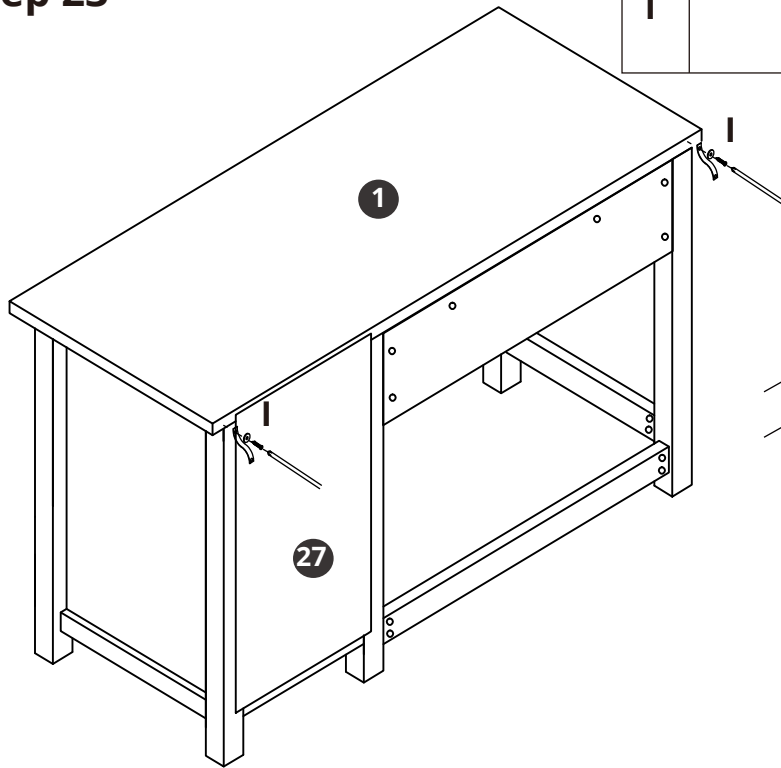

Step 24

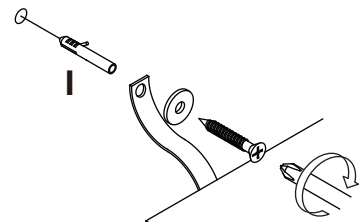
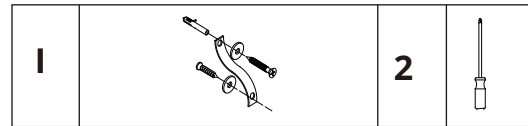
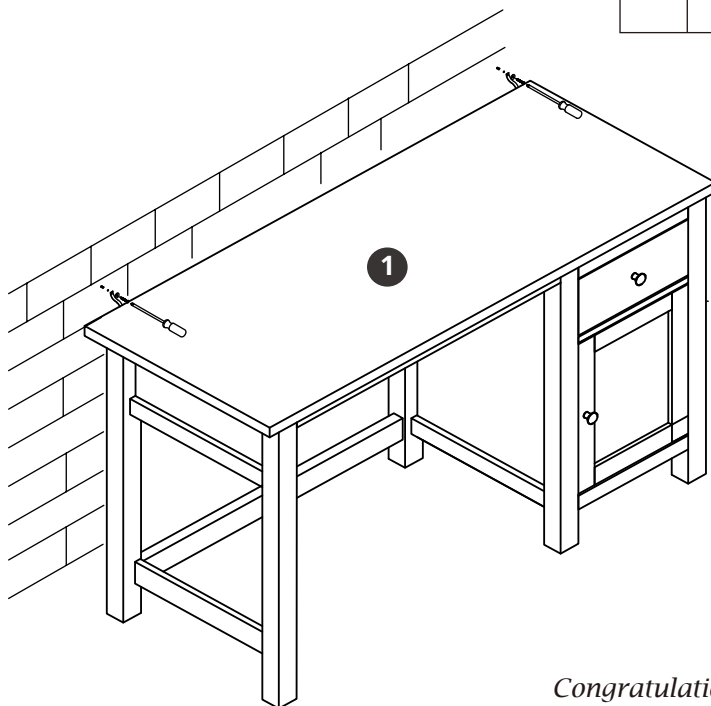

*Congratulations!
Now you have finished assembling the product.*

DOOR ALIGNMENT



Customer Attention:

To align doors and control gap in between doors. Product doors may need adjusting during and after assembly. This can be done by adjusting appropriate screws. See below illustration.

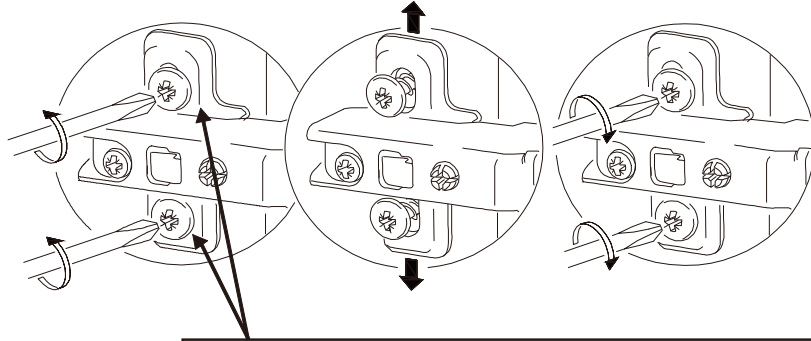
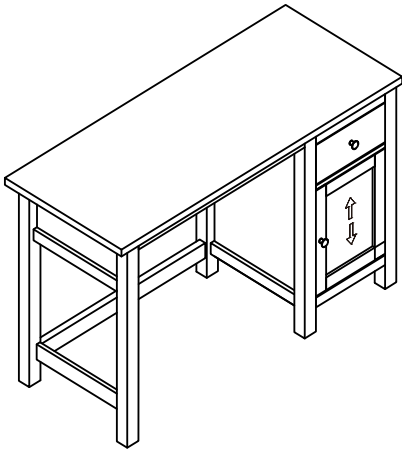

Vertical Door Adjustment:

Loosen both screws on all hinges and lift the door to the desired height. This allows an even space at the top and bottom between the door and frame.

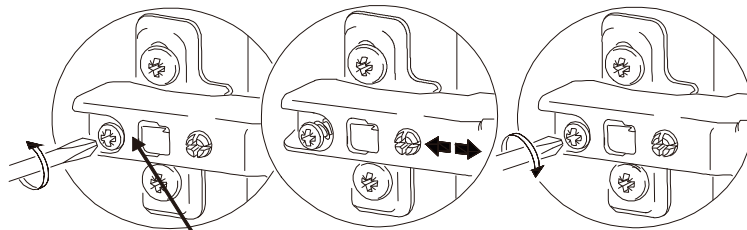
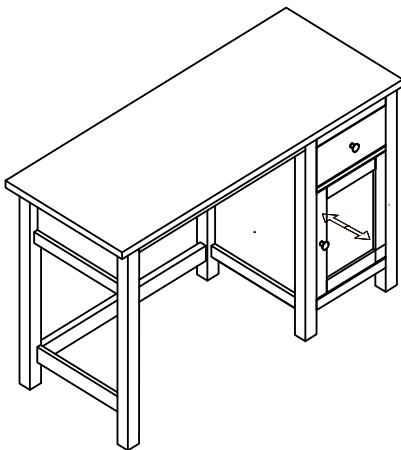

Lateral Door Adjustment:

If door is hinge bound, (rubbing on frame as you close or open door) loosening screw shown and move the door in appropriate direction. (In or out)

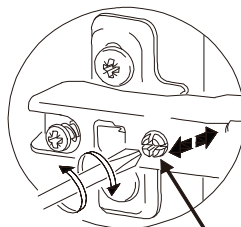
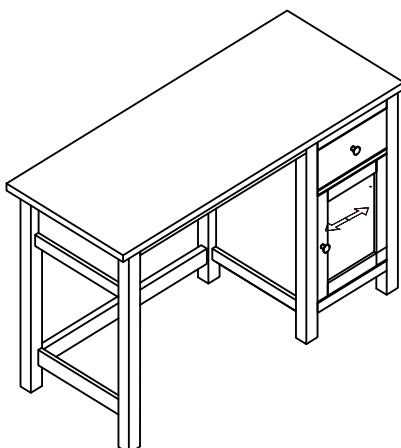

Horizontal Door Adjustment:

Rotate Screw clockwise or anticlockwise. This will produce an even gap between doors and frame.

A Guide to - Wall Mounting & Fixings

Important note:

If plastic wall plugs are supplied with your product:



- these are only suitable for use in masonry walls.

If you are in any doubt about the correct wall plugs for your wall, seek professional advice.

Failure of the product due to using incorrect fixings is the responsibility of the installer.



Important: When drilling into walls always check that there are no hidden wires or pipes etc.

Make sure that the screws and wall plugs being used are suitable for supporting your unit. Consult a qualified person if you are unsure.

Hints:

- 1: **General rule:** ⚠ Always use a larger screw and wall plug if you are not sure.
- 2: Ensure you use the recommended drill bit to match the wall plug and hole size.
- 3: Ensure you drill the hole horizontally, do not force the drill or enlarge the hole.
- 4: Take extra care when drilling high walls, ceilings and ceramic tiles. Ensure wall plugs are inserted beyond the thickness of the ceramic tiles to avoid the tiles splitting or cracking.
- 5: Ensure wall plugs are well fitted and are a tight fit in the drilled hole.

Types of walls

You can use one of the following types of wall plug if your walls are made of brick, breeze block, concrete, stone or wood.

No.1 "General Purpose" wall plug

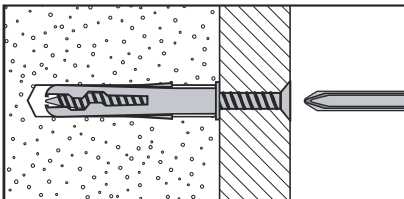

Generally aerated blocks should not be used to support heavy loads, use a specialist fitting in this case. For light loads, general purpose wall plugs can be used.

No.2 "Plasterboard" wall plug

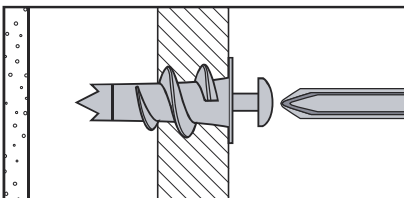

For use when attaching light loads on to plasterboard partitions.

No.3 "Cavity Fixing" wall plug

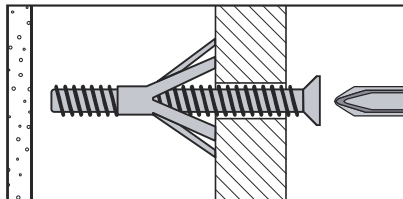

For use with plasterboard partitions or hollow wooden doors.

No.4 "Cavity Fixing-Heavy Duty" wall plug

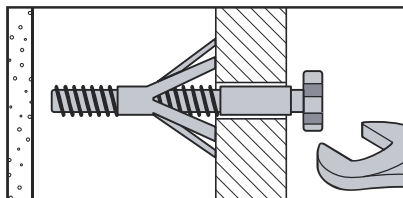

For use when fitting or supporting heavy loads such as shelving, wall cabinets and coat racks.

No.5 "Hammer Fixing" wall plug

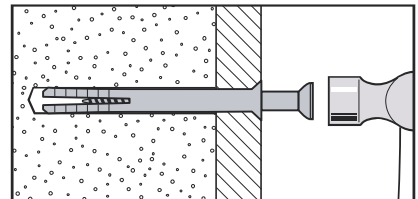

For use with walls stuck with plasterboard. The hammer fixing allows it to be fixed to the wall rather than the plasterboard. Always check the fixing is secure to the retaining wall.

No.6 "Shield Anchor" wall plug Heavy loads

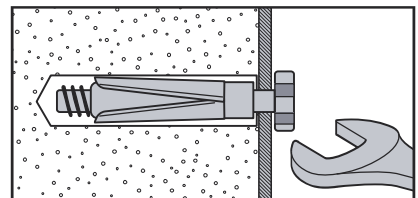

For use with heavier loads such as TV & HiFi speakers and satellite dishes etc.



Care & Maintenance

Safety: Always check the fitting and location to ensure your safety in and around the home.

Fitting: From time to time check the fitting to ensure the wall plugs or screws do not become loose.