

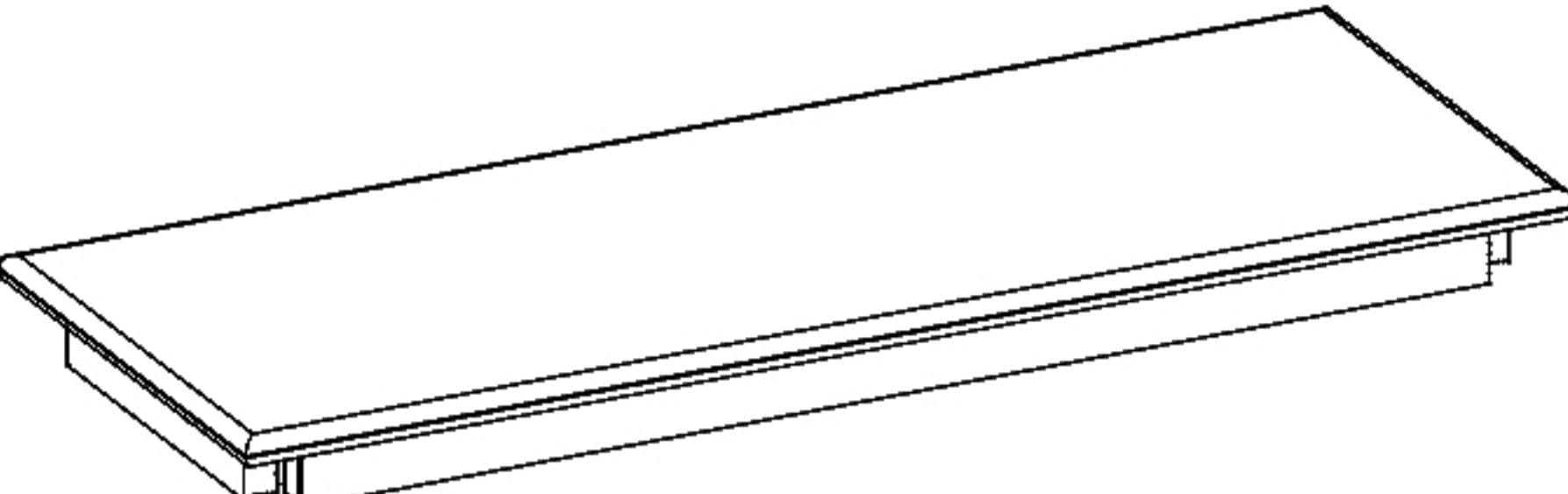

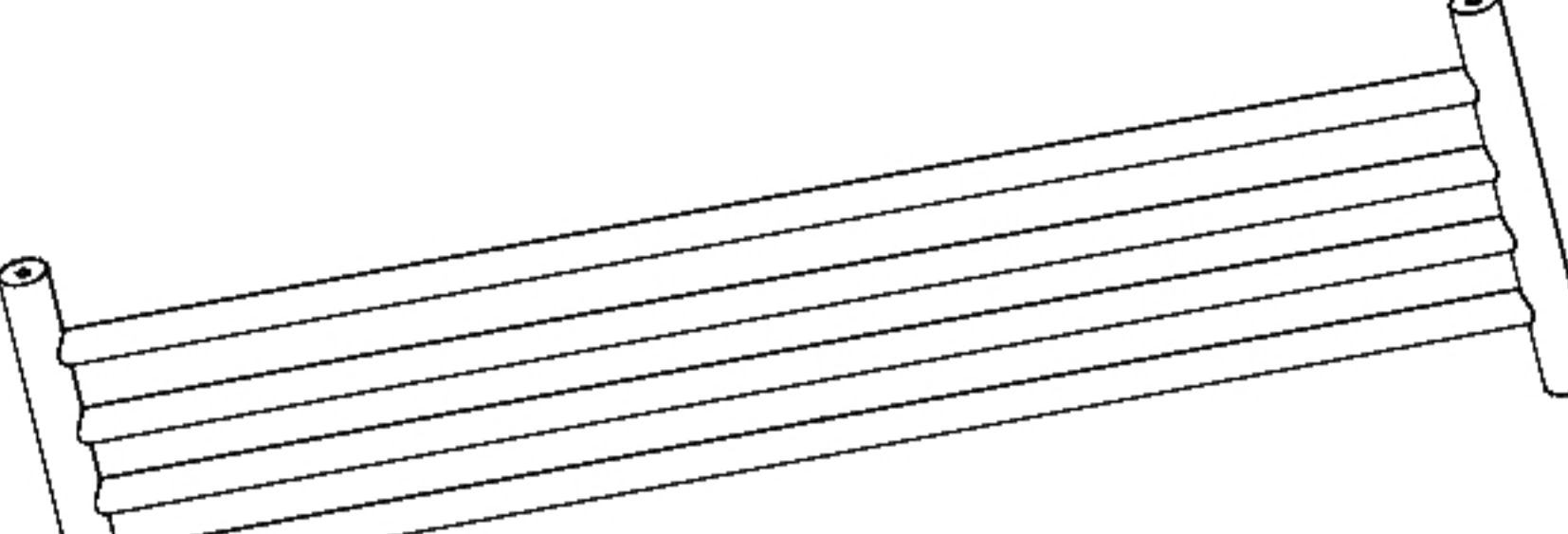





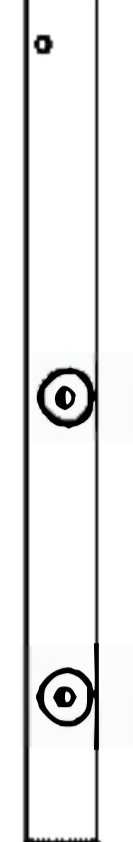
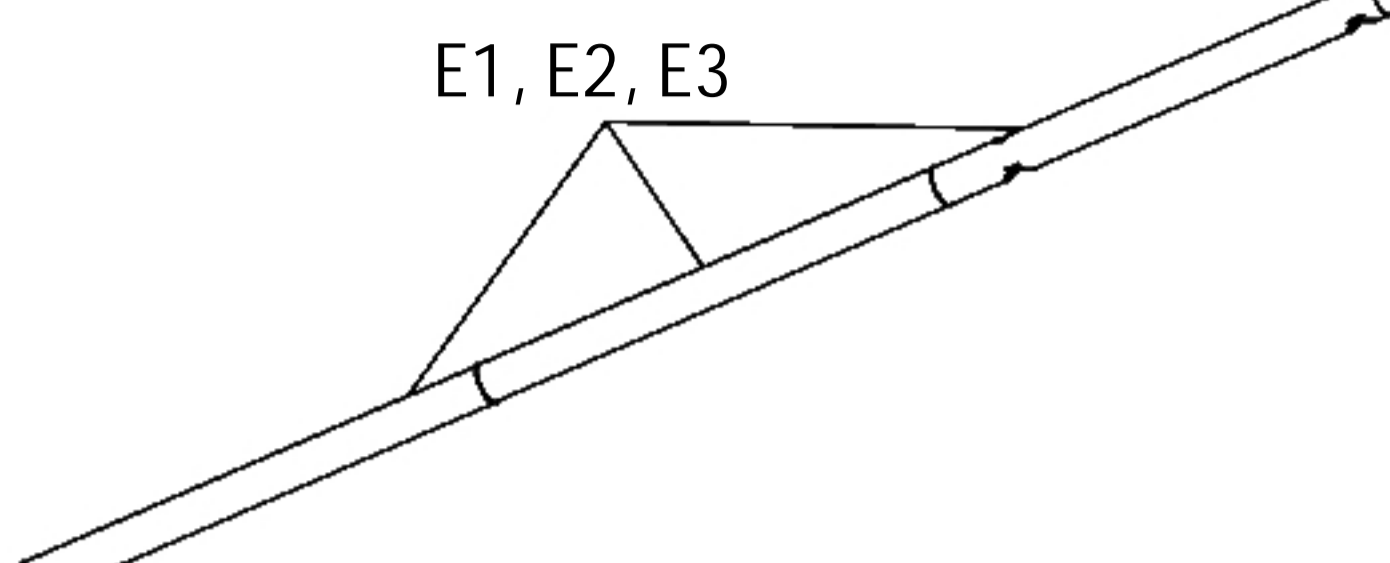
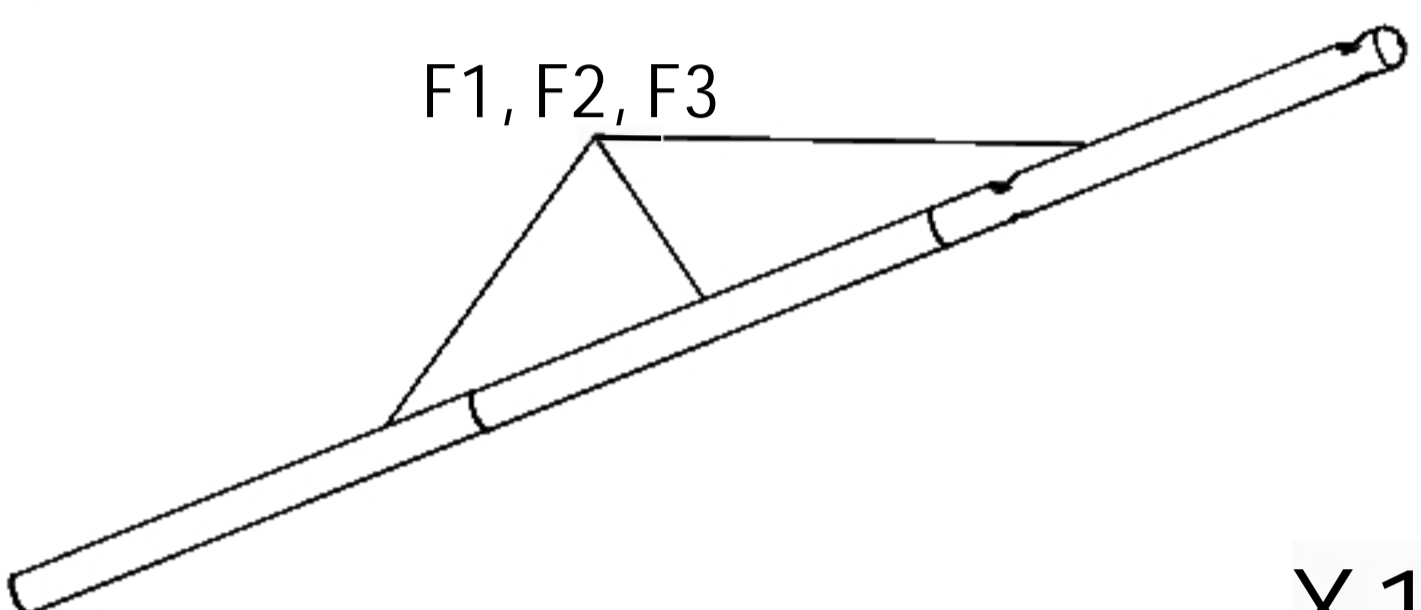
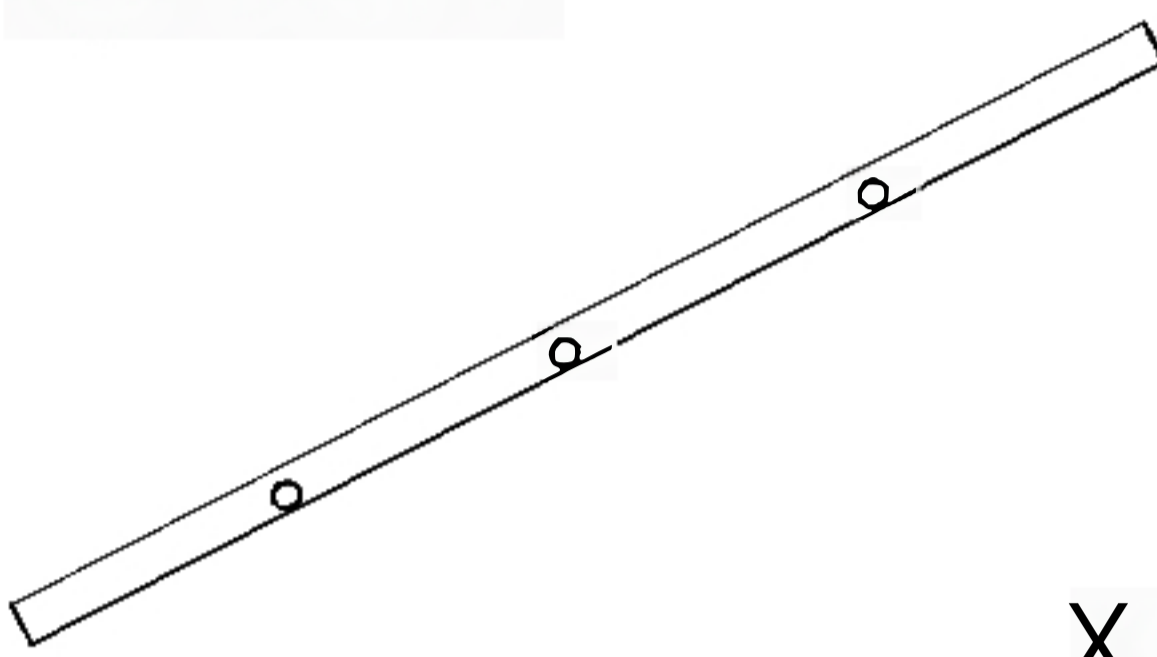
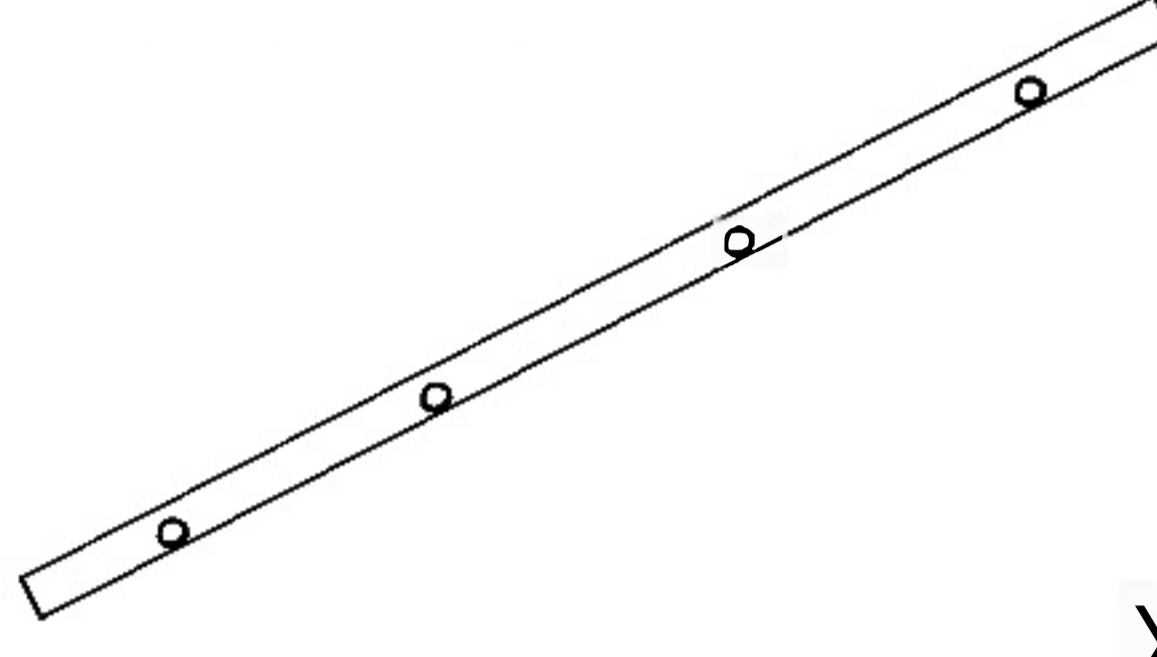

Assembly instructions

Part name							
A Bench frame  X1		B Shelf  X1		C Foot1  X2	D Foot2  X2	E Column1  X1	
F Column2  X1		G1 Crossbar1  X1	G2 Crossbar2  X1	H Long hook  X4		J Short hook  X7	
① Flat-head overhanging wire 7*50  X9	② Hexagon socketscrew 1/4*50  X4	③ Spring spacer 1/4*8  X4	④ Flat gasket 1/4*13  X4	⑤ Hexagon socket screw 5/16*35  X2	⑥ Flat spacer 5/16*19  X2	⑦ 4#Wrench + 5#Wrench  X1+1	⑧ Foot pad  X8

Assembly Steps

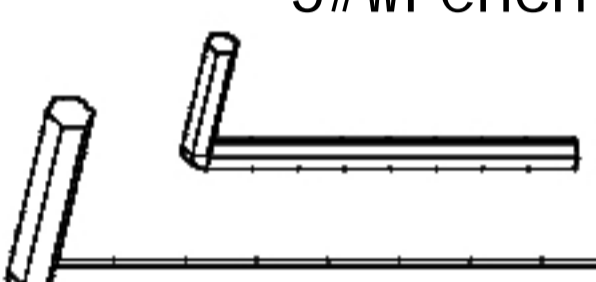
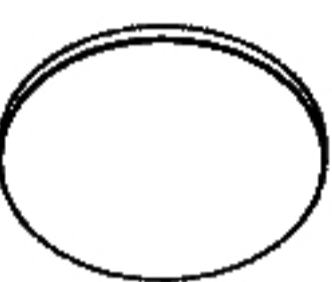
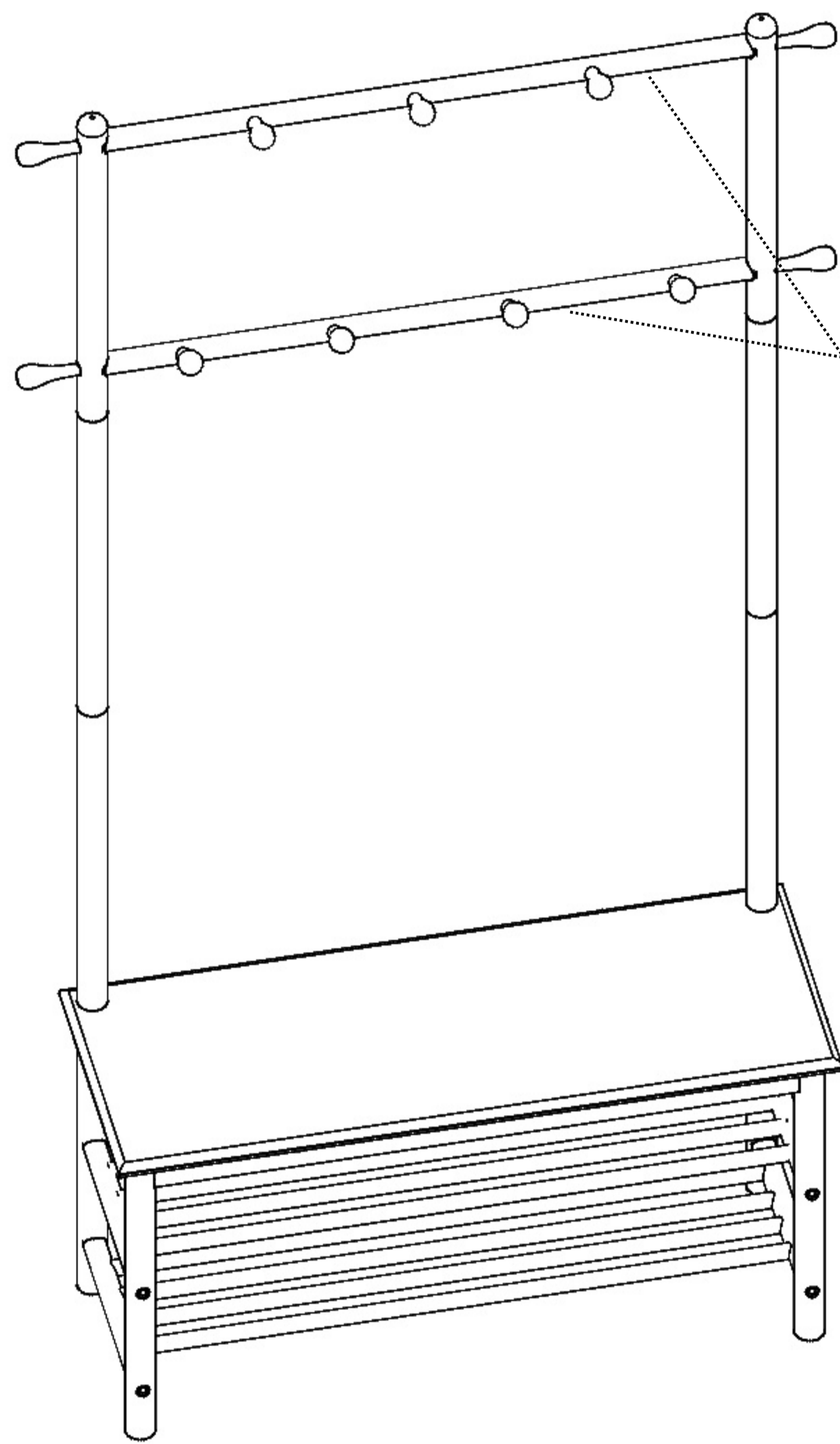

Freely choose the installation positions of #G1 and #G2 on the upper and lower levels.

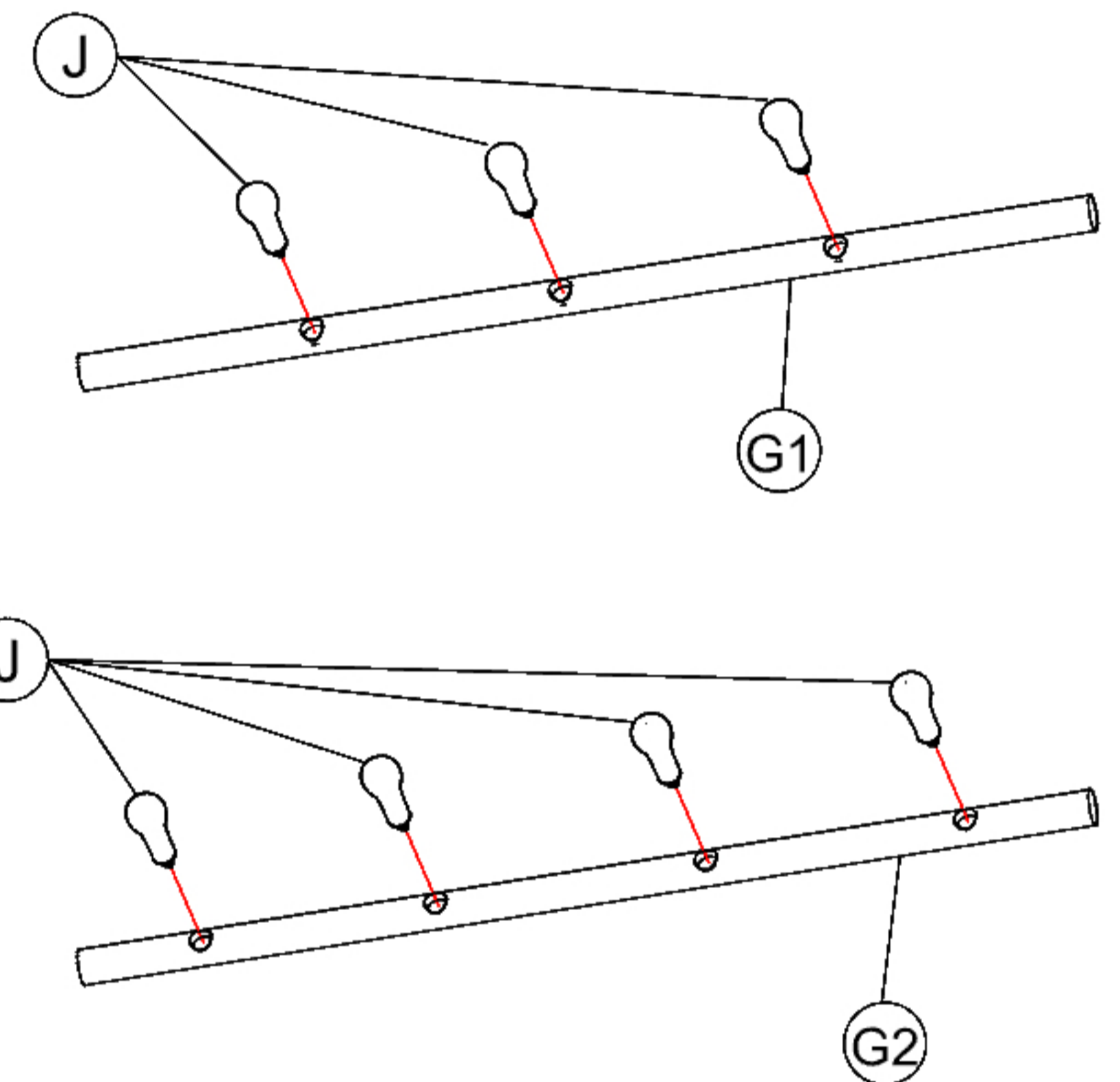

Step2:
Tighten the J# Short hooks in the corresponding holes of the G1#G2# crossbar as shown in the diagram.

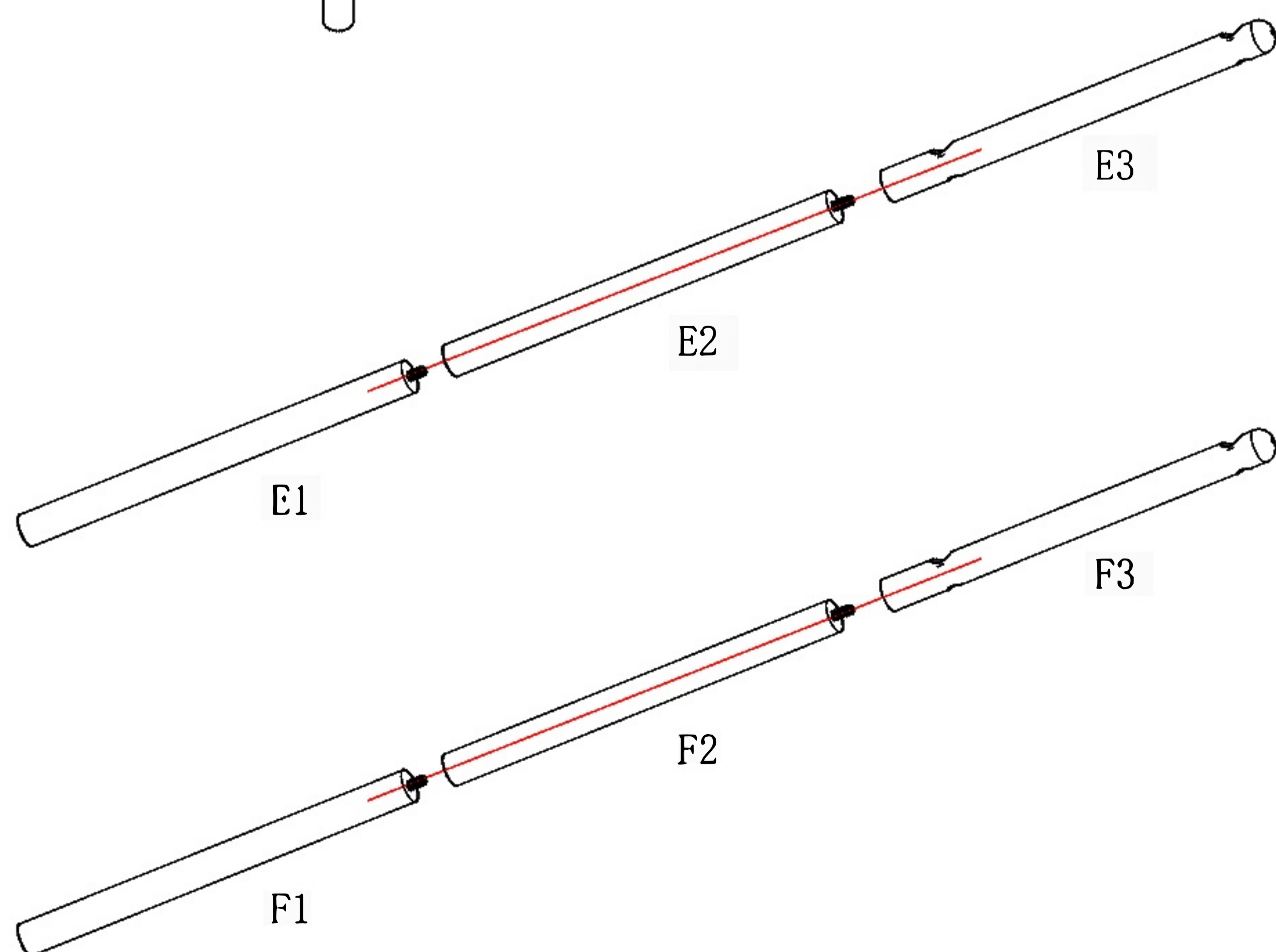

Step 1:
Connect columns E# and F# head to tail in sequence as shown in the figure, where 3# is the top pole, 2# is the center pole, and 1# is the bottom pole.

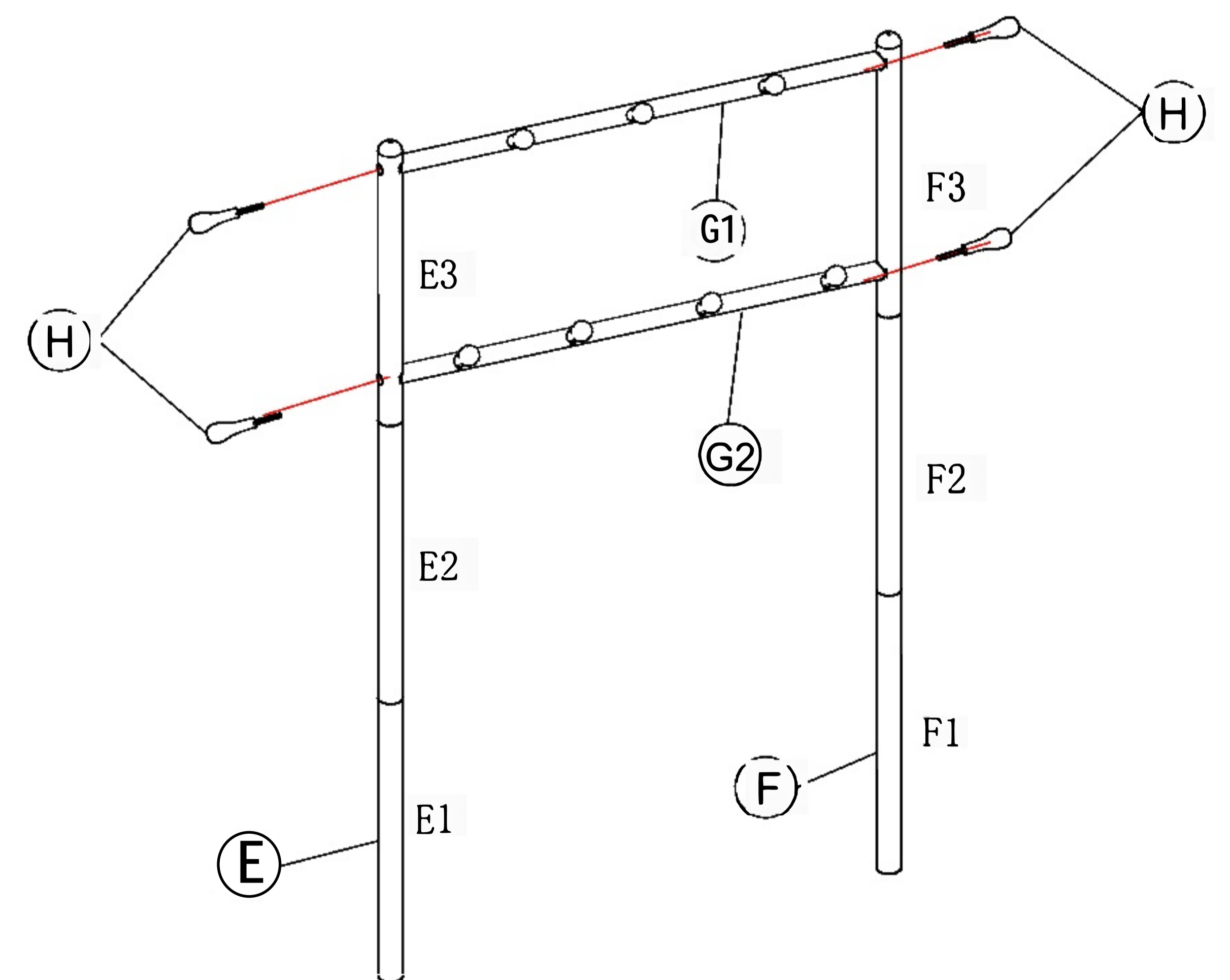

Step3:
Tighten the H# Long hooks on the E# and F# columns to connect with the G1#G2# crossbar respectively as shown in the figure.
(Note: E3# small hole facing outward.)

Assembly Steps

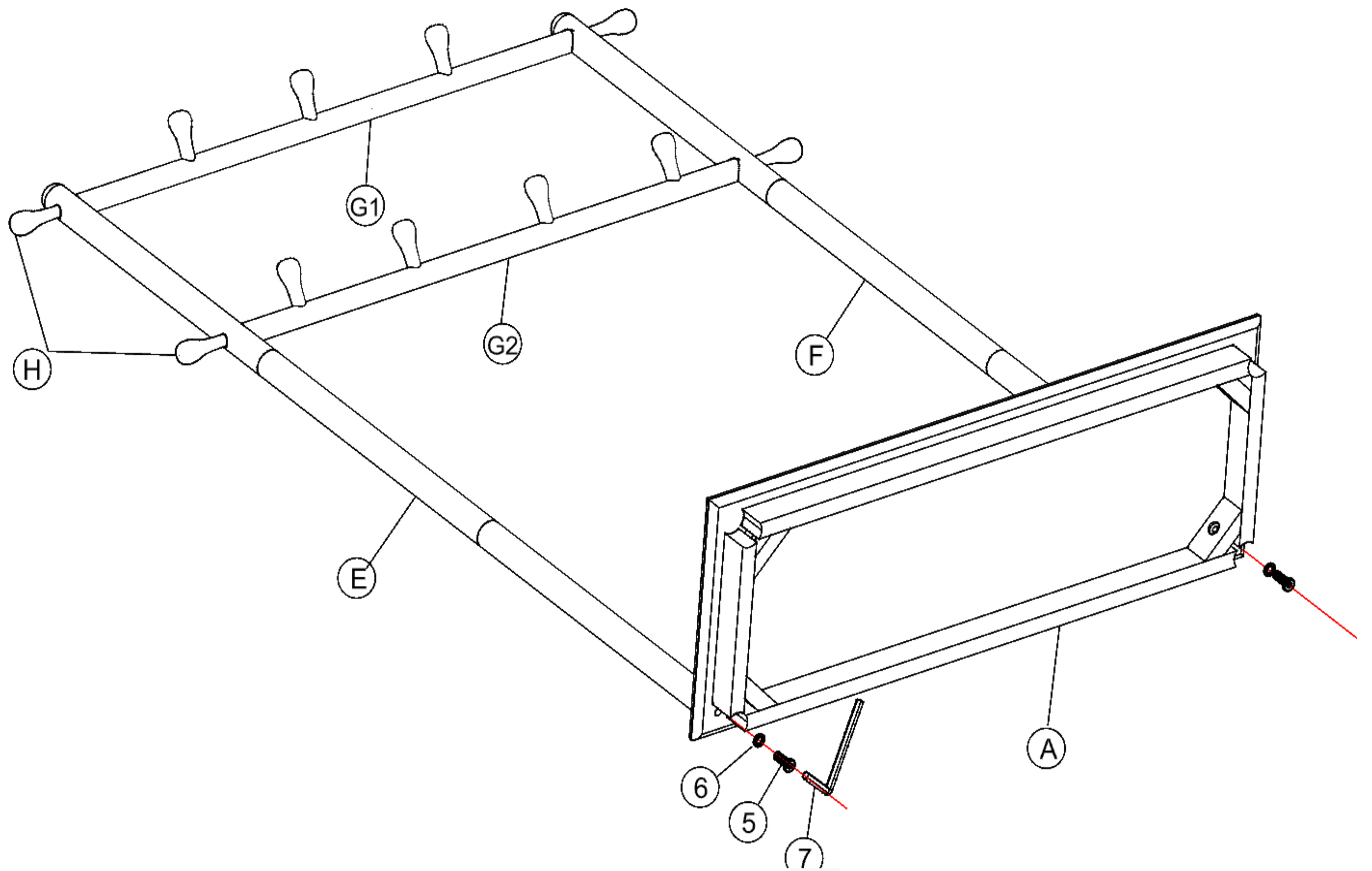
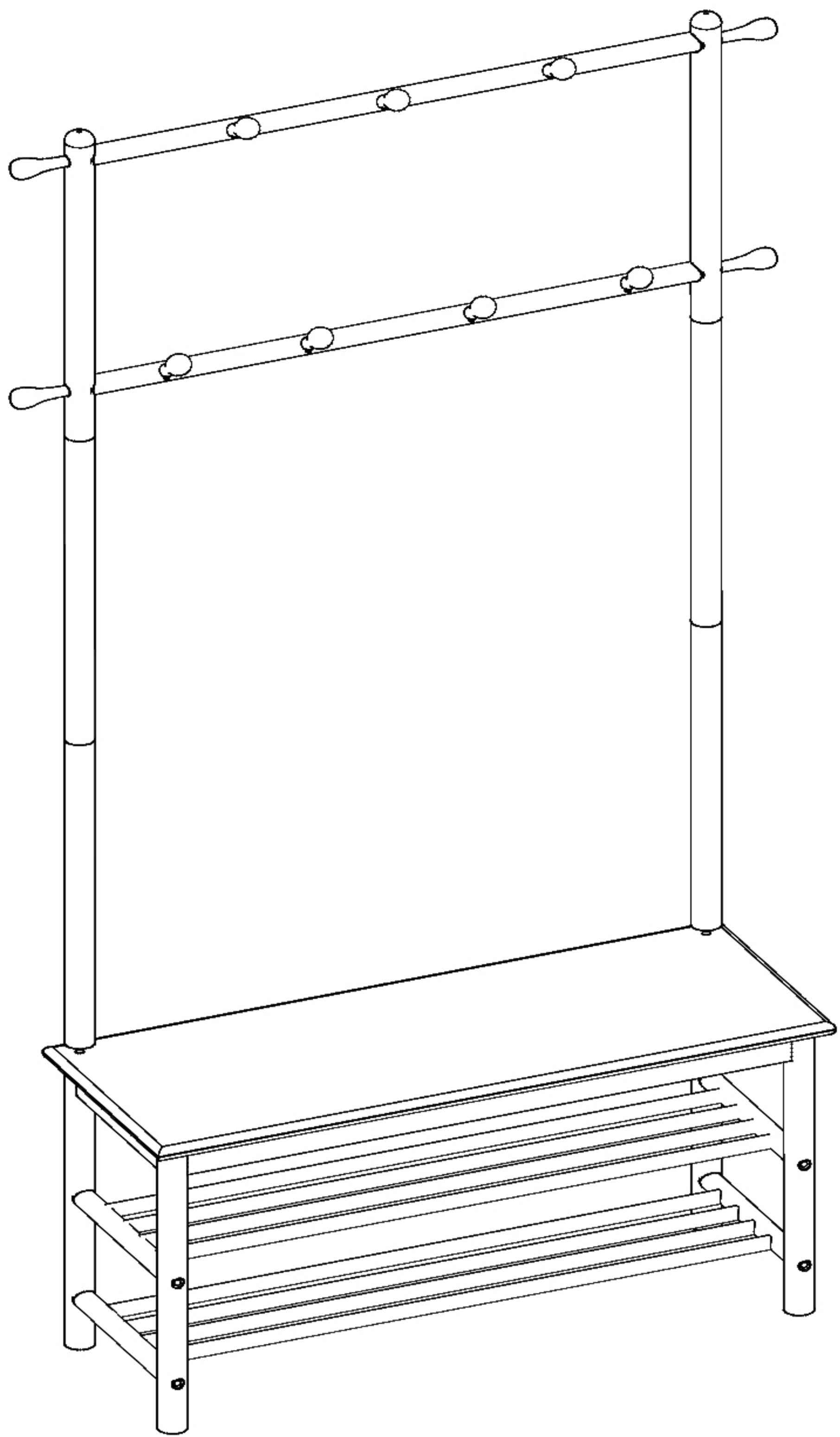

Step4:

Lay the bracket flat as shown and secure the **A#** Bench frame to the **E#/F#** top beam with **⑤#** Hexagon screws and **⑥#** Flat spacers.

Step5:

Secure the **C#** and **D#** feet to the **E#** layer frame with **①#** Flat-head overhanging wire as shown in the diagram.

(Note: screws are not lemon tight first to complete the steps and then tighten).

Before installation, note that the feet have through-hole direction for the following.

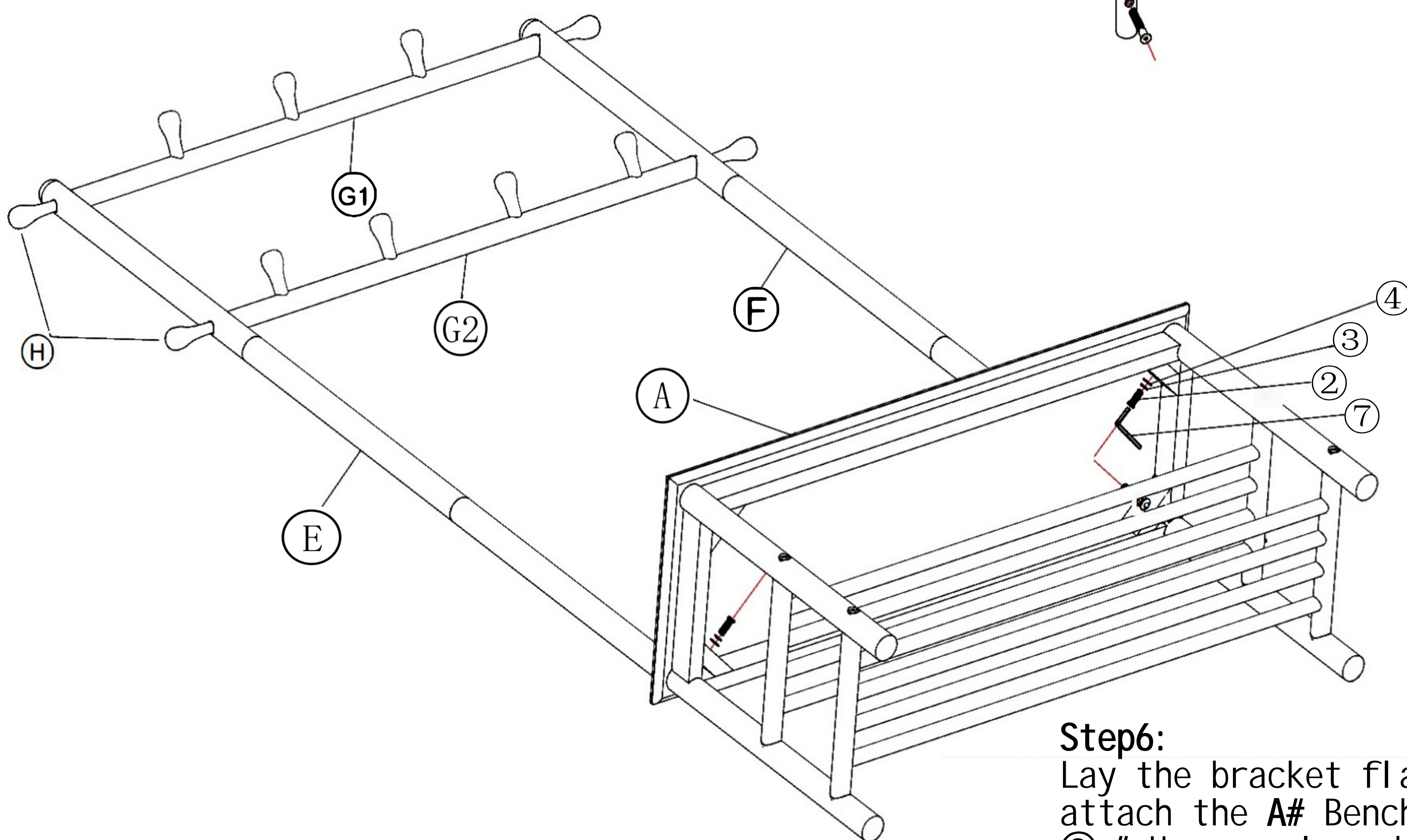
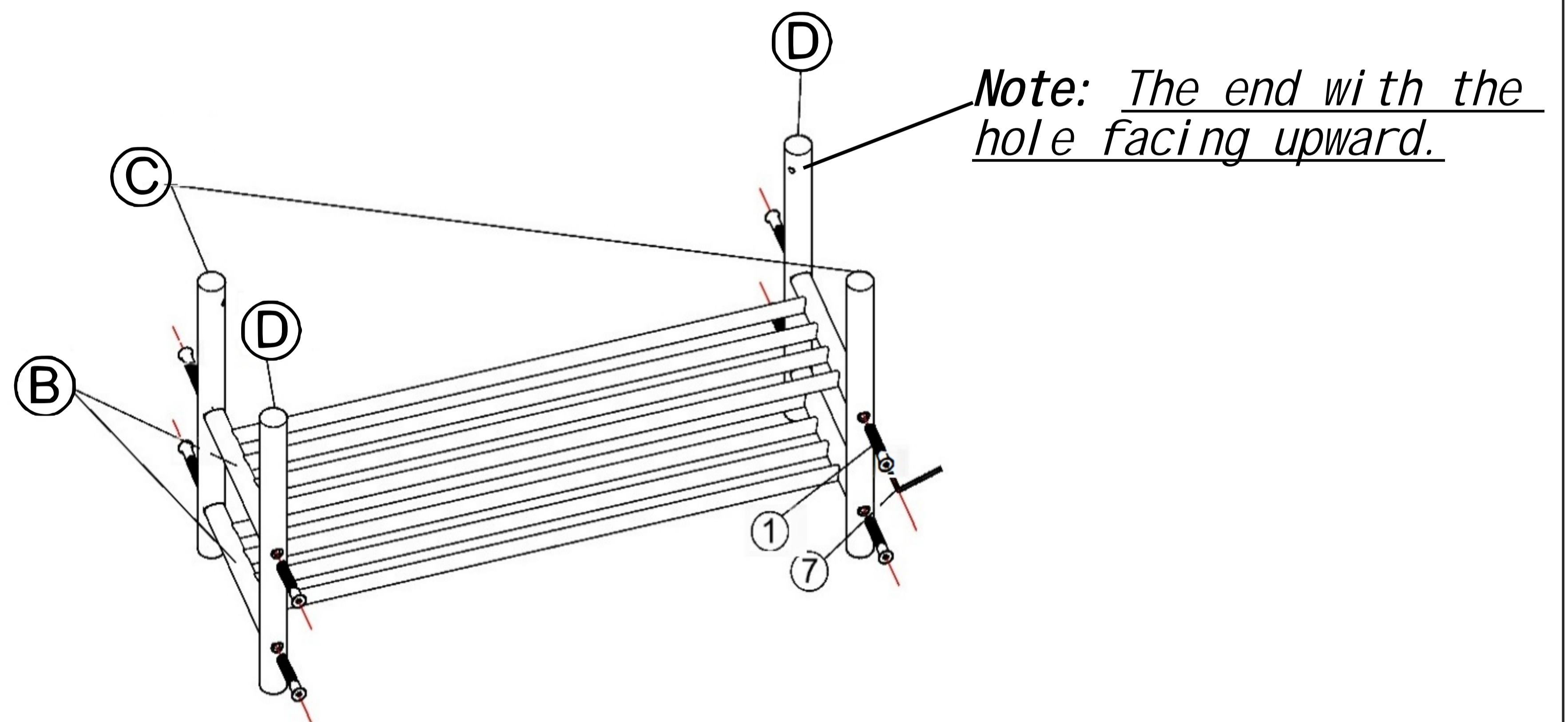

Step6:

Lay the bracket flat as shown in the diagram and attach the **A#** Bench frame to the **C#/D#** feet using **②#** Hexagonal socket screws and **③#** Spring spacers **④#** Flat gaskets. Finally attach **⑦#** felt foot pads to the 4 legs to complete the assembly.

(Note: Thread in the **③#** spring shims first and then the **④#** Flat gaskets.)