

Table

Assembly Instructions

Assembly Tips:

To properly align metal parts, all hardware should first be fastened to about one rotation from being snug. **DO NOT** "tighten as you go."

Note: While the product can be assembled by one person, a second set of hands will help considerably.



Step 1

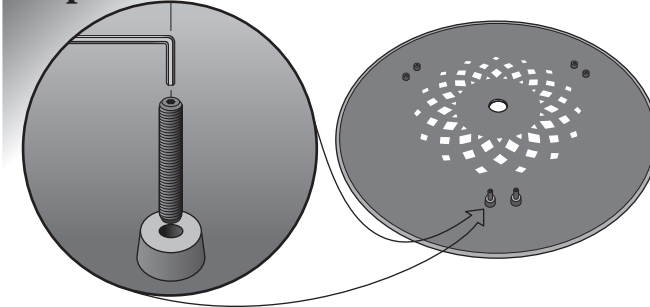

Lay the table top upside down on a soft surface, taking care not to scratch the top. Insert the threaded metal posts (6) into the threaded holes on the underside of the table top with the hex hole facing up. **Do not tighten, as this could force the post through the table top.**

Step 2

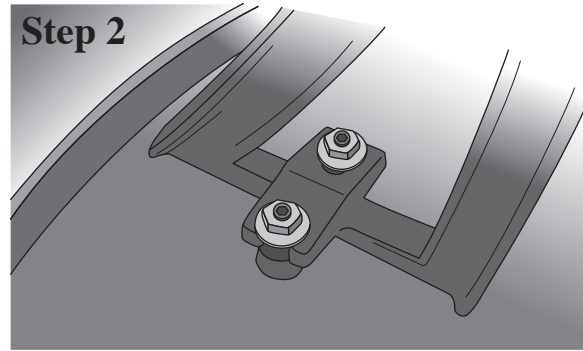

Slide the table legs over the metal posts and then attach the washer/nut combination to the posts. Hand tighten only.

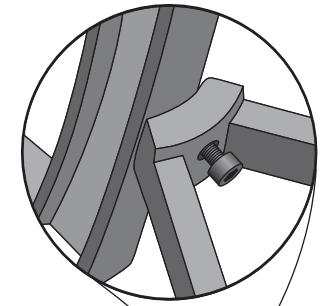

Step 3

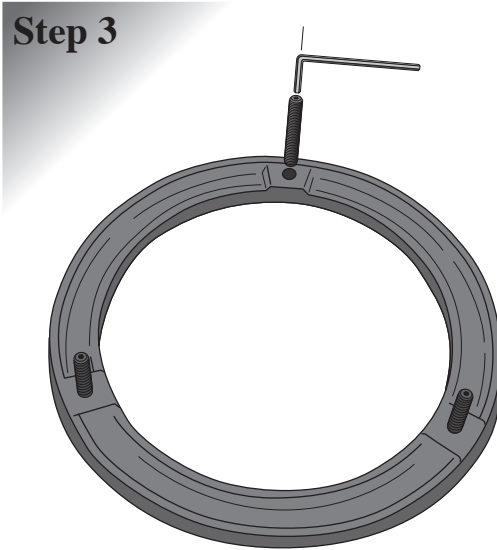

Insert the threaded metal posts (3) into the holes of the circle brace as shown. Snug them up with the supplied hex wrench, then back them off 2 turns

Step 4

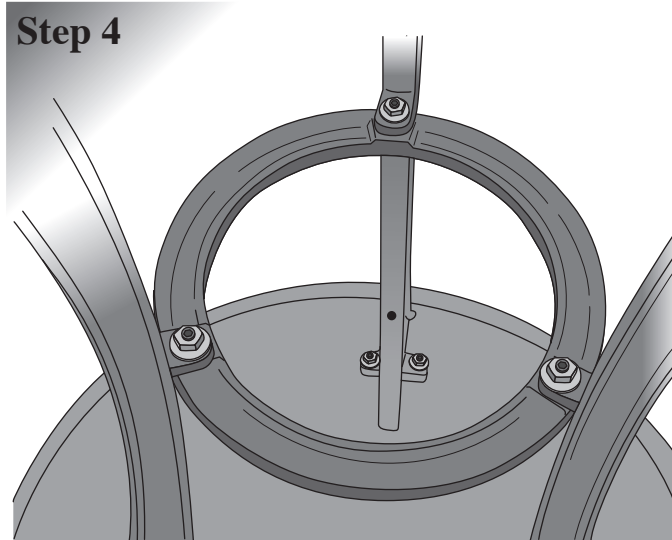

With the table and legs still upside down, attach the circle brace to the tabs on the legs as shown. Snug tight with a 9/16" wrench.

Step 5

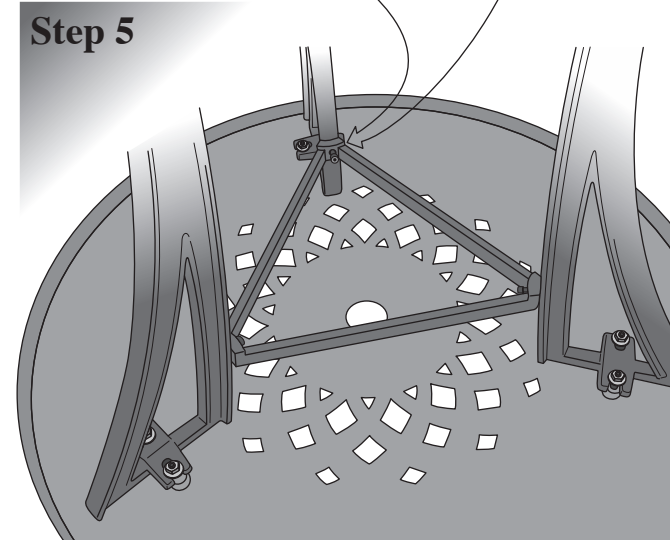

With the table and legs still upside down, attach the circle brace to the tabs on the legs as shown. When all nuts and washers have been hand tightened, begin to snug all nuts with a 9/16" wrench. Alternate until all are tight.

Parts List

Table

A. Table top	1
B. Table legs	3
C. Circle brace	1
D. Triangle brace	1

Hardware

1" Threaded posts	9
Nuts	9
Washers	9
Hex head screws	3