



ASSEMBLY INSTRUCTIO

DINING TABLE

Thank you for purchasing this quality product. Be sure to check all packing material care fully for small parts, which may have come loose inside the carton during shipment. Identify and count all parts and compare with the HARDWARE LIST below.

HARDWARE / PARTS LOCATION

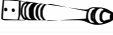
D1623 DT > Step 1 & 2 hardware > Inside red pack with red tape > Placed at corner near corner block > Table top > Place at the bottom > Leg > Inside labeled inner carton > Placed underneath table top > Leaf > Placed on top of leg box > Leaf support rail > Placed at side near corner block.

NO.	DESCRIPTION	SKETCH	QTY
A	Table Top		1Pc
B	Leg		4Pcs
C	Leaf		1Pc
D	Leaf Support Rail		2Pcs

NO.	HARDWARE LIST	QTY
1	 Bolt (Ø5/16"x75mm)	8Pcs
2	 Bolt (Ø5/16"x40mm)	4Pcs
3	 Spring Washer (Ø5/16x11x2mm)	12Pcs
4	 Flat Washer (Ø5/16"x19x2mm)	12Pcs
5	 Allen Wrench 4mm	1Pc

STEP 1

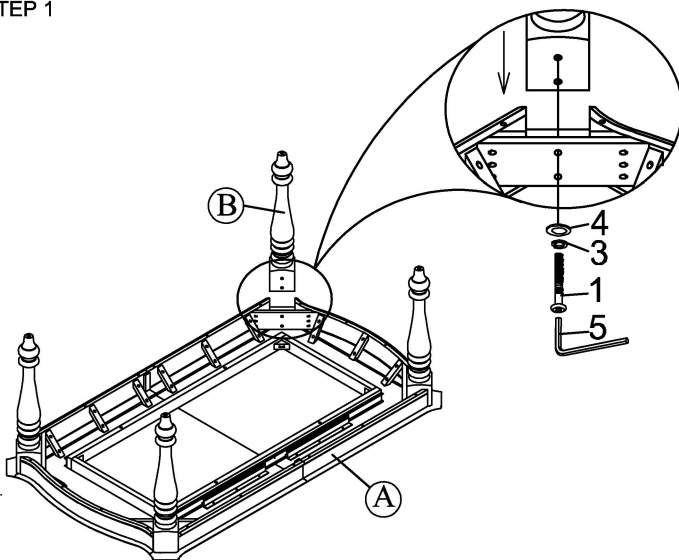

STEP 2

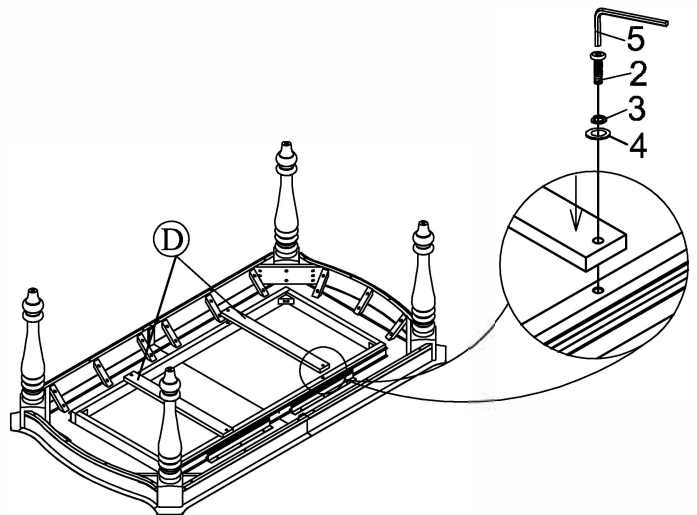

STEP 3

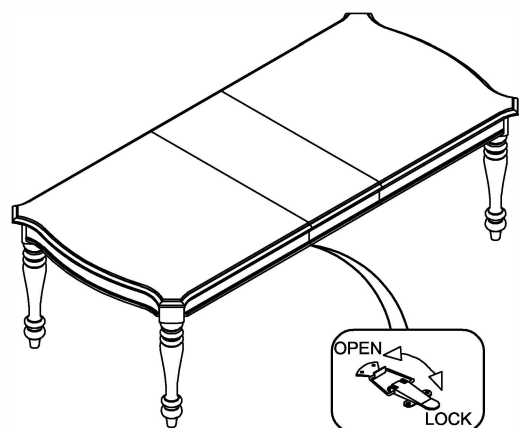
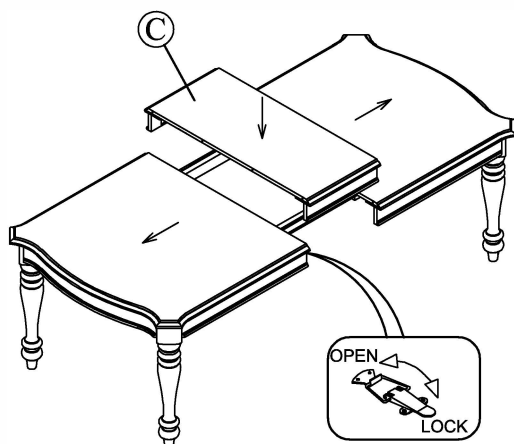

Note: Please DO NOT fully tighten all screws and bolts until the entire item is completely assembled

ASSEMBLY INSTRUCTIONS

DINING TABLE

Thank you for purchasing this quality product. Be sure to check all packing material care fully for small parts, which may have come loose inside the carton during shipment. Identify and count all parts and compare with the HARDWARE LIST below.

STEP 4

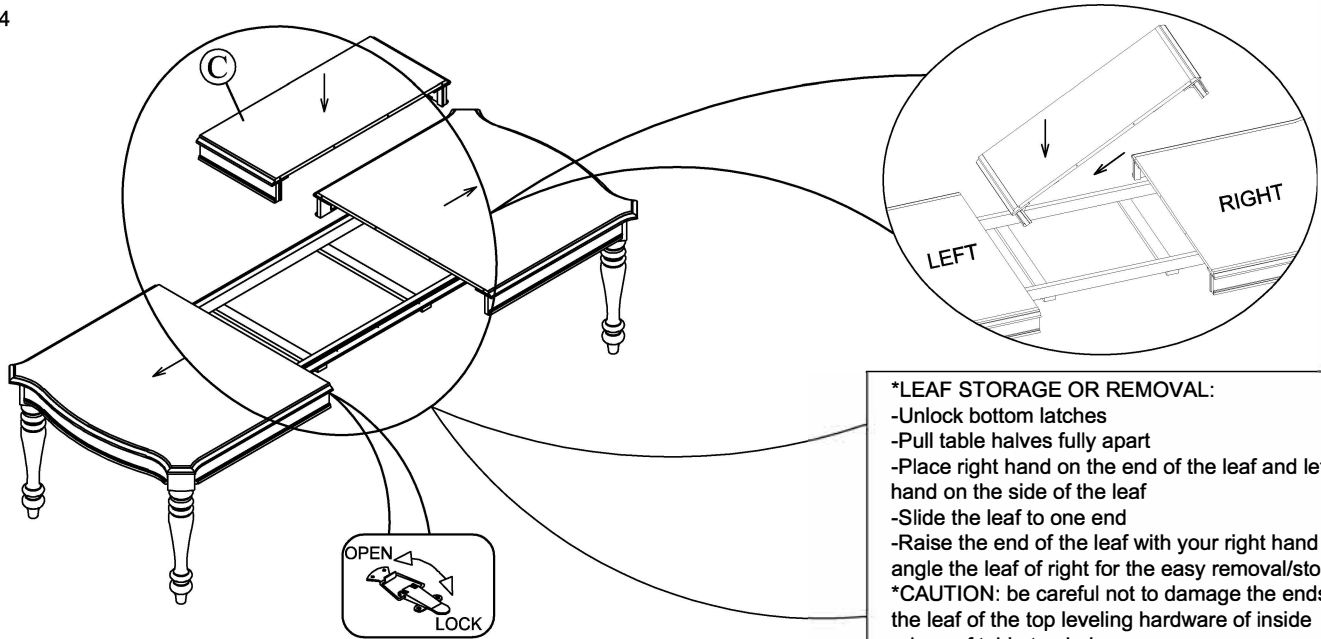

STEP 5

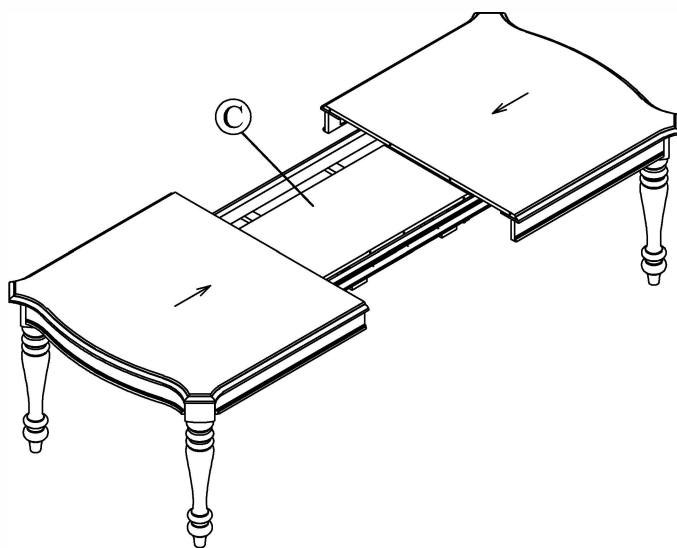

COMPLETED

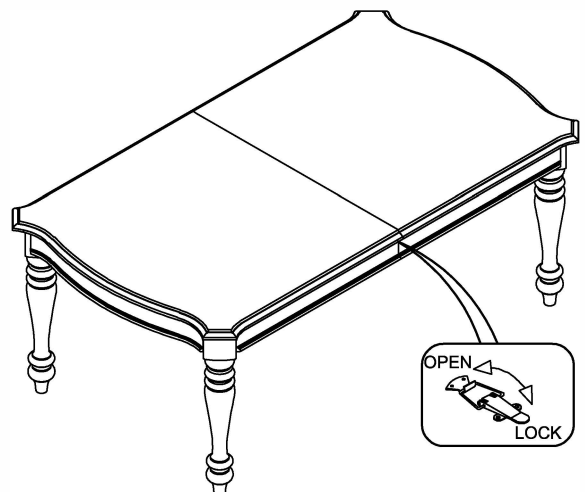

Note: Please DO NOT fully tighten all screws and bolts until the entire item is completely assembled