



FF642D



34" x 23.63" x 23.63" (H x W x D)

Two-drawer refrigerator in complete stainless steel for built-in or freestanding use

Highlights:

Flexible design allows built-in or freestanding use in 24" wide spaces

Complete stainless steel construction for luxury built to last

Digital controls offer easy and intuitive temperature management

Includes adjustable drawer dividers and removable basket for storage convenience

Product Features:

Built-in capable	Front-breathing design lets you make the best use of space by installing your appliance under the counter
Stainless steel exterior	Complete stainless steel construction ensures lasting durability and style
Two stainless steel drawers	Slide-out drawers offer 3.4 cu.ft. of interior storage
Digital thermostat	Electronic controls ensure easy temperature management, with an external readout in Celsius or Fahrenheit
Frost-free operation	No-frost operation for minimum user maintenance
Stainless steel kickplate	Completes the professional look down to the toe kick
Open drawer alarm	Audible alarm will sound if the drawers are left ajar for over a minute
Temperature alarm	High temperature alarm sounds if the unit's interior goes out of the recommended range
LED lighting	Elegant and efficient lighting offers a gentle illumination for the drawer interiors



SUMMIT APPLIANCE DIVISION FELIX STORCH, INC.

770 Garrison Avenue, Bronx, NY 10474 USA TEL 718-893-3900 FAX 844-478-8799

info@summitappliance.com



www.summitappliance.com



FF642D Specifications:

Overview	
Height	34.0"
Width	23.63"
Depth	23.63"
Depth with Handle	25.0"
Depth with door at 90°	39.38"
Capacity	3.4 cu.ft.
Defrost Type	Frost-Free
Door	Stainless Steel
Cabinet	Stainless Steel
US Electrical Safety	ETL
Canadian Electrical Safety	ETL-C
Sanitation	ETL-S
Energy Usage/Year	275.0kWh/year
Amps	0.8
Voltage/Frequency	115 V AC/60 Hz
Weight	106.0 lbs.
Shipping Weight	130.0 lbs.
Parts & Labor Warranty	1 Year
Compressor Warranty	5 Years
Refrigerator Features	
Reversible	No
Thermostat Type	Digital
Fan Type	Interior and Exterior
Refrigerant Type	R600a
Refrigerant Amount	0.99
High Side PSI	270.0
Low Side PSI	105.0
Level Legs Qty	2
Interior Light	Yes
Interior Drawers	Yes
Interior Drawers Qty	2
Dimensions	
Interior Height 1	9.25"
Interior Width 1	17.25"
Compressor Step Height	3.5"
Compressor Step Width	17.25"

Compressor Step Depth	4.0"
Drawer Dimensions	
Interior Depth 1	15.5"
Interior Height 2	10.0"
Interior Width 2	17.25"
Interior Depth 2	15.5"

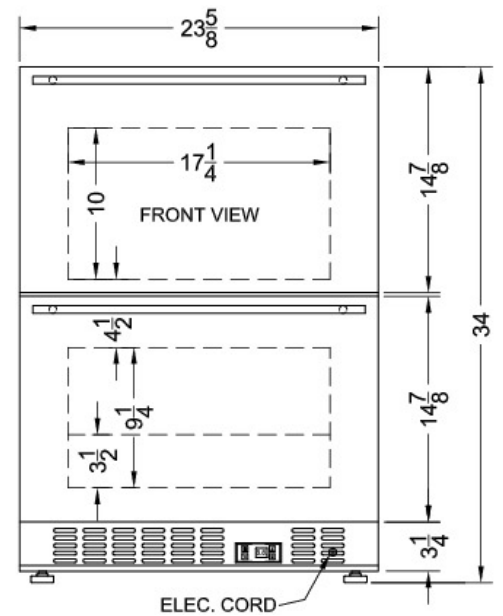
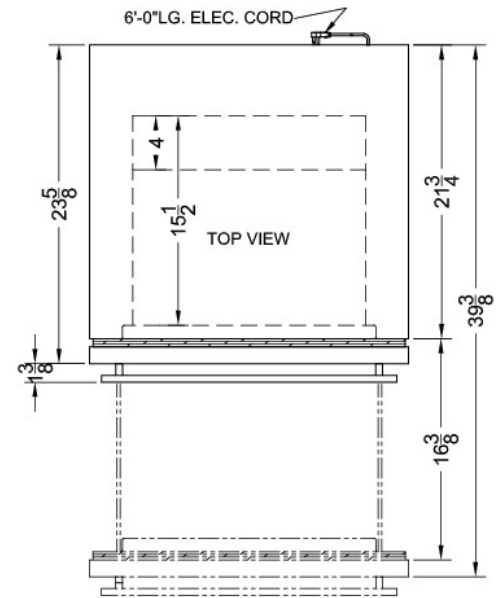

SUMMIT APPLIANCE DIVISION FELIX STORCH, INC.

770 Garrison Avenue, Bronx, NY 10474 USA TEL 718-893-3900 FAX 844-478-8799 info@summitappliance.com www.summitappliance.com