

“ Zero. Gravity Chair ”

USE AND CARE GUIDE
USE AND CARE GUIDE





Please kindly email: **Lounge-Chair@outlook.com**

Question about your product? We are here to help.



Chat Support



Product Inquiry



Product Inquiry



Product Assembly



Returns & Refunds

WHAT YOU GET

A

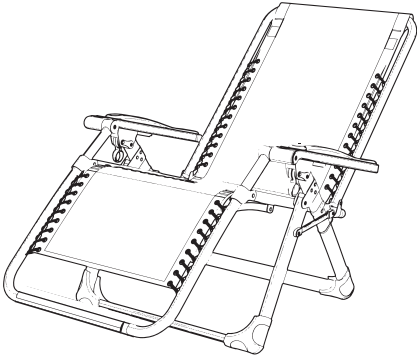

CHAIR x1

C



HEAD CUSHION x1

B

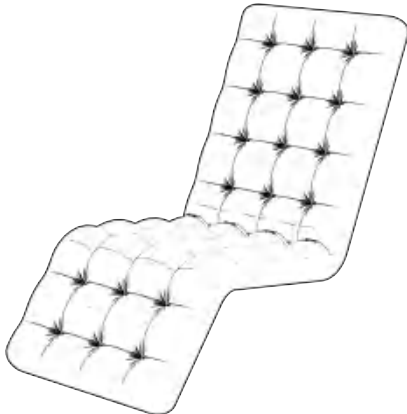

CUSHION SLEEVE x1

D

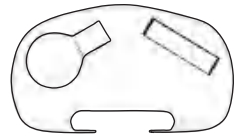

ACCESSORY TRAY x1

NOTE!

- 1.To avoid pinching, please do not put your fingers to the inside of the latch when you adjust to the angle.
- 2.To avoid tipping over, please do not sit in the backrest position.

WARNING

- Please use this chair for sitting purposes only; do not use it for any other activities.
- Exercise caution when folding and unfolding the chair to prevent pinching your fingers.
- When transporting, kindly fold the chair for ease and safety.
- Use the chair on a flat and stable surface for your safety.
- To prevent damage or tipping over, do not use the chair with more than two people simultaneously.
- Children should sit within the supervision of their guardians and should not use the chair alone. Infants and young children are not allowed to use it.
- Please be mindful of the slightly raised screw that secures the lock; refrain from touching it with your feet during use. When retracting the chair, take care not to catch any clothing material.

CARE AND GUIDE

- ① Avoid prolonged exposure to direct sunlight, heat, rain, and similar conditions, as it may result in deformation, discoloration, and rusting of the chair.
- ② Please take note that extended usage can cause scratches on the steel frame, frequent peeling, rusting, and corrosion of the coating. Additionally, exposure to water and sweat can lead to fading.
- ③ When cleaning, gently wipe with a mild, neutral detergent for decontamination.

INSTALLATION STEPS

1

Pull the part A chair open to spread the legs apart.

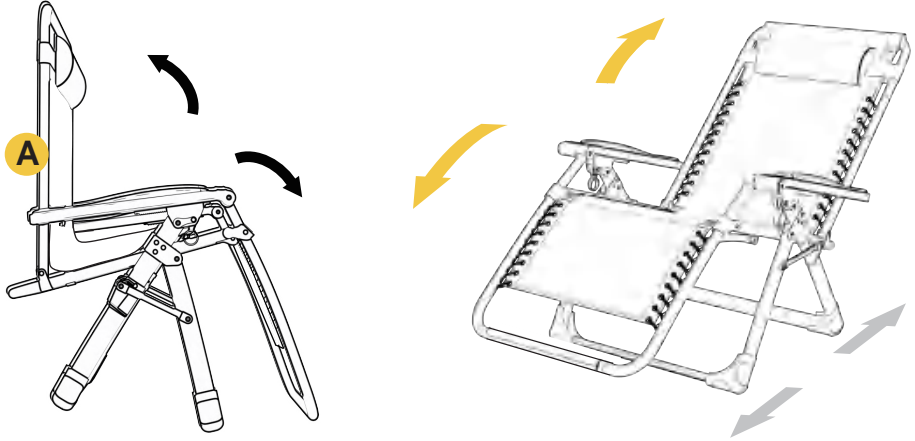

2

Lift the handles up on both sides and recline the chair. Push the handles back to lock the chair at your desired position.

3

To return to an upright position, lift handles up place a foot on the back chair leg, and push the backrest upright.

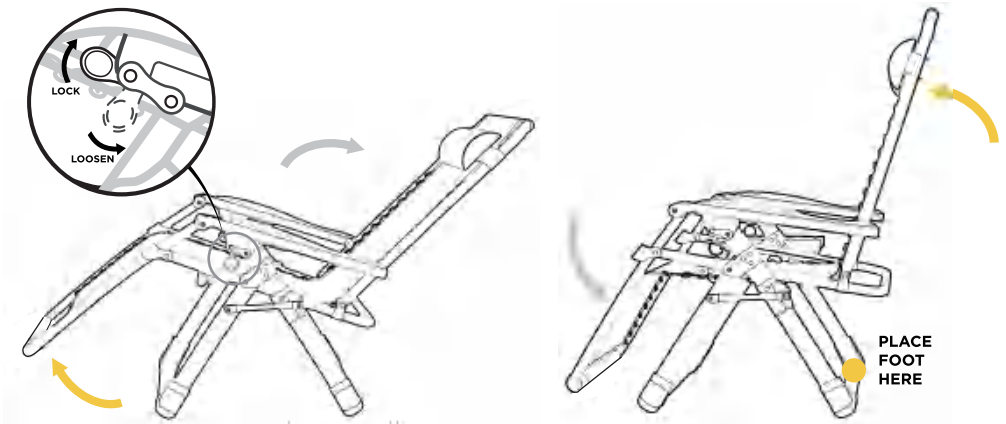

INSTALLATION STEPS

4

Remove the part C head cushion from the part A chair, then slip the part B cushion sleeve over the top of the chair, secure by tying the four straps to the chair frame. Replace the part C head cushion.

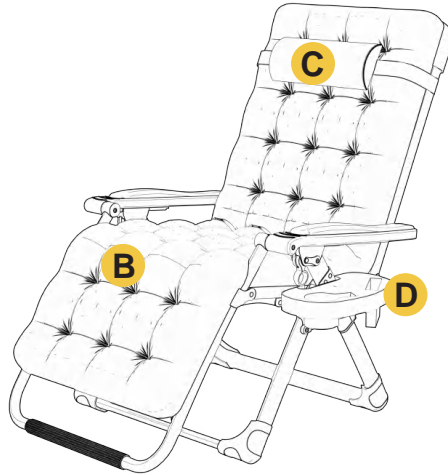
**5**

To install the part D accessory tray, slide the tray over the leg hinge and push down to lock it in place.

NOTE : REMOVE THE ACCESSORY TRAY BEFORE FOLDING THE CHAIR.

