

GENERAL INFORMATION

These installation specifications are for SPC by Ribadao Lumber & Flooring, LLC. All recommendations are based on the most recent available information. All instructions and recommendations must be followed for satisfactory installation. You may also visit Ribadao Lumber & Flooring, LLC for recent updates.

- Although acclimation is not specifically required, best installation practice recommends that the product be installed close to intended occupied service temperature, generally a target of 70° F (21°C), but at least between 55°F (13°C) and 100°F(38°C).
- SPC by Ribadao Lumber & Flooring, LLC is recommended for three season rooms and seasonal homes over concrete substrate. Installer must provide at least 5/8" (16mm) expansion.
- SPC by Ribadao Lumber & Flooring, LLC is not recommended where the floor might experience temperature extremes beyond -30°F (-34°C) or greater than 155° F (68°C). Occupied use temperature range is assumed to be between 55° (13°C) and 100° F (38°C).

-SPC by Ribadao Lumber & Flooring, LLC can be installed up to 50' x 50' (15.2 m X 15.2 m) or total of 2500 sq. ft. (232.3 sq m) with a (6.4mm) expansion. Larger areas must provide a 5/8" (16mm) expansion up to 100' x 100', (30.4 m X 30.4 m).

- Install SPC by Ribadao Lumber & Flooring, LLC only after the job site has been cleaned and cleared of other trade apparatus that may damage a finished installation.
- Mix and install product from several different cartons to achieve desirable plank variation.
- All sub-floors / underlayment's patching must be done with a non-shrinking, water resistant, high quality Portland cement patching compound.
- Structural sub-floor requirements must meet local building codes as well as Ribadao Lumber & Flooring, LLC criteria. For concrete subfloors, conformance to ASTM F 710 and for panel underlayment's conformance to ASTM F 1482.
- SPC by Ribadao Lumber & Flooring, LLC is designed to be installed as a Valinge 5G I lock locking system.

SUBFLOOR INFORMATION

- Careful and correct preparation of the subfloor is a major part of a satisfactory installation. SPC by Ribadao Lumber & Flooring, LLC is designed using a "floating floor" installation method. Although SPC will bridge minor floor imperfections and gaps; heavy roughness or unevenness in the subfloor may telegraph through the new floor covering.
- A sub-floor should be flat to within 3/16" (4.8 mm) in 10' (3048 mm) and 1/32" (0.8 mm) in 12" (305 mm).
- Never install SPC by Ribadao Lumber & Flooring, LLC products over residual asphalt-type (cut back) adhesive. Residual cut back adhesive should be completely removed and covered with high quality latex underlayment.
- SPC Ribadao Lumber & Flooring, LLC does not require an underlayment pad. It is important that the sub floor is clean and free from dirt or debris.

- Underlayment should meet the following criteria:
 - o 1.5mm maximum nominal thickness
 - o 6.5 #/ft³ (104 Kg/m³) minimum density
 - o >3 psi (20.7 kpa) at 0.020" (0.5 mm) compression on foam
 - o >50 IIC and minimum 250 psi (1724 kpa) static load as a finished floor assembly
 - o Where higher moisture levels are present, underlayment should incorporate moisture barrier properties, ASTM E96; water method of < 1 perm.

WOOD SUBFLOORS

- A wood floors must be suspended at least 18" (457.2 mm) above the ground. It is important to provide adequate cross-ventilation. Cover the ground surface of a crawl space with a suitable vapor barrier; Wood sub-floors directly on concrete or installed over sleeper construction are not satisfactory for installation.
- SPC by Ribadao Lumber & Flooring, LLC can be installed over many wood substrates that are not suitable for fully adhered products, if they are smooth, flat, structurally sound and free of deflection, including particleboard, chipboard, flake board, OSB. Caution: Damage may occur on wood panel sub-floors during construction. The suitability of these floors is the responsibility of the installer.
- If the surface of the wood sub-floor is not smooth, a 1/4" (6.4mm) underlayment panel should be installed over the sub-floor. Any panels selected as an underlayment must meet the following criteria:
 - o Be dimensionally stable.
 - o Have a smooth, fully sanded face so the graining or texturing will not show through.
 - o Be resistant to both static and impact indentation.
 - o Be free of any surface components that may cause staining such as plastic fillers, marking inks, sealers, etc.
 - o Be of uniform density, porosity and thickness.
 - o Have a written warranty for suitability and performance from the panel manufacturer or have a history of proven performance.

CONCRETE SUBFLOORS

- Concrete subfloors must be dry, smooth, and free from dust, solvent, paint, wax, grease, oil, asphalt sealing compounds and other extraneous materials. The surface must be hard and dense and free from powder or flaking.
- Surface of the slab should be flat to within 3/16" (4.8 mm) in 10" (3048 mm) and 1/32" (0.8 mm) in 12" (305 mm).
- New concrete slabs must be thoroughly dry (at least six weeks) and completely cured.
- All concrete slabs must be checked for moisture before installing material. Details for moisture testing can be found on our website. The final responsibility for determining if the

concrete is dry enough for installation of the flooring lies with the floor covering installer: SPC by Ribadao Lumber & Flooring, LLC must never be installed where excessive moisture emissions may exist. In accordance with ASTM F1869 moisture emission from subfloor cannot exceed 8 lbs. MVER (moisture vapor emission rate) per 1,000 sq. ft. per 24 hours as measured with the calcium chloride test or ASTM F 2170 In Situ Relative Humidity test not to exceed 85%. Ribadao Lumber & Flooring, LLC will not assume responsibility for floor covering failure due to hydrostatic pressure or excessive moisture vapor emission. New concrete slabs must be thoroughly dry (at Least six weeks) and completely cured. Although the planks are not susceptible to damage from moisture, excessive subfloor moisture can be a breeding ground for mold, mildew and fungus. All of which can contribute to an unhealthy indoor environment. The Limited Warranties do not cover issues arising from flooding, leaking plumbing or appliances, water entering through sliding glass doors, presence of mold, discoloration from mold or fungi or similar conditions.

- Holes, grooves, expansion joints and other depressions must be filled with a high-quality cementitious patching & leveling compound, troweled smooth and feathered even with the surrounding surface.
- Concrete floors with a hydronic radiant heating system are satisfactory, provided the temperature of the floor does not exceed 85°F at any point. Before installing the flooring, the heating system should be turned on to eliminate residual moisture. Ribadao Lumber & Flooring, LLC does not recommend heated floor mats for SPC Ribadao Lumber & Flooring, LLC.

EXISTING FLOOR COVERINGS

- SPC by Ribadao Lumber & Flooring, LLC can also be installed over most existing hard-surface floor coverings provided that the existing floor is well bonded, and the surface is flat and smooth.
- Ceramic tile unevenness should be made smooth by applying an overlay such as cementitious patching or leveling compound.
- Existing floors should not be heavily cushioned and not exceed one layer in thickness.
- Do not install over carpet.
- Floor should be flat, smooth, dimensionally sound and free from deflection.

INSTALLATION

- SPC by Ribadao Lumber & Flooring, LLC is designed to be installed as a "floating" floor. Do not secure the planks to the subfloor; Always undercut wood doorjamb. Check local building code for metal door jamb. If they cannot be cut, then proper expansion must be maintained around door jamb. Do not install cabinets or kitchen islands on top of SPC by Ribadao Lumber & Flooring, LLC Use care when installing wall moldings and transition strips to not fasten through the product. SPC by Ribadao Lumber & Flooring, LLC is a drop and lock product. Please see illustration below on proper install technique.

DIAGRAM OF SPC INSTALL

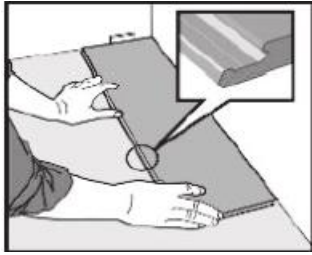

Fig 1. First plank, first row. Place a spacer of 3/8" thickness to the left and position the plank against the wall. Later, after 3 rows, you can easily position the flooring against the front wall with distances « 3/8".

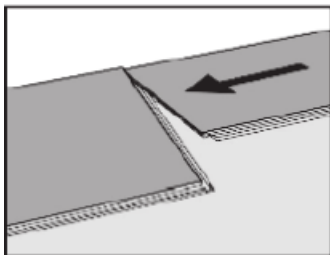

Fig2, Second plank, first row. Place this plant gently and tight to the short end of the first one.

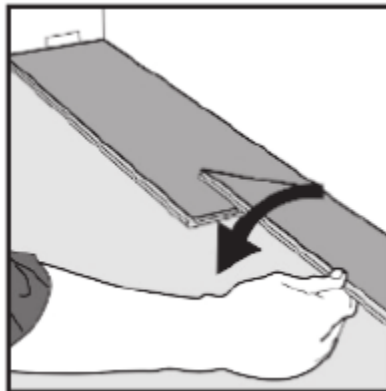

Fig3, Fold the panel down in a single action movement. During the fold down, make sure the panels are tight against each other. Afterwards, place down or slightly tap down at the short end just installed it till it clicks. No major force is required.

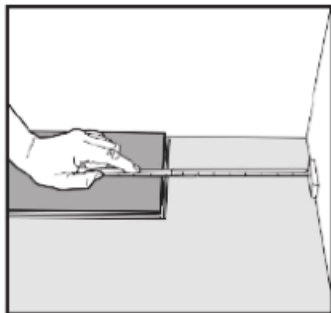

Fig4, at the end of first row, put a space 3/8" to the wall and measure the length of the last plank to fit.

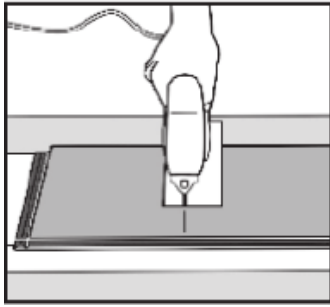

Fig5, cut with a jig saw - hardwood face turned down to eliminate/ reduce damage to the face panel. Or if cutting using a hand saw, chop saw or guillotine cutter; cut it with the hardwood visible face up. Then install it as previous plank. A utility knife can also be used for straight cuts. Score the face several passes using a speed square as a guide. Then snap the flooring- similar to scoring and snapping drywall.

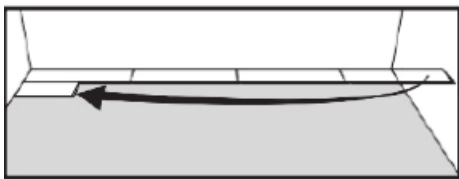

Fig6, starting the second row. The first plank should be a min length of 10". Put a 3/8" spacer against the wall and measure the last piece. If it is shorter than 10", a new starter piece should be used. Insert the plank at the angle into the previous row and tap (on the long side) it in by using a tapping block till flat.

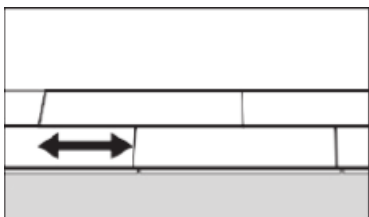

Fig7, General distances between short ends. Minimum distance between short ends of planks in parallel rows should not be less than 6".

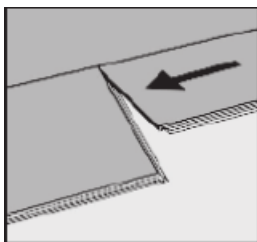

Fig8a, second plank, second row place the panel at an angle into the groove of the previous row making sure that the end of the panel is tight/flush to the short end of the previous panel.

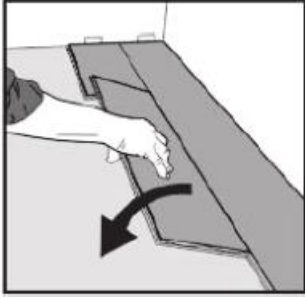

Fig8b, Fold the panel down in a single action movement with a slight press to the left to the short end of the previous panel. Again, using the tapping block tap it against the long end into the previous row. During the fold down, make sure the panels are tight against each other.

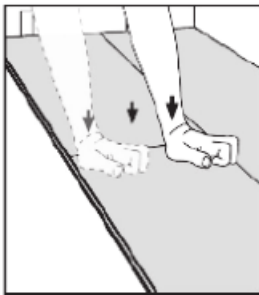

Fig8c, As the board flattens itself to the floor; press or gently tap the top of the short end of the installed panel until it is locked. It is recommended that a soft face rubber mallet be used for tapping. The product is properly locked when the two boards are flush across the top. Finish installing this plank by tapping it with a tapping block on the long side to ensure secure installation.

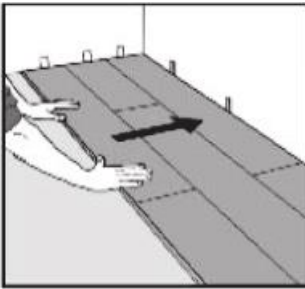

Fig9, After 2-3 rows. Adjust the distance to the front wall by placing spacers 3/8" on the side walls and the end wall. Once the adjustment is done against the main wall, continue to install till the last row.

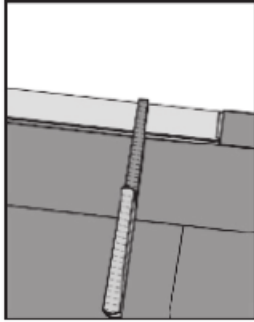
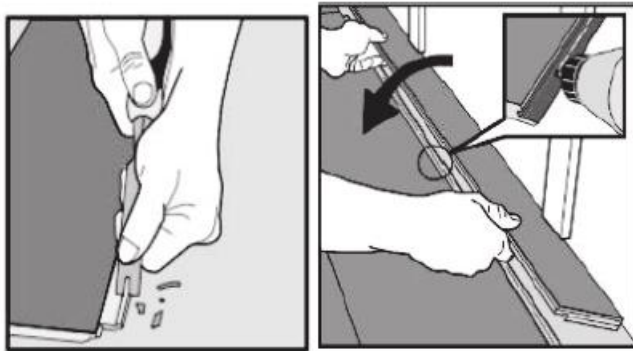

Fig10, Last row (and perhaps also first row). The Minimum width of the

last plank should be NOT LESS than 2^M wide. Remember distance to wall is 3/8". Tip! Put a spacer before measuring Cut the panels lengthwise and glue the short ends. See instructions below.



Special installations - Small panel widths.

Joining at short ends length cut panels. Cut the tongue at the same time you cut the length of the panel and install as shown above. Please note that the smallest width of a panel is 2" at the last row. If it is not, the first-row width must be adjusted. This can easily be calculated when measuring the room with before installation. Cut off the locking element with a chisel, push the planks horizontally together If necessary, place some spacers between the last panel and the wall to keep the planks together during the curing time of the glue.

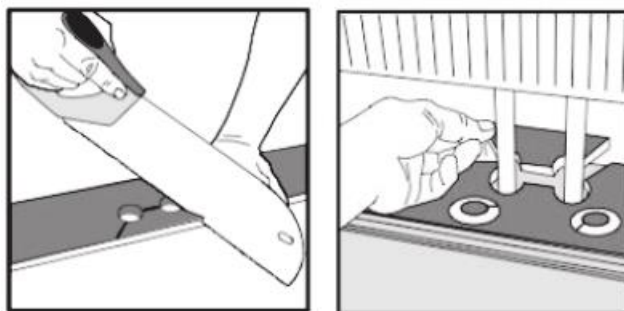

Radiator pipes, installation at

radiators.

Drill the holes larger than the diameter of the pipes. Cut out the panel (with the thinnest blade possible) as per diagram. Install the plank as per normal. Glue the cut-out piece back again.

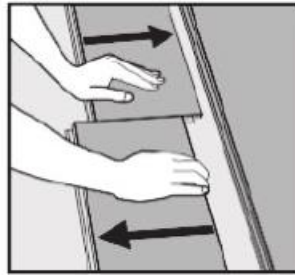
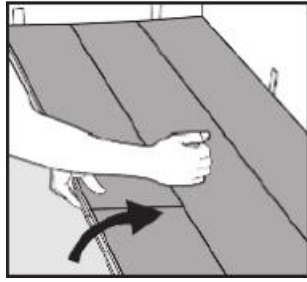

Disassembling

Your floor can very easy be disassembled, which enables replacement during installation and also during use. Fig 11. Separate the whole row by carefully lifting up and slightly knocking just above the joint. Fold up and release the whole long side. Fig 12. Disassemble the panels by sliding horizontally. (Do not fold up!)

FINISHING THE JOB

- Protect all exposed edges of SPC by Ribadao Lumber & Flooring, LLC by installing wall base and/ or matching moldings. Use caution to prevent the fasteners from securing the planks to the subfloor. Do not allow the floor to become pinched. Considerations for transitions should be made for substrate changes, room to room environment changes, complicated layouts, and subfloor elevation. Caulk along tubs, toilet bowls, etc.
- After 48 hours, damp mop to remove residual surface dirt. Follow appropriate maintenance schedule using a quality rinse free cleaner.

REPAIRS

- SPC by Ribadao Lumber & Flooring, LLC is tough and durable, however; if a plank becomes damaged it can be replaced.
- If the damaged plank is along the perimeter of the room, the easiest technique is to just disconnect the planks until the damaged plank is removed. Replace the material and reassemble the planks.
- If it is impractical to just disconnect and reassemble the flooring, follow this procedure:
 - Using a circular saw and or a multi tool saw, cut out and remove the center of the damaged piece, leaving approximately a 1" (25.4mm) strip attached to the surrounding material.
 - Carefully cut back from the corners of the plank or tile to the inside edge.
 - Remove the edges by wiggling the cut plank out from the tongue and groove of the surrounding pieces.
 - Prepare the replacement plank by removing the leading edge of the tongue profile on the long side and the end of the plank. Careful not to damage the decorative surface. Also remove the bottom of the groove on the short end side by cutting on an angle to remove. Once the plank is prepared, install groove into tongue to test the fit. Once you check the fit is correct you are now ready to complete the install.
- Position the replacement piece by engaging the groove into the tongue of the adjoining material "Hinge" the prepared replacement plank into position.

- Slightly lift prepared side of plank and apply a thin application of MSS 20 (Order Code: 832202) or MCS 42 (Order Code: 849832) onto the three exposed seams and carefully position plank into place, wipe excess from surface.
- Use a hand roller to assist in aligning the edges into position.
- Weight the replaced plank for at least 15 minutes until the sealer secures the material.

CAUTIONS AND MISCELLANEOUS

- Furniture should be moved onto the newly installed floor using an appliance hand truck over hardboard runways.
- Heavy furniture should be equipped with suitable non-staining, wide-bearing casters or protectors. Non-staining felt protectors are recommended for table and chair legs to help prevent scratching.
- Like with all floor coverings, it is best to protect SPC by American Luxury Vinyl installation from exposure to direct sunlight. A combination of heat and sunlight can cause most home furnishings to fade and discolor; Avoid exposure to direct sunlight for prolonged periods. During peak sunlight hours, the use of blinds or drapes is recommended.
- Oil or petroleum-based products can result in surface staining. Do not track asphalt driveway sealer or automobile-oil drips onto the SPC by American Luxury Vinyl.
- Use rugs or mats labeled “non-staining” that provide a manufacturer warranty.