

Components

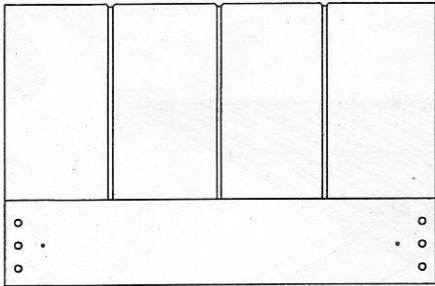

Headboard **1**

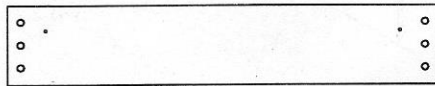

Footboard **2**

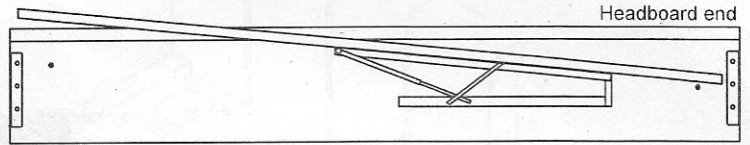

Left side rail **3**

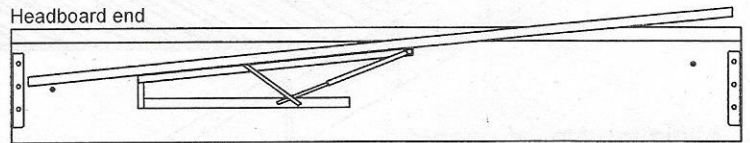

Right side rail **4**

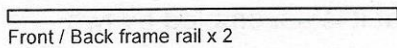

Front / Back frame rail x 2 **5**

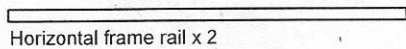

Horizontal frame rail x 2 **6**

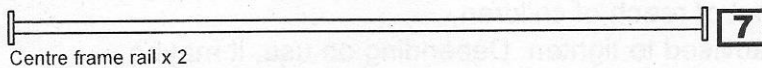

Centre frame rail x 2 **7**

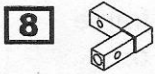

Plastic bracket sets x 4 **8**

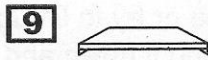

Corner brackets x 4 **9**

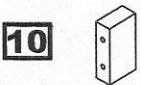

Holding blocks x 3 **10**



Plastic legs x 4 **11**



Belt x 1 **12**

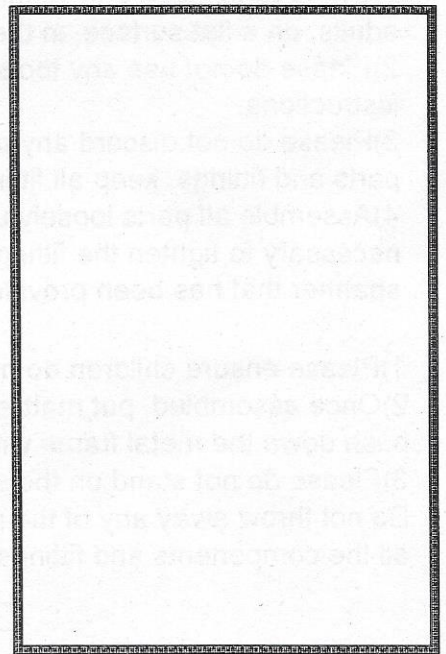

Woven fabric x 1 **16**



Bent slats x 45 **13**



Side slat caps x 30 **14**









Centre slat caps x 30 **15**

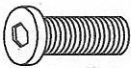

metal plate X2 **17**

53 x 585

Components - Fittings

<p>A  25mm M8 Bolt x 12</p>	<p>B  15mm M6 Bolt x 16</p>	<p>C  40mm M6 Bolt x 8</p>
<p>D  Flange nut x 2</p>	<p>E  75mm M6 Bolt x 6</p>	
<p>F  Spring washer x 12</p>	<p>G  Flat washer x 12</p>	

Tools required (supplied)

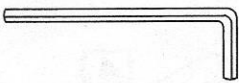

5mm Allen key x 1

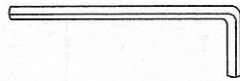

4mm Allen key x 1



Spanner x 1

Assembly Instructions

Step 1:

Attaching side rails

A: Position left side rail(3) adjacent to headboard(1) so that the holes in the headboard line up with the bracket on the side rail. Secure in place using 3 bolts(A), spring washers (F) and flat washers(G) using the allen key provided.

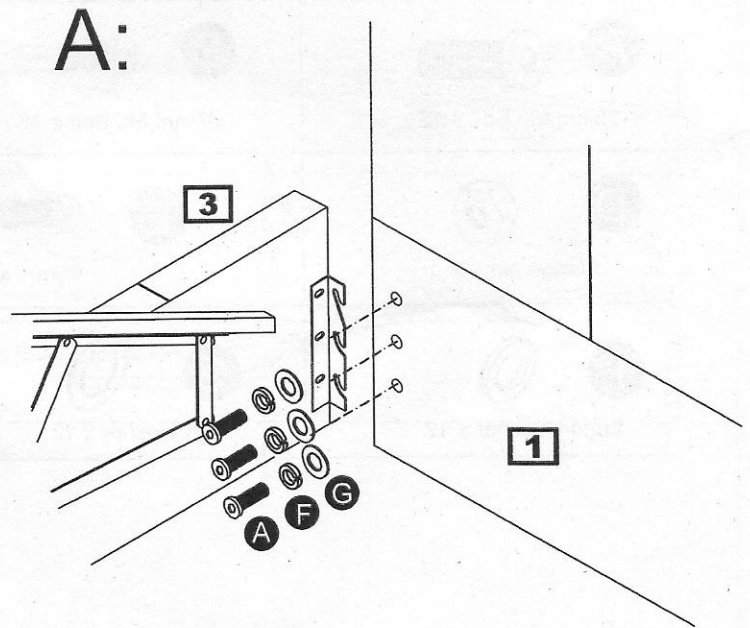

B: Repeat point a for right side rail(4).

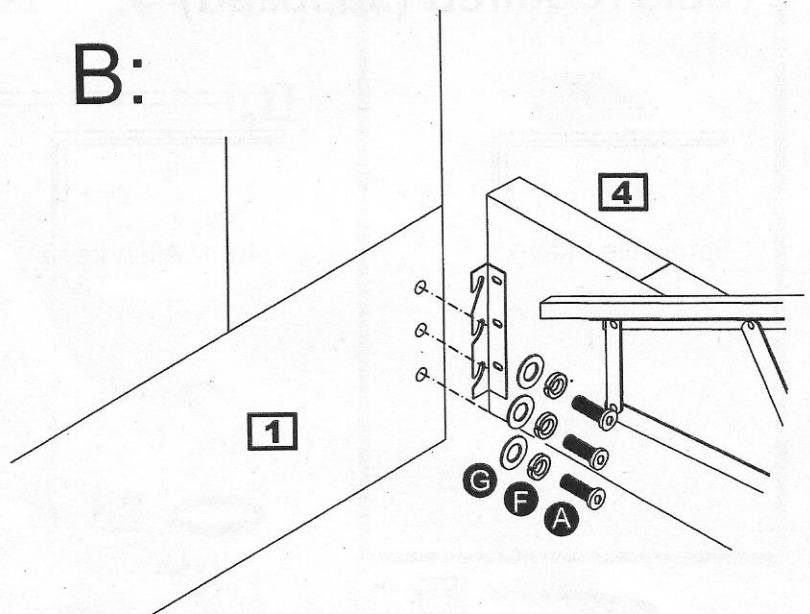

Assembly Instructions

Step 2:

Attaching footboard

Place footboard (2) in position at the end of the side rails (3) & (1) so the holes in the footboard line up with the brackets on the side rail.

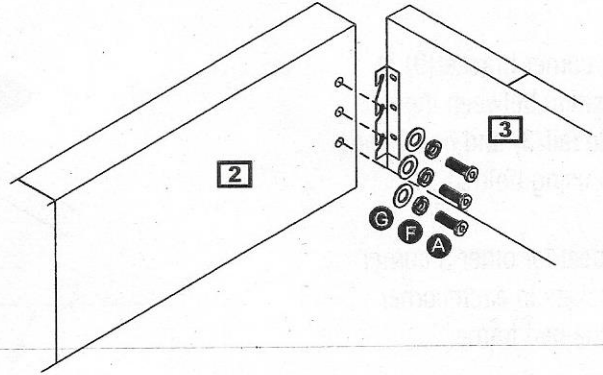

Secure in place using 3 bolts (A), spring washers (F) and flat washers (G) using the allen key provided.

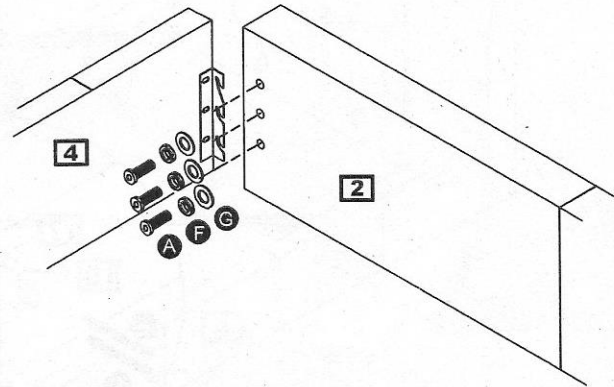

Before tightening the bolts, please ensure the bed frame is square.

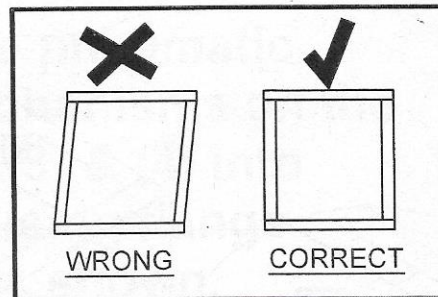

Assembly Instructions

Step3:

Fix corner brackets

Fix corner bracket(9) in position between the left side rail(3) and headboard (1) using bolt(B).

Repeat for other 3 corner brackets in each corner of the bed frame.

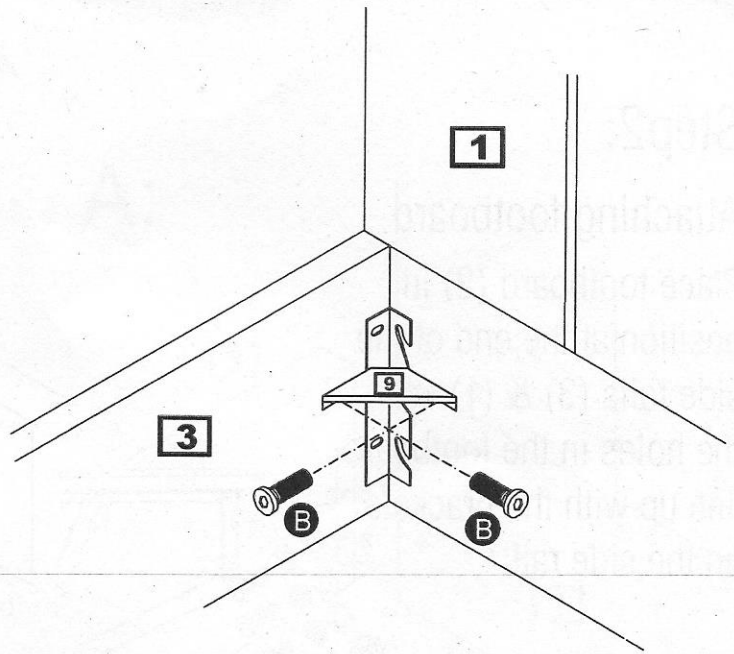

Step4: A) Fix holding block(10) onto footboard (2) using bolt (E) and tighten using allen key .
B) Fix holding block (10) with metal plate (17) using bolt(E) and tighten using allen key.

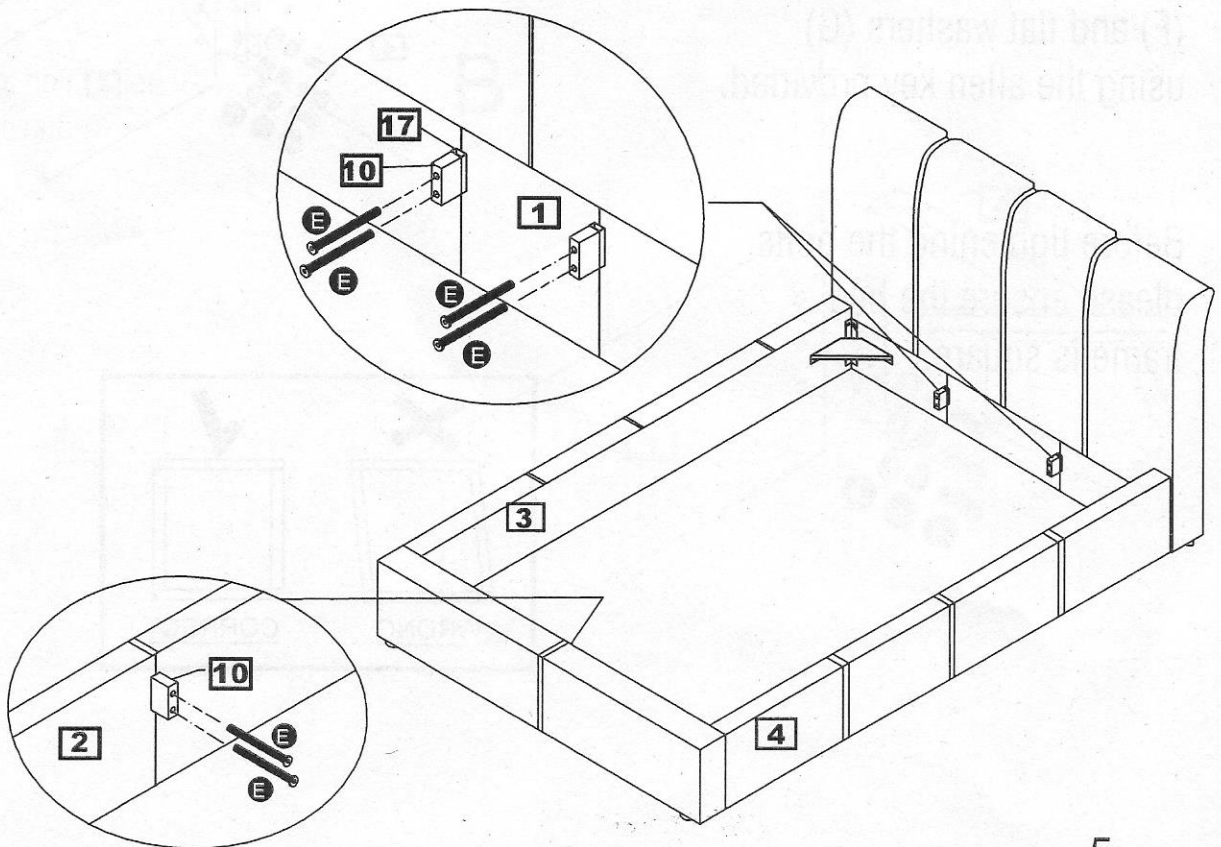

Assembly Instructions

Step 5:

Secure pneumatic arms

Before connecting the pneumatic arms, ensure the lifting mechanism is functioning correctly - it should lift up and down freely with adequate clearance on all sides.

Please ensure the pneumatic arm is the correct orientation. The thinner section should be attached to the side rail, and the thicker part is connected to the slat frame.

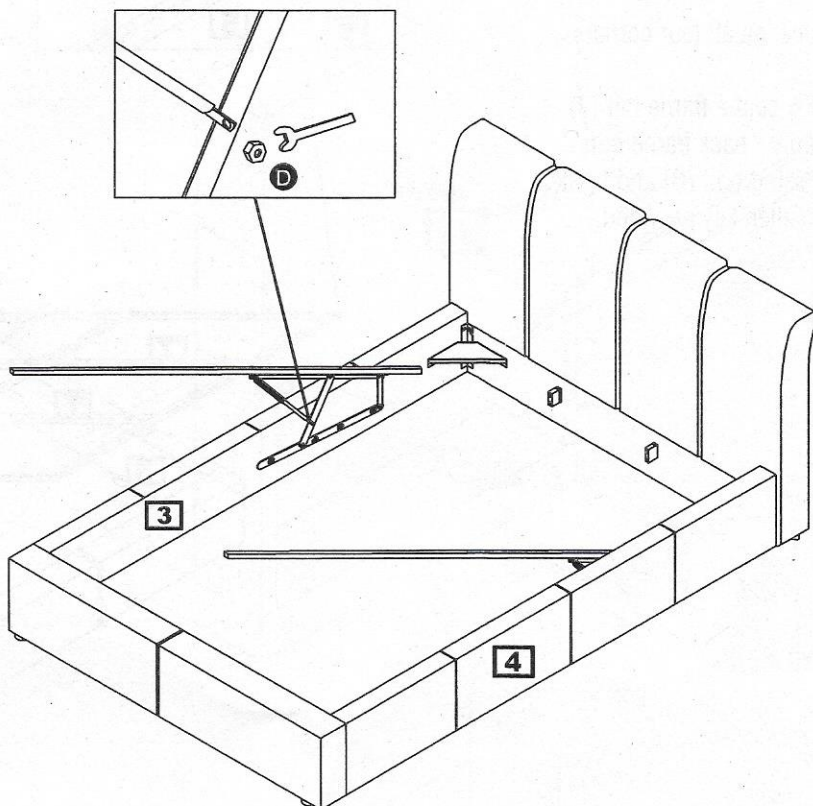

secure the pneumatic lifting mechanisms on the side rails (3) & (4) into place by using flange nuts (D) as shown.

Do not overtighten the nuts.

Assembly Instructions

Step6:

Assemble slat frame

A: Fix the front/back frame rails(5) to the side support rails which are already attached to the lifting mechanism with plastic brackets (8) .

Repeat on all four corners.

B: Fix centre frame rail (7) to front / back frame rails (5) using bolt (B) and tighten with allen key provided.

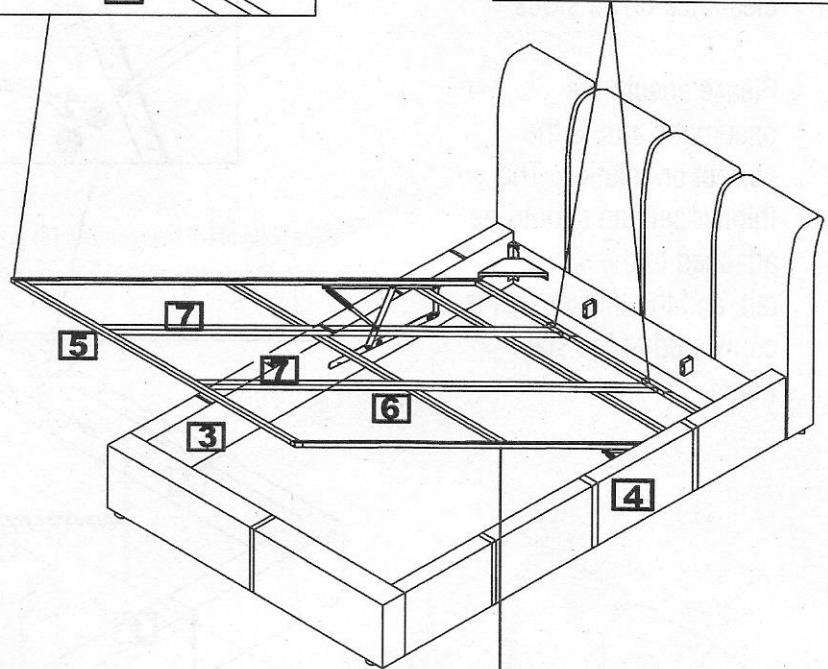
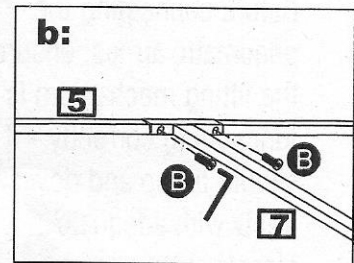
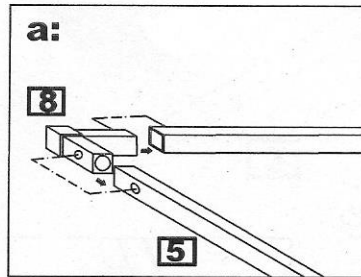

Step7:

Attach the horizontal supports

Fix the horizontal support rails (6) on the bottom of the lifting mechanism rail using bolts (C) with the allen key provided.

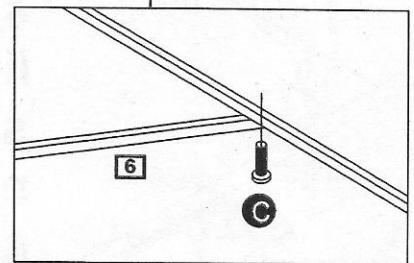

Assembly Instructions

Step 8:

A: Attach woven fabric

Turn bed on its side and attach woven fabric (16) to base.

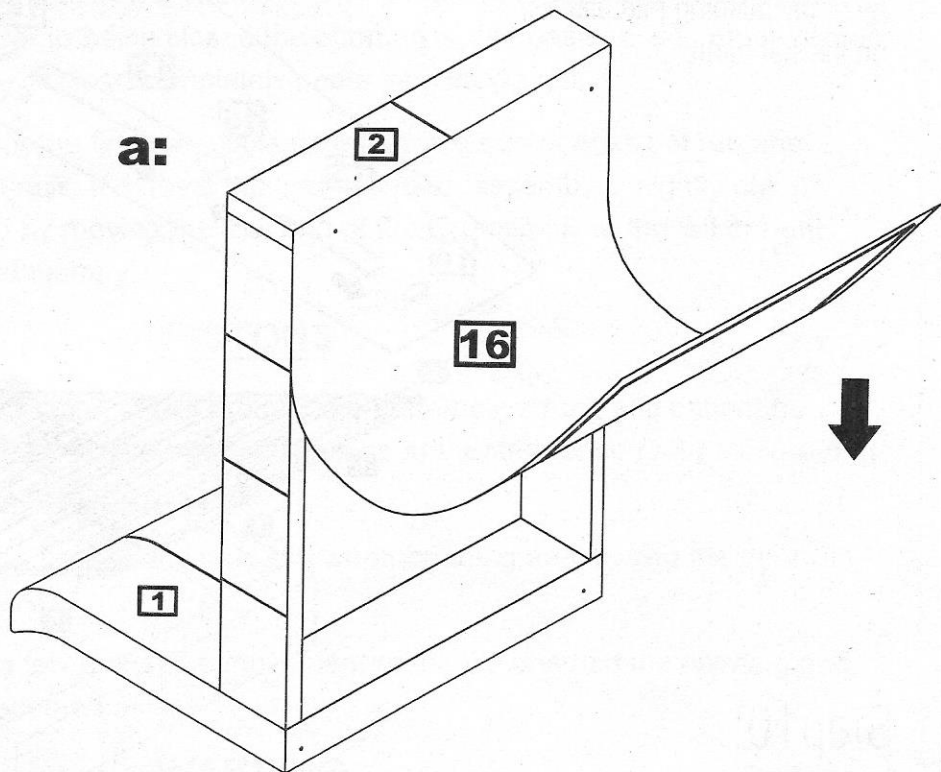

B: Attach plastic legs

Whilst bed is upside down attach plastic legs (11) using bolt (C) to the base and tighten using allen key provided.

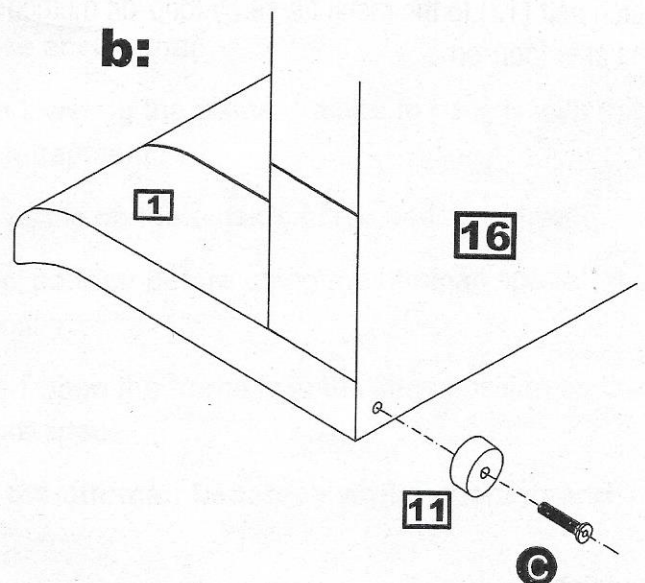

Assembly Instructions

Step9: Assemble slats

Attach centre slat caps (15) and side slat caps (14) to each slat (13) as shown.

Attach the slats to the slat frame by firmly pushing into place on the slat frame.

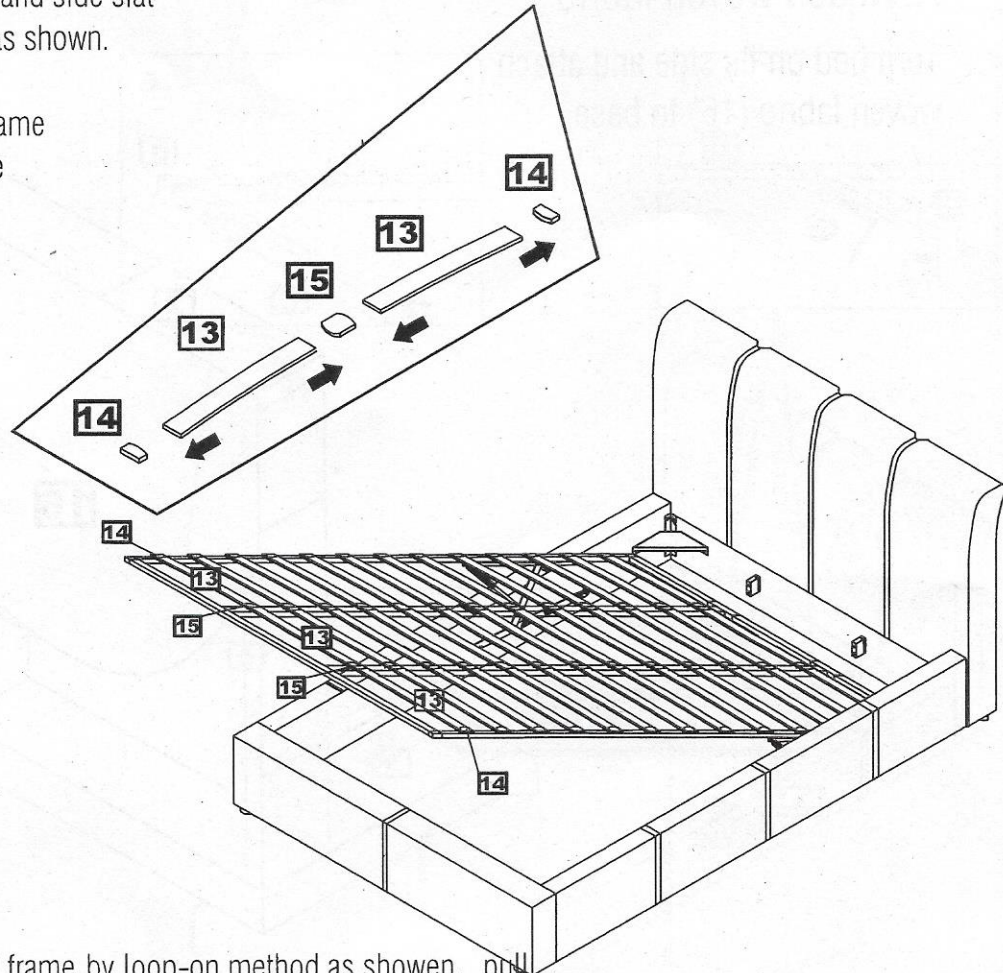

Step10:

Attach belt (12) to the metal frame by loop-on method as shown. pull tight after loop-on.

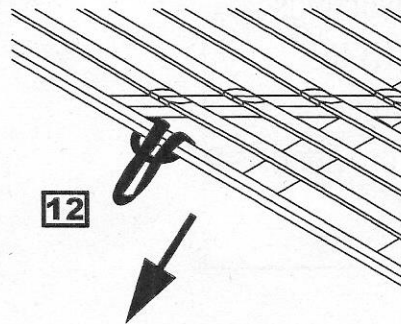

IMPORTANT NOTICE

OTTOMAN OPERATING INSTRUCTIONS

Once your bed frame is completely assembled the slat unit will not operate correctly unless a mattress is placed on the slat frame. Position the mattress on the slat frame whilst it is in the closed position.

Operate the cloth handle to open and close the ottoman. PLEASE NOTE - it takes a lot of force to make the initial movement of the ottoman. This is a design feature of the product so it does not fall shut - the nearer to being closed the ottoman is, the easier it is to move. When the ottoman is almost shut it will close completely under its own weight.

When lowering the slat unit for the first time, take care to make sure it does not rub unevenly on the inside face of the side rails. If it does, the bed has been assembled slightly out of square. This can be reflected by moving the foot end of the bed slightly to the left or right whilst leaving the head end stationary.

PISTONS

The pistons used in the construction of this product are extremely strong and cannot be operated by hand when taken off the ottoman. All pistons are tested for correct pressure and operation before being attached to the slat unit.

Initially it might appear that the pistons are very stiff when opening and closing the ottoman - THIS IS PERFECTLY NORMAL

After operating the ottoman a few times, the movement of the pistons and the opening and closing of the ottoman will become easier.

WARNING

For the safety of yourselves and others, please ensure that:

- Only the handle is used when lifting and lowering the frame. Failure to comply with this warning may result in injury and finger entrapment.
- The handle is attached and always left visible on the outside of the bedstead frame.
- The metal frame is fully raised in the 'Up' position before using the ottoman space, otherwise the frame could fall causing injury.
- Children and pets are not left unattended when the frame is in the lifted position as they could become trapped inside the ottoman space.

Please keep children and pets away from the ottoman bedstead whilst opening and closing the slat frame to avoid injury.