

# SPIGOT HANDLE WITH PLUG HOOK KIT (2-PACK)

NEED HELP OR ADVICE ON PUTTING THIS KIT TOGETHER? MISSING  
PIECES? EMAIL US AT OUR WEBSITE FOR ANY QUESTIONS

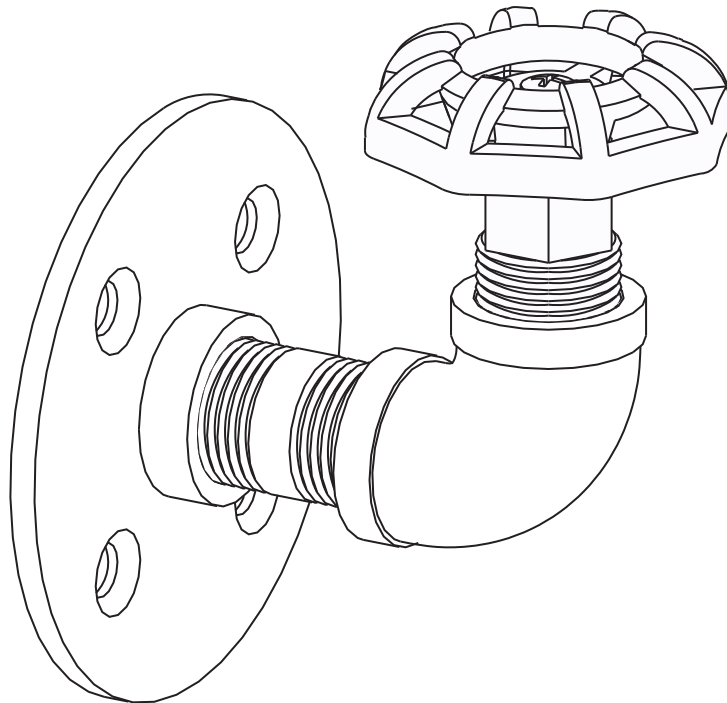

## HOW TO PREVENT PIPE CORROSION

Our industrial-grade black pipes and fittings are coated with a rust-preventive oil during manufacturing. For best results, **SEAL THE PIPES TO AVOID ANY RUSTING** after cleaning the kit.

### **CLEAN AND SEAL INSTRUCTIONS:**

**CLEAN:** Recommended supplies: regular degreasing dish soap, washcloths, gloves (optional)  
1. Wash your pipes and fittings with warm water and dish soap until the oil is completely removed.  
2. Wipe the pipes with a dry washcloth and wait until the pipes are completely dry.

**IMPORTANT: THE PIPES MUST BE COMPLETELY DRY BEFORE YOU START THE SEALING PROCESS.**

### **SEAL:**

**IF USING POLYURETHANE SPRAY:** Spray each dry pipe and fitting with a polyurethane matte or satin finishing spray and let it dry before assembling the kit.

**IF USING FINISHING WAX:** Coat each dry pipe with a finishing wax. Wait for 20 minutes, then polish the pipe with a dry washcloth by wiping them down. Faster wiping will result in a shinier finish.

# SPIGOT HANDLE WITH PLUG HOOK KIT (2-PACK)

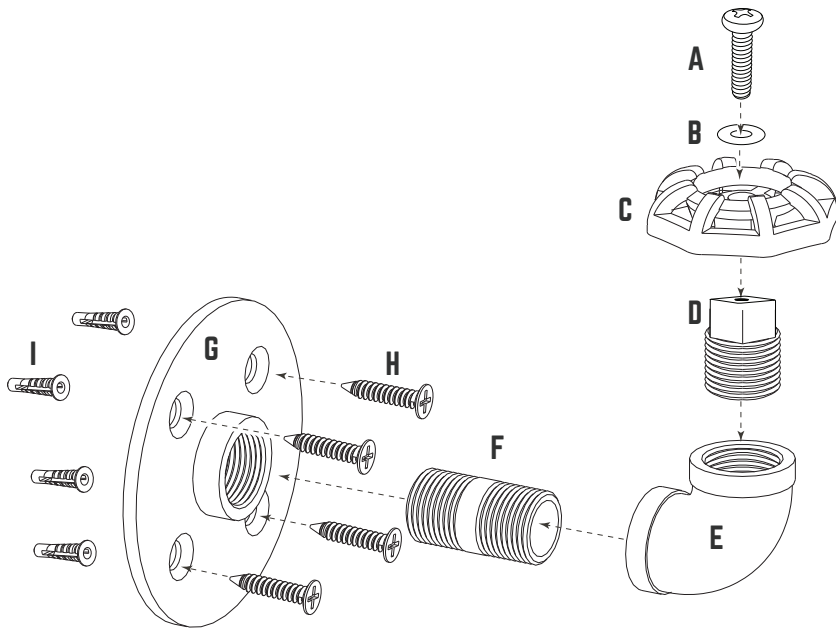

PART	DESCRIPTION	QTY
A	MACHINE SCREW	2
B	WASHER	2
C	SPIGOT HANDLE	2
D	THREADED PLUG	2
E	90° ELBOW	2
F	1.5" NIPPLE	2
G	1/2" FLANGE	2
H	SCREWS	8
I	ANCHORS	8

## EASY INSTALLATION:

### RECOMMENDED TOOLS FOR INSTALLATION

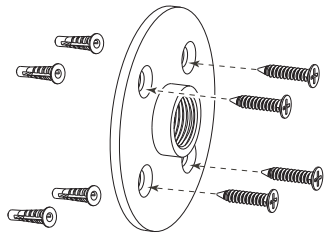
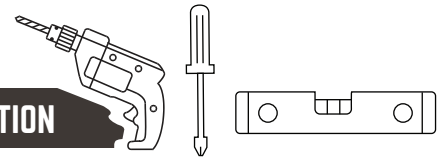

#### STEP 1

- Place flange against wall in desired location and mark holes with pencil
- Using stud finder, locate and mark wall stud if found
- A) If a wall stud is present, attach flange to wall with included screws
- b) If no wall stud is present:
  - Drill pilot holes in wall using 1/4" drill bit
  - Insert anchor fully into pilot hole using hammer and Phillips screwdriver as needed
  - Attach flange to wall using included screws

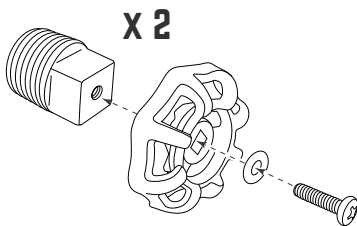

#### STEP 2

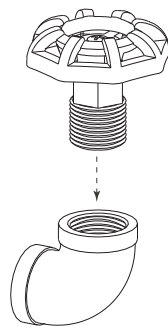

#### STEP 3

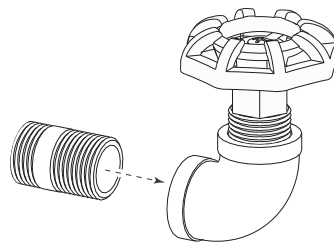

#### STEP 4

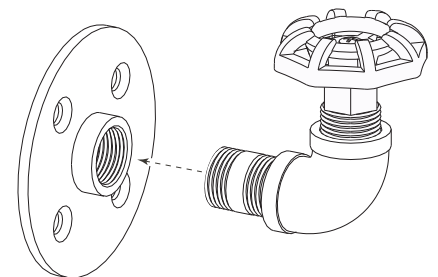

#### STEP 5