

# Montageanleitung | Instructions de montage Assembly Instructions | Instructions de montage

N616P373598W  
N616P373599W  
N616P373600W  
N616P373601W

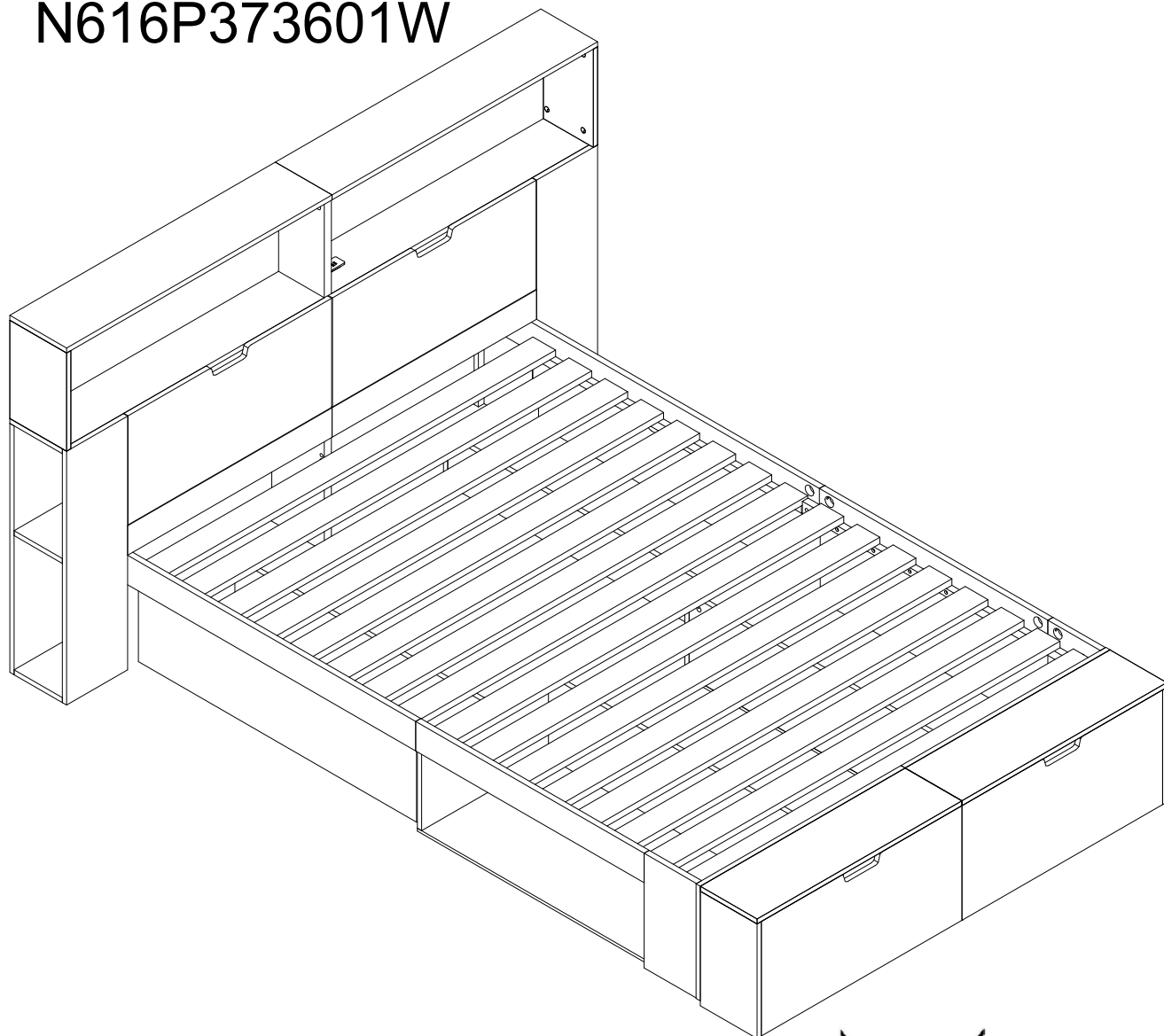

Points de collecte sur [www.quefairedemesdechets.fr](http://www.quefairedemesdechets.fr)  
Privilégiez la réparation ou le don de votre appareil !



**(GB)** This set comes in 4 boxes. If you do not receive a full set of 4 boxes, please contact our customer service.

**(DE)** Dieses Set wird in 4 Schachteln geliefert. Wenn Sie nicht ein komplettes Set von 4 Boxen erhalten, kontaktieren Sie bitte unseren Kundenservice.

**(FR)** Ce set est livré en 4 boîtes. Si vous ne recevez pas un jeu complet de 4 boîtes, veuillez contacter notre service clientèle.

## English

### IMPORTANT ! KEEP FOR FUTURE REFERENCE : READ CAREFULLY

- To be assembled by an adult. Assembly must be checked by an adult before use
- WARNING ! Keep all screws, small parts and plastic bags out of the reach of children
- Properly identify all parts before assembling
- Never use your item if any of its parts are broken or missing
- Should any problems arise, please contact our After Sales Service
- Manufacturer's instructions shall be followed at all times
- Care: Clean with a soft, dry cloth. In case of larger stains, carefully rub with a slightly damp, non-abrasive sponge
- Avoid the risk of fire by not placing furniture near sources of ignition or hot items
- Do not jump on the bed

## Deutsch

### WICHTIG ! ZUM SPÄTEREN NACHSCHLAGEN AUFBEWAHREN: SORGFÄLTIG LESEN

- Muss von einem Erwachsenen zusammengebaut werden. Der Zusammenbau muss vor dem Gebrauch von einem Erwachsenen überprüft werden
- WARNUNG! Bewahren Sie alle Schrauben, Kleinteile und Plastikbeutel außerhalb der Reichweite von Kindern auf
- Kennzeichnen Sie vor dem Zusammenbau alle Teile richtig
- Benutzen Sie Ihren Artikel niemals, wenn Teile gebrochen sind oder fehlen
- Sollten Probleme auftreten, wenden Sie sich bitte an unseren Kundendienst
- Die Anweisungen des Herstellers sind stets zu befolgen
- Pflege: Mit einem weichen, trockenen Tuch reinigen. Bei größeren Flecken vorsichtig mit einem leicht feuchten, nicht scheuernden Schwamm abreiben. nicht scheuernden Schwamm
- Vermeiden Sie die Gefahr eines Brandes, indem Sie die Möbel nicht in der Nähe von Zündquellen oder heißen Gegenständen aufstellen
- Nicht auf das Bett springen

## Français

### IMPORTANT ! CONSERVER POUR RÉFÉRENCE ULTÉRIEURE : LIRE ATTENTIVEMENT

- Le montage doit être effectué par un adulte. Le montage doit être vérifié par un adulte avant Utilisation
- ATTENTION ! Tenir les vis, les petites pièces et les sachets en plastique hors de portée des enfants
- Identifiez correctement toutes les pièces avant de les assembler
- N'utilisez jamais votre article si l'une de ses pièces est cassée ou manquante
- En cas de problème, veuillez contacter notre service après-vente
- Les instructions du fabricant doivent être respectées à tout moment
- Entretien : nettoyer avec un chiffon doux et sec. En cas de taches plus importantes, frotter soigneusement avec une éponge non abrasive légèrement humide. légèrement humide et non Abrasive
- Évitez les risques d'incendie en ne plaçant pas les meubles à proximité de sources d'inflammation ou d'objets chauds
- Ne pas sauter sur le lit

## Italiano

### IMPORTANTE! CONSERVARE PER RIFERIMENTO FUTURO: LEGGERE ATTENTAMENTE

- Deve essere assemblato da un adulto. L'assemblaggio deve essere controllato da un adulto prima dell'uso
- **ATTENZIONE!** Tenere tutte le viti, le piccole parti e i sacchetti di plastica fuori dalla portata dei bambini
- Identificare correttamente tutte le parti prima dell'assemblaggio
- Non utilizzare mai l'articolo se alcune parti sono rotte o mancanti
- In caso di problemi, si prega di contattare il nostro Servizio Post Vendita
- Le istruzioni del produttore devono essere sempre seguite
- Cura: Pulire con un panno morbido e asciutto. In caso di macchie più estese, strofinare accuratamente con una spugna leggermente umida e nonspugna leggermente umida e non abrasiva
- Evitare il rischio di incendio, non collocando i mobili vicino a fonti di accensione o a oggetti caldi
- Non saltare sul letto

## Español

### ¡ IMPORTANTE ! CONSERVELO PARA FUTURAS CONSULTAS: LEA ATENTAMENTE

- Debe ser montado por un adulto. El montaje debe ser comprobado por un adulto antes del uso
- **ADVERTENCIA** Mantenga todos los tornillos, piezas pequeñas y bolsas de plástico fuera del alcance de los niños.
- Identifique correctamente todas las piezas antes de montarlas
- Nunca utilice su artículo si alguna de sus piezas está rota o falta
- Si surge algún problema, póngase en contacto con nuestro Servicio Postventa
- Las instrucciones del fabricante deben seguirse en todo momento
- Cuidado: Limpiar con un paño suave y seco. En caso de manchas más grandes, frote cuidadosamente con una esponja no abrasiva ligeramente humedecida.
- Evite el riesgo de incendio no colocando los muebles cerca de fuentes de ignición u objetos calientes.
- No saltar sobre la cama.

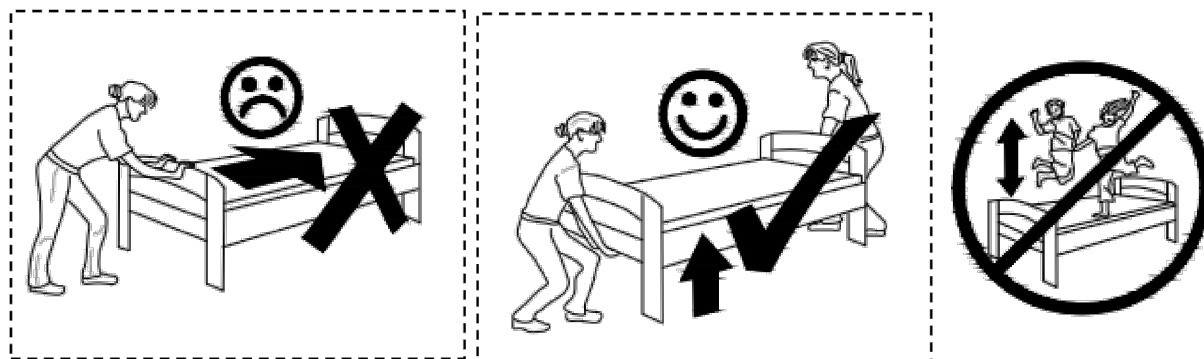

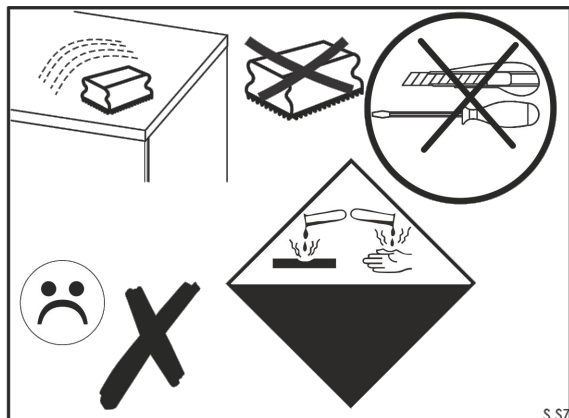
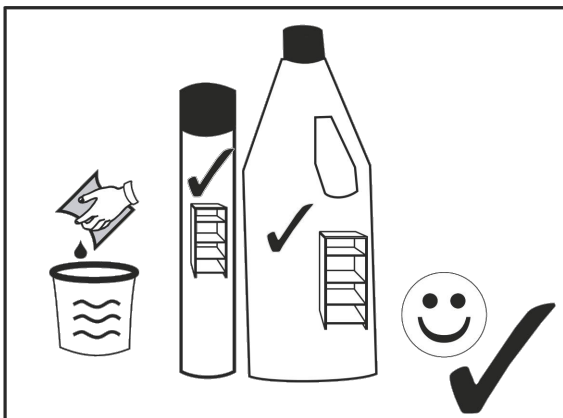
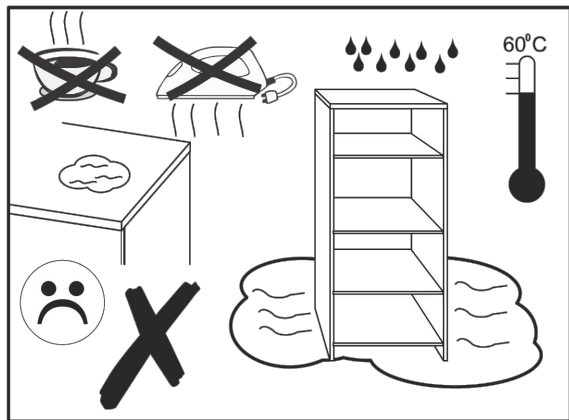
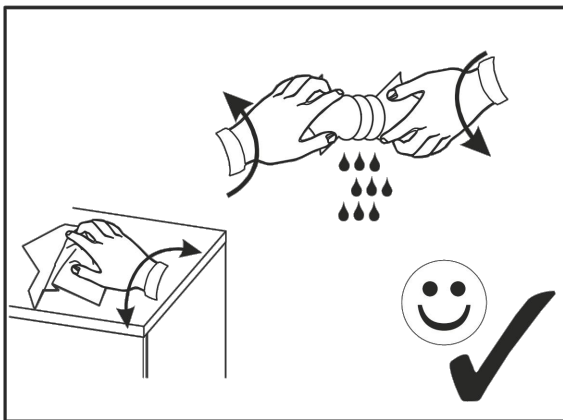
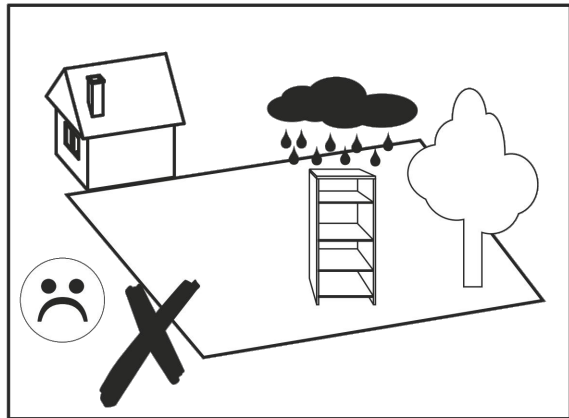
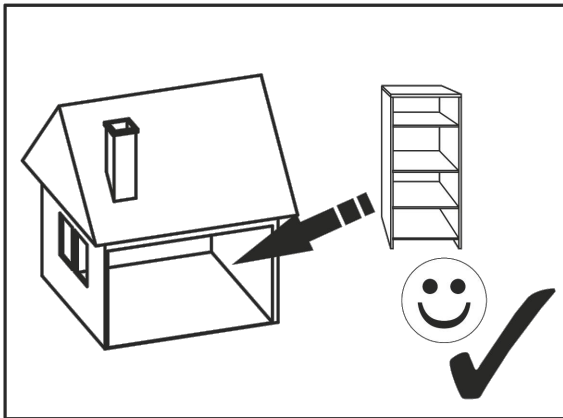

**EN** It may be necessary to adjust the hinges so that the doors align. Use the instructions below as a guide.

**FR** Il est parfois nécessaire d'ajuster les charnières pour un meilleur alignement des portes. Servez-vous des instructions ci-dessous comme guide.

**ES** Puede que sea necesario ajustar los quicios de forma que se alineen las puertas. Use las instrucciones que aparecen debajo como guía.

**DE** Möglicherweise müssen Sie die Scharniere so einstellen, dass die Türen ausgerichtet sind. Verwenden Sie die nachstehenden Anweisungen als Leitfaden.

**IT** Potrebbe essere necessario regolare le cerniere in modo che le porte siano allineate. Per fare ciò attenersi alle istruzioni sottostanti.

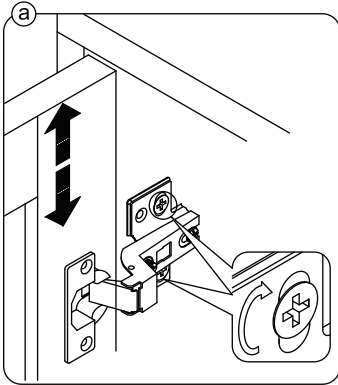

**EN** To adjust the door vertically loosen the screw as shown and move up and down as needed.

**FR** Si vous souhaitez régler la porte **verticalement**, desserrez la vis comme indiqué et déplacez la porte de haut en bas selon les besoins.

**ES** Para ajustar la puerta **verticalmente** afloje el tornillo tal y como se muestra y muévalo hacia arriba o hacia abajo según sea necesario.

**DE** Um die Tür **vertikal** auszurichten, lösen Sie die Schraube wie abgebildet und bewegen Sie sie nach Bedarf nach oben oder nach unten.

**IT** Per allineare la porta **verticalmente** allentare la vite come mostrato e spostarla in alto o in basso secondo necessità.

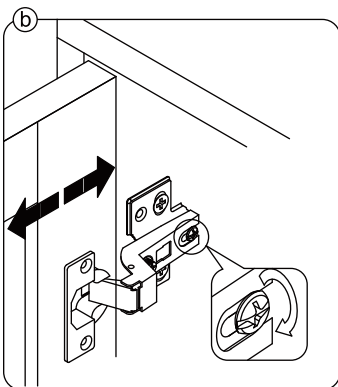

**EN** To adjust the gap from the door to the main frame turn the screw clockwise or anti-clockwise as needed.

**FR** Si vous souhaitez ajuster l'**écart** entre la porte et le cadre principal, tournez la vis dans le sens des aiguilles d'une montre ou dans le sens inverse, si nécessaire.

**ES** Para ajustar el **espacio** desde la puerta al marco principal, gire el tornillo en sentido horario o antihorario, según se necesite.

**DE** Um den **Abstand** von der Tür zum Hauptrahmen auszurichten, drehen Sie die Schraube je nach Bedarf im oder gegen den Uhrzeigersinn.

**IT** Per regolare lo **spazio** tra la porta e il telaio principale, avvitare o svitare la vite secondo necessità.

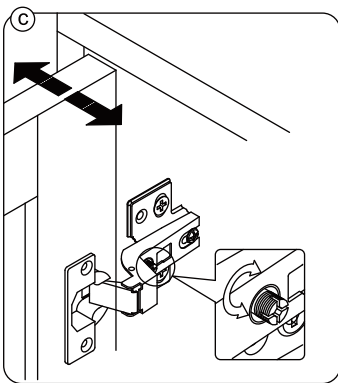

**EN** To adjust the door laterally adjust the screw as shown by turning clockwise or anti-clockwise.

**FR** Si vous souhaitez ajuster la porte **latéralement**, ajustez la vis comme indiqué en tournant dans le sens des aiguilles d'une montre ou dans le sens inverse des aiguilles d'une montre.

**ES** Para ajustar la puerta **lateralmente** ajuste el tornillo tal y como se muestra girándolo en sentido horario y antihorario.

**DE** Um die Tür **seitlich** auszurichten, stellen Sie bitte die Schraube wie abgebildet durch Drehen im oder gegen den Uhrzeigersinn ein.

**IT** Per allineare la porta **lateralmente** regolare la vite come mostrato, avvitandola o svitandola.

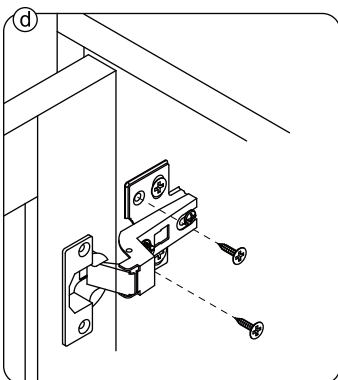

**EN** Please fix other screws

**FR** Merci de serrer les autres vis.

**ES** Fije los demás tornillos

**DE** Befestigen Sie bitte die anderen Schrauben

**IT** Fissare le altre viti

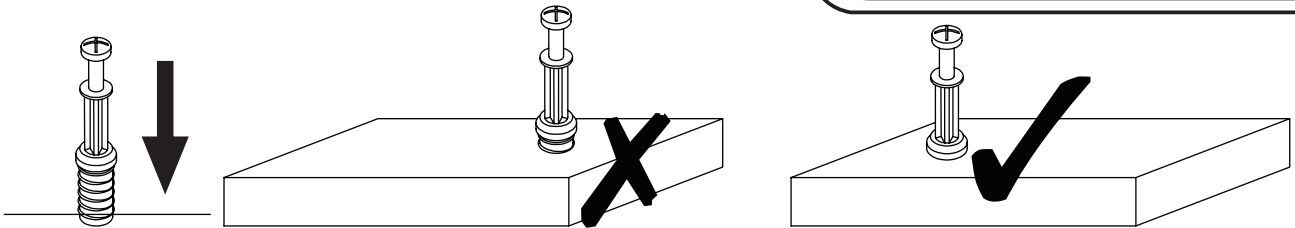

**EN\_QUICKFIT:** Tighten quickfit until shoulder is flush with panel. Do not overtighten or undertighten.

**FR\_RACCORD RAPIDE:** Faites serrer le raccord rapide jusqu'à ce que l'épaulement soit parfaitement encastré dans le panneau. Il ne faut ni trop serrer ni insuffisamment serrer.

**ES\_QUICKFIT:** Apriete quickfit hasta que el hombro se descargue con el panel. NO lo sobreapriete ni lo apriete poco.

**DE\_QUICKFIT:** Ziehen Sie den Quickfit fest, bis die Schulter mit der Platte bündig ist. Bitte nicht zu fest oder zu schwach anziehen.

**IT\_MONTAGGIO RAPIDO:** Stringere il montaggio rapido fino a quando la spalla è a filo con il pannello, non stringere troppo o troppo poco.

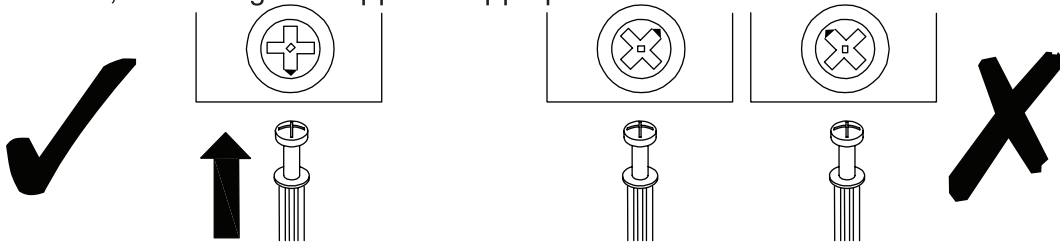

**EN\_CAM LOCK:** When fitting cam lock, ensure starting position is correct before you insert connecting quickfit.

**FR\_SERRURE BATTEUSE:** Avant d'insérer la serrure batteuse, veillez à la bonne orientation avant d'insérer le raccord rapide.

**ES\_CIERRE DE LA CÁMARA:** Cuando instale el cierre de la cámara, asegúrese de que la posición de inicio es correcta antes de que inserte el quickfit conector.

**DE\_CAM-LOCK:** Achten Sie bei der Montage des Cam-Locks auf die richtige Ausgangsposition, bevor Sie den Quickfit einsetzen.

**IT\_BLOCCAGGIO A CAMMA:** Quando si monta il bloccaggio a camma, assicurarsi che la posizione iniziale sia corretta prima di inserire il montaggio rapido di collegamento.

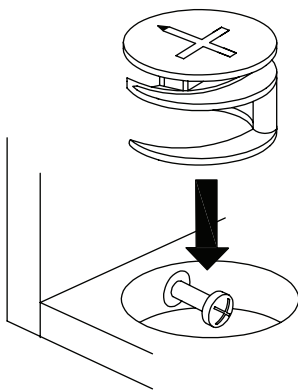

**EN\_Quickfit head** should be in the centre of the cam lock when the two panels are joined.

Cam lock should be inserted before quickfit.

**FR\_Lorsque** les deux panneaux sont assemblés, la tête du raccord rapide doit reposer au centre de la serrure batteuse. Il faut insérer la serrure batteuse avant le raccord rapide.

**ES\_El** cabezal del quickfit debe estar en el centro del cierre de la cámara cuando se unan los dos paneles.

Se debe insertar el cierre de la cámara antes que el quickfit.

**DE\_Der** Quickfit-Kopf sollte sich in der Mitte des Cam-Locks befinden, wenn die beiden Platten zusammengefügt sind.

Der Cam-Lock sollte vor dem Quickfit eingesetzt werden.

**IT\_La** testa del montaggio rapido deve trovarsi al centro del bloccaggio a camma quando i due pannelli sono uniti.

Il Bloccaggio a Camma deve essere inserito prima del montaggio rapido.

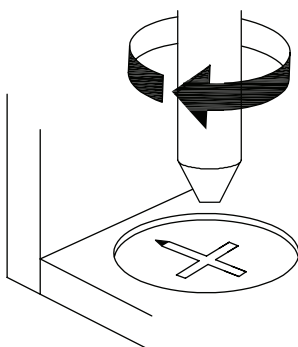

**EN\_Turn** cam lock clockwise to tighten.

**FR\_Faites** tourner la serrure batteuse dans le sens des aiguilles d'une montre pour la resserrer.

**ES\_Gire** el cierre de la cámara en sentido horario para apretarlo.

**DE\_Drehen** Sie den Cam-Lock im Uhrzeigersinn, um ihn festzuziehen.

**IT\_Ruotare** il bloccaggio a camma in senso orario per stringere.

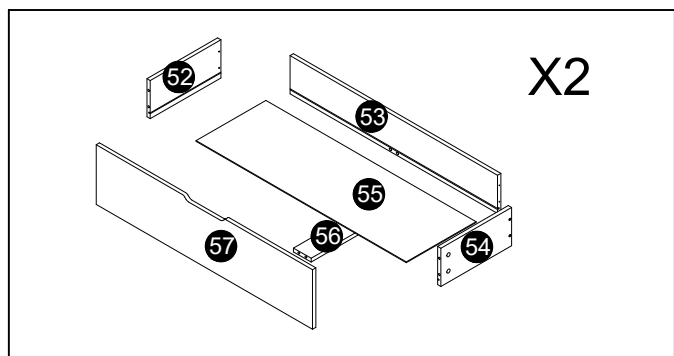
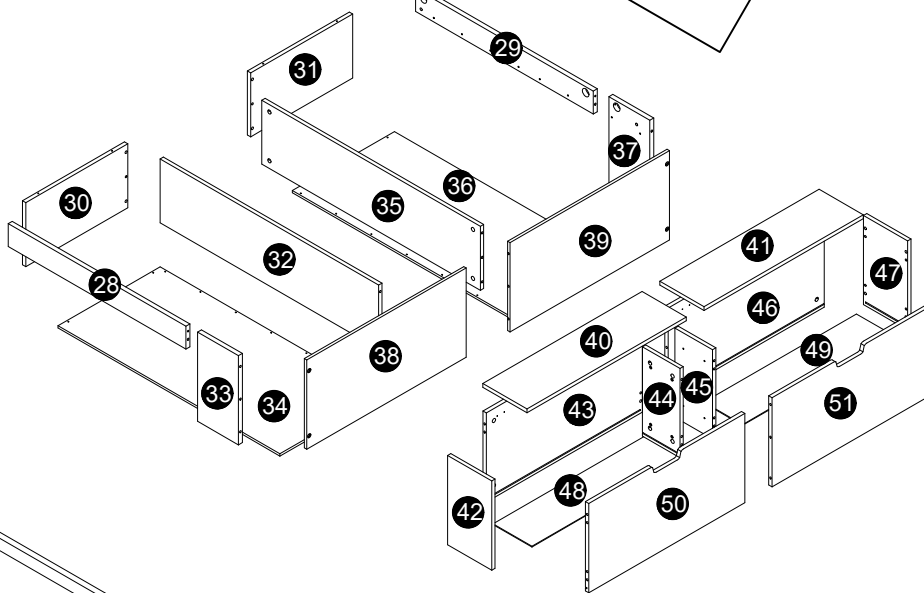
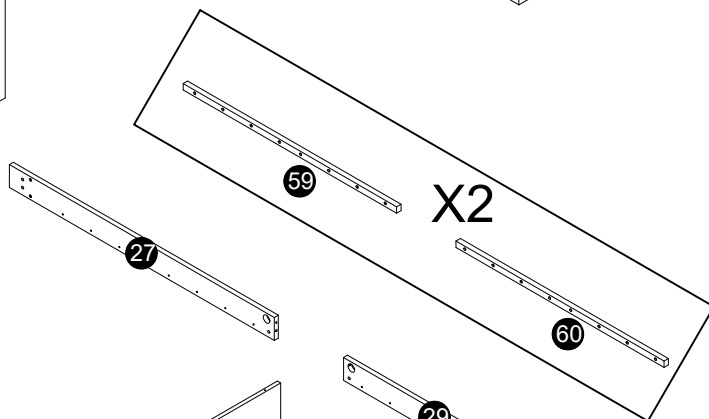
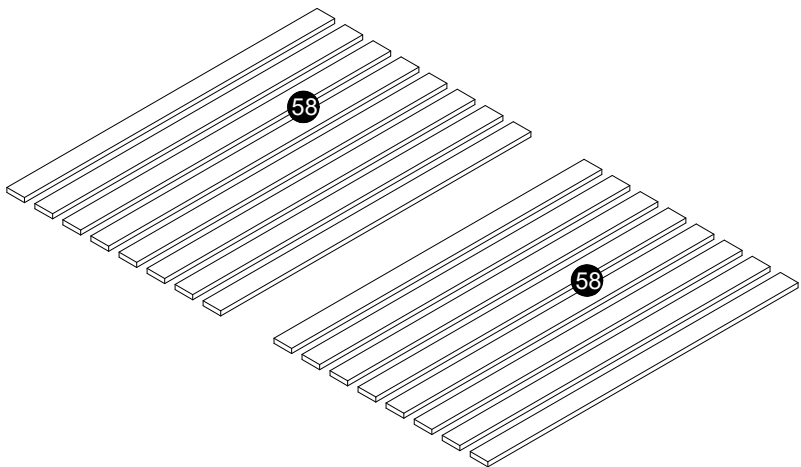
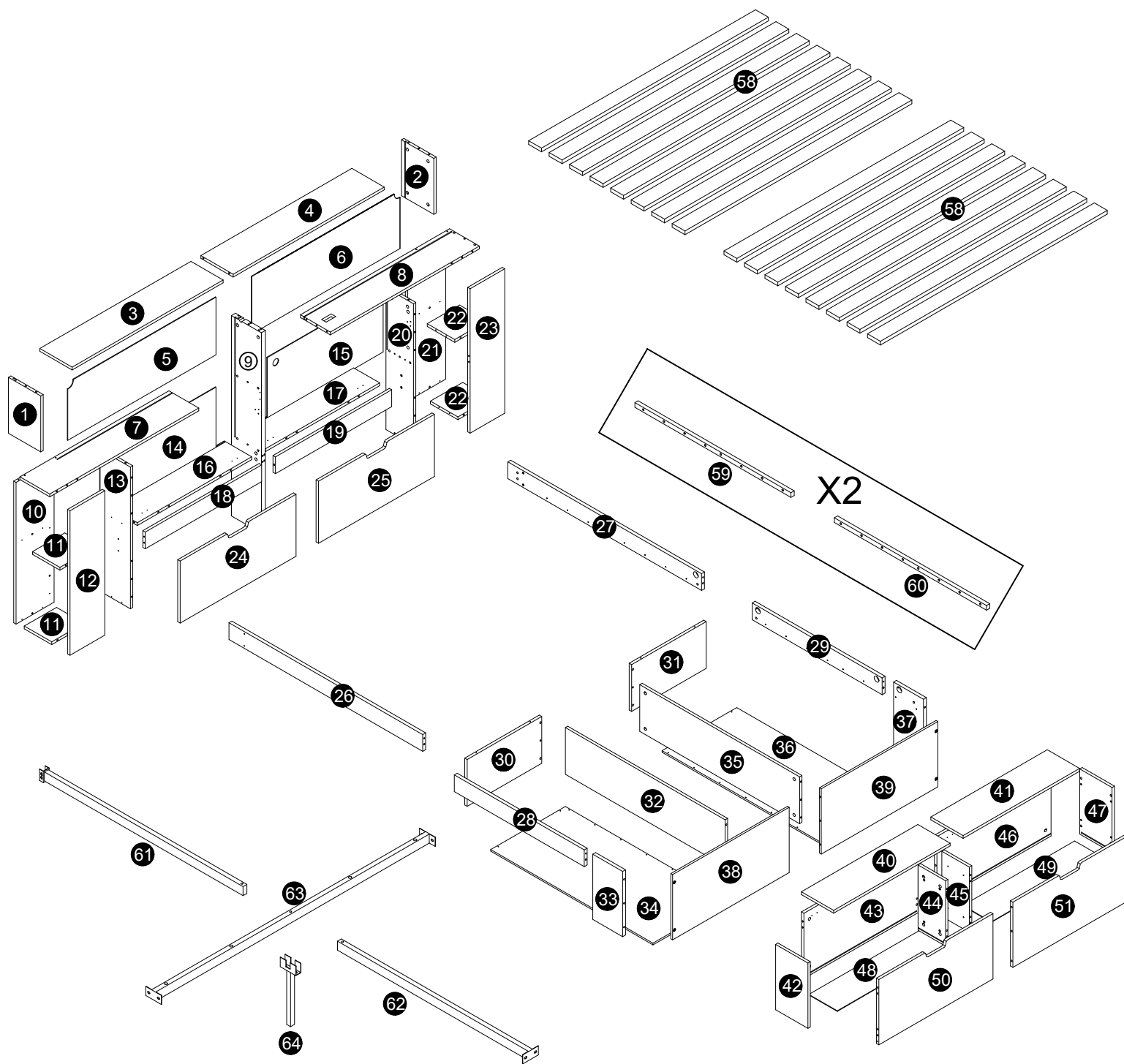

# GETTING TO KNOW YOUR PRODUCT

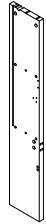
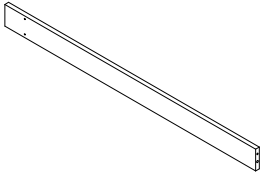
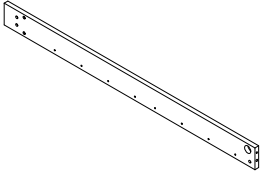
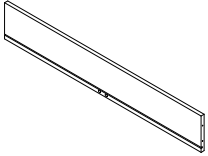
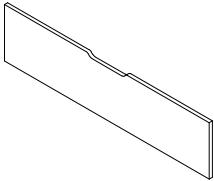
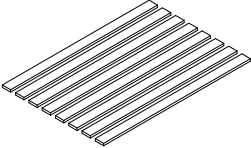

# Part List/Teileliste/Liste des pieces

## N616P373598W

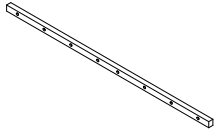
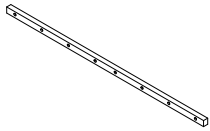
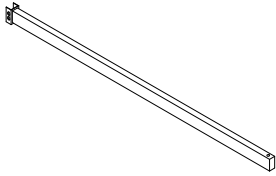
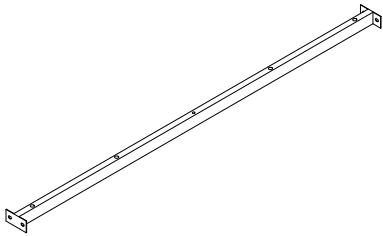
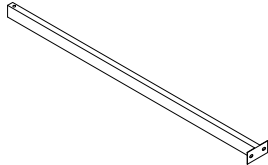

9		*1
26		*1
27		*1
53		*2
57		*2
58		*2

59		*2
60		*2
61		*1
62		*1
63		*1
64		*1

# Part List/Teileliste/Liste des pieces

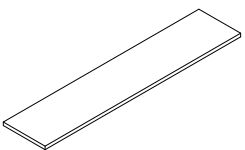
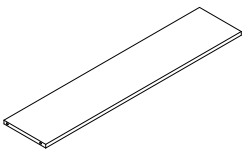
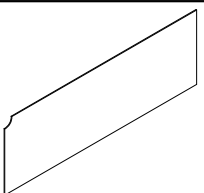
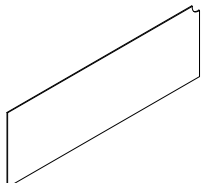
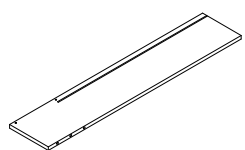
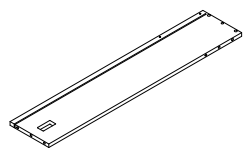
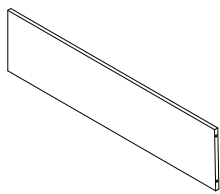
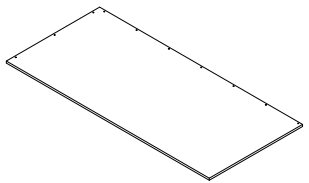
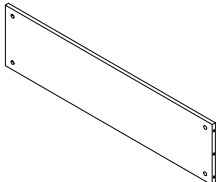
## N616P373599W

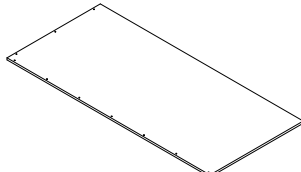
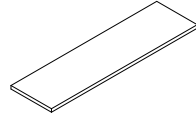
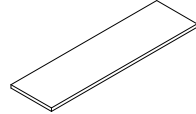
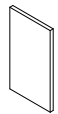

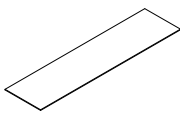
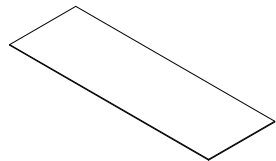
3		*1
4		*1
5		*1
6		*1
7		*1
8		*1
32		*1
34		*1
35		*1

36		*1
40		*1
41		*1
42		*1
47		*1
48		*1
49		*1
55		*2

# Part List/Teileliste/Liste des pieces

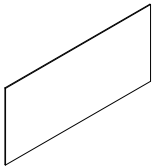
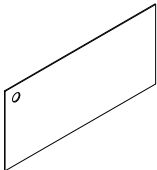
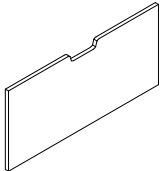
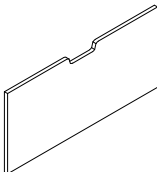
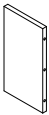
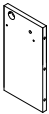
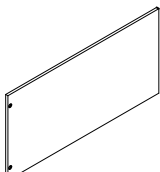
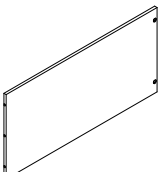
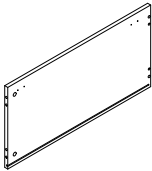

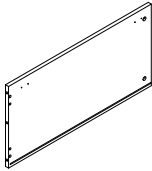
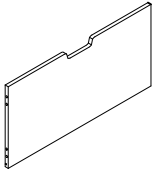
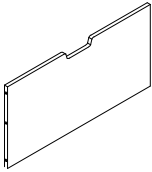

## N616P373600W



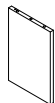
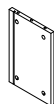

14		*1
15		*1
24		*1
25		*1
33		*1
37		*1
38		*1
39		*1
43		*1

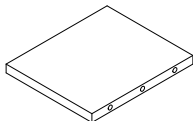
44		*1
45		*1
46		*1
50		*1
51		*1

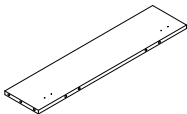
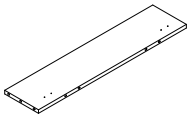
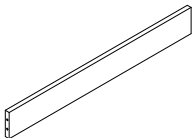
# Part List/Teileliste/Liste des pieces

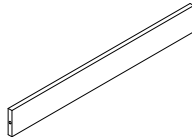

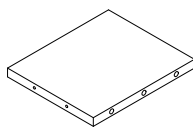
## N616P373601W

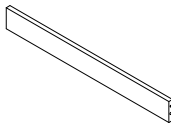
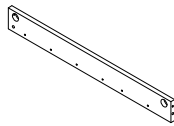
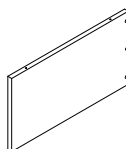
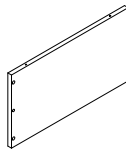
1		*1
2		*1
10		*1
11		*2
12		*1
13		*1
16		*1
17		*1
18		*1

19		*1
20		*1
21		*1
22		*2
23		*1
28		*1
29		*1
30		*1
31		*1





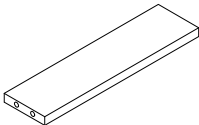
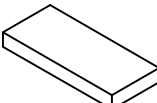



















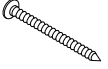

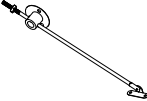
# Part List/Teileliste/Liste des pieces

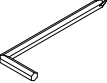
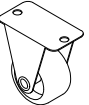
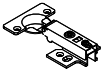
## N616P373601W

52		*2
54		*2
56		*2
 Hardware kit		

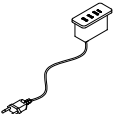
# Hardware List/ Hardware-Liste/Liste du matériel

## N616P373601W

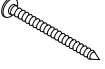
 40mm	 15*9mm	 8*40mm	 6*20mm	 6*14mm
<b>A*96+2</b>	<b>B*100+2</b>	<b>C*68+1</b>	<b>D*8</b>	<b>E*8</b>
 M6	 6*90mm	 6*80mm	 6*60mm	 M6
<b>F*12</b>	<b>G*8</b>	<b>H*4</b>	<b>I*4</b>	<b>J*10</b>
	 5*40mm	 3.5*25mm	 3.5*14mm	
<b>k*8</b>	<b>L*26+2</b>	<b>N*20+2</b>	<b>O*130+2</b>	<b>U*24</b>
 4*30mm			 R1  R2	
<b>P*72+2</b>	<b>M*4</b>	<b>Q*4</b>	<b>R*2</b>	<b>V*2</b>
			 6*12mm	
<b>W*8</b>	<b>X*4</b>	<b>T*2</b>	<b>S*10</b>	<b>JJ*2</b>
 6*70mm				
<b>AA*3</b>	<b>BB*1</b>	<b>CC*1</b>	<b>DD*100+2</b>	<b>EE*8</b>
	 4*50mm			
<b>FF*4</b>	<b>GG*4</b>			

1

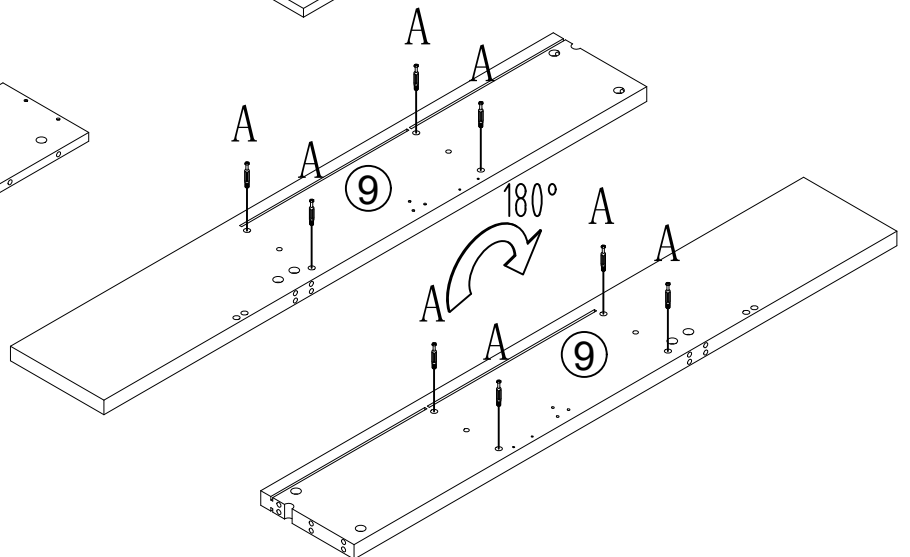
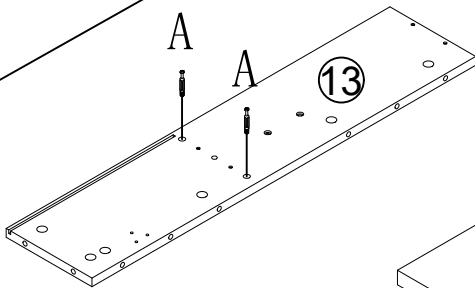
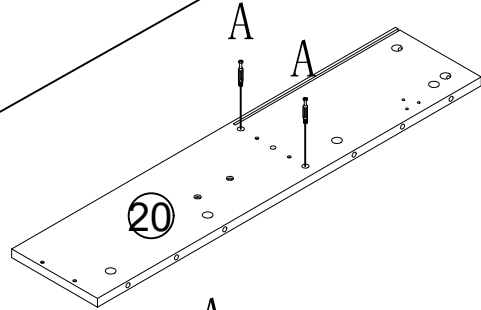
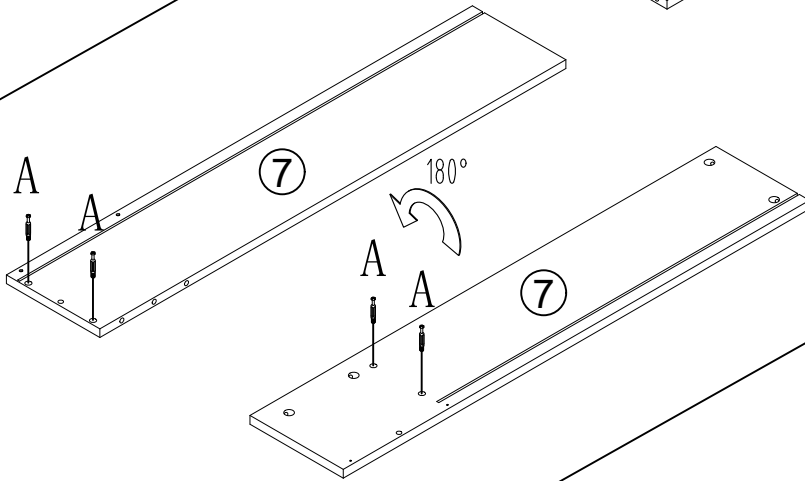
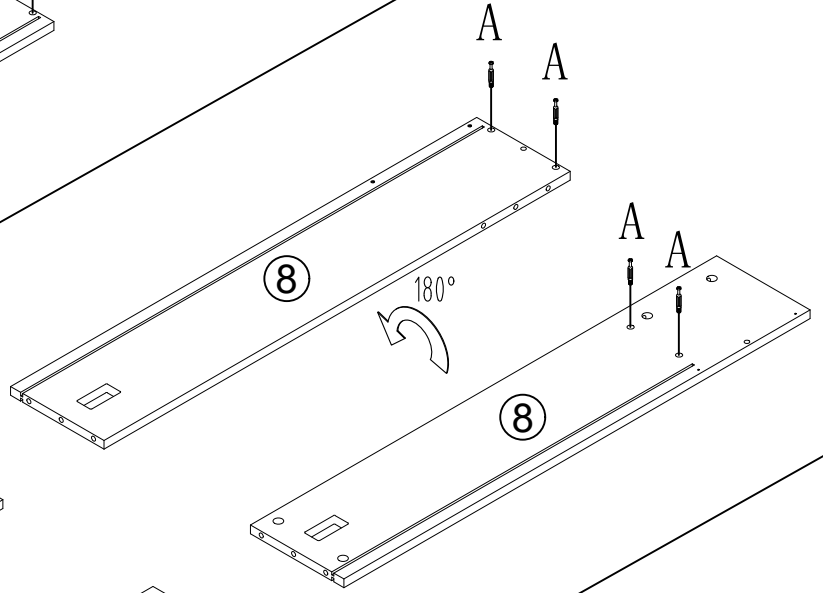
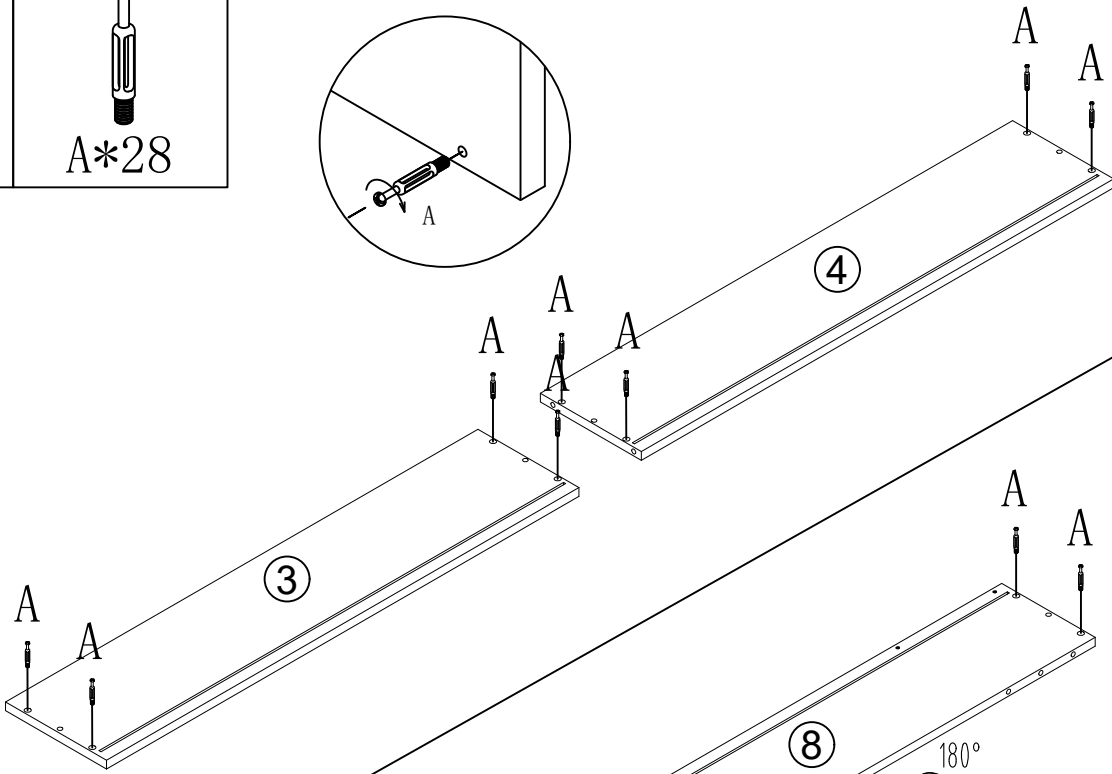
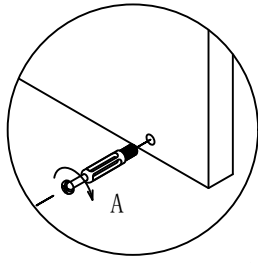

2



A\*36

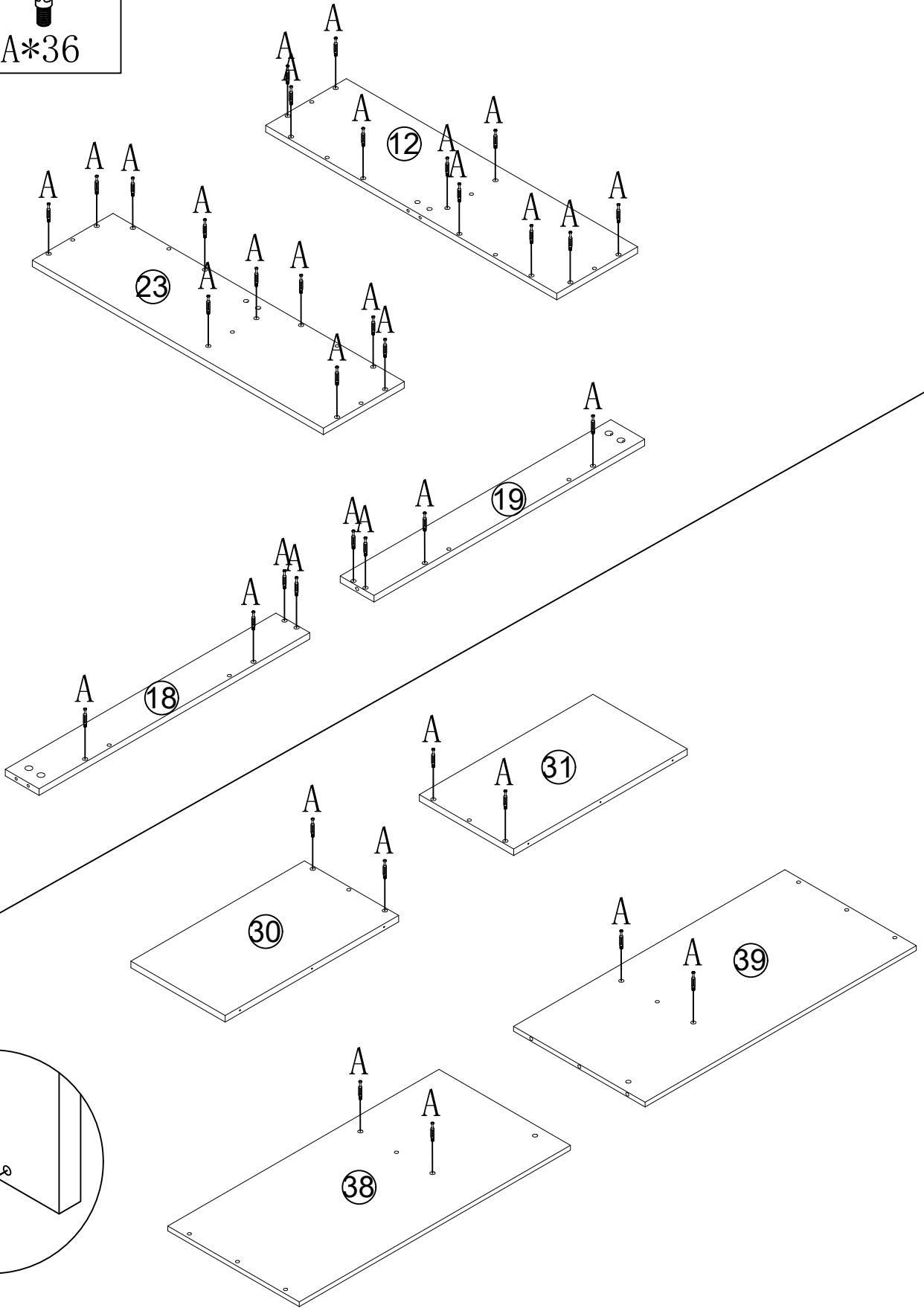

3



A\*32

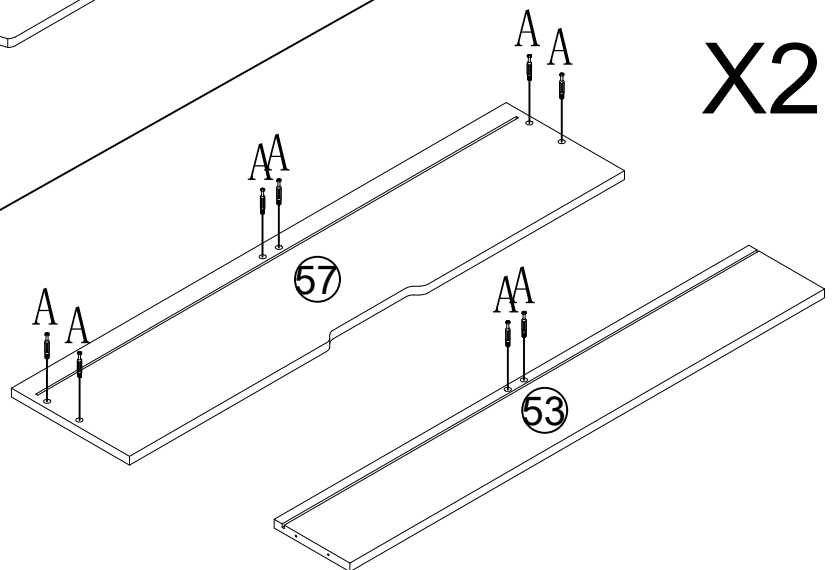
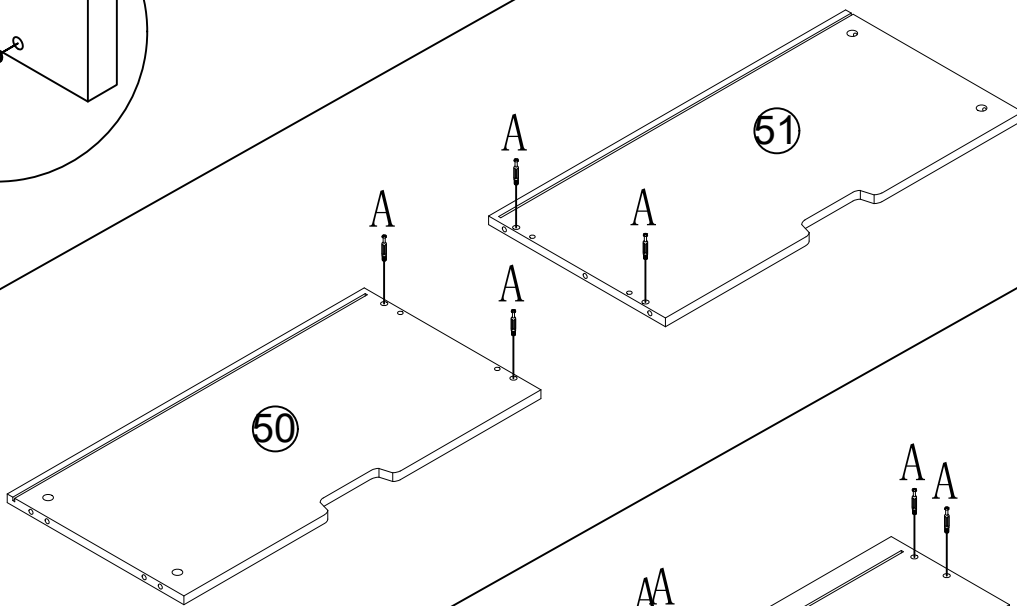
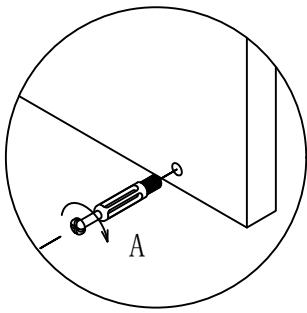
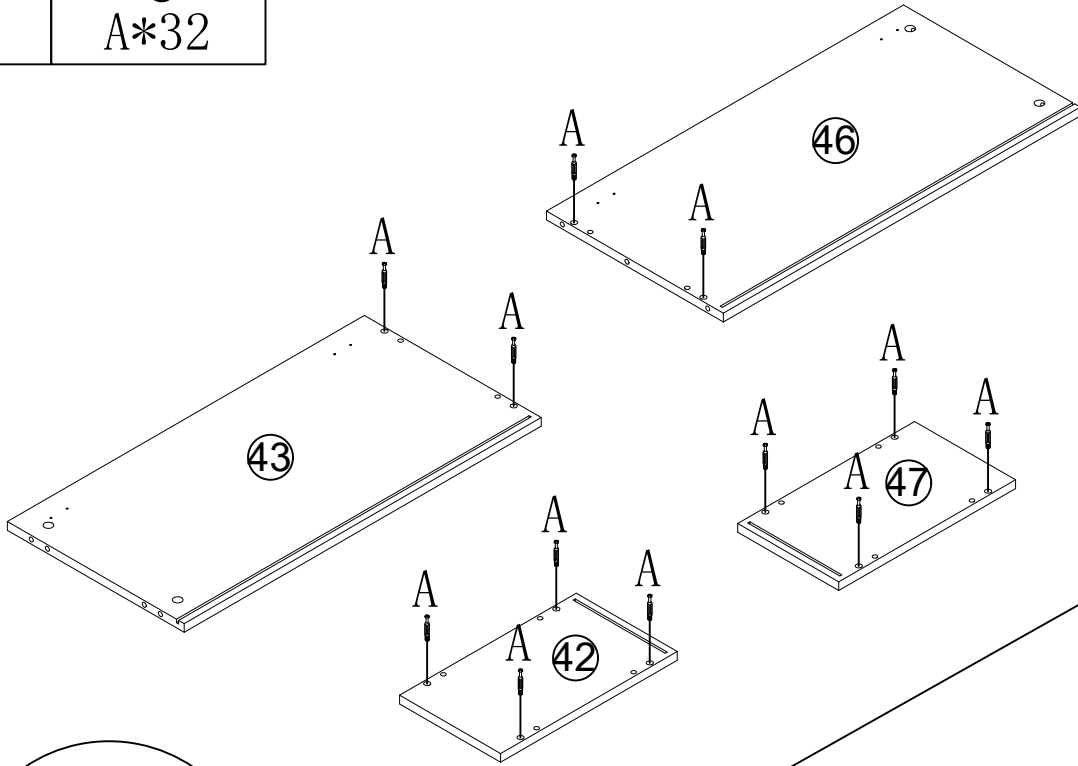

4

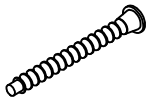

L\*4

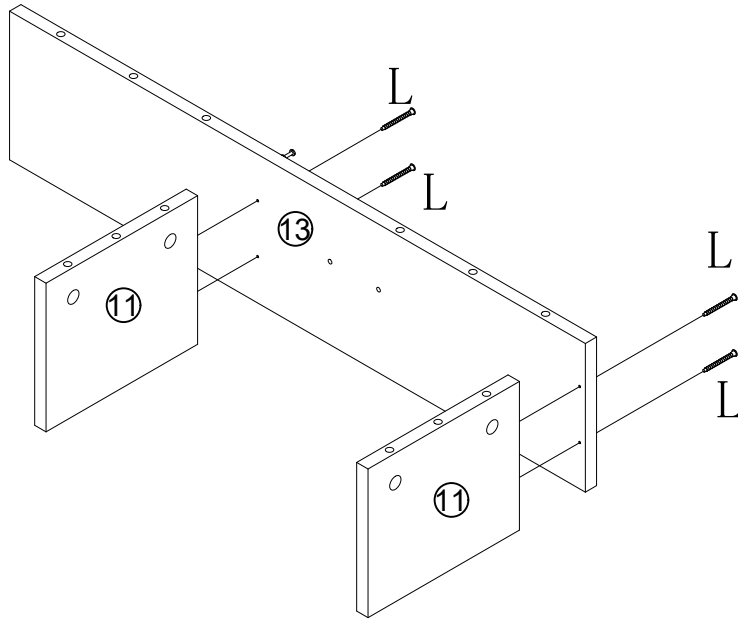

5



C\*3



L\*7

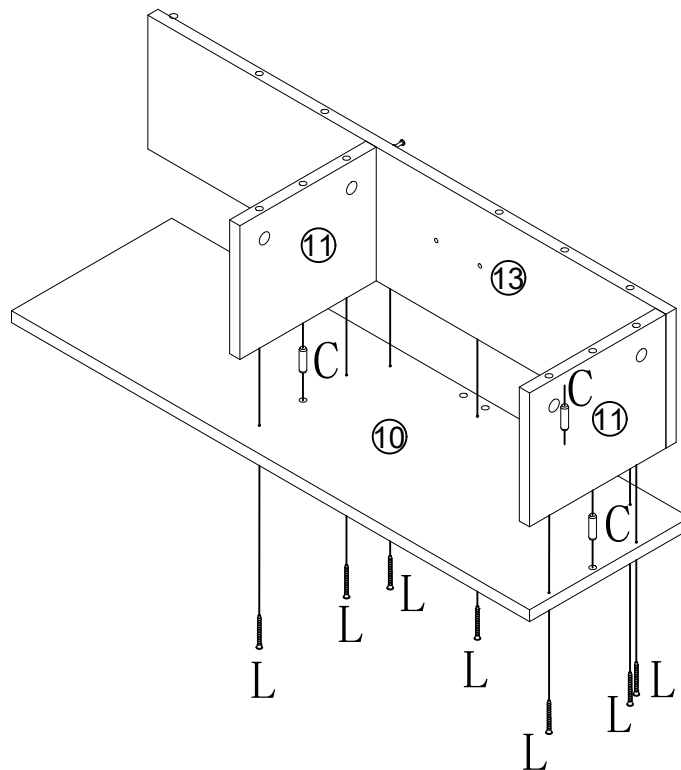

# 6



B\*2

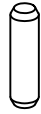

C\*1



L\*2

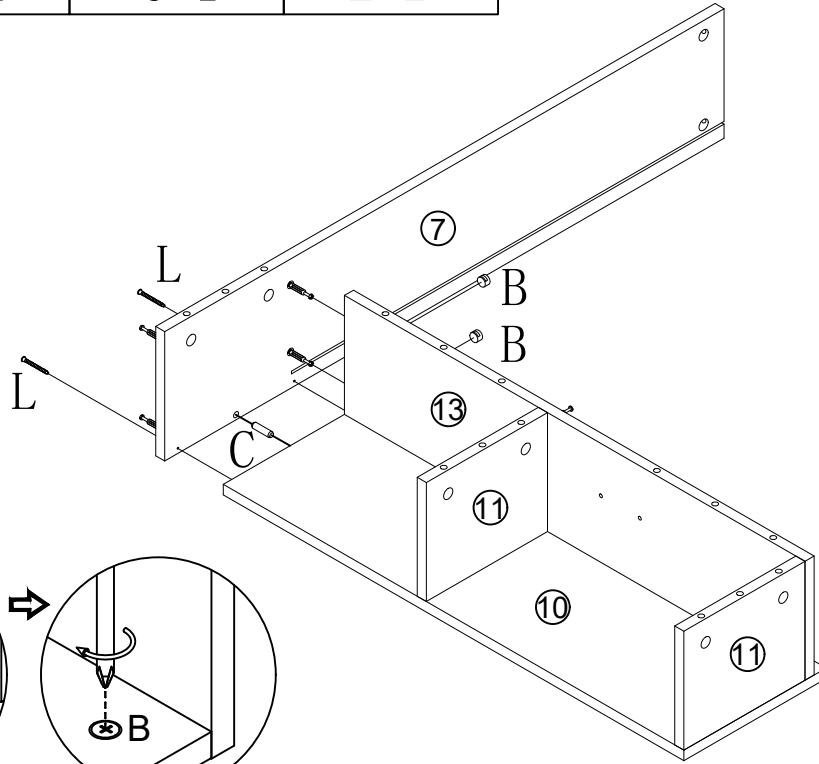

# 7



B\*2

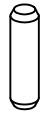

C\*1

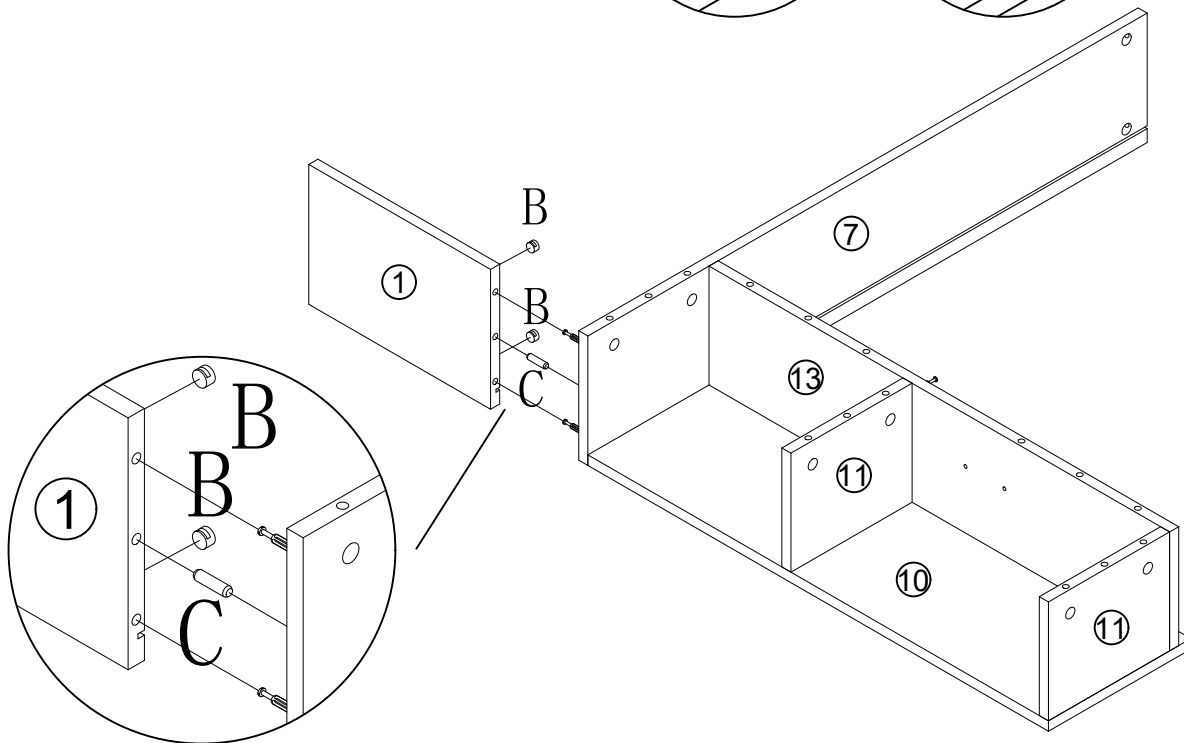
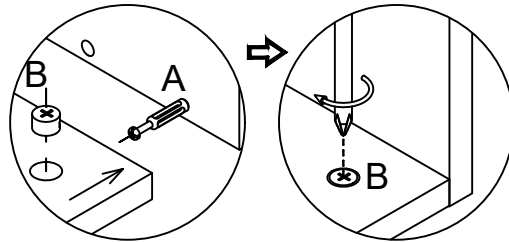

8

  
B\*2

  
C\*1

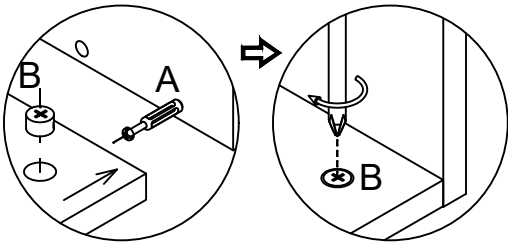
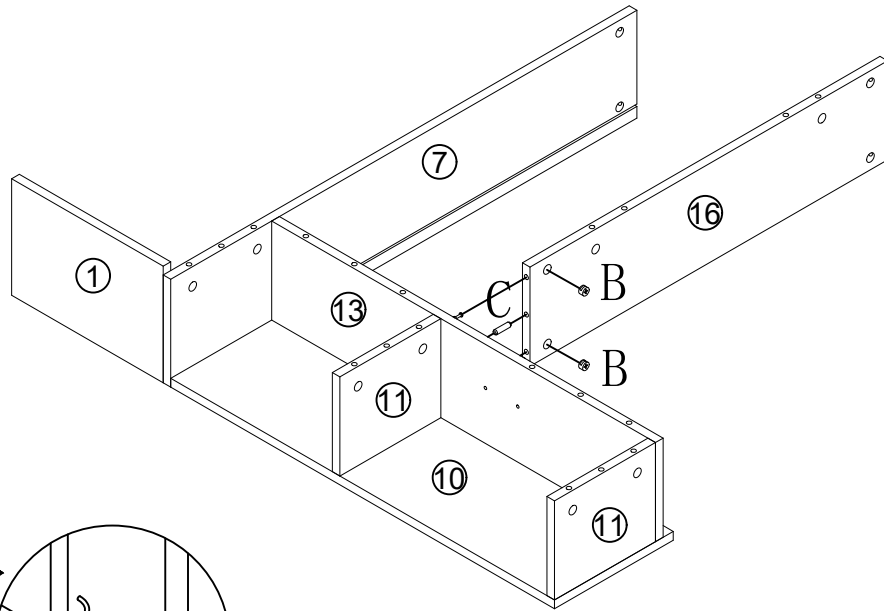

9

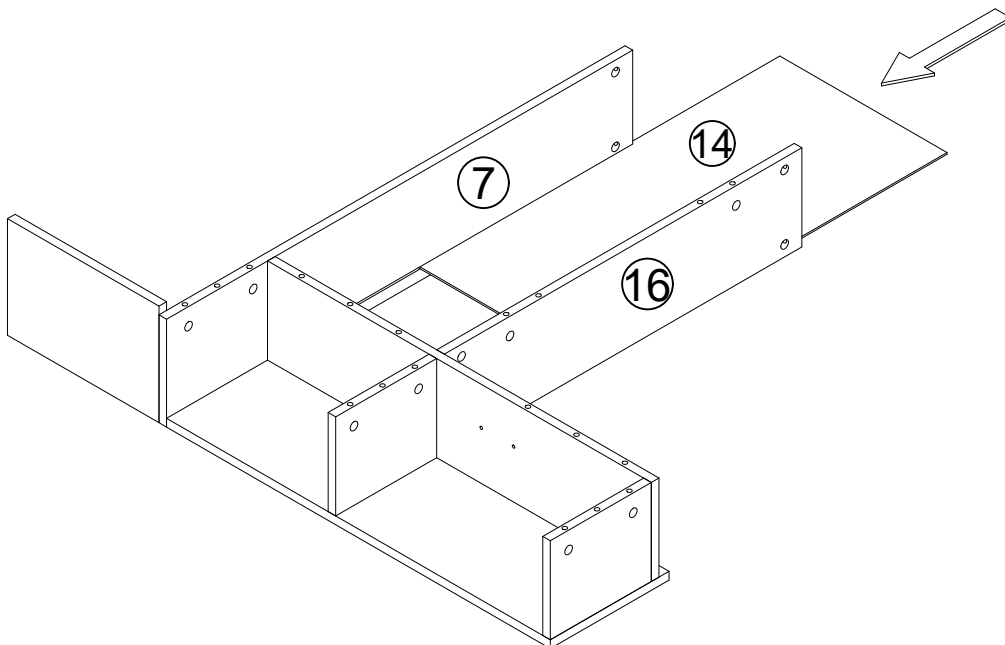

# 10



B\*4

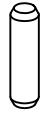

C\*2

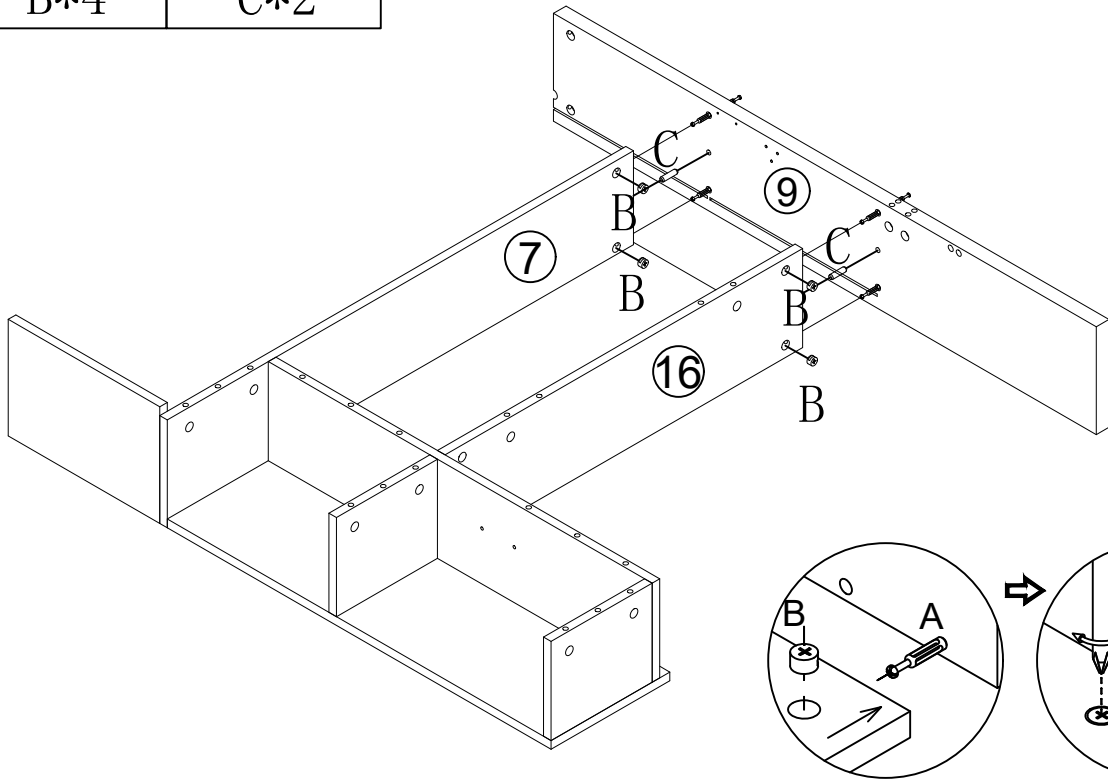

# 11

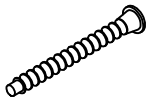

L\*4

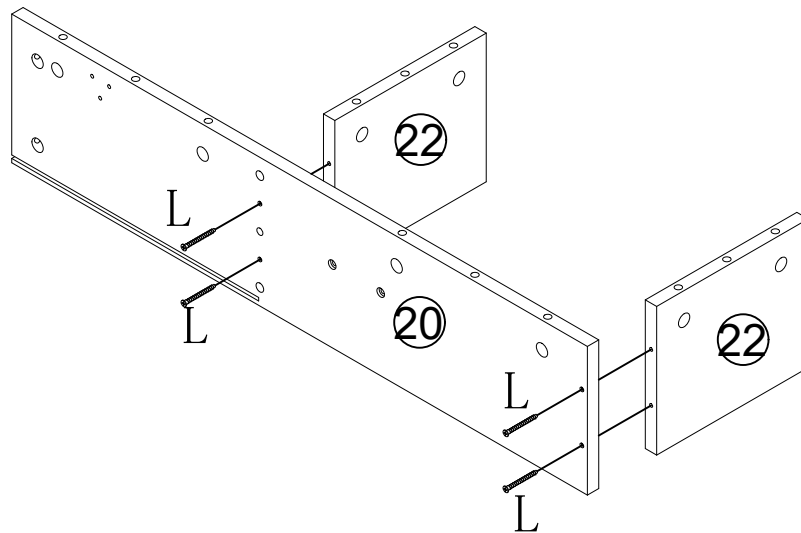

# 12

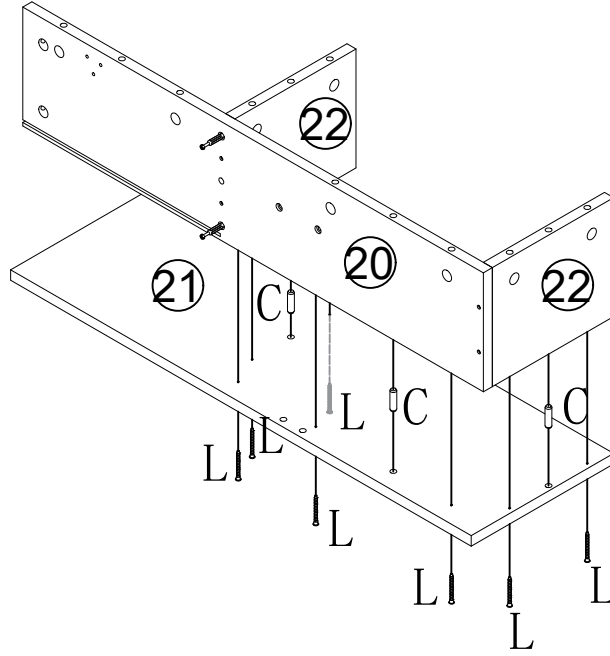

# 13

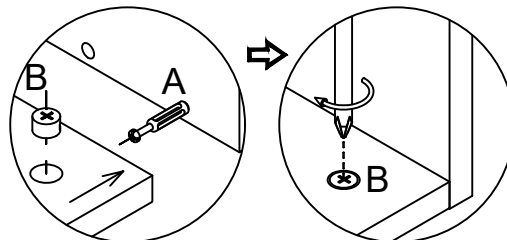
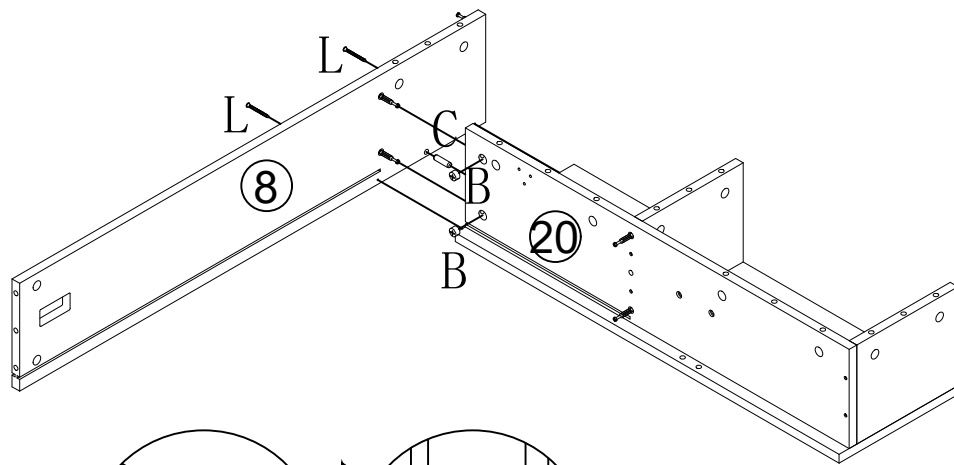
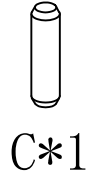

# 14



B\*2

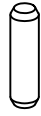

C\*1

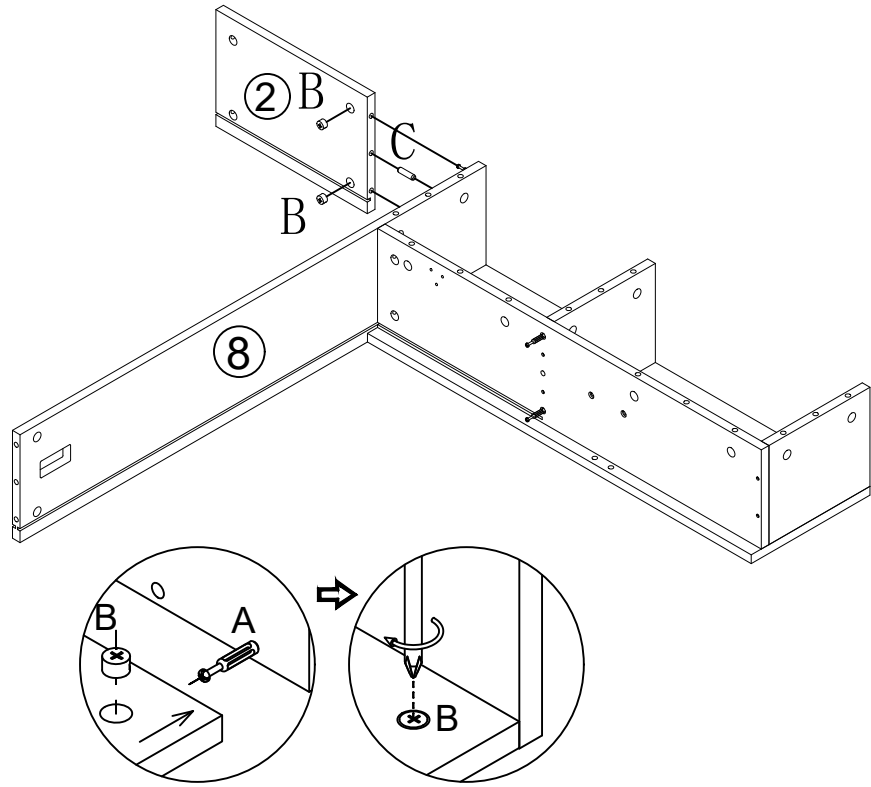

# 15



B\*2

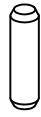

C\*1

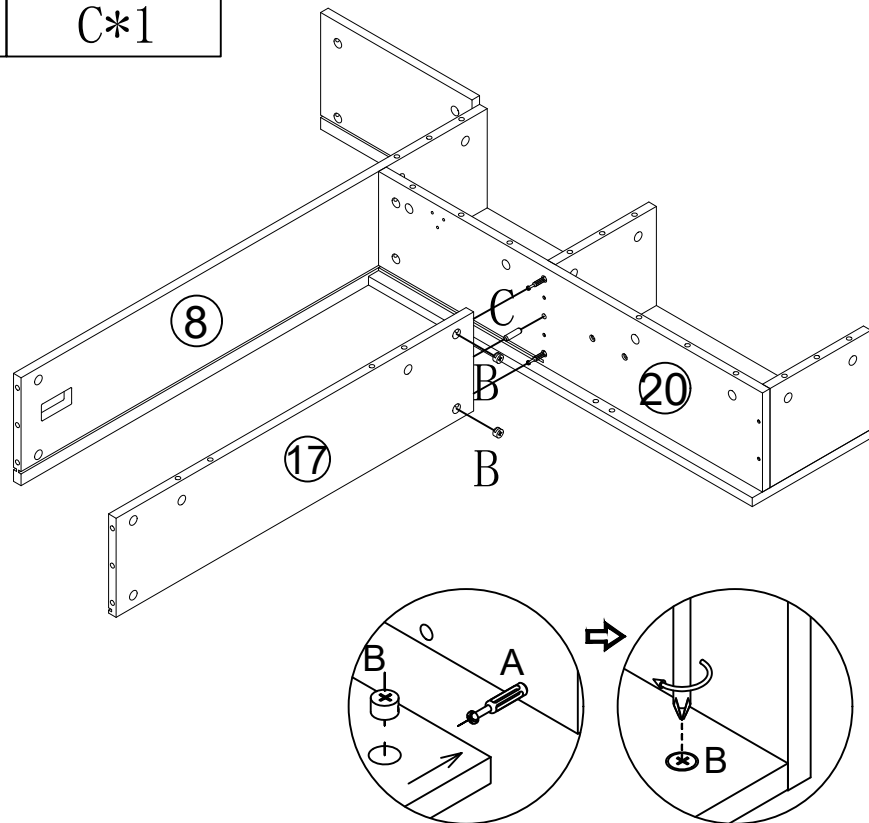

# 16

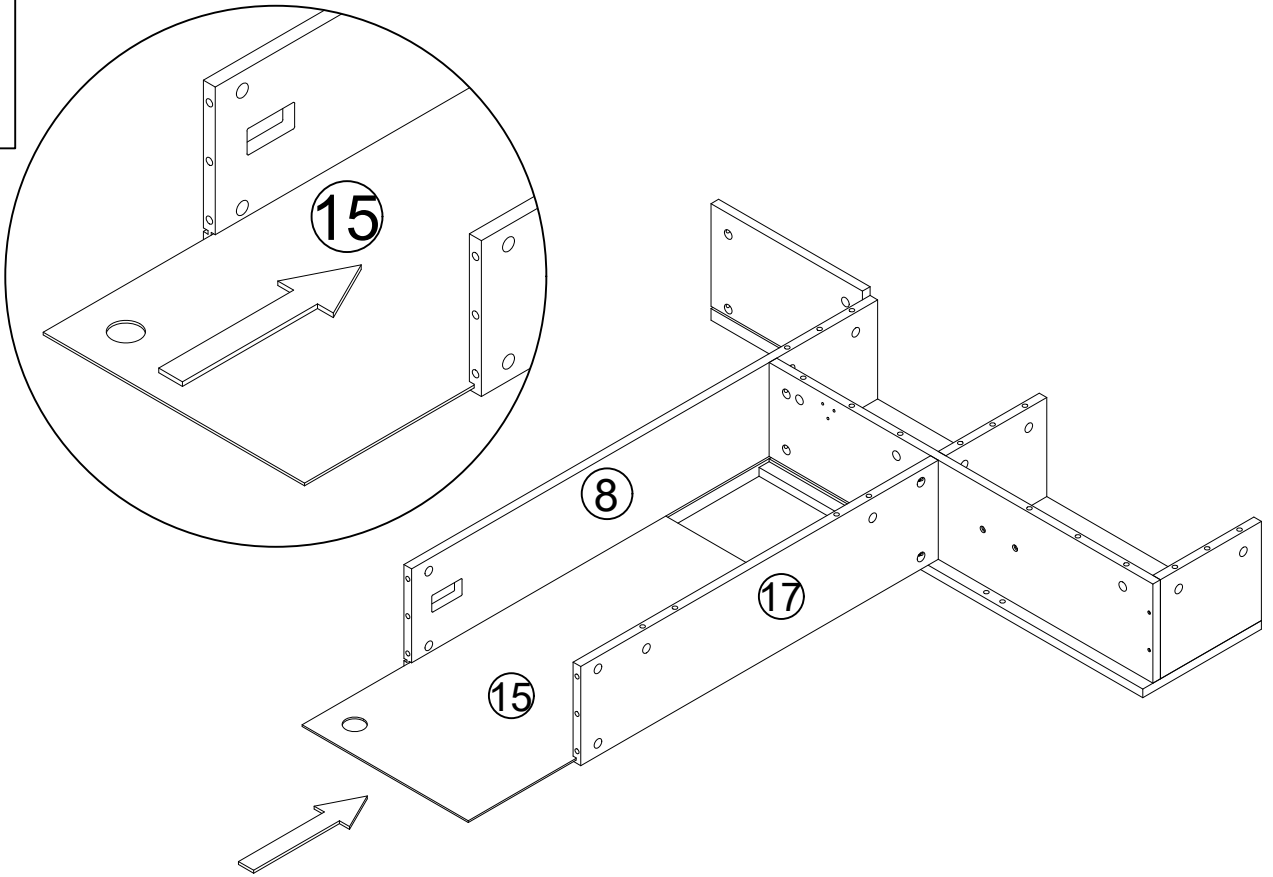

# 17



B\*4

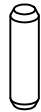

C\*2

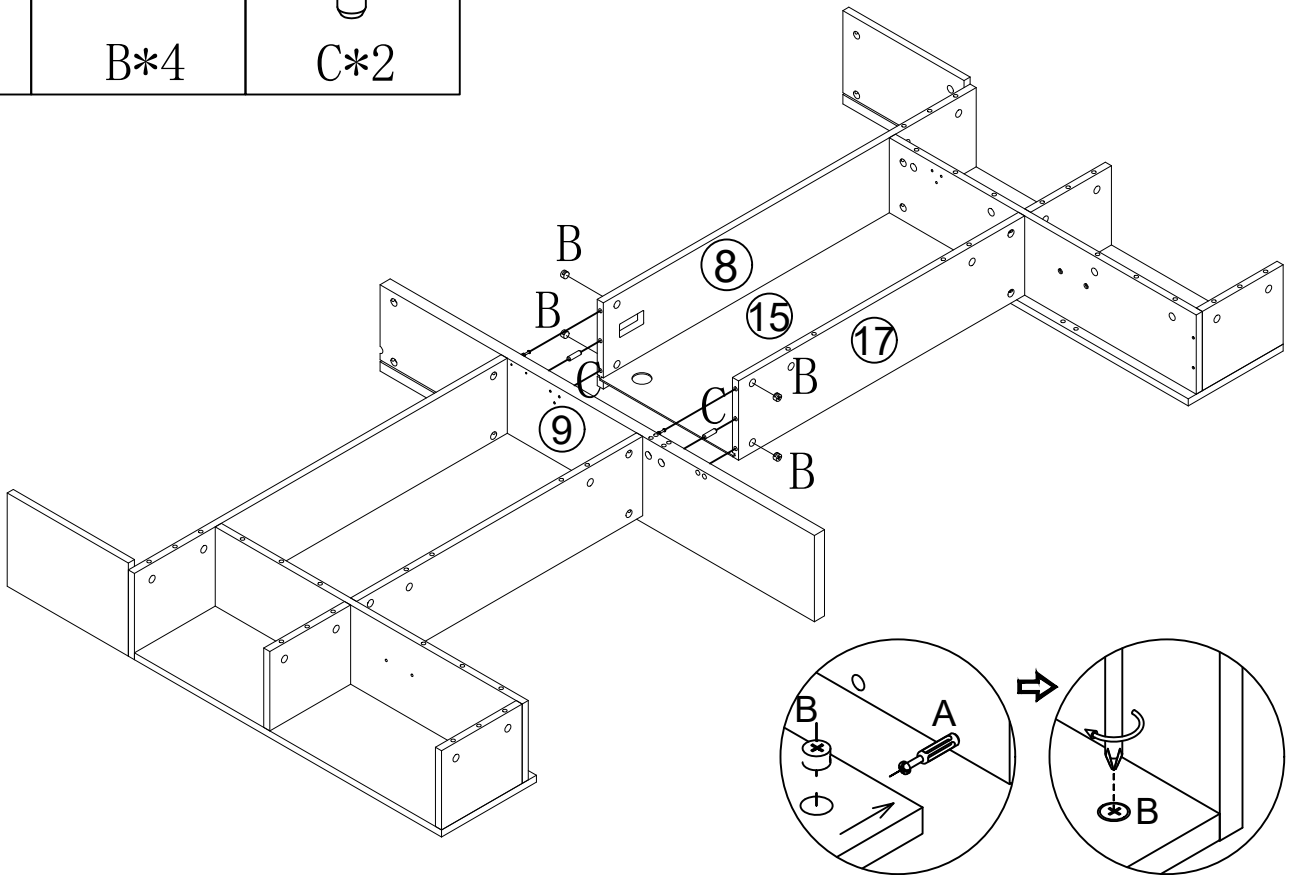

# 18

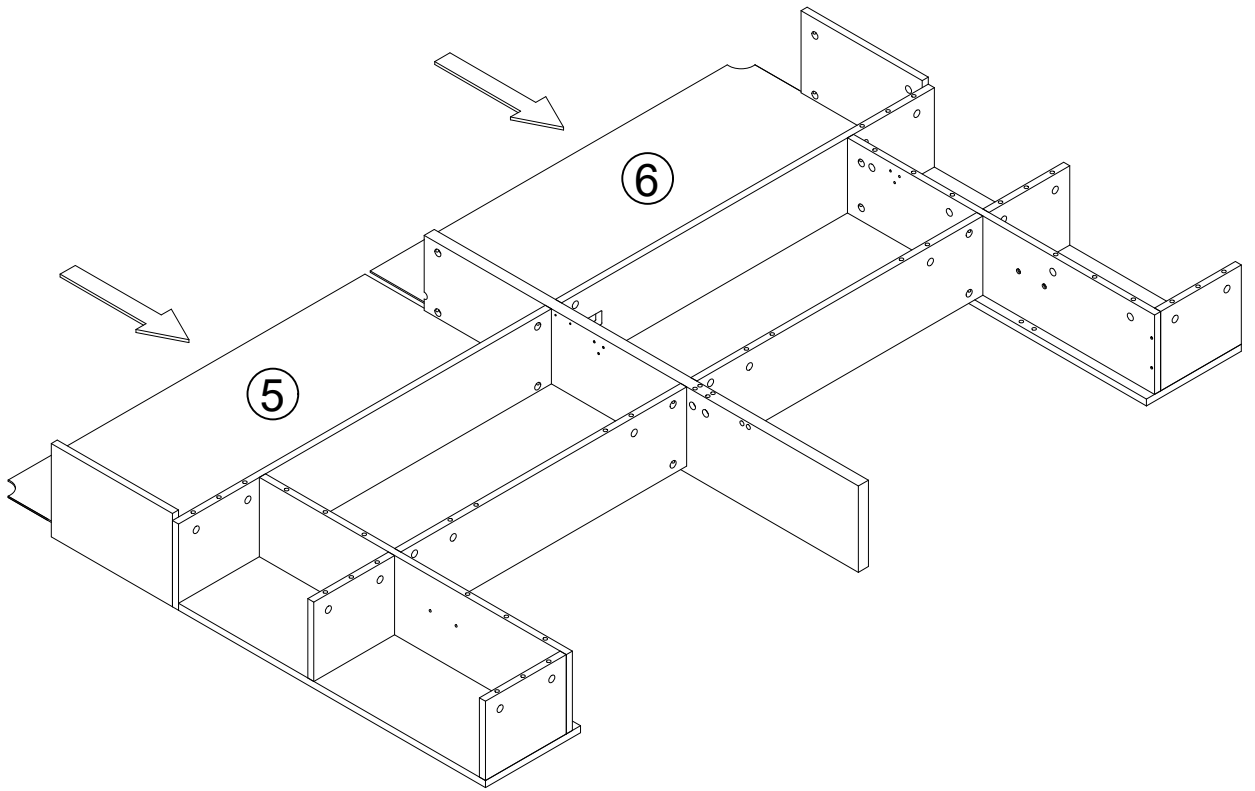

# 19



B\*8



C\*6

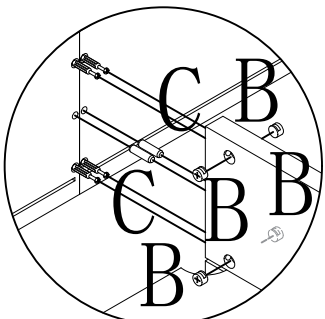
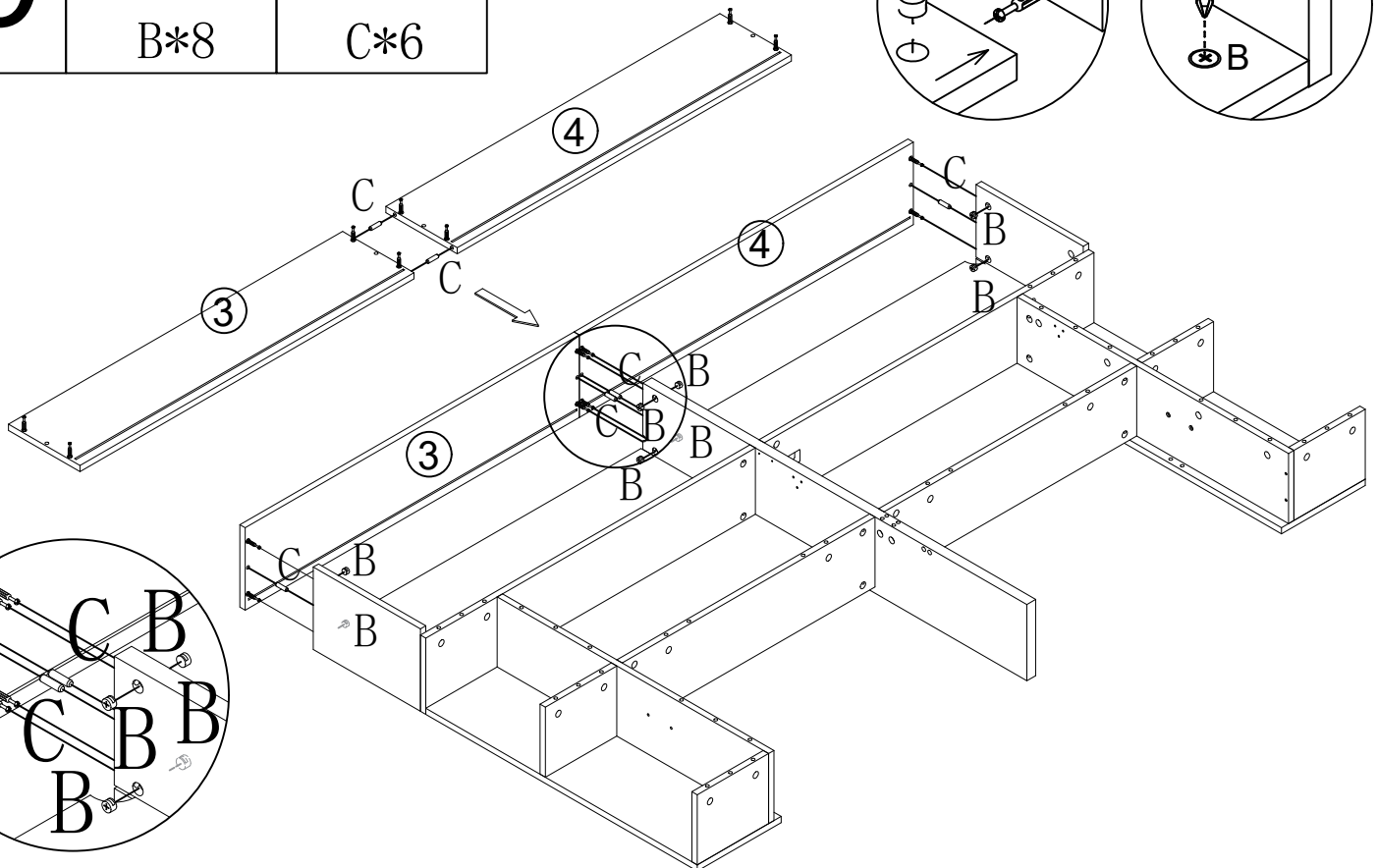
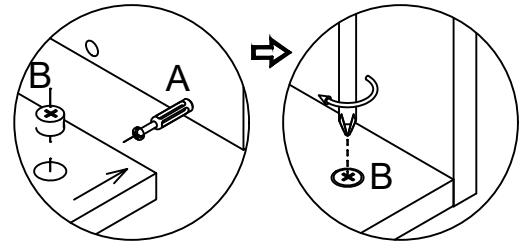

# 20



B\*4



C\*1



I\*4



F\*4

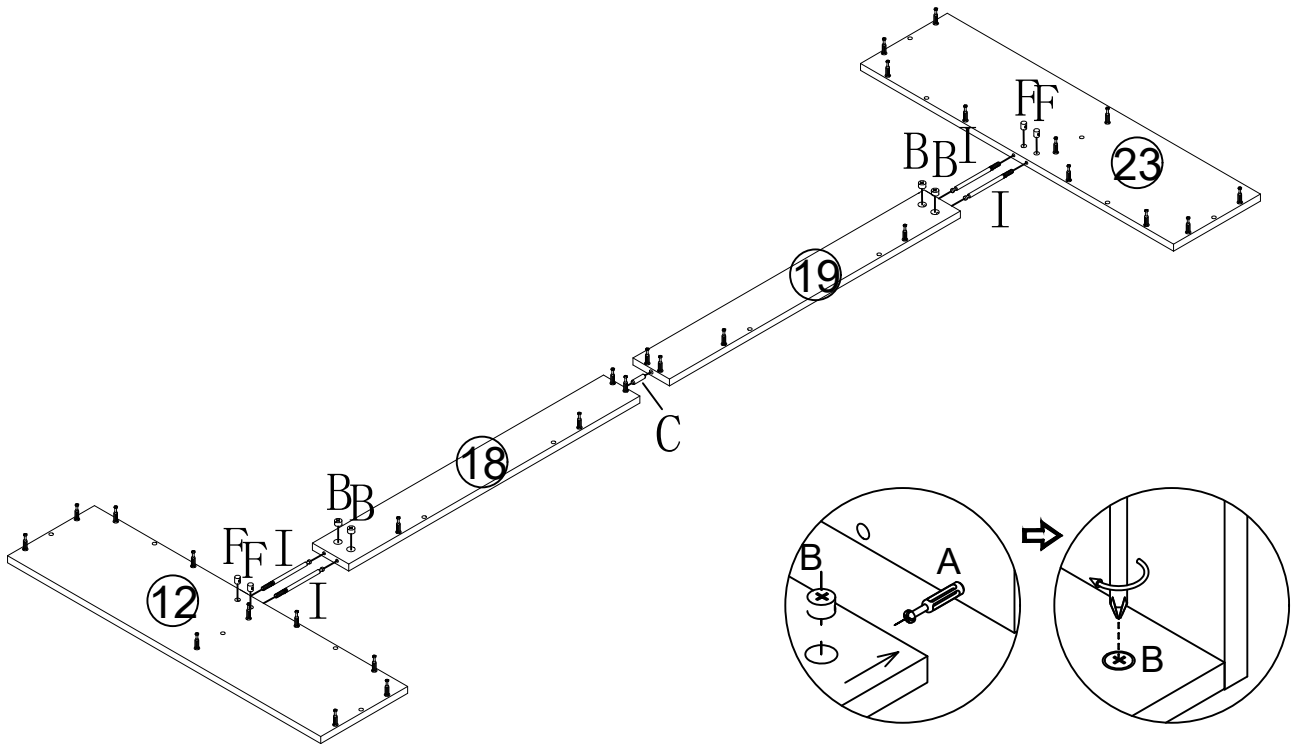

# 21



C\*14

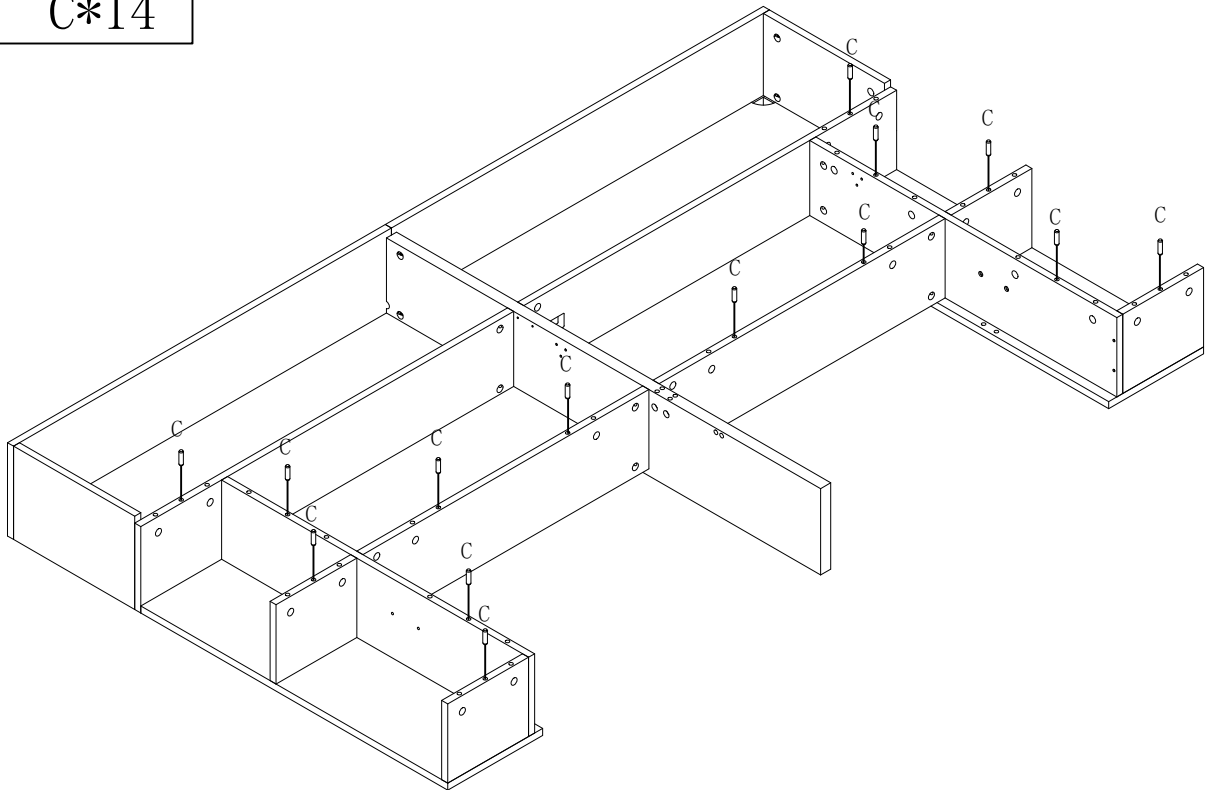

# 22



B\*28

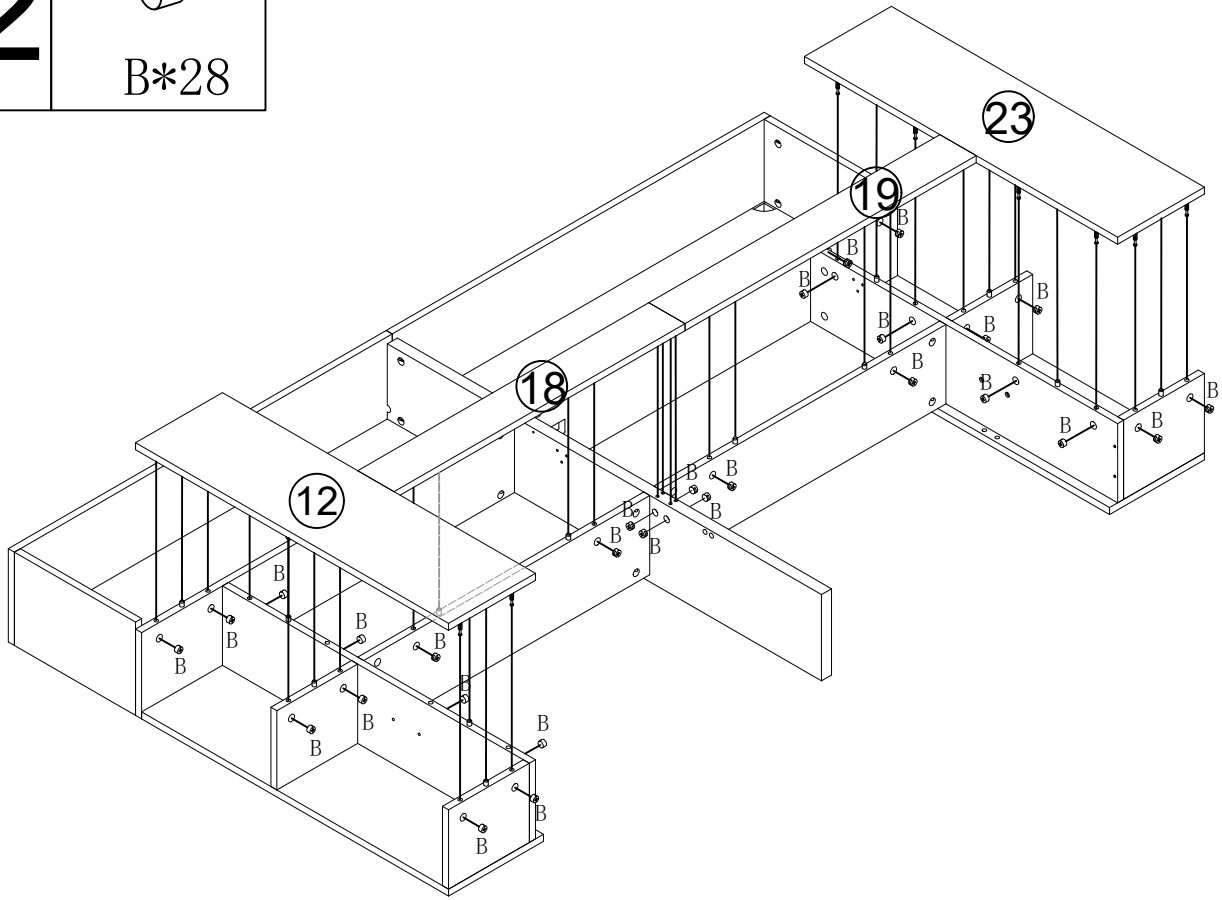

# 23



0\*24



U\*24

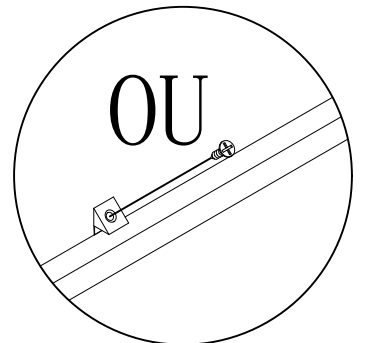
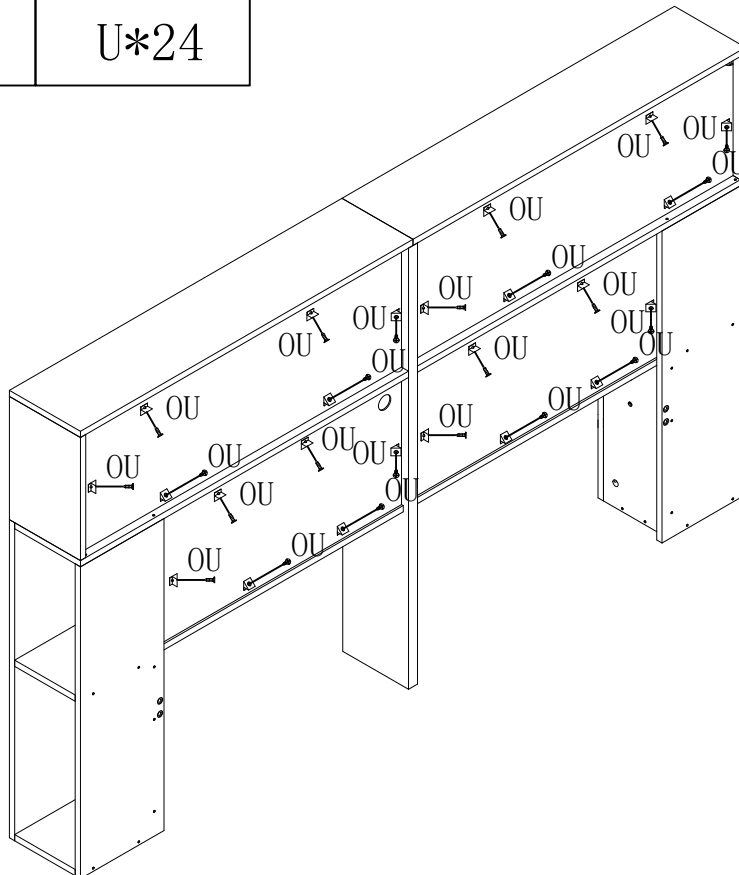

# 24



C\*4

H\*4

J\*8

K\*8

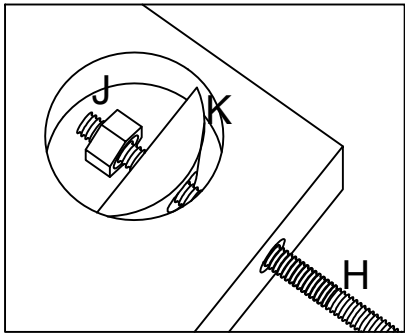
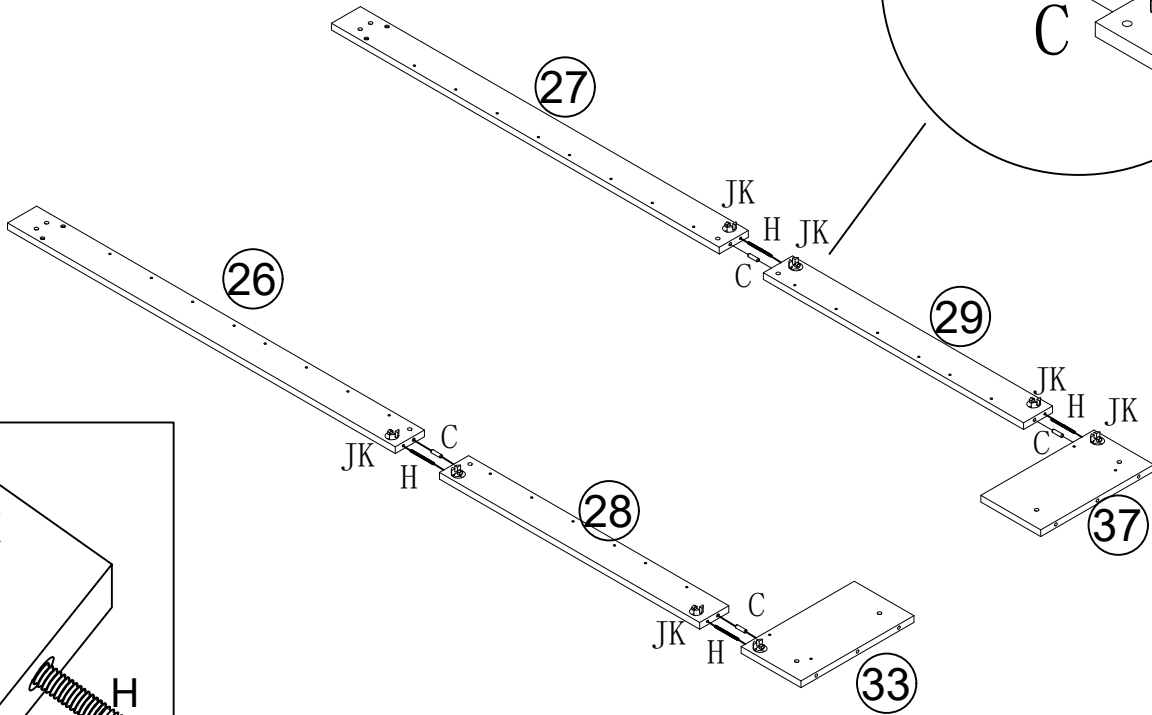
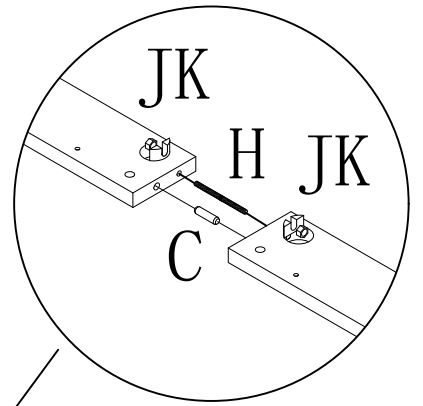

# 25

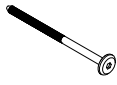

G\*4

F\*4

6\*14mm  
E\*4

6\*20mm  
D\*4

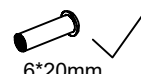

6\*20mm

6\*14mm



6\*40mm

6\*50mm

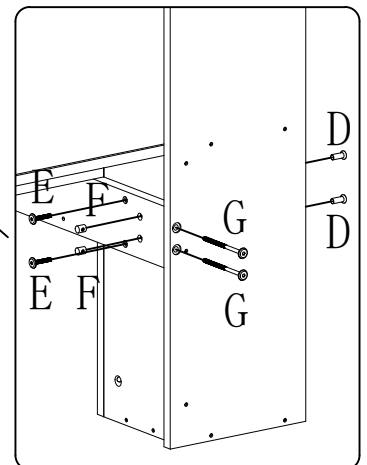
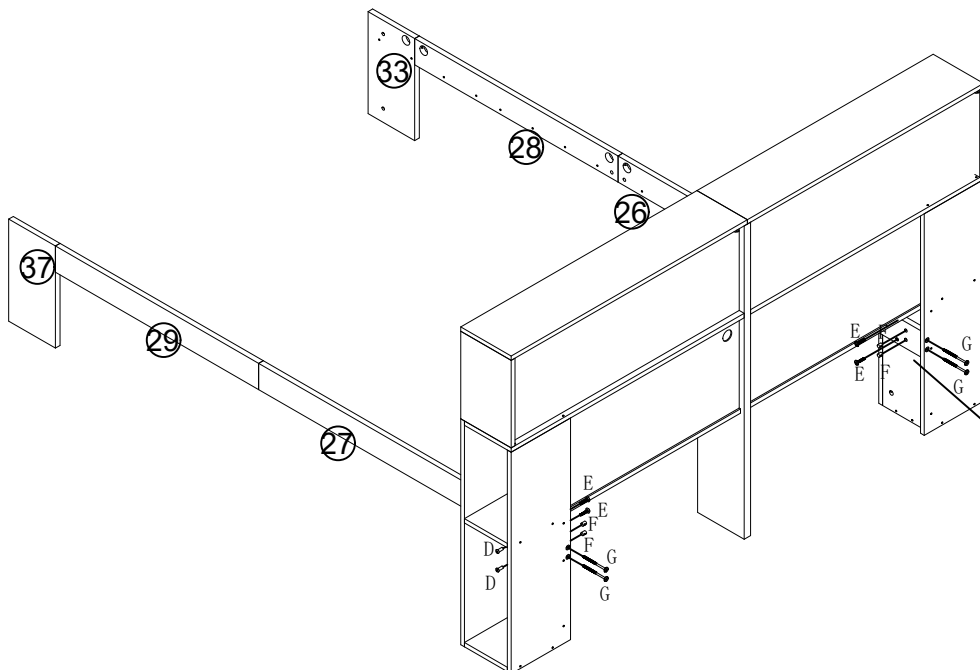

# 26



B\*2



C\*1

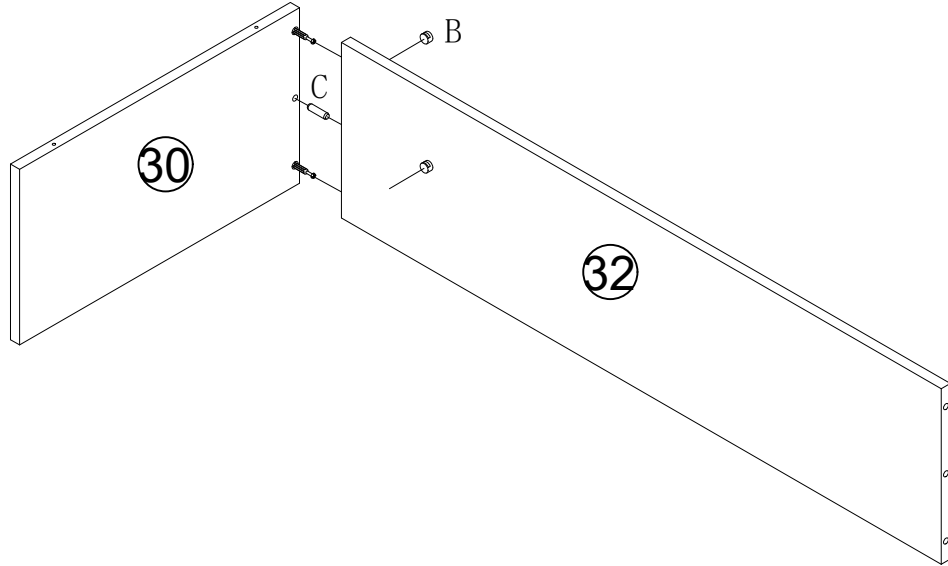

# 27

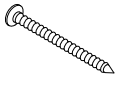

3.5\*25mm  
N\*10

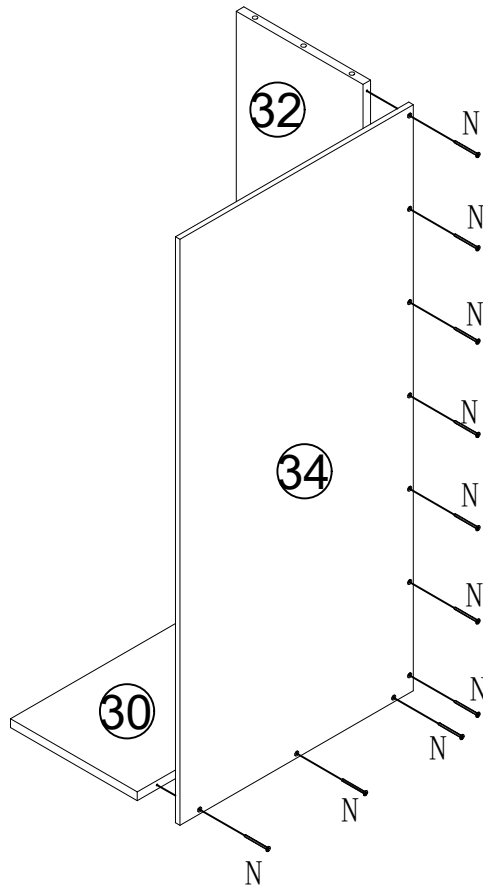

# 28



B\*2



C\*1

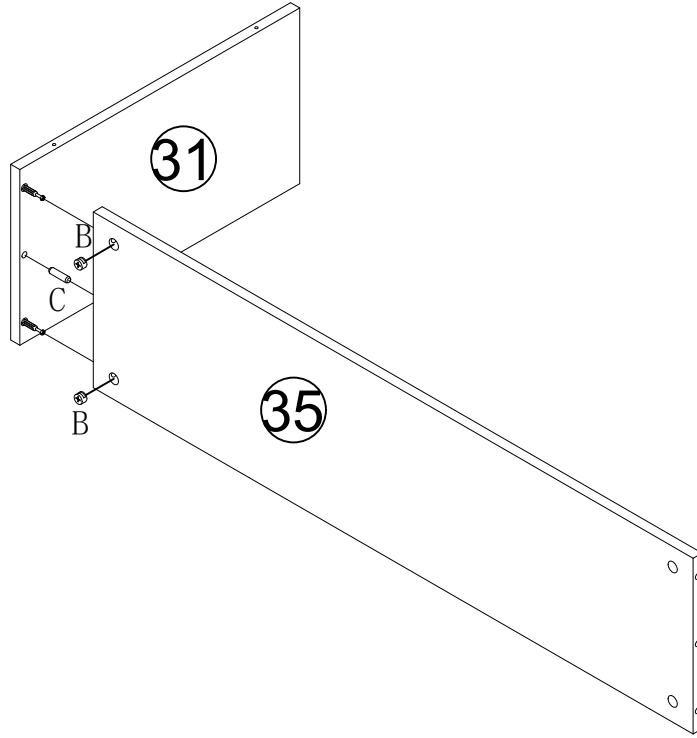

# 29

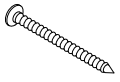

3.5\*25mm  
N\*10

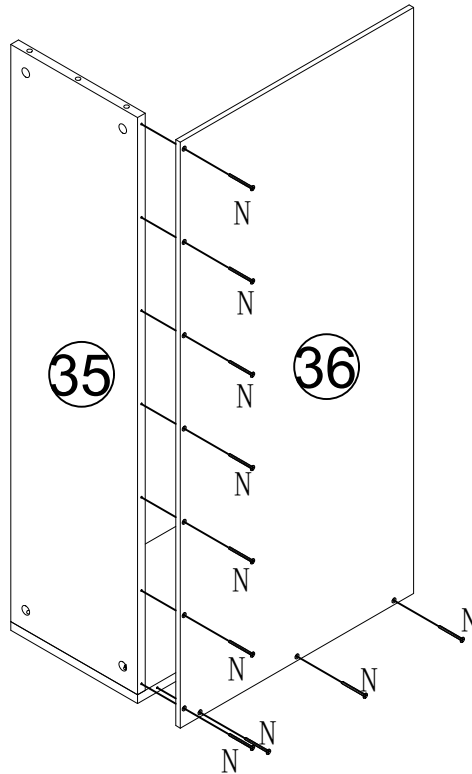

# 30



C\*3

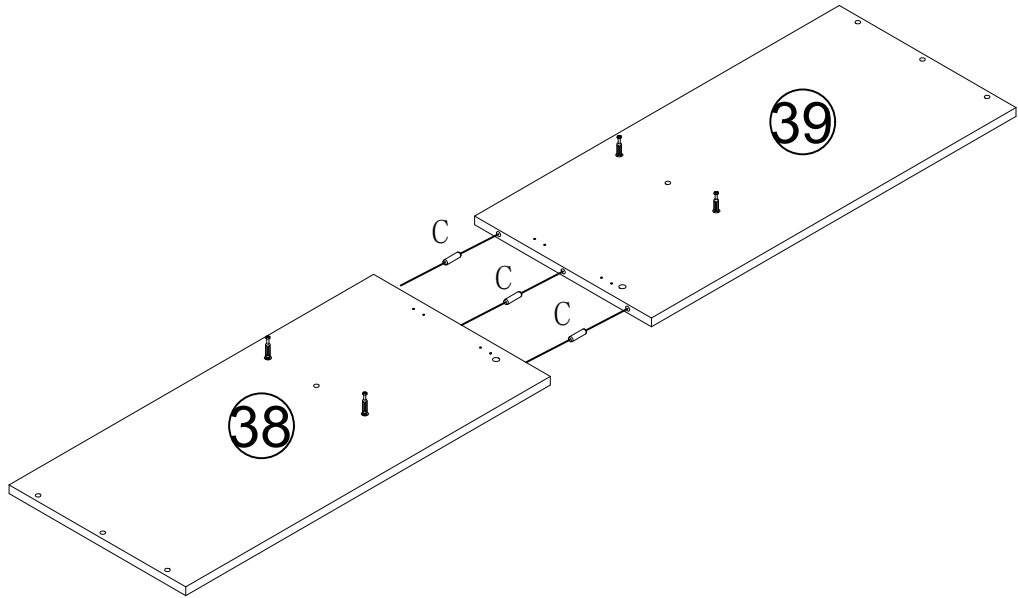

# 31



C\*4



B\*4



F\*4



G\*4

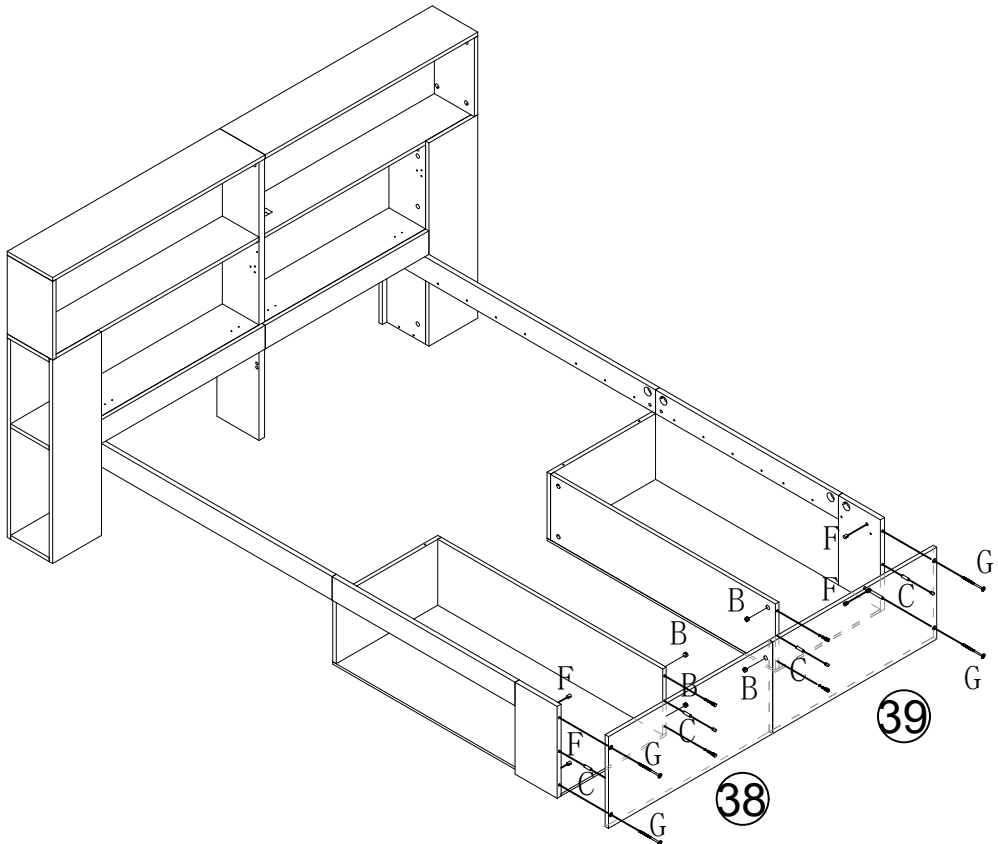

# 32

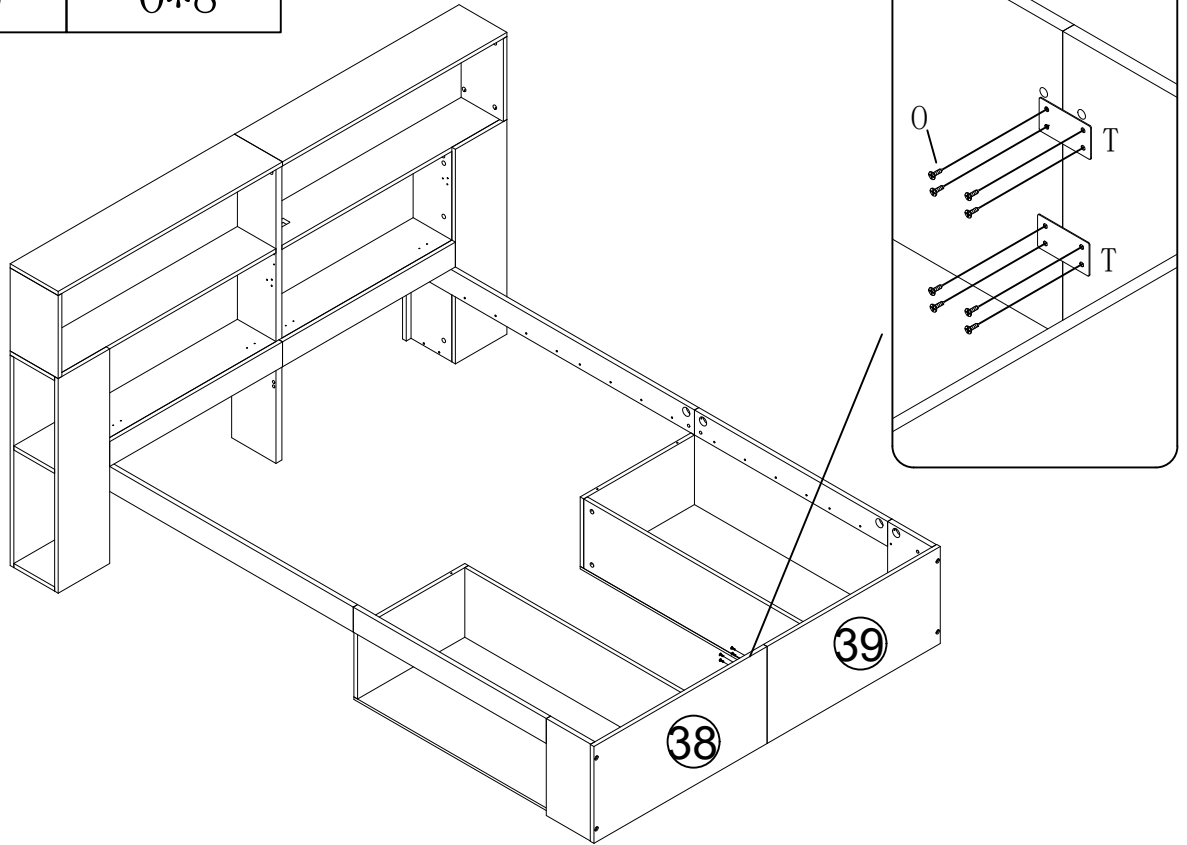
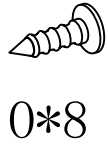
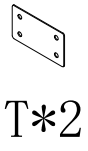

# 33

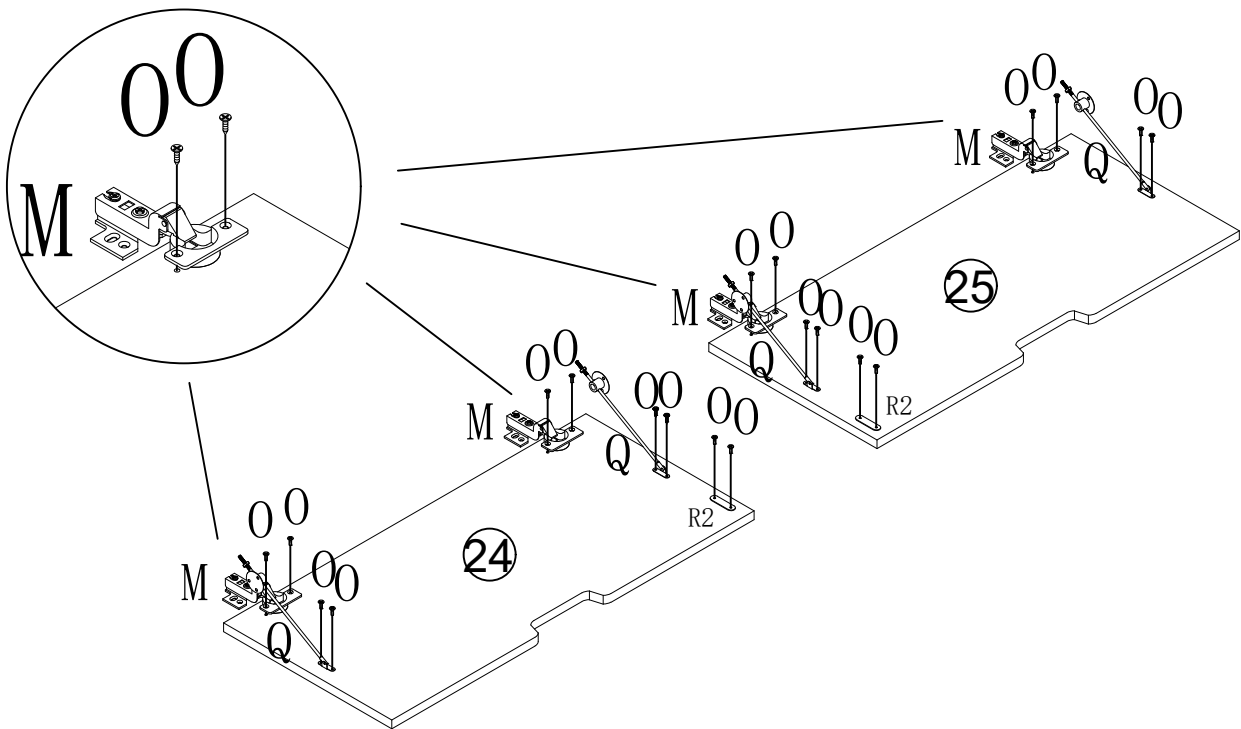
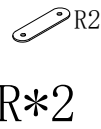

# 34

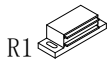

R\*2

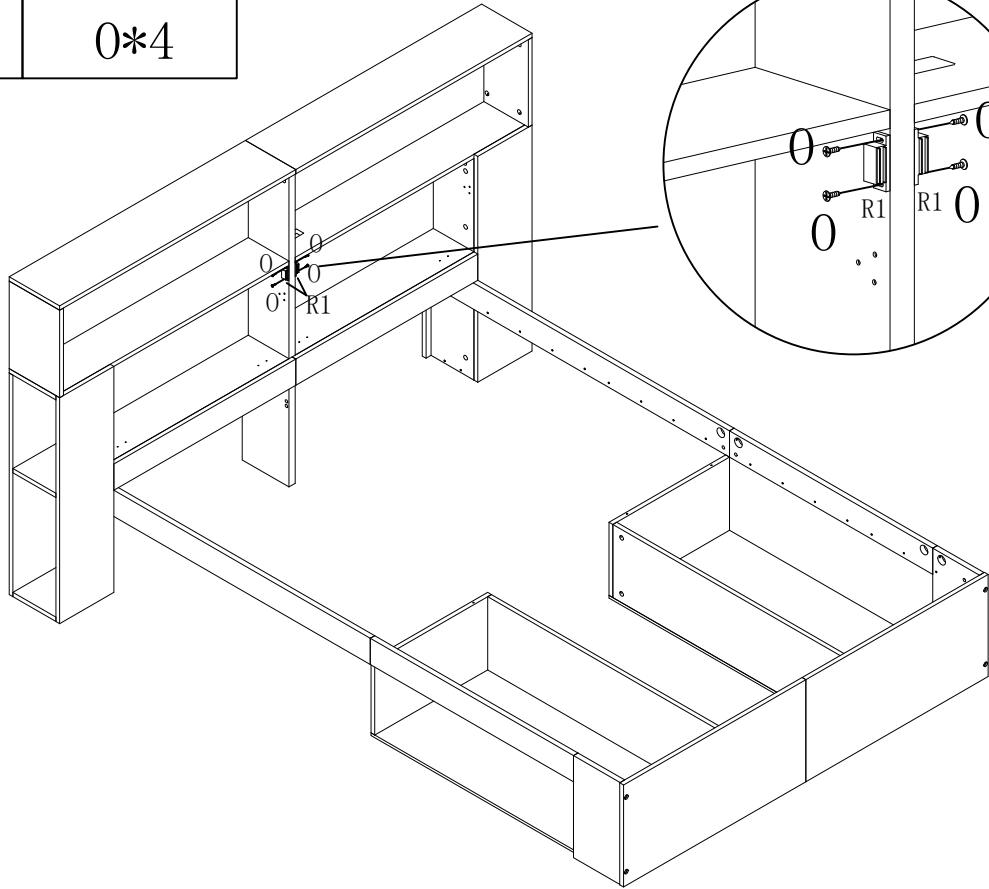

# 35



0\*16

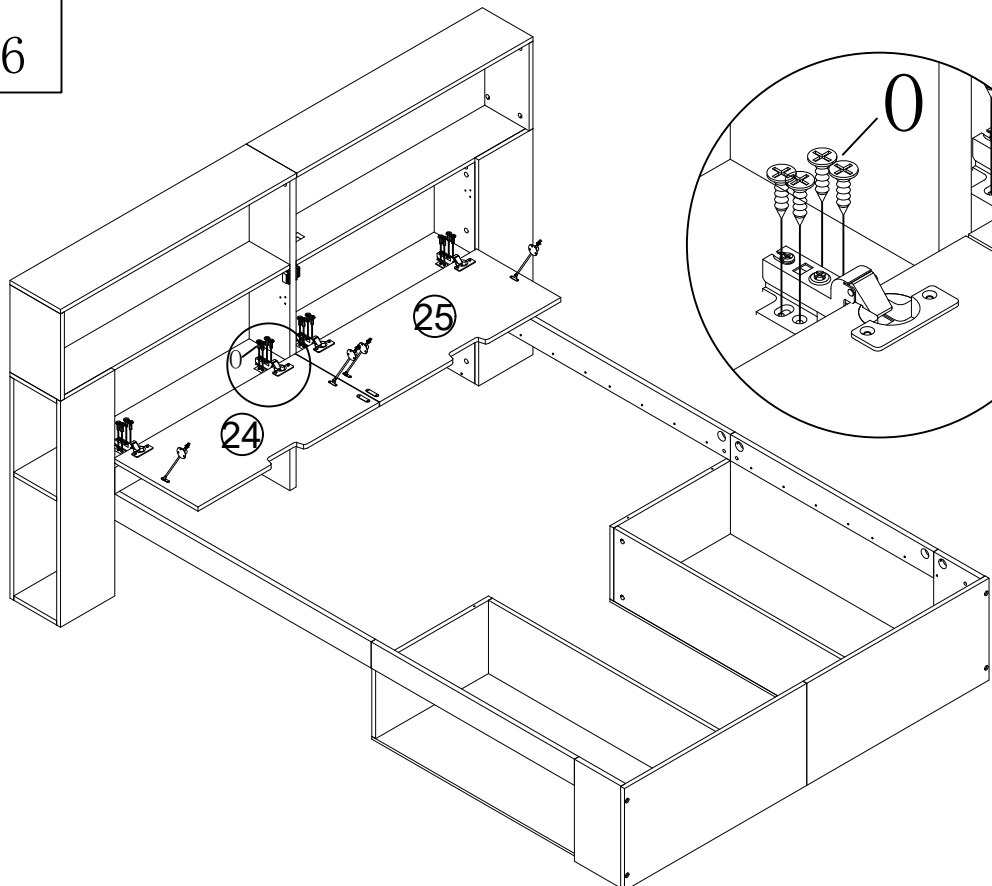

# 36



0\*12

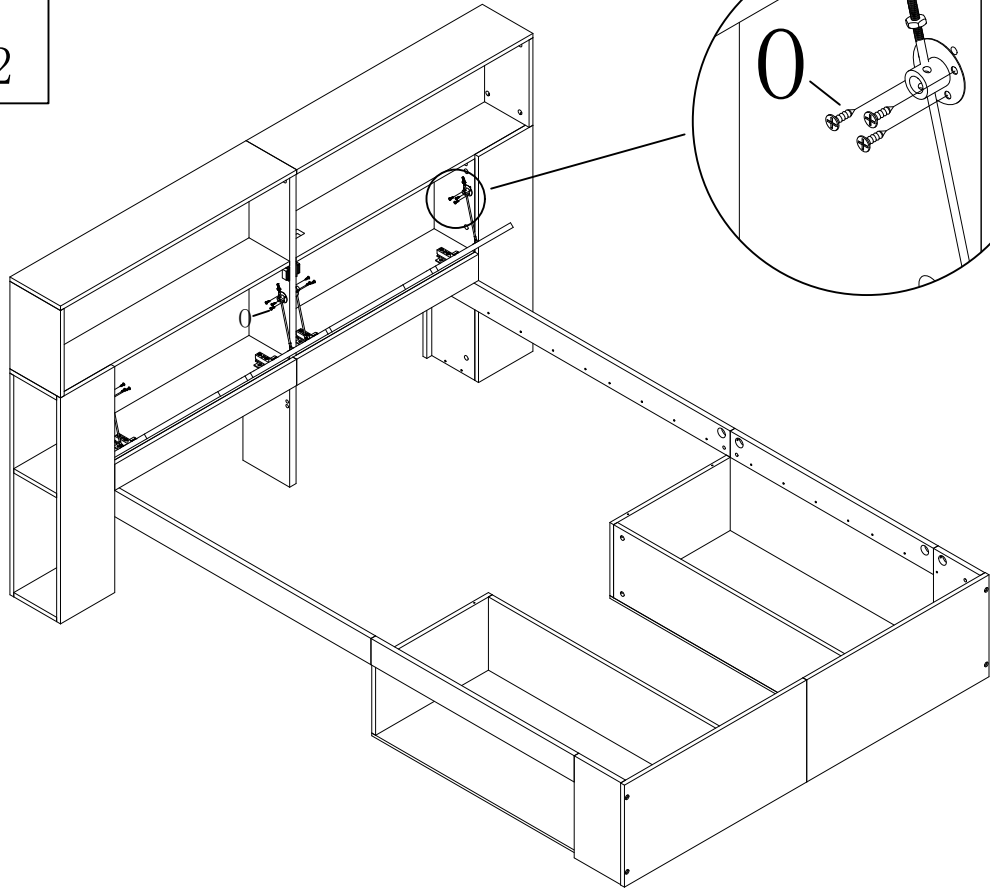

# 37



C\*2

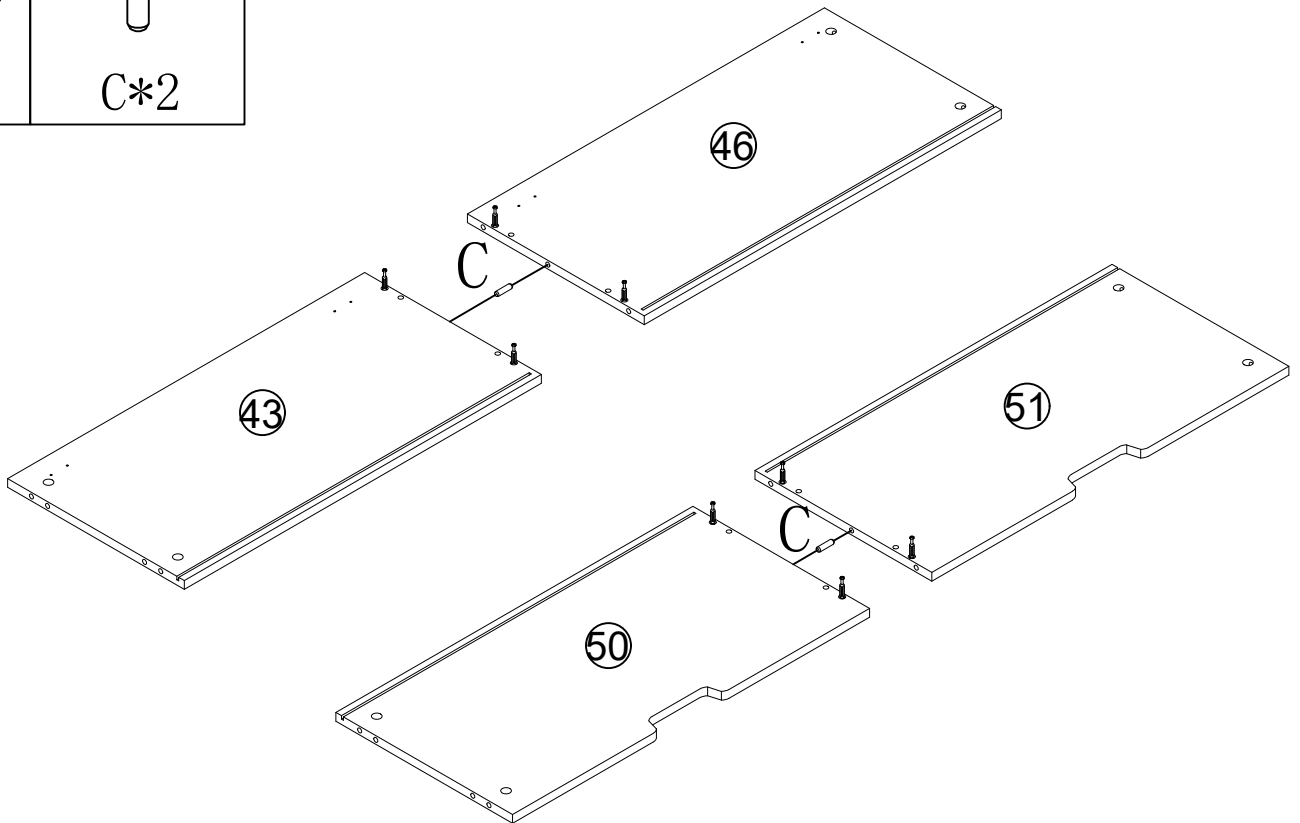

# 38

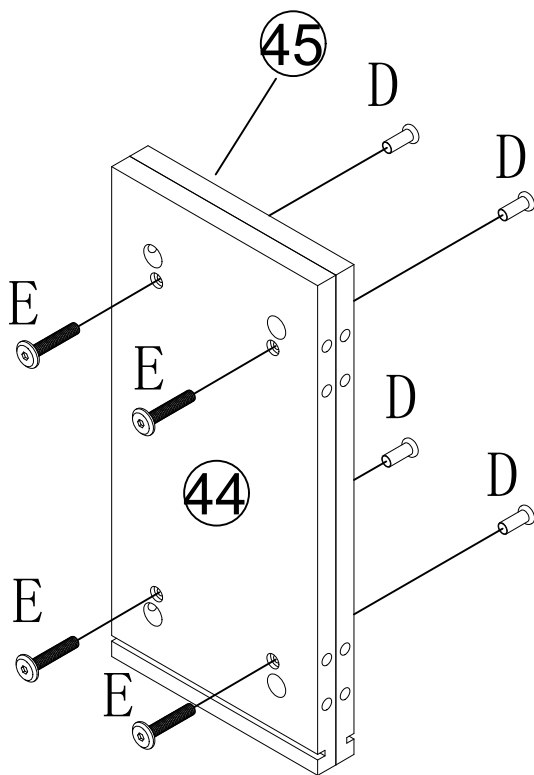
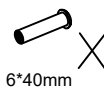
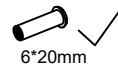

# 39

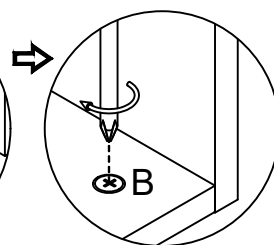
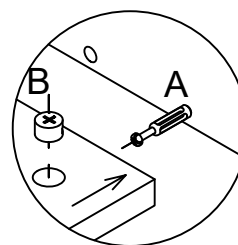
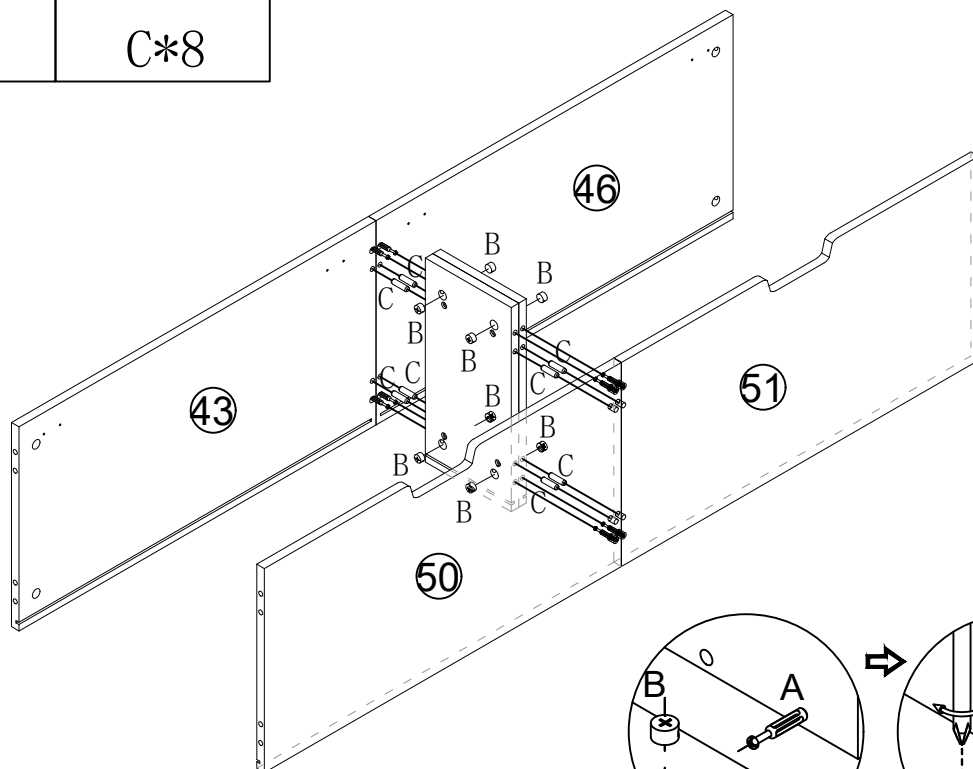
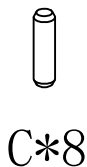

# 40

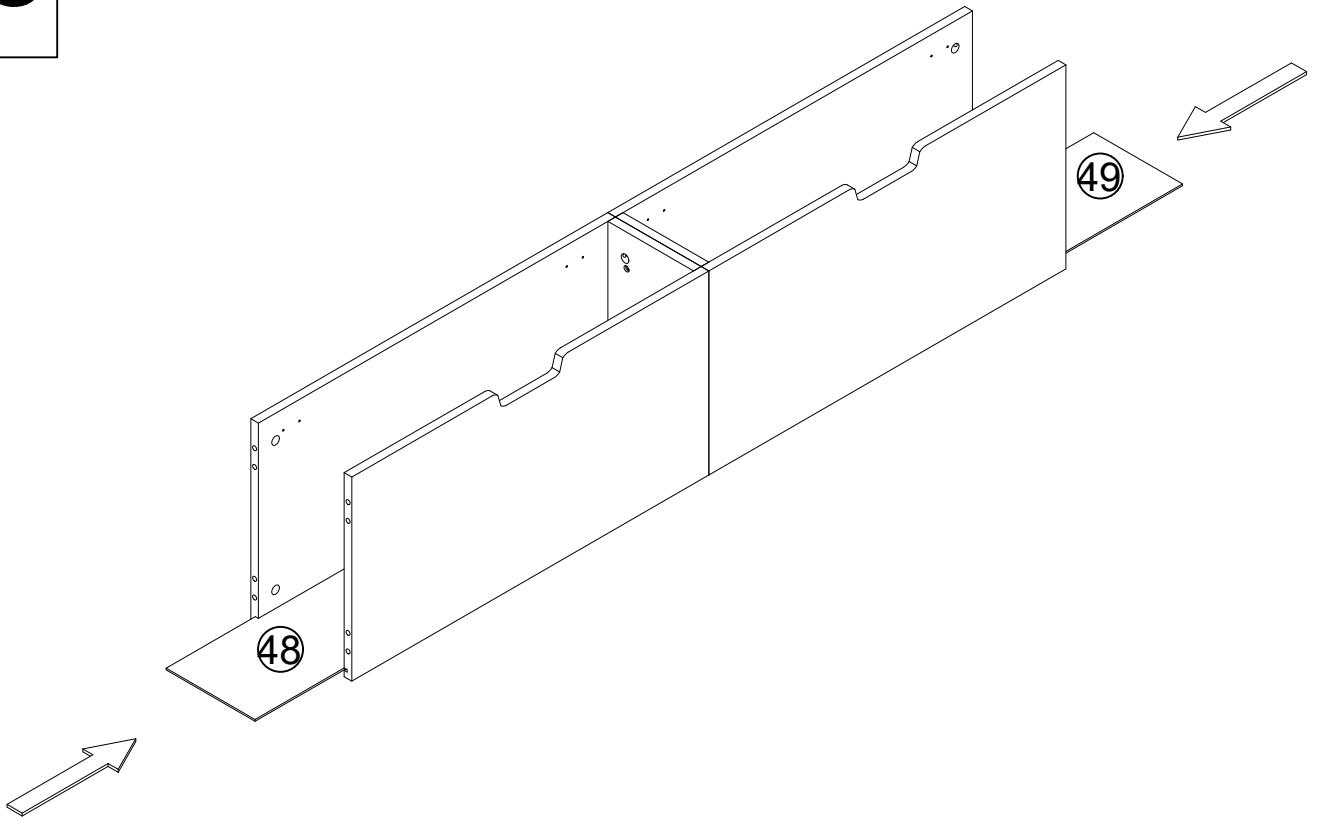

# 41



B\*8



C\*8

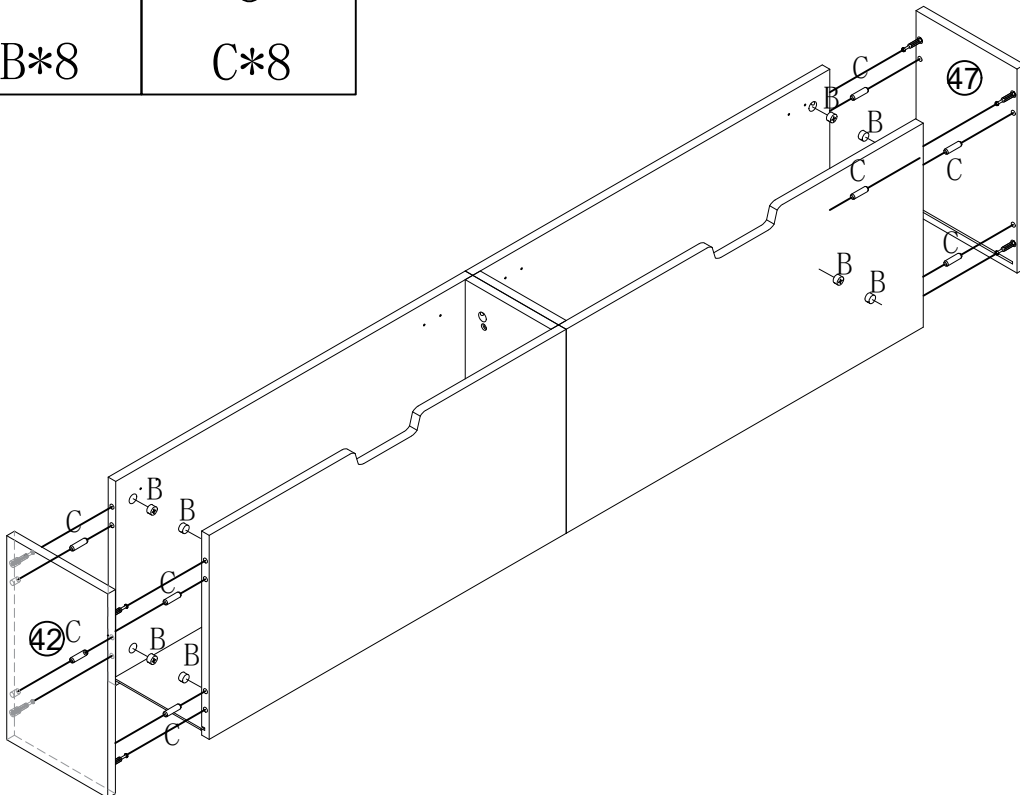

# 42



0\*8

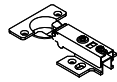

X\*4

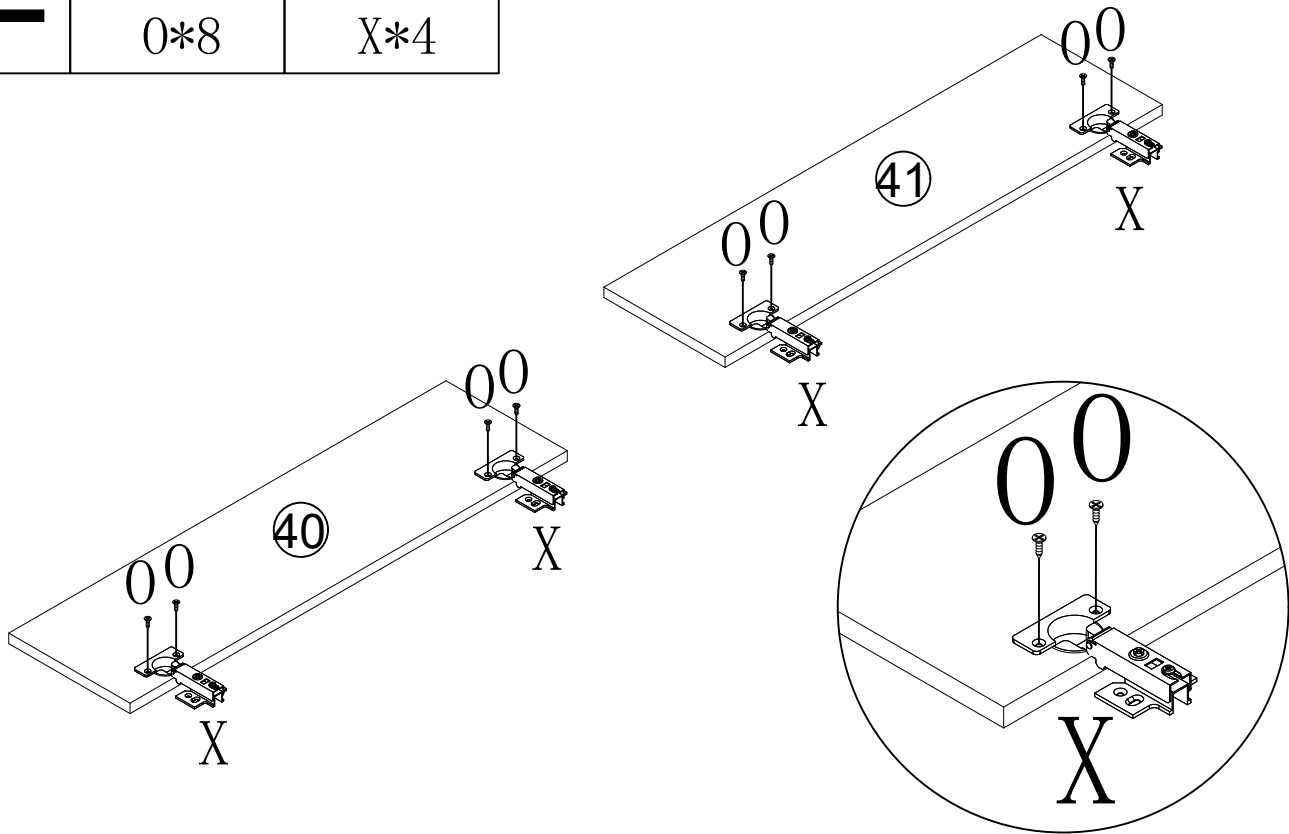

# 43



0\*16

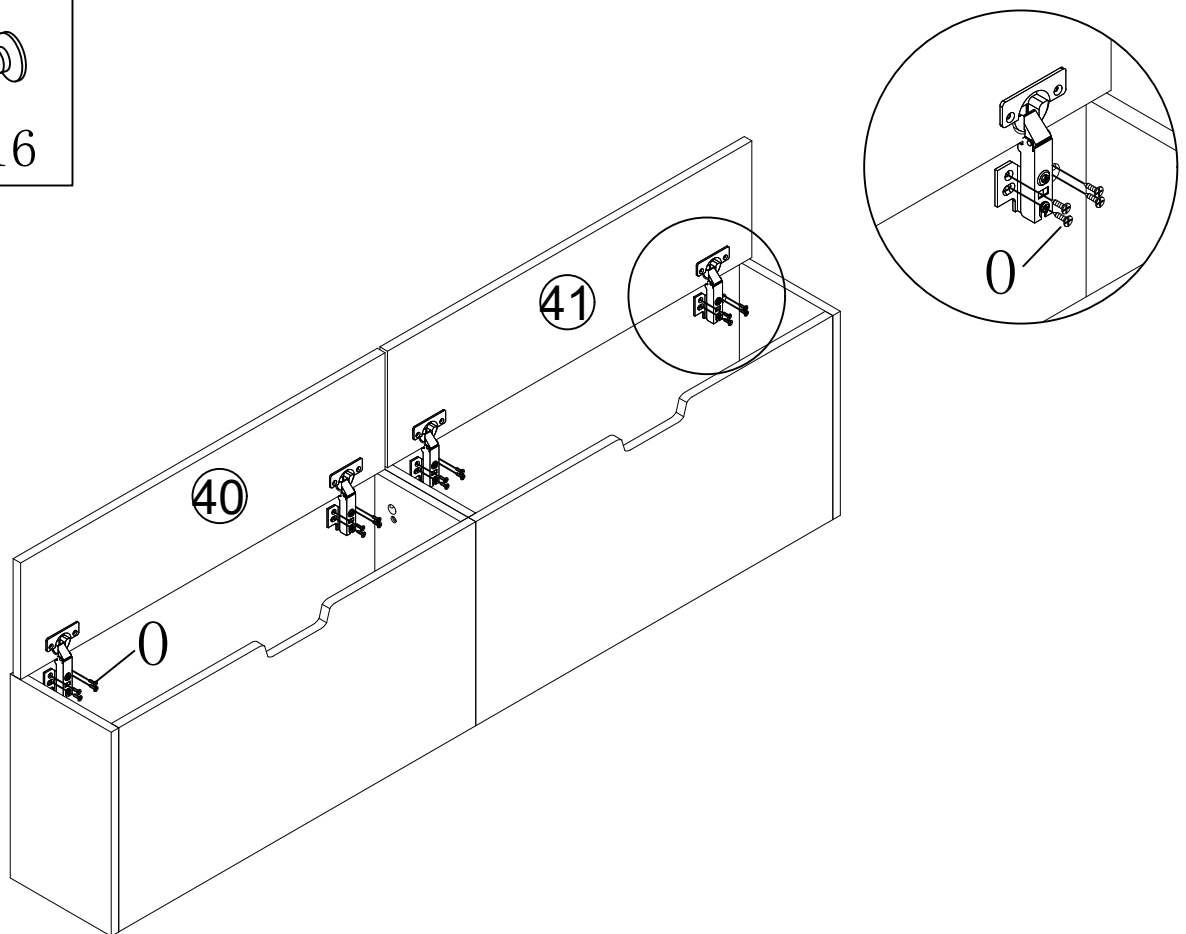

# 44



J\*2



6\*70mm  
AA\*2

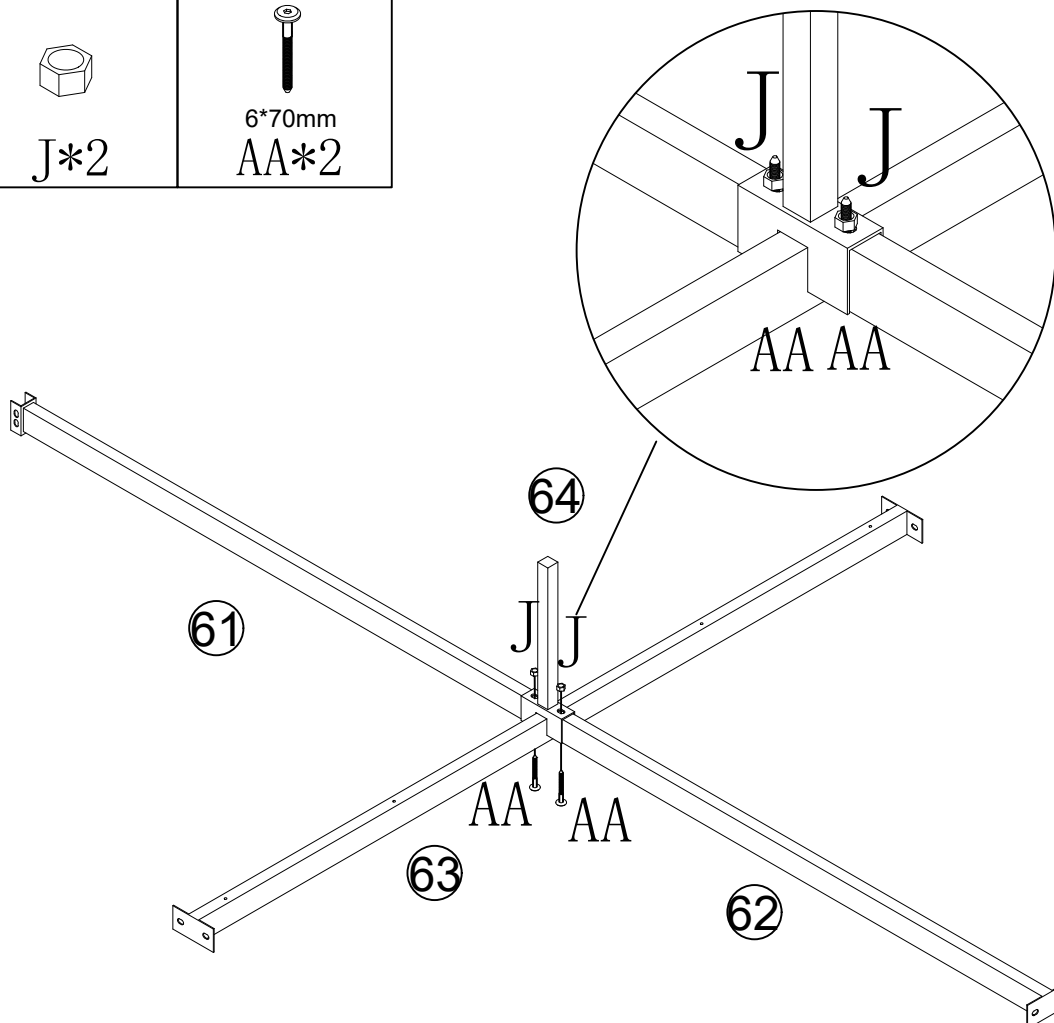

# 45



6\*12mm  
S\*10

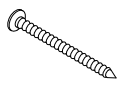

4\*50mm  
GG\*4



6\*70mm  
AA\*1

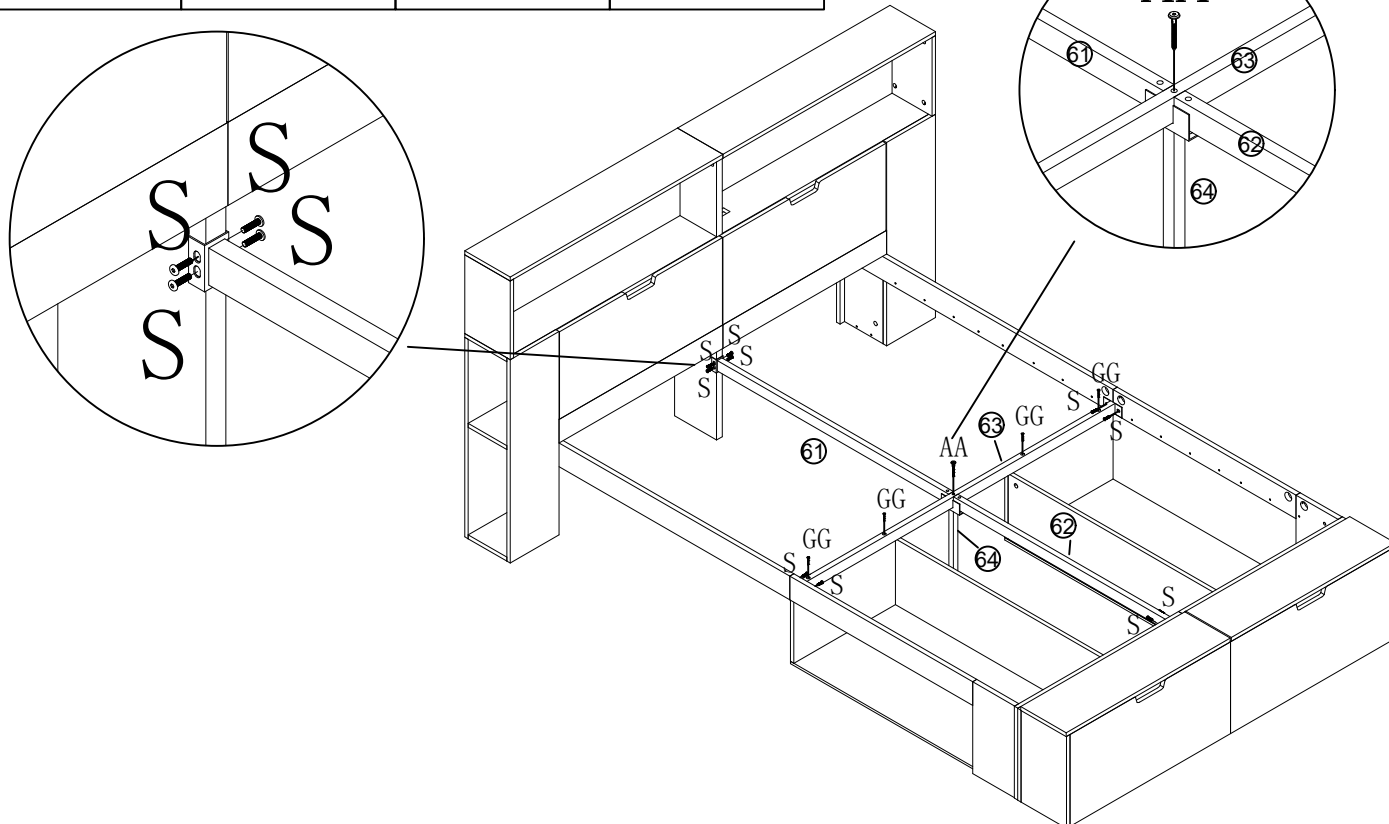

# 46

4\*30mm  
P\*32

FF\*4

O\*4

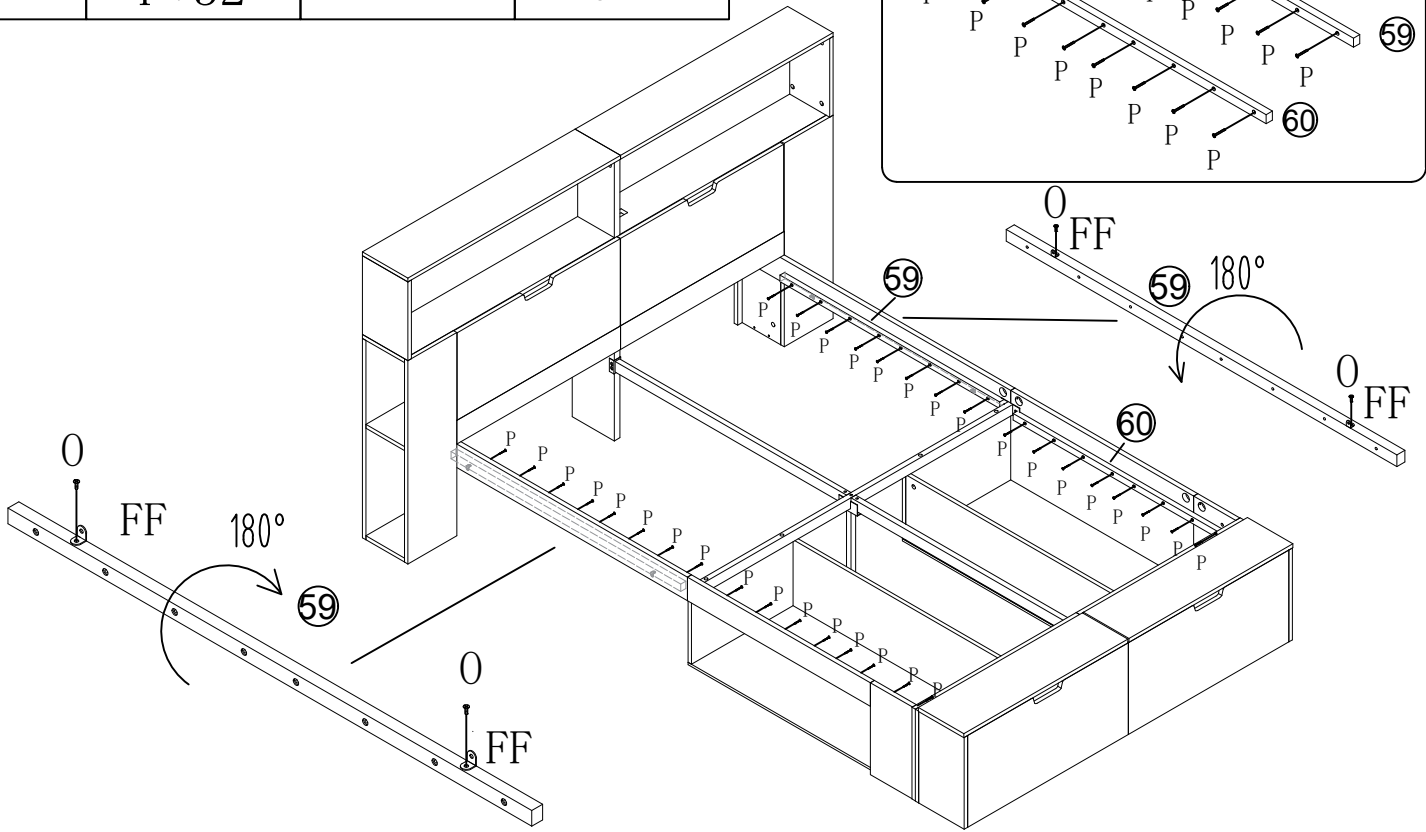
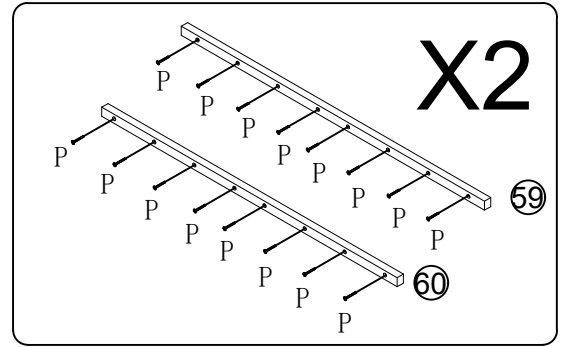

# 47

4\*30mm  
P\*32

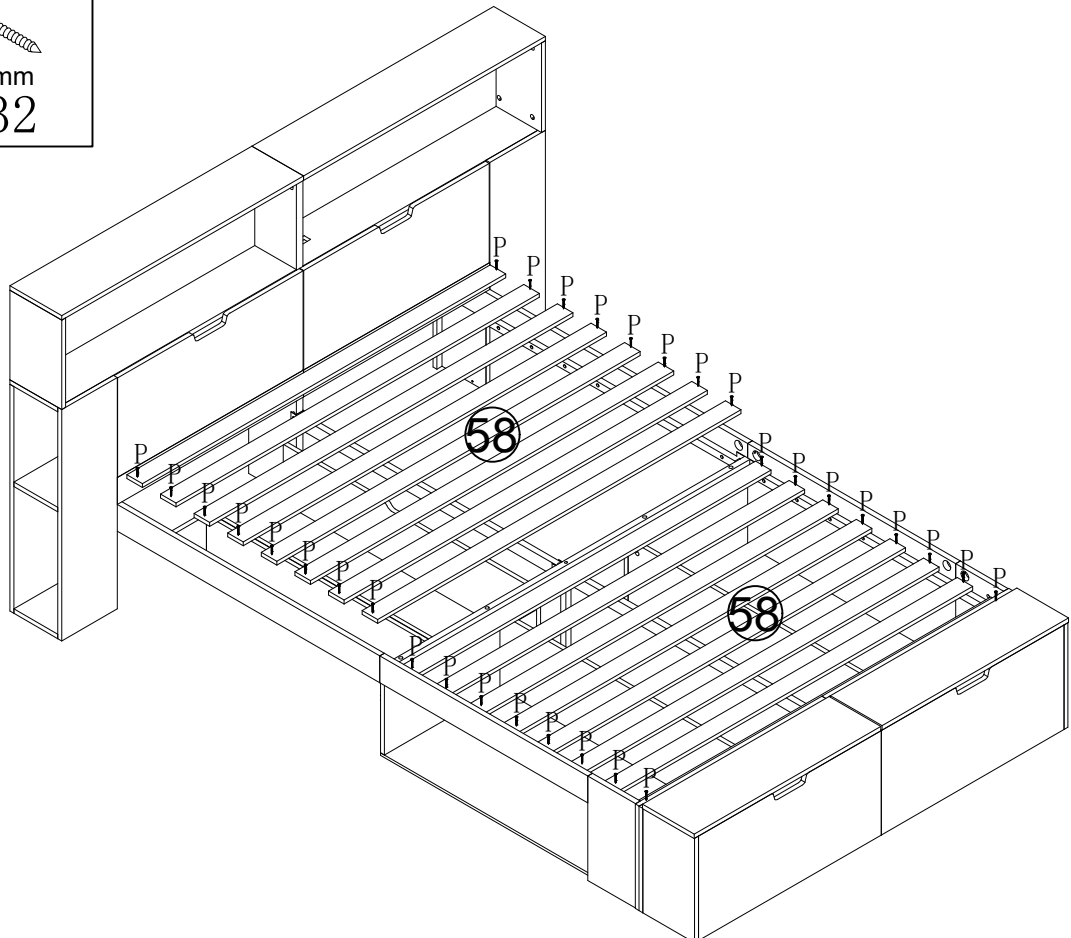



50



W\*8



0\*16

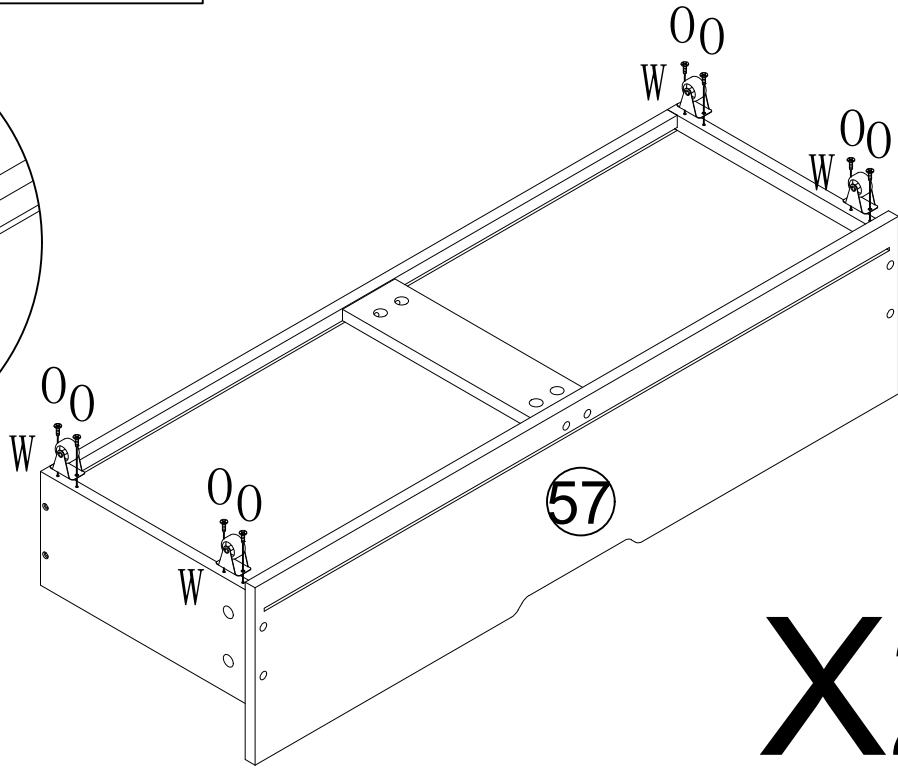
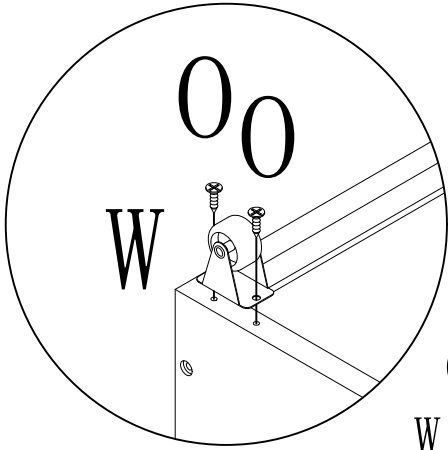

51

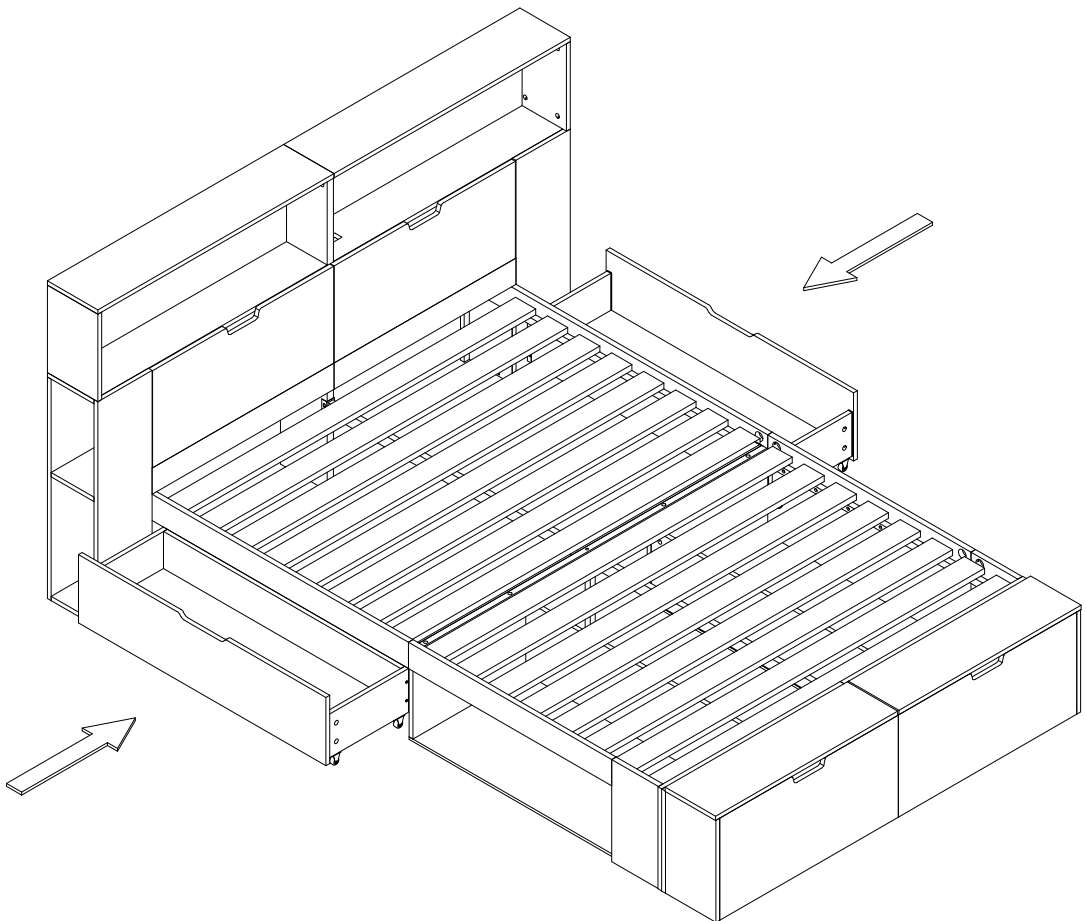

52

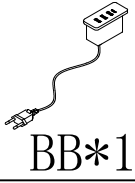

BB\*1



0\*2

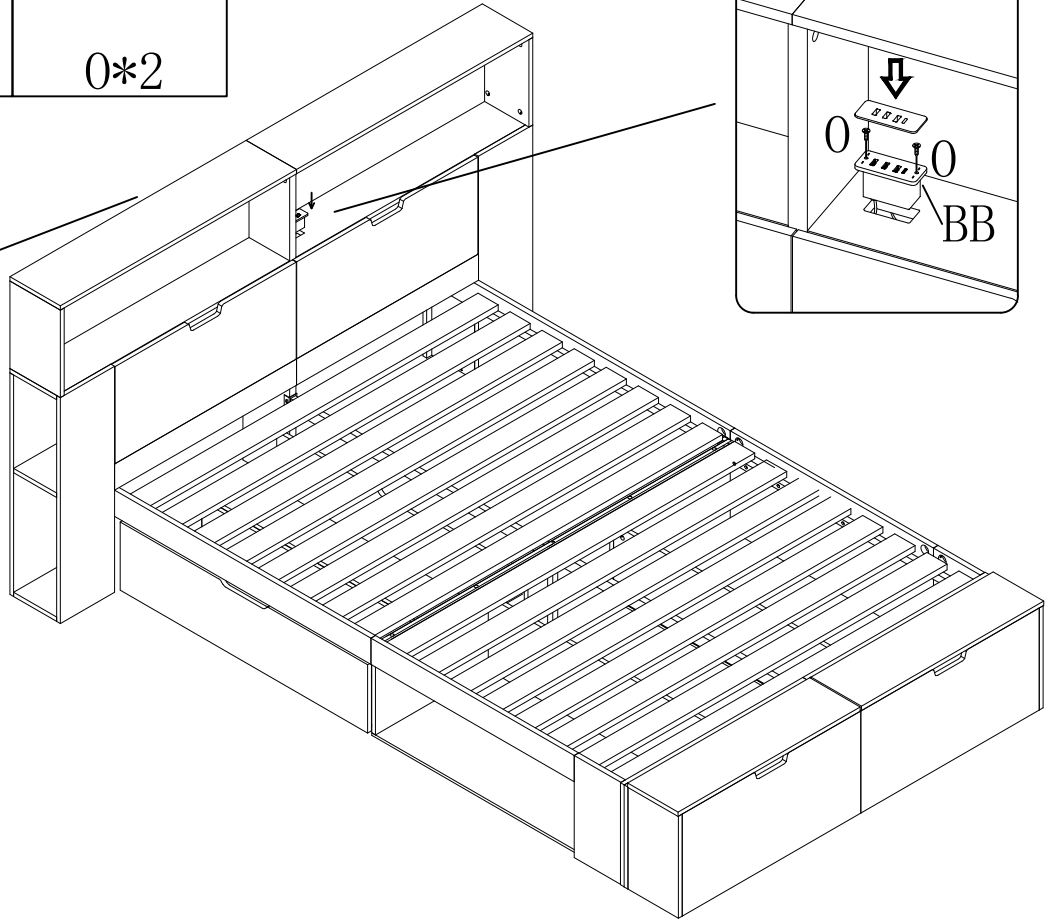
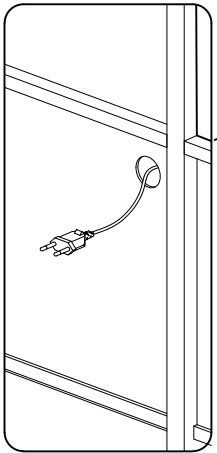
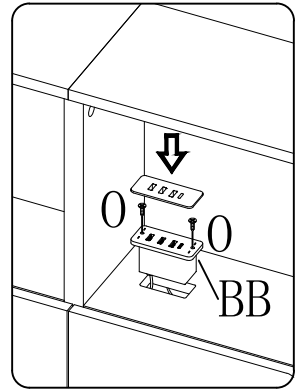

53



CC\*1

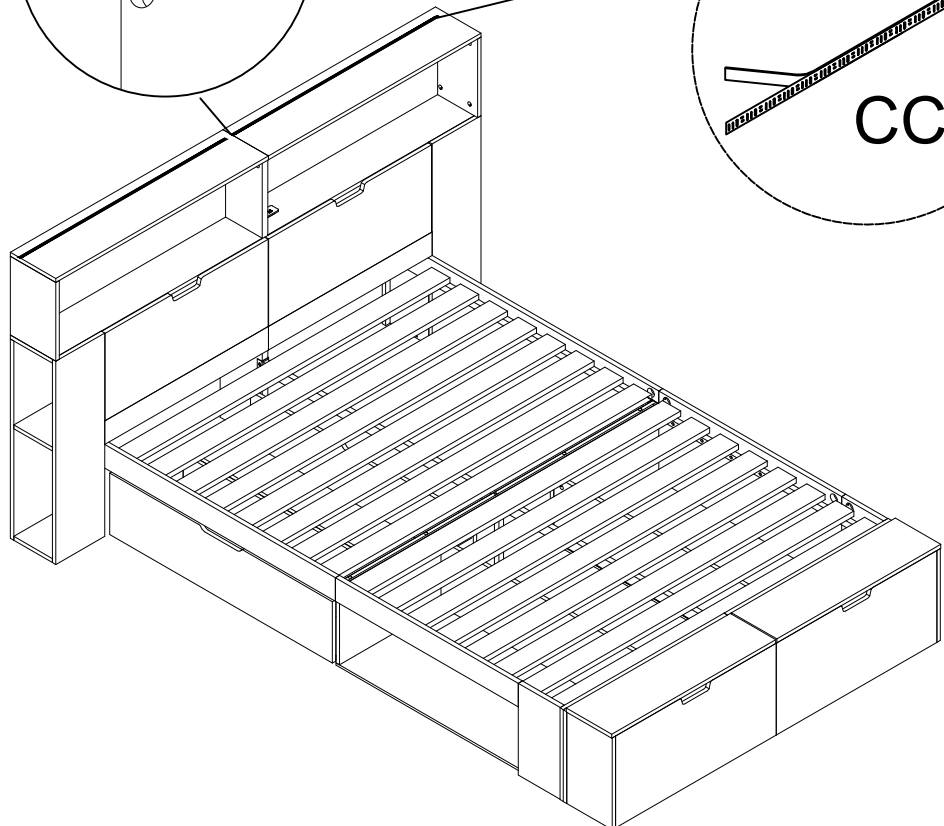
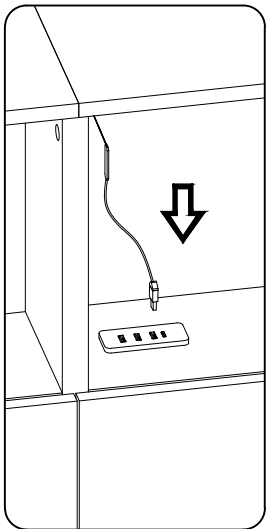
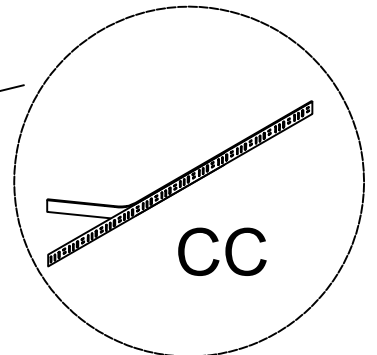
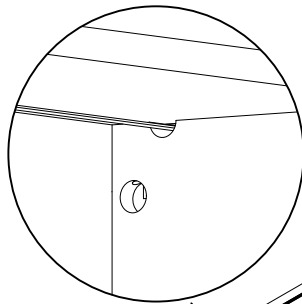

# 54



DD\*100

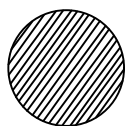

EE\*8

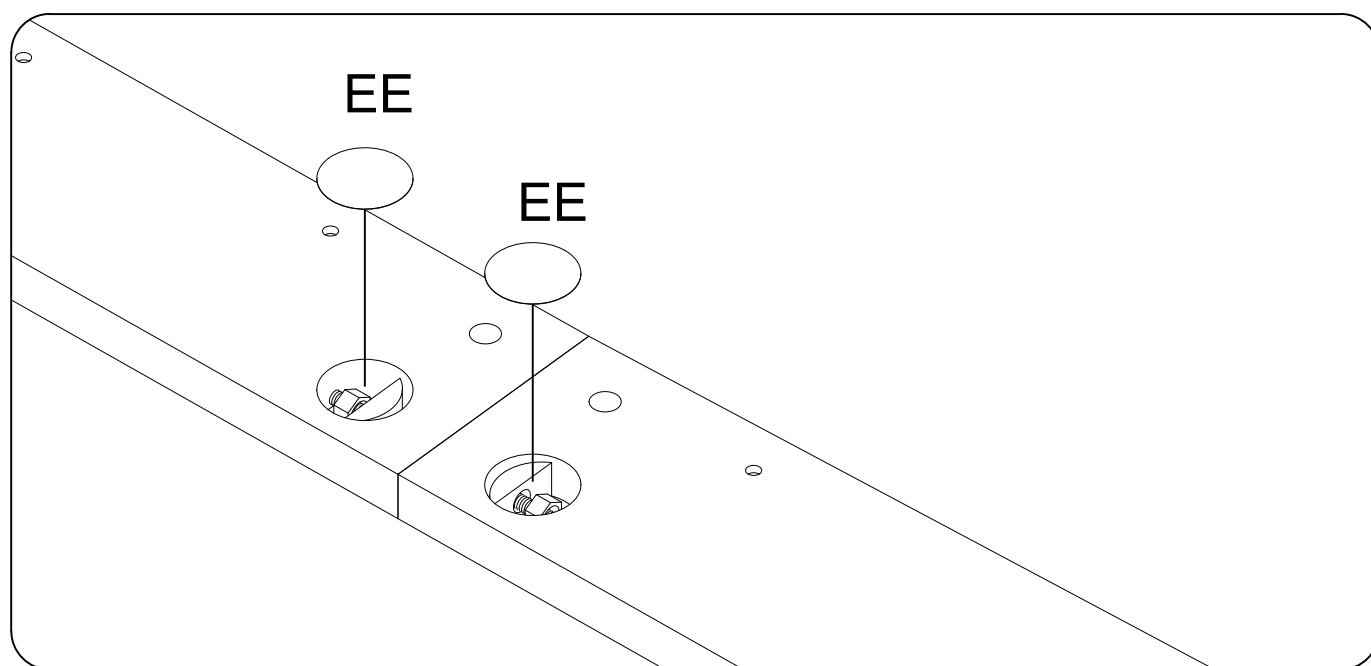
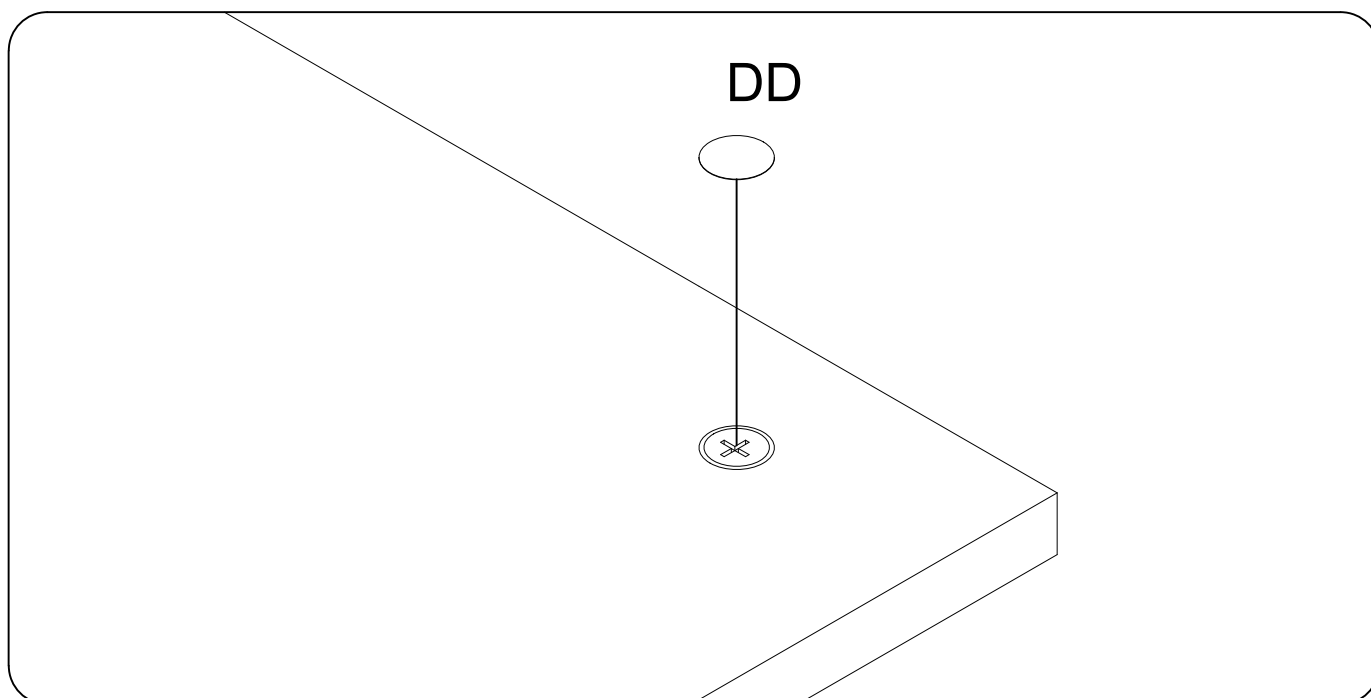

GB: After installing the product, stick the number DD EE on the perforated position

FR: Une fois le produit installé, collez le numéro DD EE à l'endroit où il y a des trous

DE: Nach der Installation des Produkts kleben Sie die Nummer DD EE auf die perforierte Position

Shenzhen ZKT Technology Co., Ltd.  
 1/F, No. 101, Building B, No. 6, Tangwei Community Industrial Avenue,  
 Fuhai Street, Bao'an District, Shenzhen, China



# Certificate of Compliance

Certificate Number: ZKT-250902L21449C

**Certificate's Holder** : Shenzhen Lanling Optoelectronics Technology Co., Ltd  
 511-G5, Building C, No. 101 Fukang Road, Henggang Community,  
 Henggang Street, Longgang District, Shenzhen City, Guangdong  
 Province

**Manufacturer** : Shenzhen Lanling Optoelectronics Technology Co., Ltd  
 511-G5, Building C, No. 101 Fukang Road, Henggang Community,  
 Henggang Street, Longgang District, Shenzhen City, Guangdong  
 Province

**Trade Mark** : /

**Product** : LED Strip

**Model(s)** : CWG-5050RGB-60D-5V  
 LED5050X18, LED5050X30, LED5050X48, LED5050X72, LED5050X90,  
 LED5050X120, LED2835X30, LED2835X60, LED2835X120,  
 LED2835X180, LED2835X240, LED3528X30, LED3528X60,  
 LED3528X120, LED3528X240, LED5730X60, LED5730X72, LED5730X84,  
 LED3535X60, LED3535X120

**Test Standard** : EN IEC 55015:2019+A11:2020  
 EN IEC 61000-3-2:2019 + A1:2021 + A2:2024  
 EN 61000-3-3:2013 + A1:2019 + A2:2021  
 EN IEC 61547:2023

This Attestation of Compliance is issued on a voluntary basis for electrical equipment below the voltage limits of EMC Directive 2014/30/EU. The essential requirements are fulfilled accordingly based on the technical specifications applicable at the time of issuance. See also notes overleaf. It is only valid in connection with the test report number: ZKT-250902L21449E.



This Certificate of Conformity is based on single evaluation of the submitted sample(s) of the above mentioned product. It does not imply an assessment of the whole product and relevant . Directives to be observed.



KeySense Testing & Certification International Co., Ltd.  
 1-3F, Lab Building, No.29 District, Zhongkai Hi-Tech  
 Industrial Development Park, Huizhou, Guangdong,  
 China

Tel:0752-3219929  
 Fax:0752-3219929  
<http://www.kst-cert.com>

# Technical Compliance Statement

Certificate No.: KST240304E008Q01

Report No.: KST240304E008Q01

The following product has been tested by us with the listed standards and found in Compliance with the council EMC directive 2014/30/EU. It is demonstrative for the Compliance with this EMC Directive.

**Holder:** DONGGUAN BAIYOU ELECTRONIC CO LTD  
**Address:** 2F A Building, Wufeng Industrial, Jintan Road, Danwu Shijie Town, Dongguan, Guangdong  
**Product:** USB CHARGER  
**Model Name:** BY213-TD04-C  
**Trade Name:** N/A

Test Standard	
EN 55032:2015+A1:2020	Electromagnetic compatibility of multimedia equipment – Emission requirements
EN IEC 61000-3-2:2019+A1:2021	Electromagnetic Compatibility (EMC) Part 3-2:Limits-Limits for harmonic current emissions(equipment input current ≤ 16A per phase)
EN 61000-3-3:2013+A2:2021	Electromagnetic Compatibility(EMC) Part 3-3:Limits-limitation of voltage changes, voltage fluctuations and flicker in public low-voltage supply systems, for equipment with rated current ≤ 16A per phase and not subject to conditional connection
EN 55035:2017+A11:2020	Electromagnetic compatibility of multimedia equipment – Immunity requirements



Signature:

Name:

Jack.Li

Position:

Supervisor

Date:

April 26, 2024

The statement is based on single evaluation of one sample of above mentioned product. It does not imply an assessment of the whole production and does not permit the use of the test lab. Logo.