

ASSEMBLY INSTRUCTION

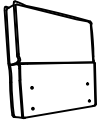

A*4PCS

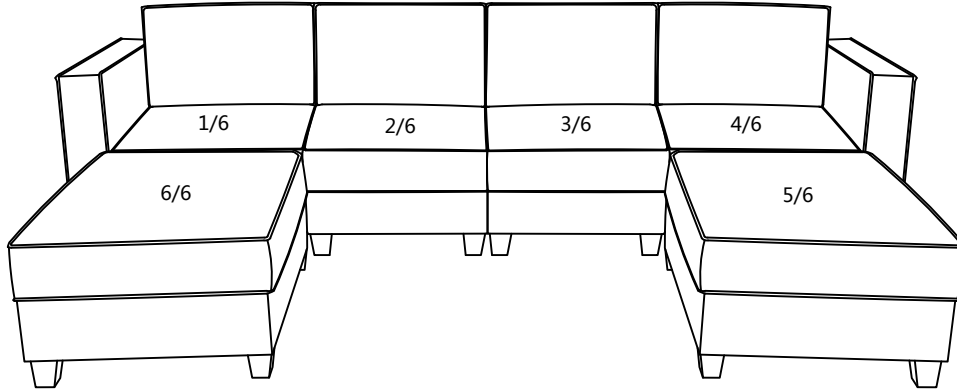
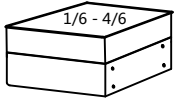

B*4PCS



C*1PC



D*1PC

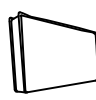

E*4PCS

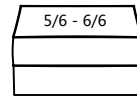

F*2PCS



G*4PCS



H*3PCS



I*24PCS



J*24PCS



K*16PCS



L*16PCS



M*16PCS



N*1PC



O*8PCS



P*1PC



Q*4PCS



R*1PC

STEP 1

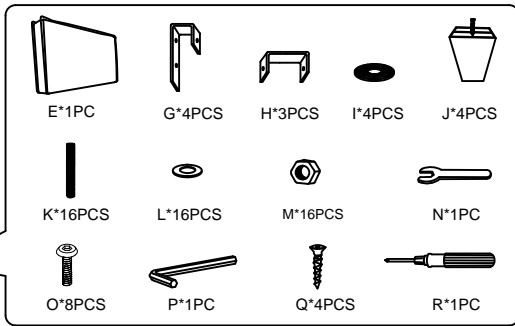
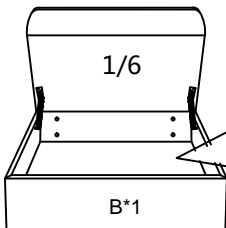

STEP 2

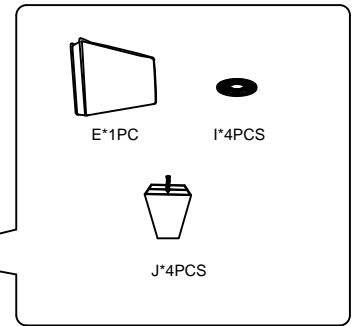
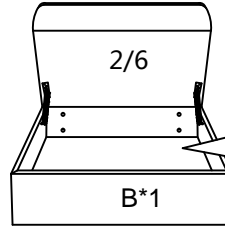

STEP 3

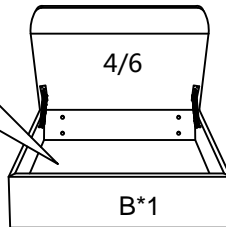
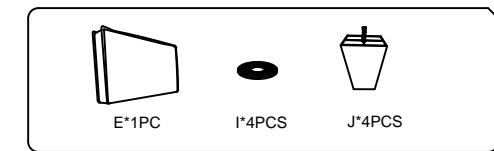
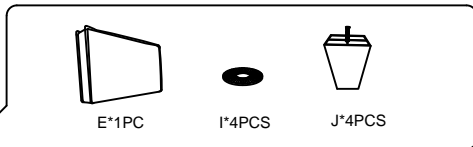
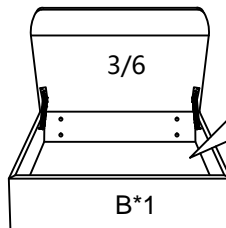

STEP 4

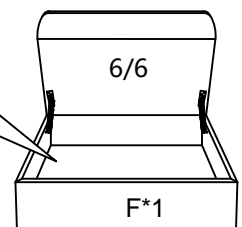
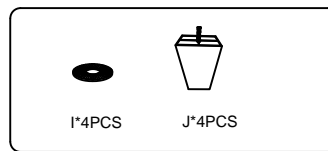
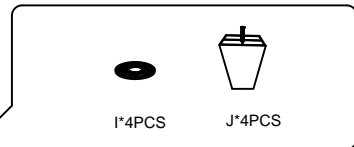
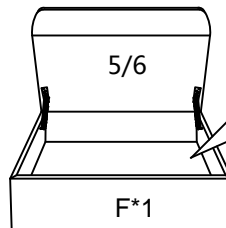

STEP 5

Screw into back about 2cm

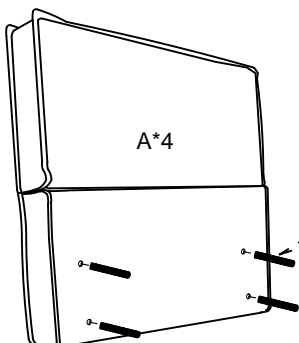

STEP 6

Insert the back with screws into the seat frame

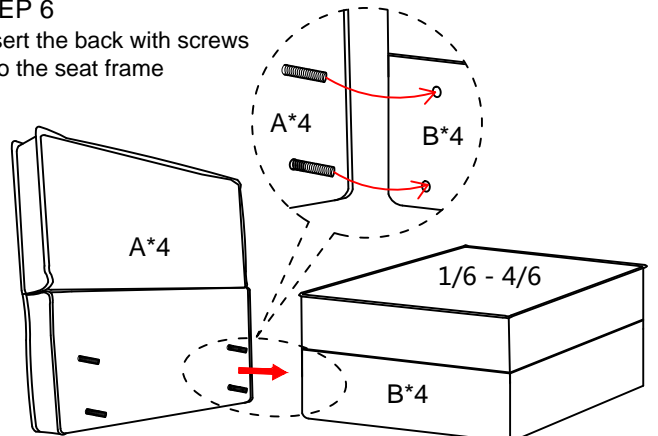

STEP 7

Put the washers, tighten the nuts with wrench from inside

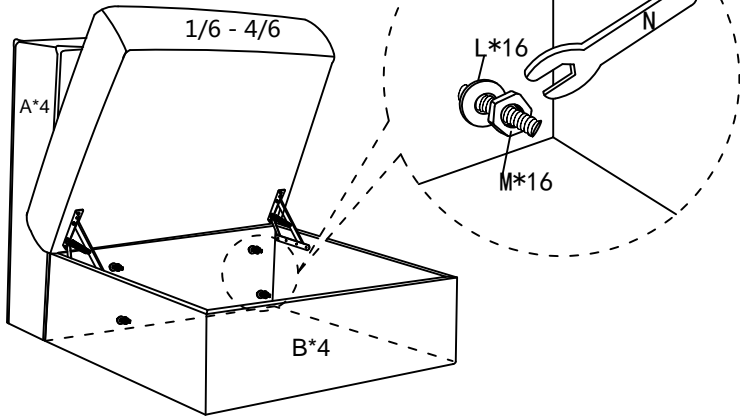

STEP 8

Backs with 5 angles for adjustable

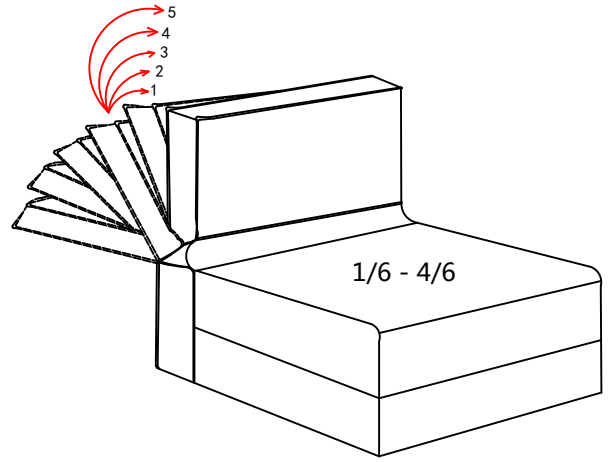

STEP 9

Assemble the hook "G" on arm "C"

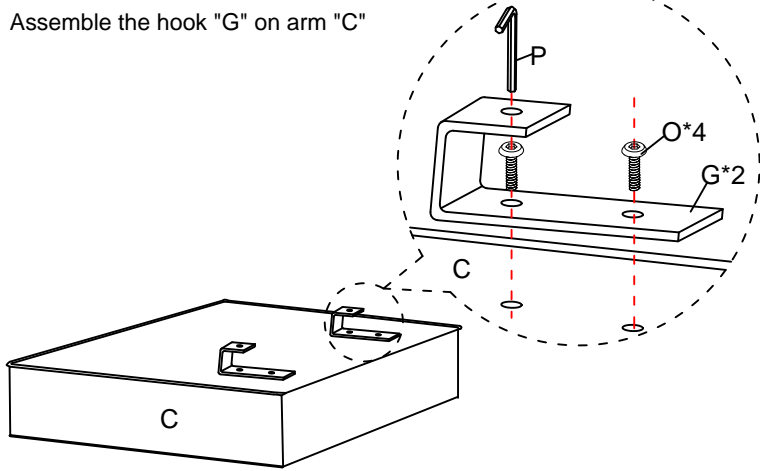

STEP 10

Hook the arm to the seat frame

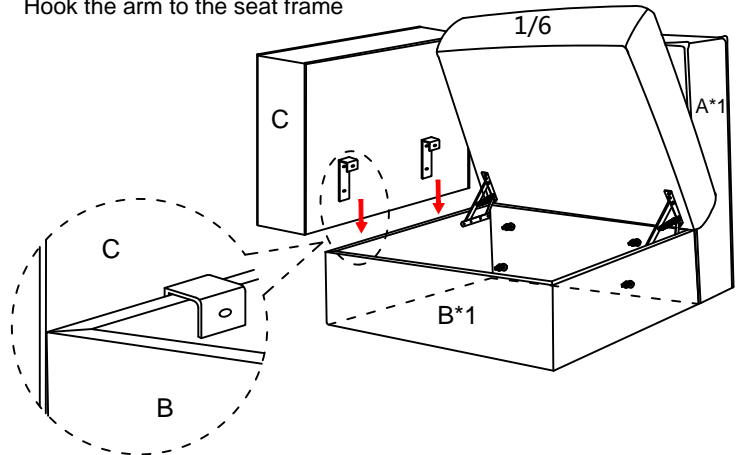

STEP 11

Assemble the hinge from the bottom to connect the arm "C" and the left seat frame

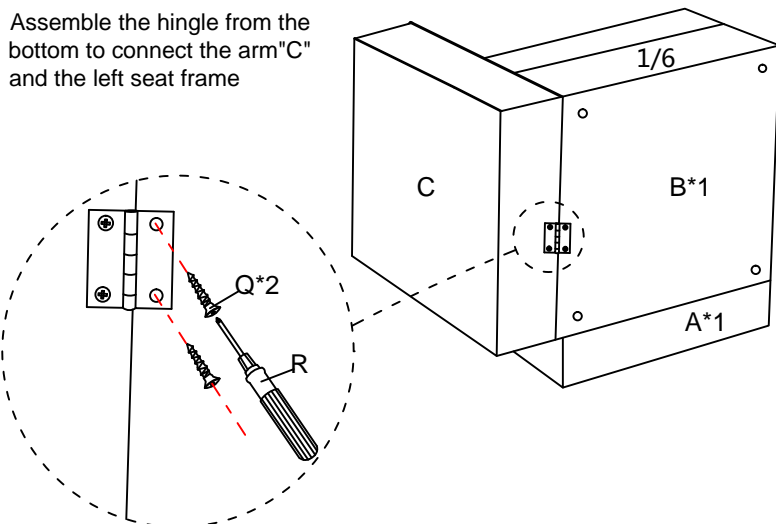

STEP 12

Assemble the legs

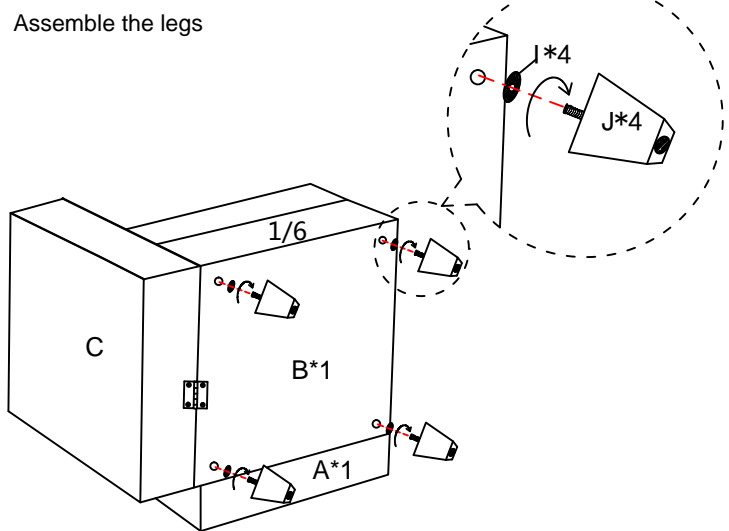

STEP 13

Assemble the hook "G" on arm "D"

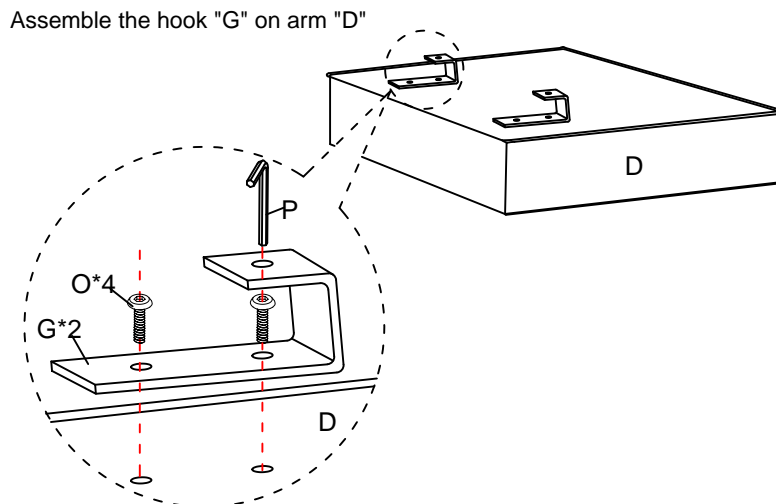

STEP 14

Hook the arm to the seat frame

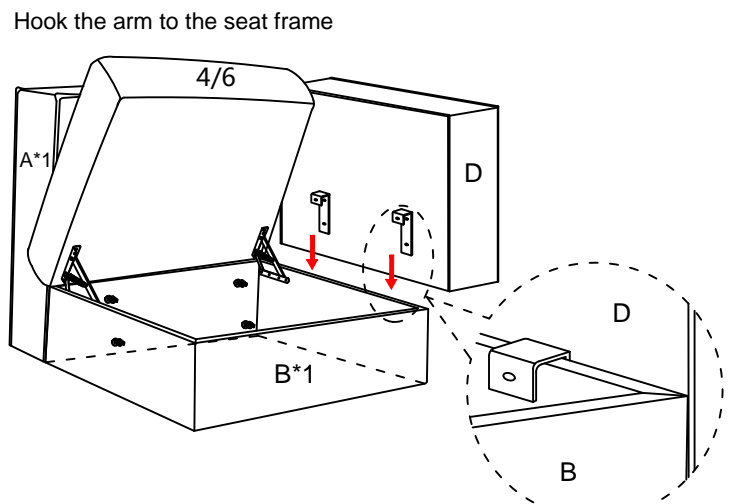

STEP 15

Assemble the hinge from the bottom to connect the arm "D" and the right seat frame

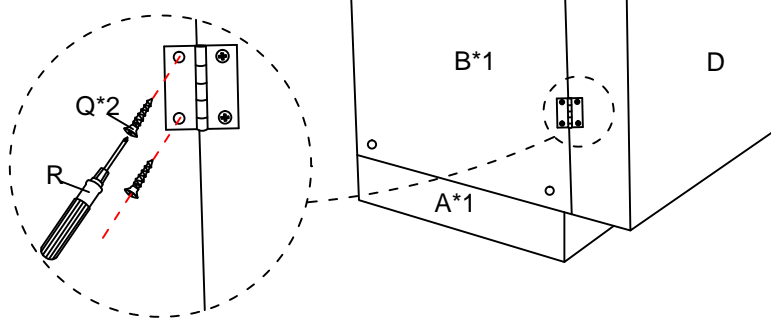

STEP 16

Assemble the legs

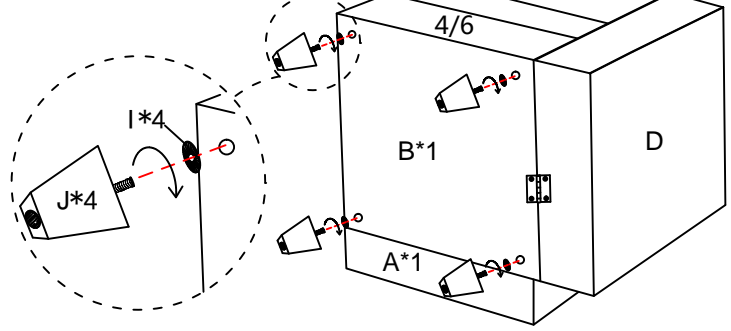

STEP 17

Assemble the legs

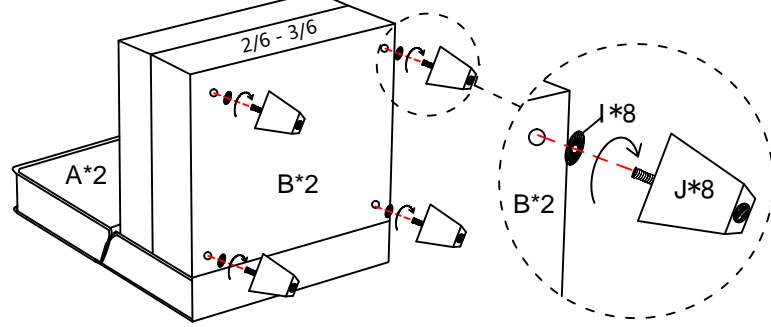

STEP 18

Assemble the legs

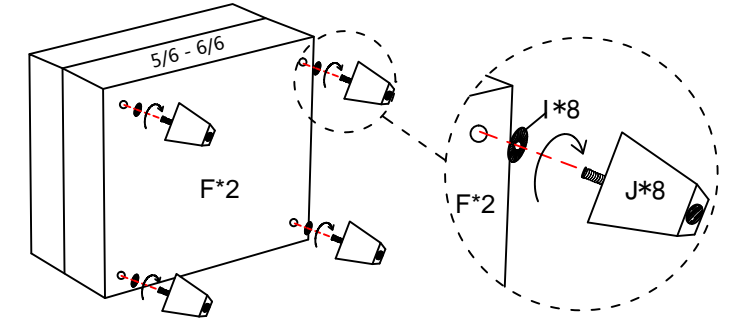

STEP 19

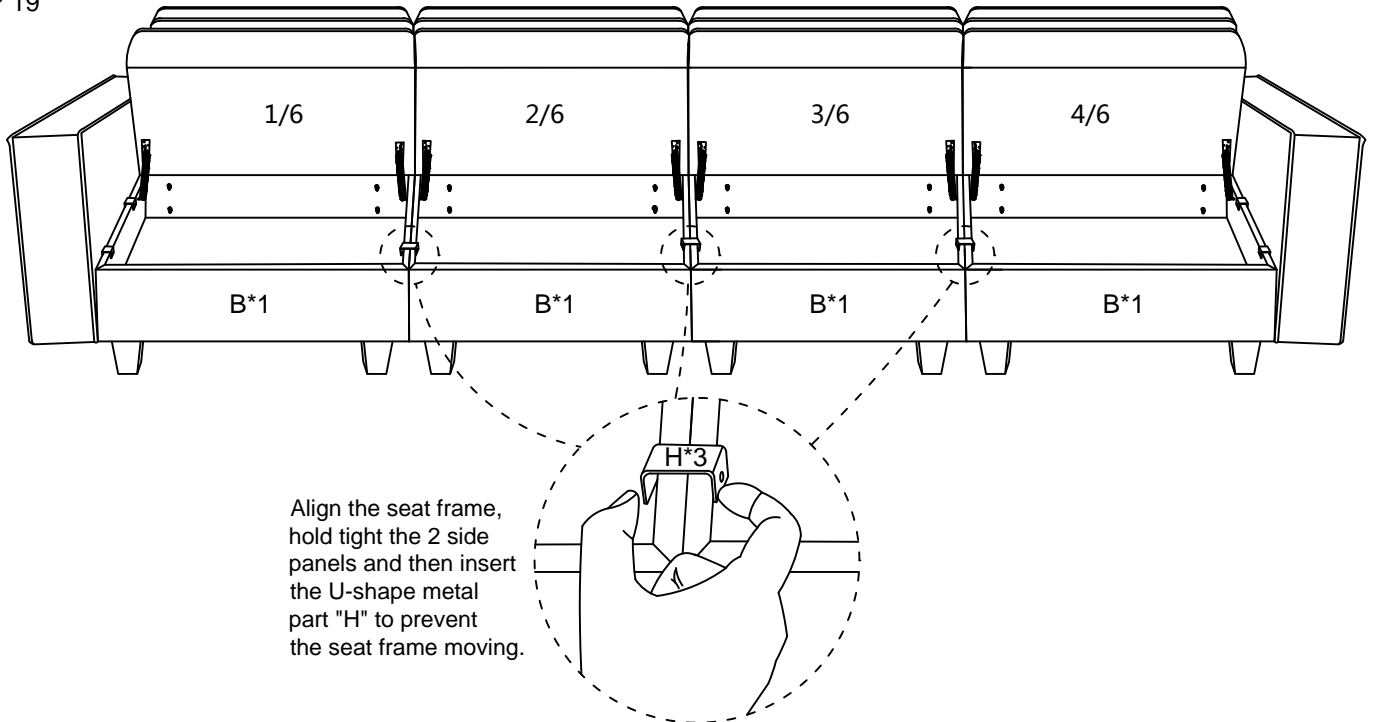

STEP 20

Put the back cushions on sofa and the assembly is finished

