

ASSEMBLY INSTRUCTIONS

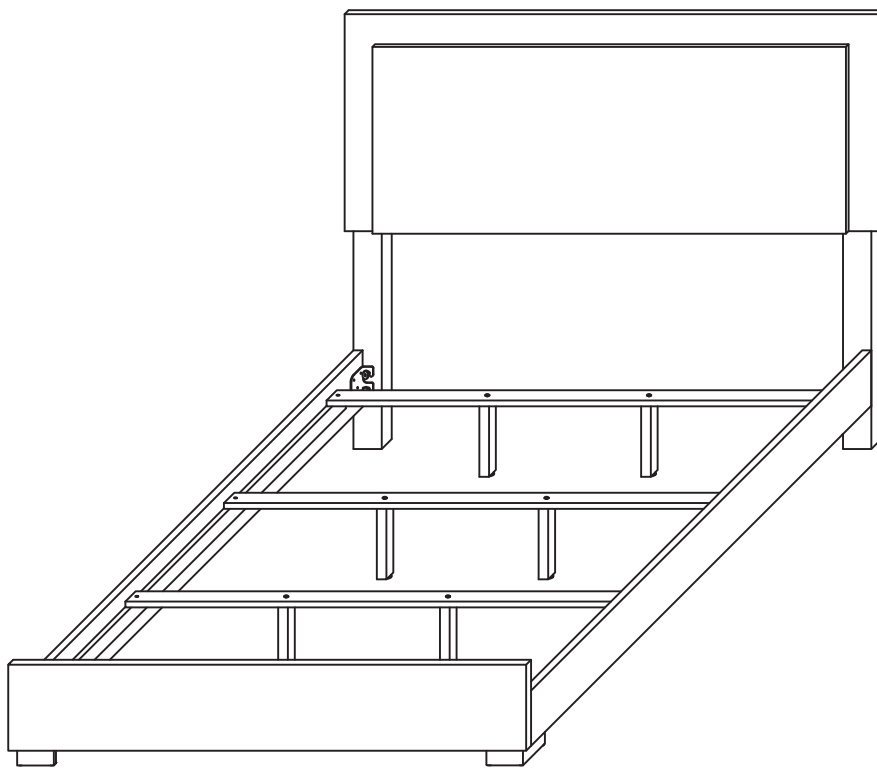

Fine Furniture for every stage of life

Eastern King Bed

REVISION 0 : 07/21/2023
REVISION 1 : 03/19/2025

ASSEMBLY INSTRUCTIONS

ASSEMBLY TIPS:

1. Remove hardware from box and sort by size.
2. Please check to see that all hardware and parts are present prior to start of assembly.
3. Please follow attached instructions in the same sequence as numbered to assure fast & easy assembly.



WARNING!

1. Don't attempt to repair or modify parts that are broken or defective. Please contact the store immediately.
2. This product is for home use only and not intended for commercial establishments.



ASSEMBLY TIME

30 MINUTES

PARTS IDENTIFICATION

B1 (BOX 1)

A HEADBOARD PANEL

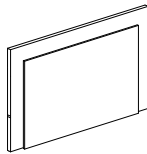

1PC

B LEFT HEADBOARD LEG (WITH "L" LABEL)

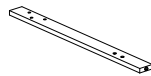

1PC

C RIGHT HEADBOARD LEG (WITH "R" LABEL)



1PC

D FOOTBOARD PANEL

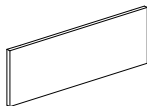

1PC

E METAL LEG



2PCS

F BED SLAT

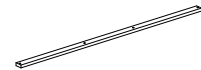

4PCS

G BED SLAT SUPPORT WITH LEVELER

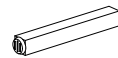

8PCS

H WOOD CLEAT



2PCS

J ADAPTER PLUG



1PC

B2 (BOX 2)

I BED RAIL

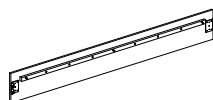

2PCS

ASSEMBLY INSTRUCTIONS

ASSEMBLY TIPS:

1. Remove hardware from box and sort by size.
2. Please check to see that all hardware and parts are present prior to start of assembly.
3. Please follow attached instructions in the same sequence as numbered to assure fast & easy assembly.











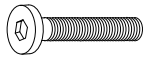

WARNING!

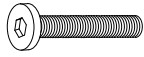
1. Don't attempt to repair or modify parts that are broken or defective. Please contact the store immediately.
2. This product is for home use only and not intended for commercial establishments.

HARDWARE IDENTIFICATION

BOX 1 - HARDWARE

1	BOLT 1 (M8 x 16MM - RBW)		8PCS	6	FLAT HEAD SCREW (M4 x 32MM - RBW)		8PCS
2	BOLT 2 (M8 x 35MM - RBW)		6PCS	7	SMALL ALLEN WRENCH (M4 x 65MM - BLK)		1PC
3	BOLT 3 (M6 x 35MM - RBW)		16PCS	8	BIG ALLEN WRENCH (M5 x 65MM - BLK)		1PC
4	BIG LOCK WASHER (5/16" x 14Ø - RBW)		6PCS	9	SMALL LOCK WASHER (1/4" x 12Ø - RBW)		8PCS
5	BIG FLAT WASHER (5/16" x 22Ø - RBW)		6PCS	10	SMALL FLAT WASHER (1/4" x 19Ø - RBW)		8PCS

NOTE:

Phillips head screw driver is required in the assembly process; however, manufacturer does not provided this item.

ASSEMBLY INSTRUCTIONS

STEP 1

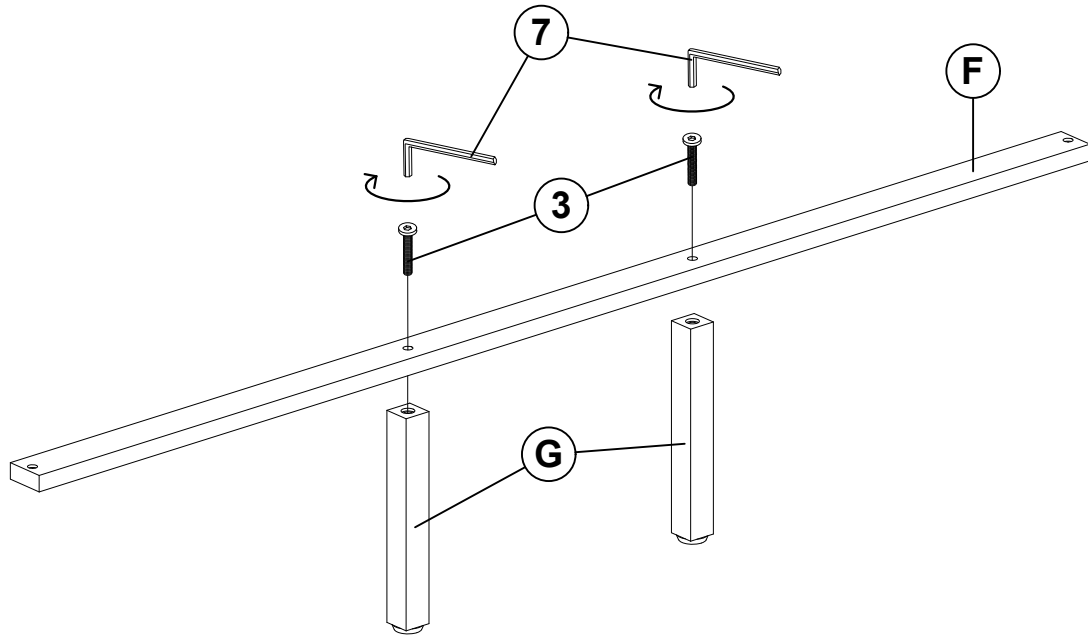

STEP 2

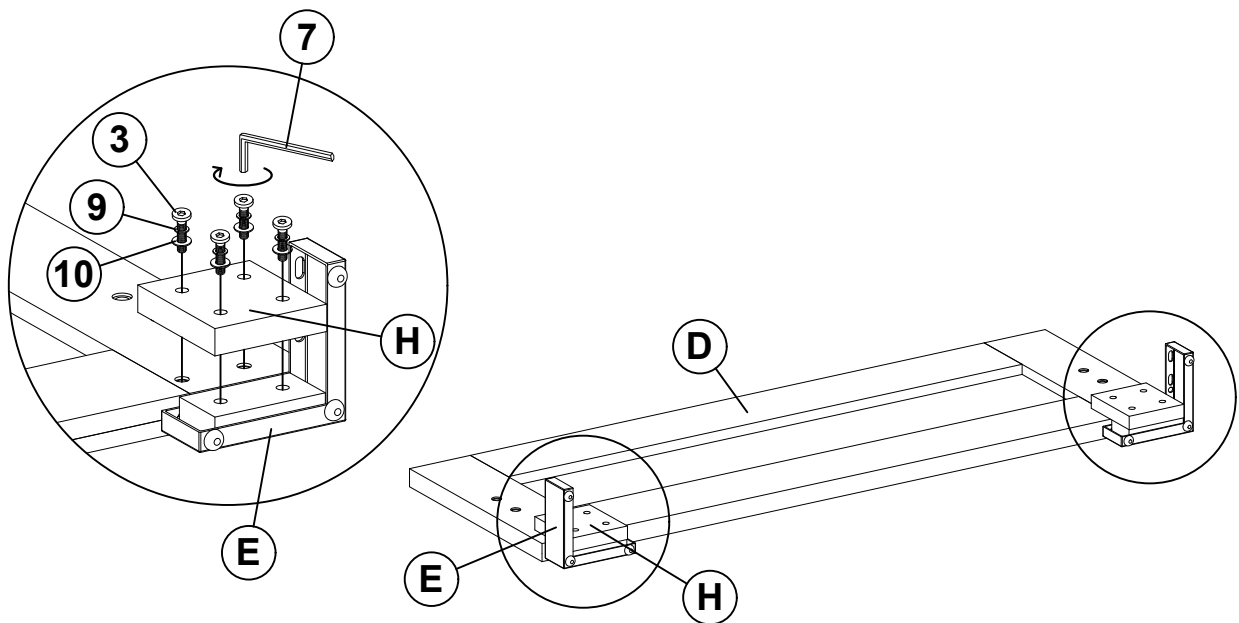

**** BACK VIEW**

ASSEMBLY INSTRUCTIONS

STEP 3

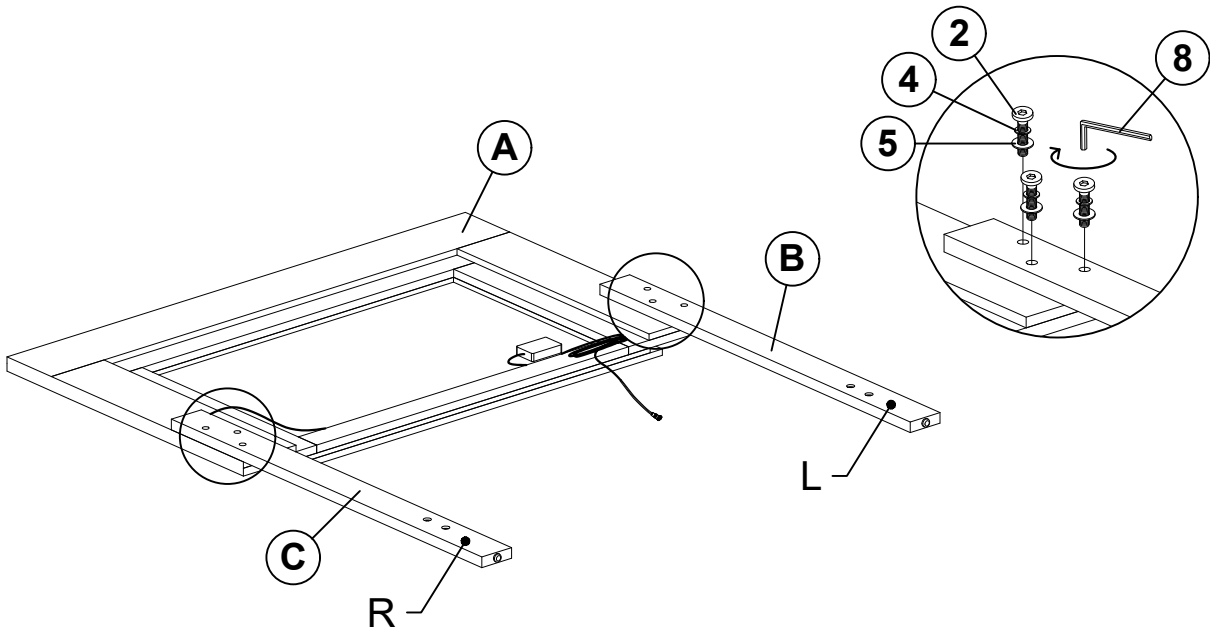

**** BACK VIEW**

STEP 4

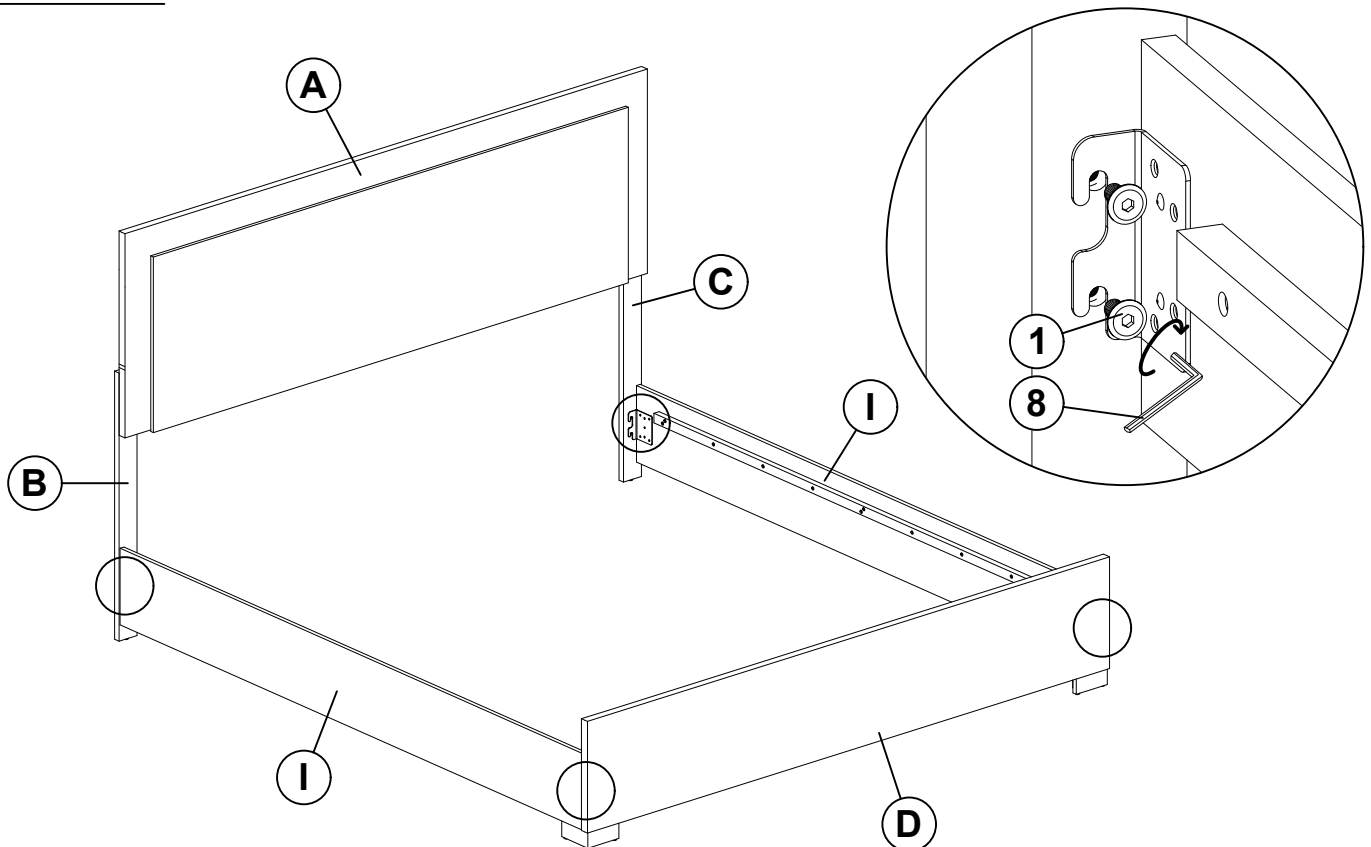

ASSEMBLY INSTRUCTIONS

STEP 5

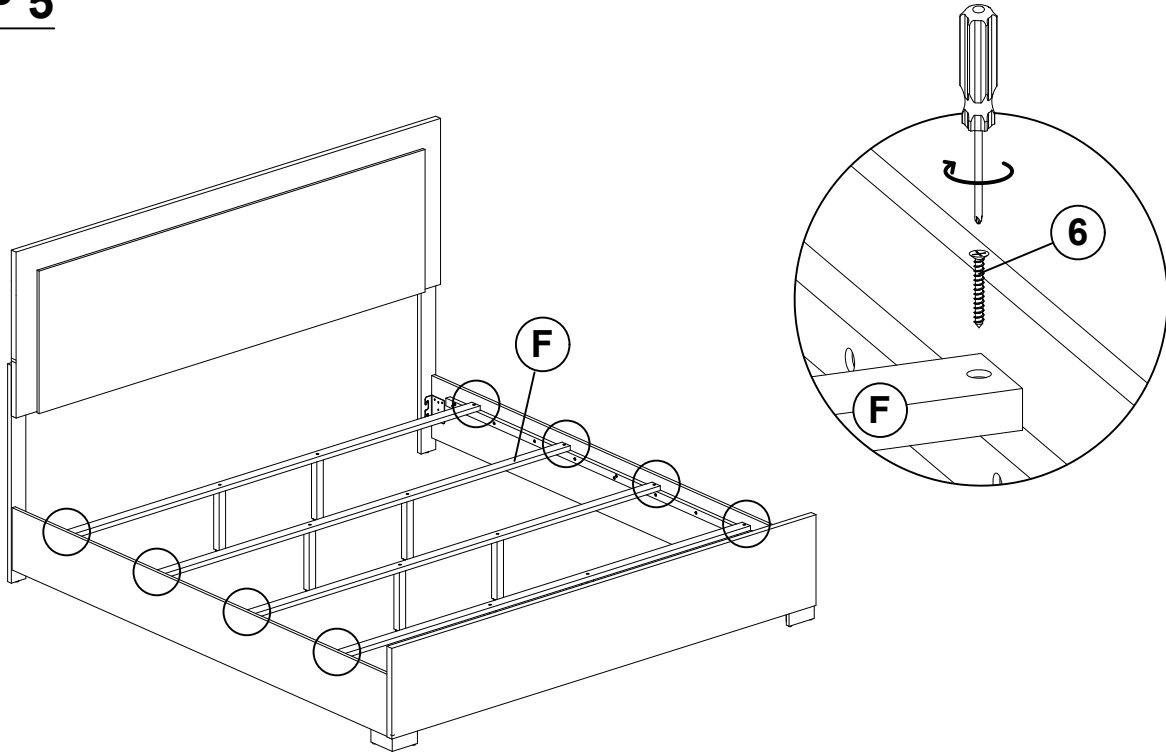

STEP 6 COMPLETE

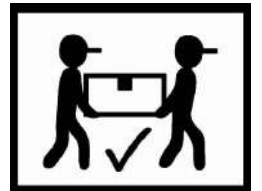
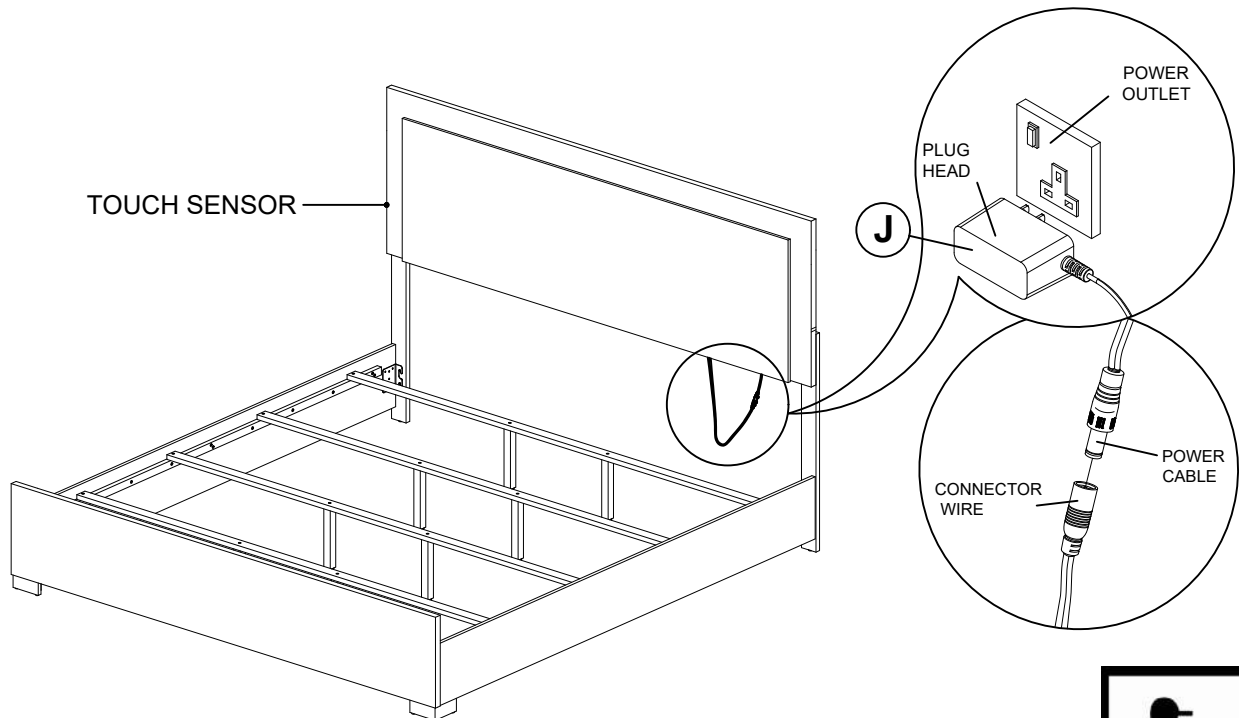

Inner Size : 76.50"W X 80.00"D

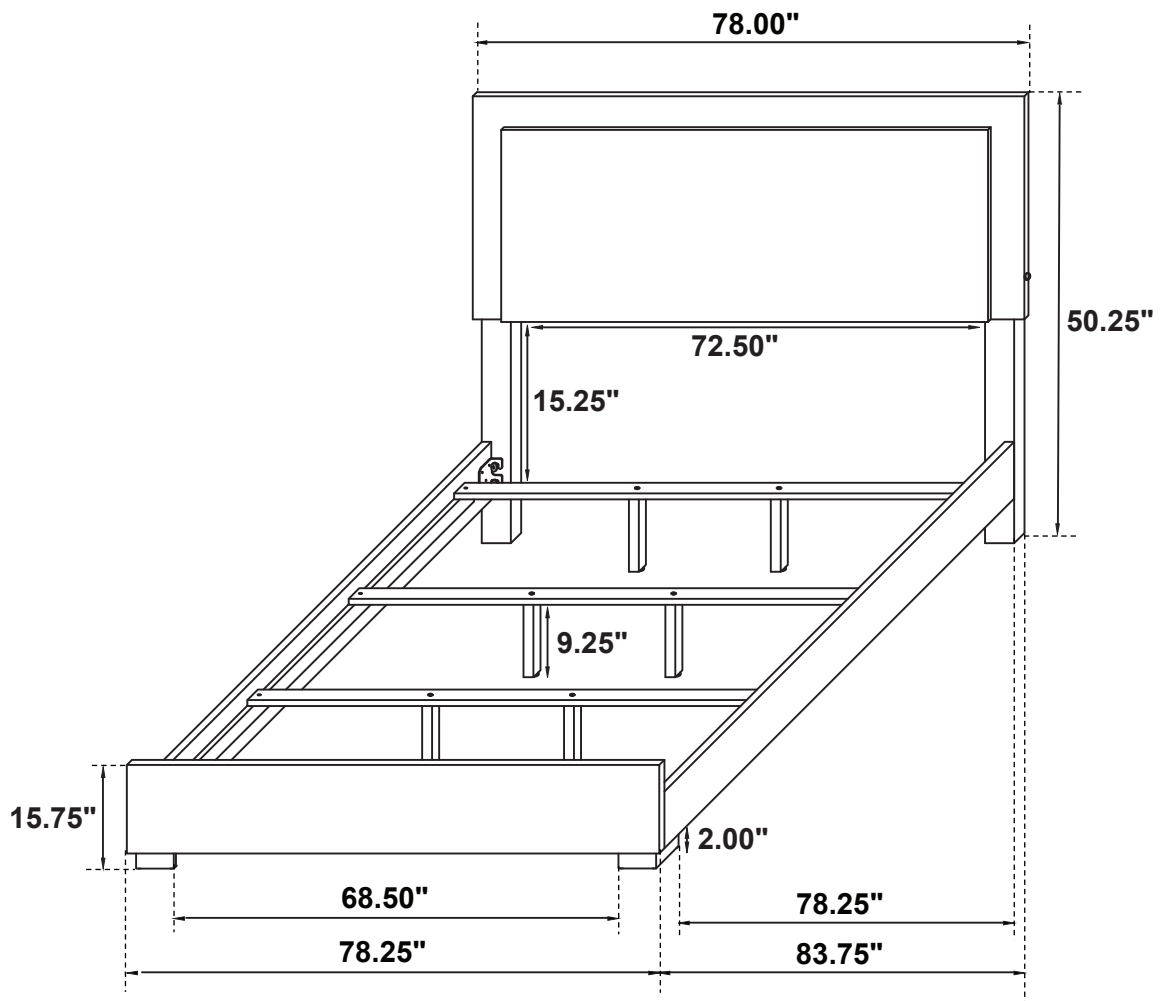

Note : Dimension tolerance $\pm 5\%$