

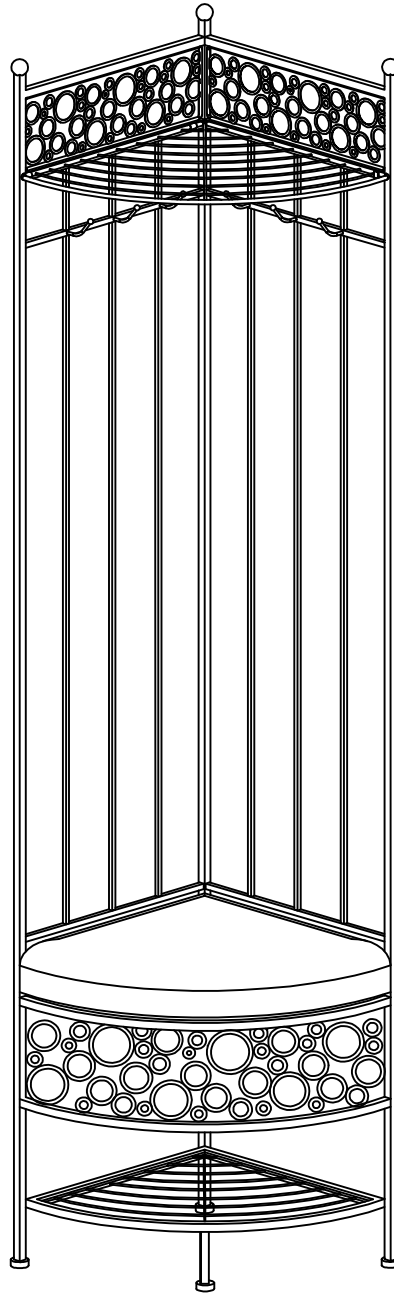

ASSEMBLY INSTRUCTIONS





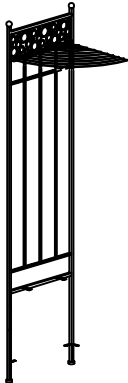
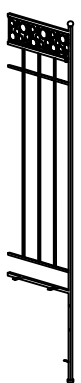

Style #M14 Corner Hallway Bench

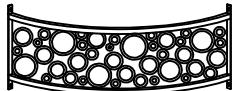
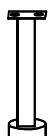
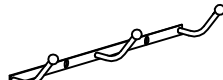
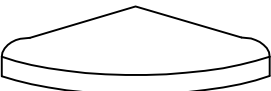

NOTE TO CUSTOMERS:

- For ease and speed of assembly we recommend that before you commence each step of the assembly that you identify all the parts required to complete that step.
- We recommend that where possible you allow sufficient space to assemble the item as close as possible to the place where it will be once assembled.
- For the protection of your furniture we recommend that the product is placed on protected surfaces during assembly to prevent any damage.
- During assembly do not over tighten, as this may damage the product.
- Please ensure you retain all the product packaging until the item completely assembled.
- Please periodically check all fittings and re-tighten as necessary.
- Never allow any liquid to remain on your furniture as absorption can cause the wood to warp or the finish to de-laminate.
- It is recommended that this item should be assembled by two adults.

<p>A1</p> <p>Quantity 1pc</p>  <p>Side Frame</p>	<p>A2</p> <p>Quantity 1pc</p>  <p>Side Frame</p>	<p>A3</p> <p>Quantity 1pc</p>  <p>Bottom Shelf Rack</p>	<p>A4</p> <p>Quantity 1pc</p>  <p>Apron</p>
<p>A5</p> <p>Quantity 1pc</p>  <p>Support Leg</p>	<p>A6</p> <p>Quantity 2pcs</p>  <p>Hook Rack</p>	<p>A7</p> <p>Quantity 1pc</p>  <p>Seat</p>	

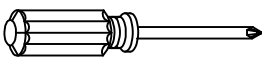
<p>B1</p> <p>Quantity 5pcs</p>  <p>Bolt</p>	<p>B2</p> <p>Quantity 16pcs</p>  <p>Bolt</p>	<p>B3</p> <p>Quantity 4pcs</p>  <p>Screw</p>	<p>B4</p> <p>Quantity 2pcs</p>  <p>Screw</p>
<p>B5</p> <p>Quantity 2pcs</p>  <p>Plastic Anchor</p>	<p>B6</p> <p>Quantity 1pc</p>  <p>Allen Wrench</p>	<p>Tool Required:</p>  <p>Phillip Screwdriver(Not included)</p>	

STEP 1

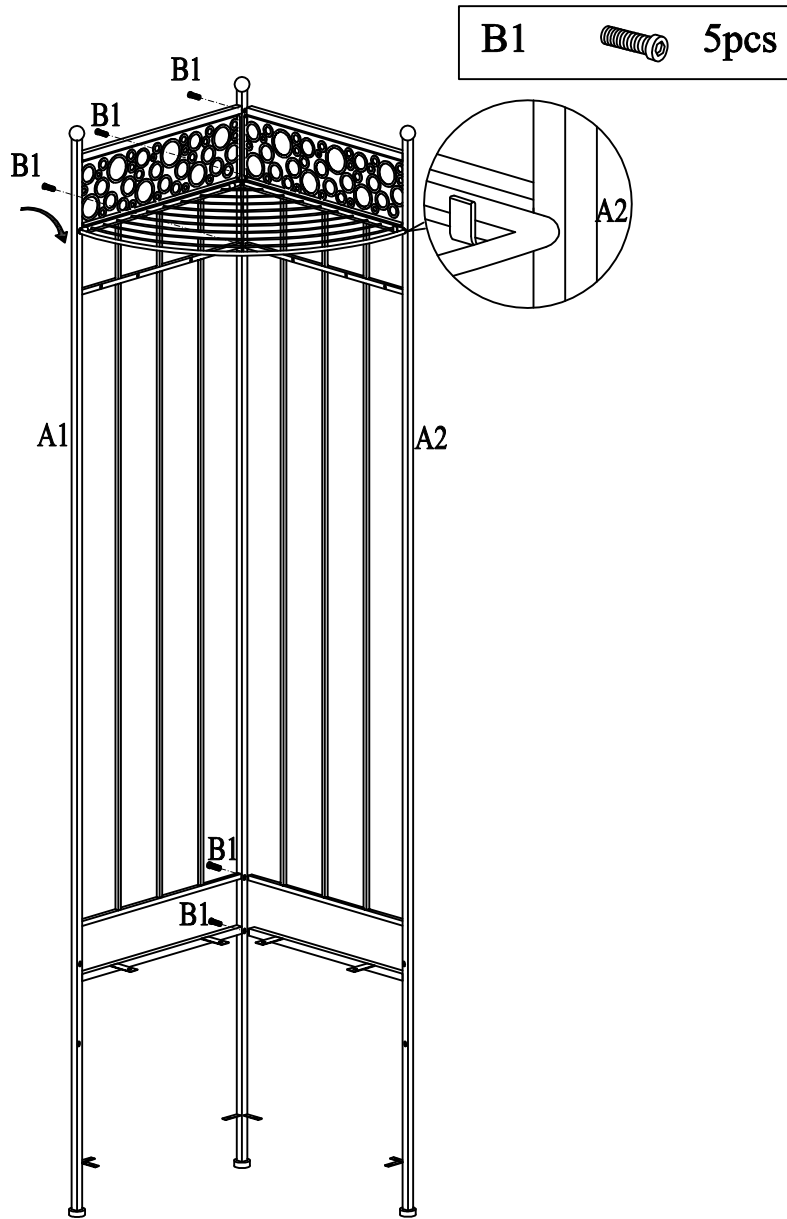

Assemble Side Frame A1 to Side Frame A2 using bolts B1, then place the upper net rack onto Side Frame A2. Do not tighten bolts until step 5.

STEP 2

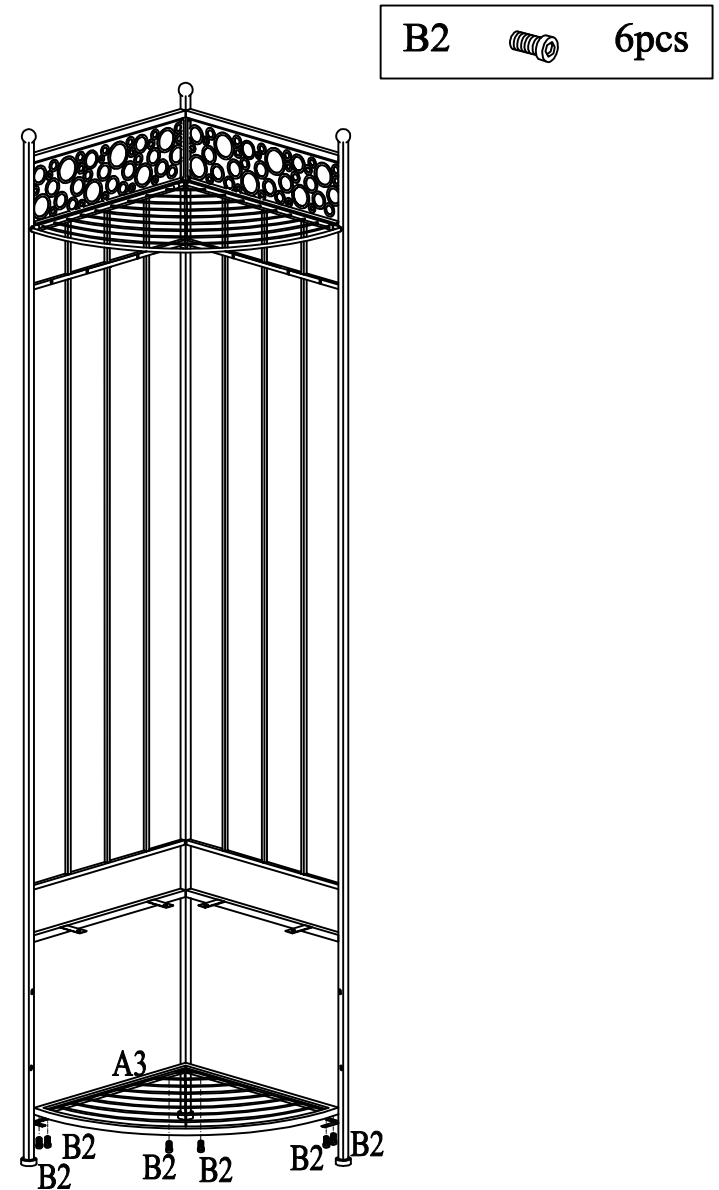

Assemble Bottom Shelf A3 to Side Frames A2 & A1 using Bolts B2. Do not tighten bolts until step 5.

STEP 3

B2  6pcs

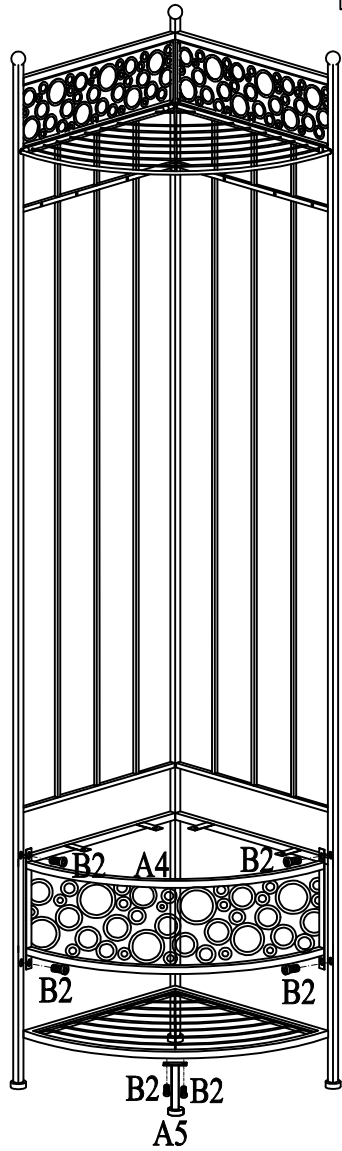

- 1). Assemble Apron A4 to Side Frames A2 & A1 using Bolts B2.
- 2). Then assemble Support Leg A5 to Bottom Shelf A3 using Bolts B2.
Do not tighten bolts until step 5.

STEP 4

B2  4pcs

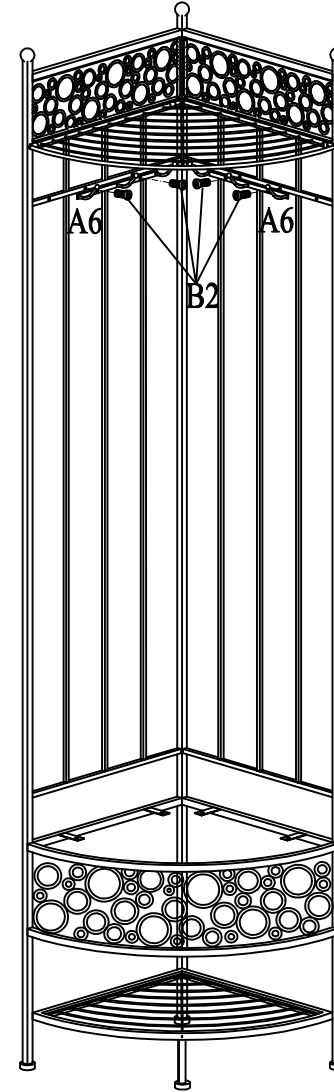

Assemble Hook Racks A6 to Side Frames A2 & A1 using Bolts B2.

STEP 5

B3  4pcs

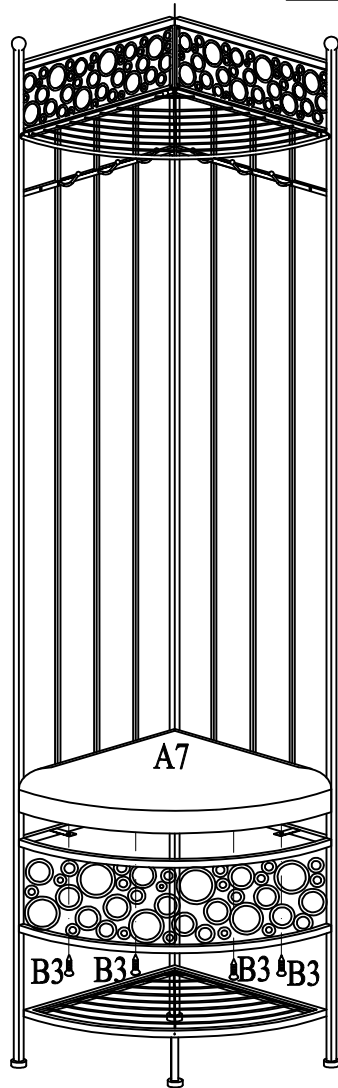

Please tighten all bolts at this point, then attach Seat A7 using Screws B3.

STEP 6

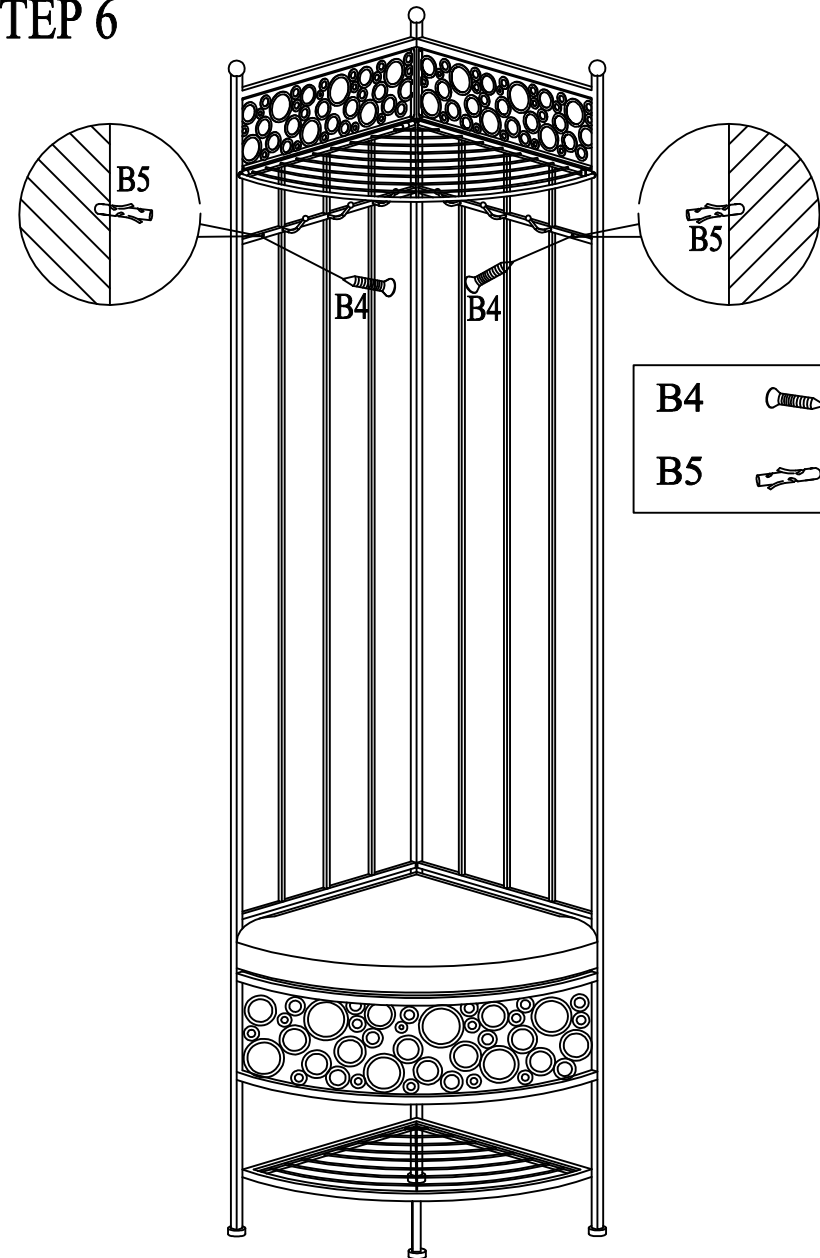

B4  2pcs

B5  2pcs

For your safety, please attach this unit to the wall by Plastic Anchors B5 and Screws B4 as shown above. The weight capacity of this unit is 250 LBS.

APPENDIX: Dimension of Hardwares in this AI.

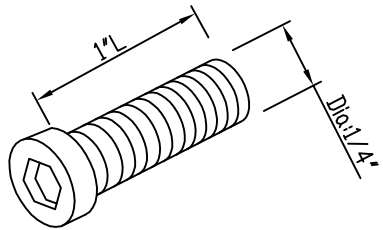
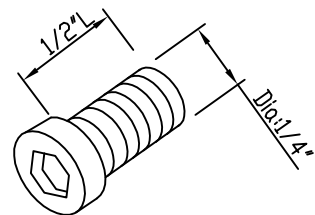
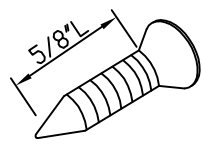
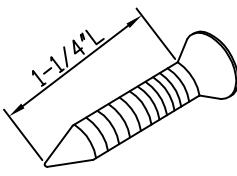
<p>B1.</p>  <p>Bolt</p>	<p>B2.</p>  <p>Bolt</p>
<p>B3.</p>  <p>Bolt</p>	<p>B4.</p>  <p>Bolt</p>