



# ASSEMBLY INSTRUCTIONS

MODEL:

B1862-311W - HAWTHORNE 5/0 QUEEN WHITE UPHOLSTERED  
PLATFORM HEADBOARD-WALNUT

B1862-311G - HAWTHORNE 5/0 QUEEN CHARCOAL UPHOLSTERED  
PLATFORM HEADBOARD-WALNUT

B1862-330 - 1862 PLATFORM BEDS

Thank you for purchasing this quality product. Be sure to check all packing materials carefully for small parts, which may have come loose inside the carton during shipment. Identify and count all items and compare with the parts list and/or hardware list shown below.

Please read all instructions carefully. See the hardware and furniture part listing for guidance. Be sure you have all parts listed before beginning assembly. Place all wooden parts on a clean, flat surface to protect the finish from scratches. Follow the diagram to assemble.

**CAUTION**

1. Do not fully tighten the nuts or bolts until the table is fully assembled.
2. Please tighten by hand, not by a drill. Overtightening will damage threads. Do not overtighten.
3. Keep all hardware out of the reach of children.

PARTS LIST				PARTS LIST			
ITEM	DESCRIPTION	SKETCH	QTY	ITEM	DESCRIPTION	SKETCH	QTY
BOX 1 PARTS LIST				BOX 2 PARTS LIST			
A	HEADBOARD		1 PC	D	FOOTBOARD LEG (L)		1 PC
B	HEADBOARD LEG (L)		1 PC	E	FOOTBOARD LEG (R)		1 PC
C	HEADBOARD LEG (R)		1 PC	F	PANEL		2 PCS
				G	SIDE RAIL		2 PCS
				H	SLAT SUPPORT		1 PC
				I	CENTER SUPPORT		3 PCS
				J	SLAT		2 SET

WEIGHT CAPACITY	600 LBS
-----------------	---------

HARDWARE DIMENSIONS  
VERIFICATION TOOL

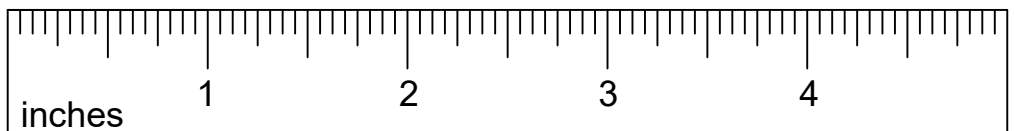

# ASSEMBLY INSTRUCTIONS

MODEL:

B1862-311W - HAWTHORNE 5/0 QUEEN WHITE UPHOLSTERED  
PLATFORM HEADBOARD-WALNUT

B1862-311G - HAWTHORNE 5/0 QUEEN CHARCOAL UPHOLSTERED  
PLATFORM HEADBOARD-WALNUT















B1862-330 - 1862 PLATFORM BEDS

Thank you for purchasing this quality product. Be sure to check all packing materials carefully for small parts, which may have come loose inside the carton during shipment. Identify and count all items and compare with the parts list and/or hardware list shown below.

Please read all instructions carefully. See the hardware and furniture part listing for guidance. Be sure you have all parts listed before beginning assembly. Place all wooden parts on a clean, flat surface to protect the finish from scratches. Follow the diagram to assemble.

### CAUTION

1. Do not fully tighten the nuts or bolts until the table is fully assembled.
2. Please tighten by hand, not by a drill. Overtightening will damage threads. Do not overtighten.
3. Keep all hardware out of the reach of children.

HARDWARE LIST (BOX 1)				HARDWARE LIST (BOX 1)			
ITEM	DESCRIPTION	SKETCH	QTY	ITEM	DESCRIPTION	SKETCH	QTY
1	BOLT M6 x 2 3/8"		4 PCS	10	M4 ALLEN KEY		1 PC
2	BOLT M8 x 1 6/10"		3 PCS	11	SPANNER 10 MM ( M6 )		1 PC
3	BOLT M6 x 6/10"		4 PCS	12	FLAT WASHER M6 x 7/9"		4 PCS
4	WOOD DOWEL Ø8 x 1 1/5"		2 PCS	13	SPRING WASHER M6 x 7/15"		4 PCS
5	CSK SCREW M4 x 1"		8 PCS	14	SUPPORT LEG ADJUSTABLE FEET		3 PCS
6	STUD BOLT M6 x 2 3/8"		16 PCS	15	SMALL WOODEN BLOCK		4 PCS
7	HEX NUT M6		16 PCS				
8	BEND WASHER Ø7.5		16 PCS				
9	BEND WASHER 3013		16 PCS				

WEIGHT CAPACITY	600 LBS
-----------------	---------

HARDWARE DIMENSIONS  
VERIFICATION TOOL

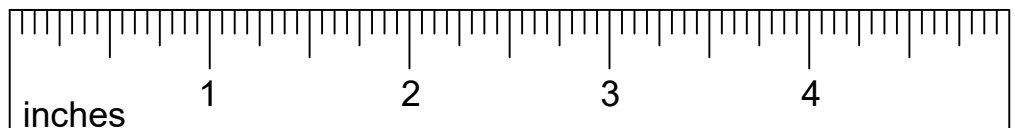

# ASSEMBLY INSTRUCTIONS

MODEL:

B1862-311W - HAWTHORNE 5/0 QUEEN WHITE UPHOLSTERED PLATFORM HEADBOARD-WALNUT

B1862-311G - HAWTHORNE 5/0 QUEEN CHARCOAL UPHOLSTERED PLATFORM HEADBOARD-WALNUT

B1862-330 - 1862 PLATFORM BEDS

**STEP 1: INSERT WOODEN (4) TO (B)&(C) THEN INSERT ALL (6) TO (B),(C),(D),(E)**

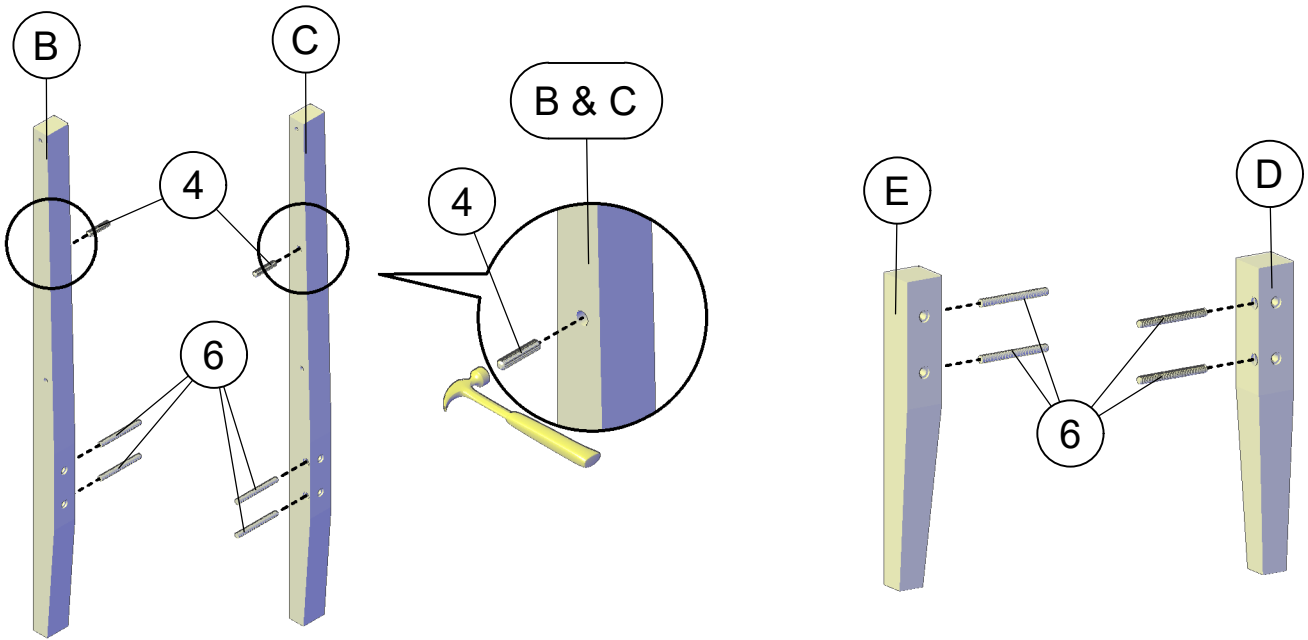

**STEP 2: TIGHTEN 1 USING 10, TIGHTEN 7 USING 11. INSERTING THE 15 SMALL WOODEN BLOCK INTO HOLES B AND C**

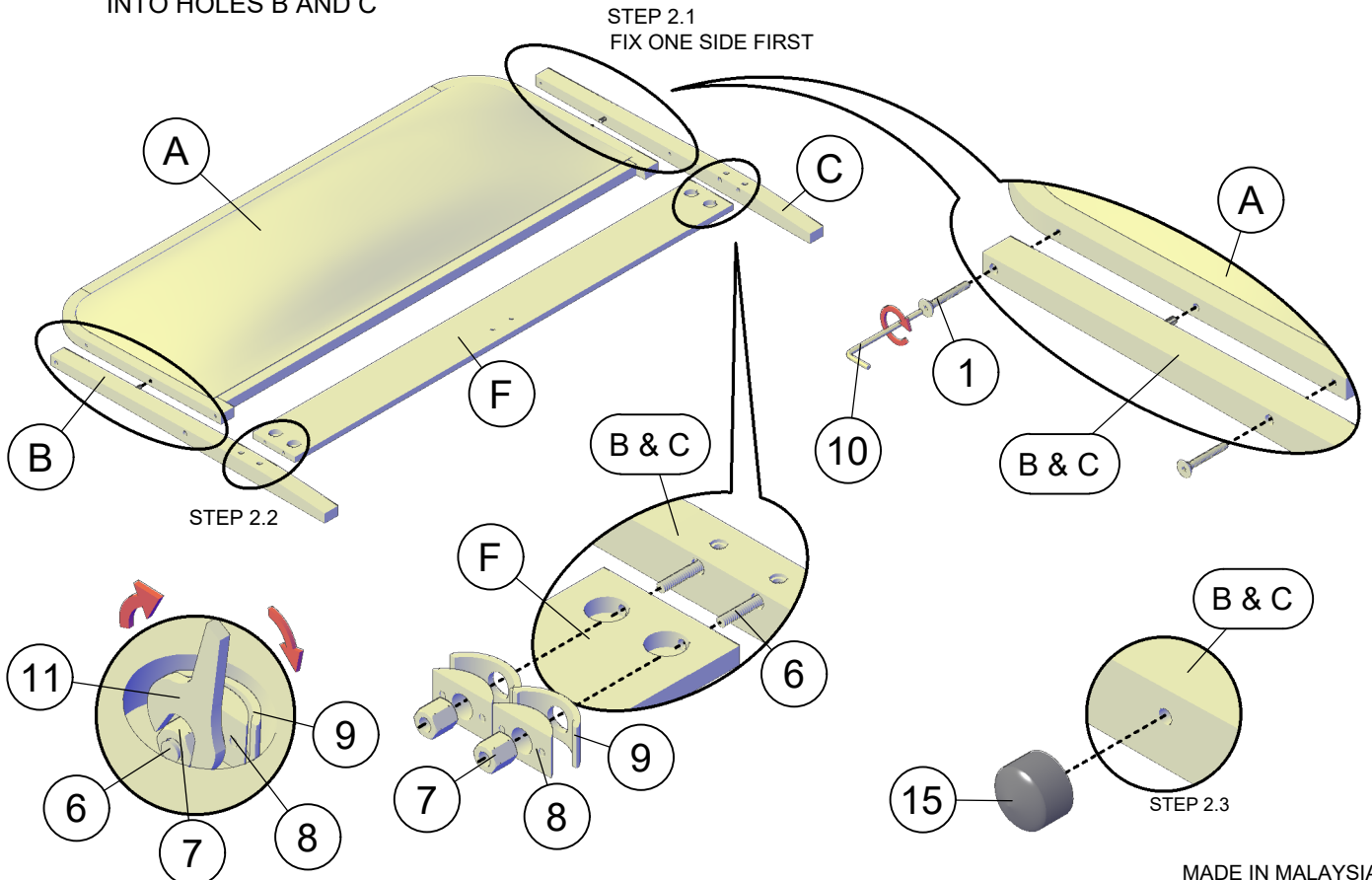

# ASSEMBLY INSTRUCTIONS

MODEL:

B1862-311W - HAWTHORNE 5/0 QUEEN WHITE UPHOLSTERED PLATFORM HEADBOARD-WALNUT

B1862-311G - HAWTHORNE 5/0 QUEEN CHARCOAL UPHOLSTERED PLATFORM HEADBOARD-WALNUT

B1862-330 - 1862 PLATFORM BEDS

## STEP 3: ALIGN D & E TO F THEN USE 11 TIGHTEN 7

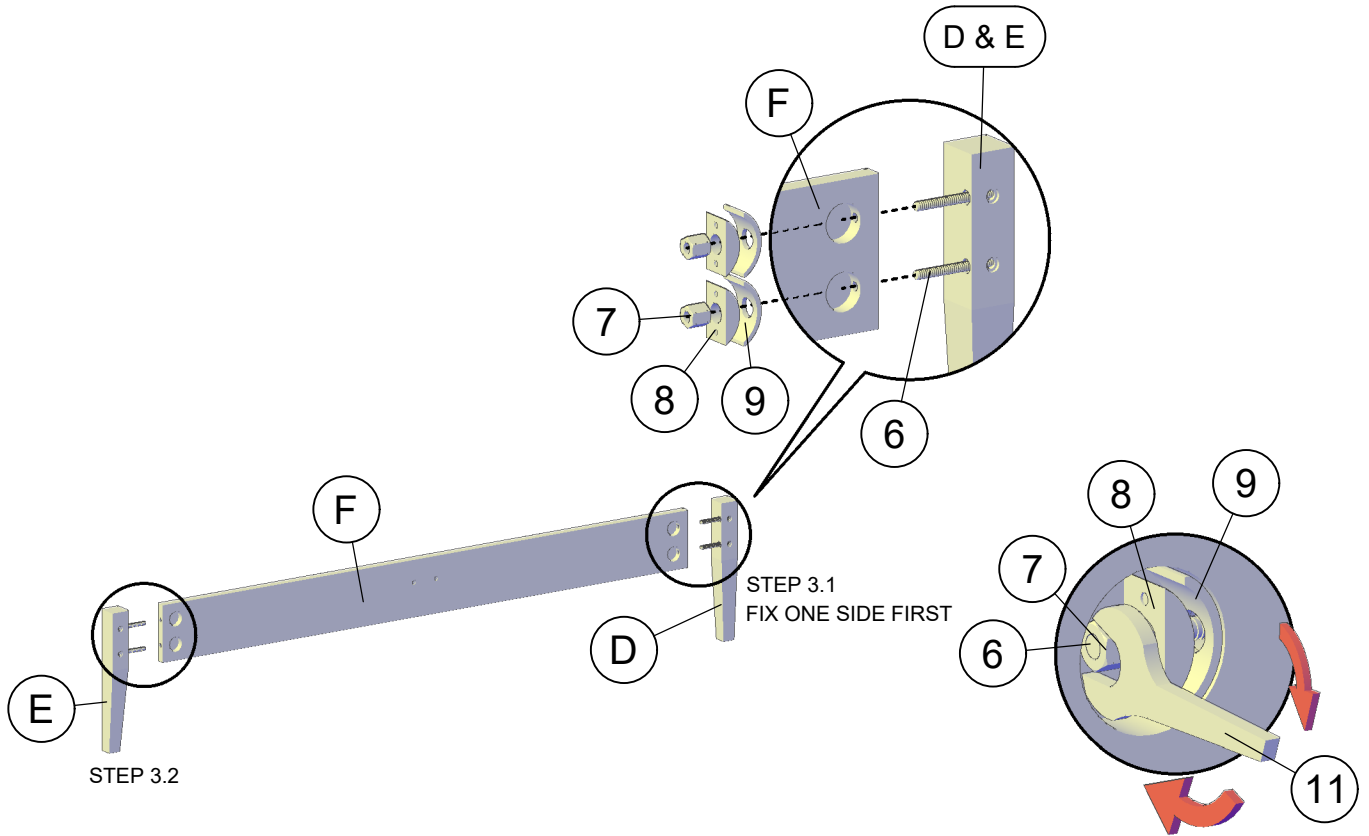

## STEP 4: INSERT 6 TO B & C

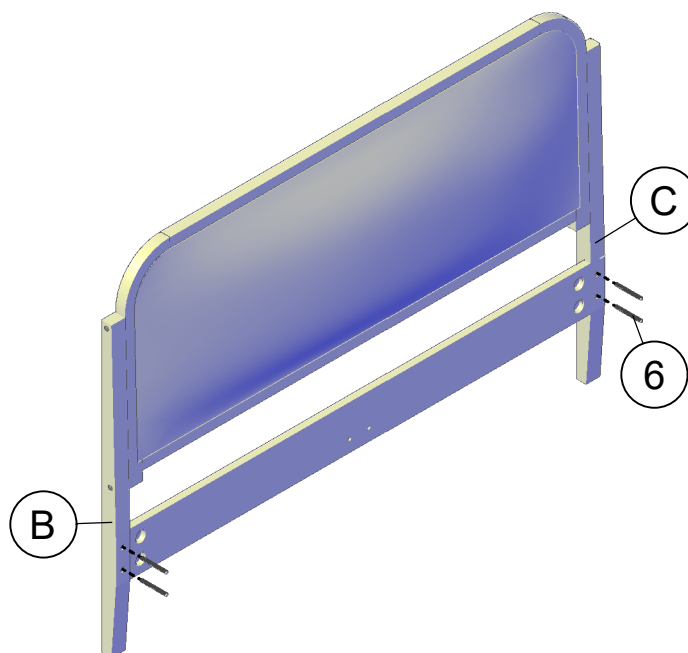

# ASSEMBLY INSTRUCTIONS

MODEL:

B1862-311W - HAWTHORNE 5/0 QUEEN WHITE UPHOLSTERED PLATFORM HEADBOARD-WALNUT

B1862-311G - HAWTHORNE 5/0 QUEEN CHARCOAL UPHOLSTERED PLATFORM HEADBOARD-WALNUT

B1862-330 - 1862 PLATFORM BEDS

**STEP 5: INSERT 6 to E AND D**

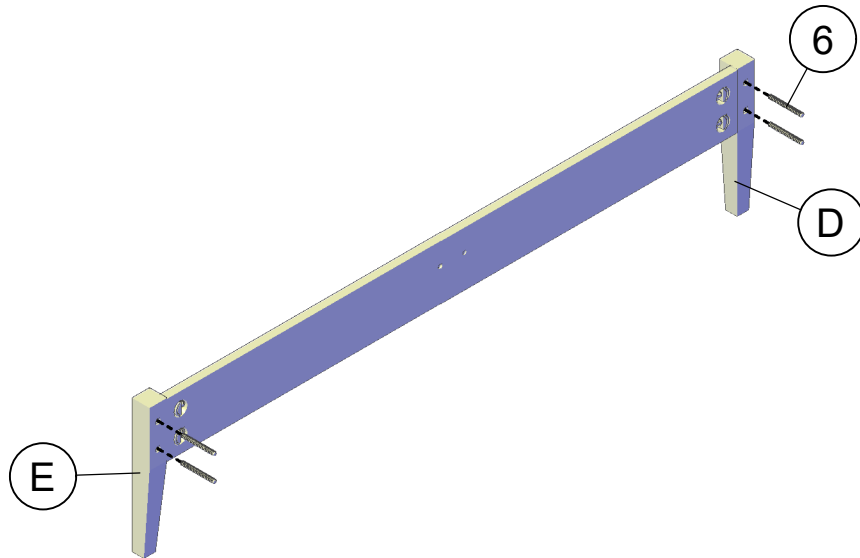

**STEP 6: INSERT G TO B-E THEN USING 11 TO TIGHTEN 7**

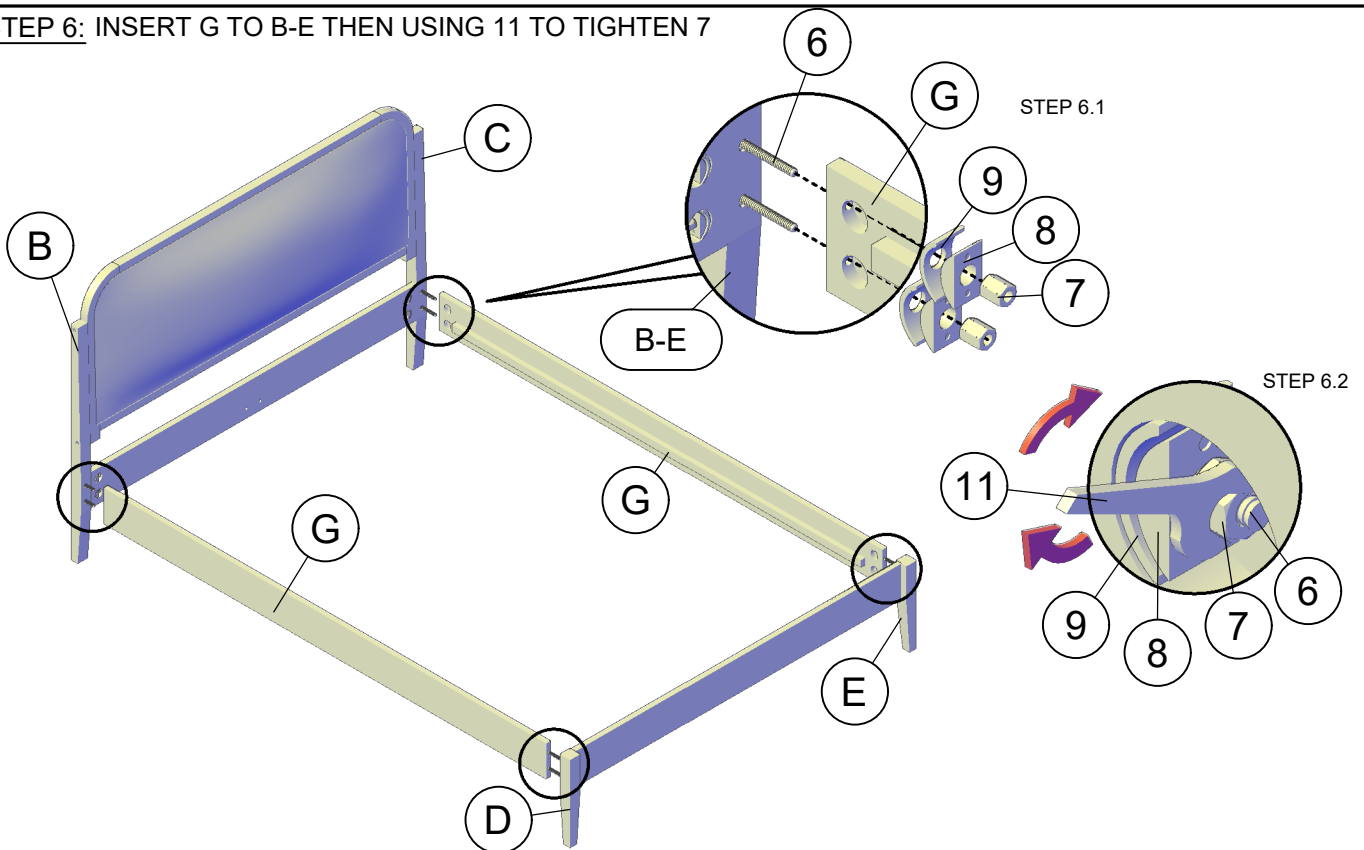

# ASSEMBLY INSTRUCTIONS

MODEL:

B1862-311W - HAWTHORNE 5/0 QUEEN WHITE UPHOLSTERED PLATFORM HEADBOARD-WALNUT

B1862-311G - HAWTHORNE 5/0 QUEEN CHARCOAL UPHOLSTERED PLATFORM HEADBOARD-WALNUT

B1862-330 - 1862 PLATFORM BEDS

**STEP 7:** ALIGN THE I WITH H, THEN USE TIGHTEN 2 USING 10

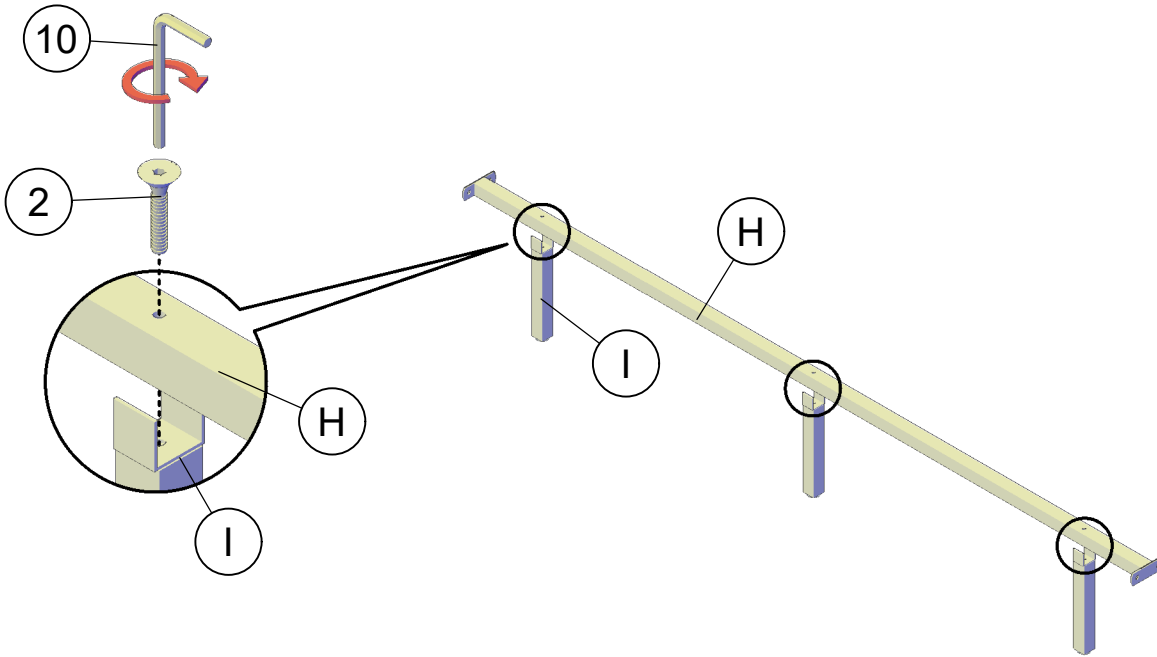

**STEP 8:** ALIGN THE H IN THE HOLE OF F, THEN USE IT TO INSTALL PARTS 12 AND 13 ONTO PART 3. AFTER THAT, TIGHTEN PART 3 USING PART 10.

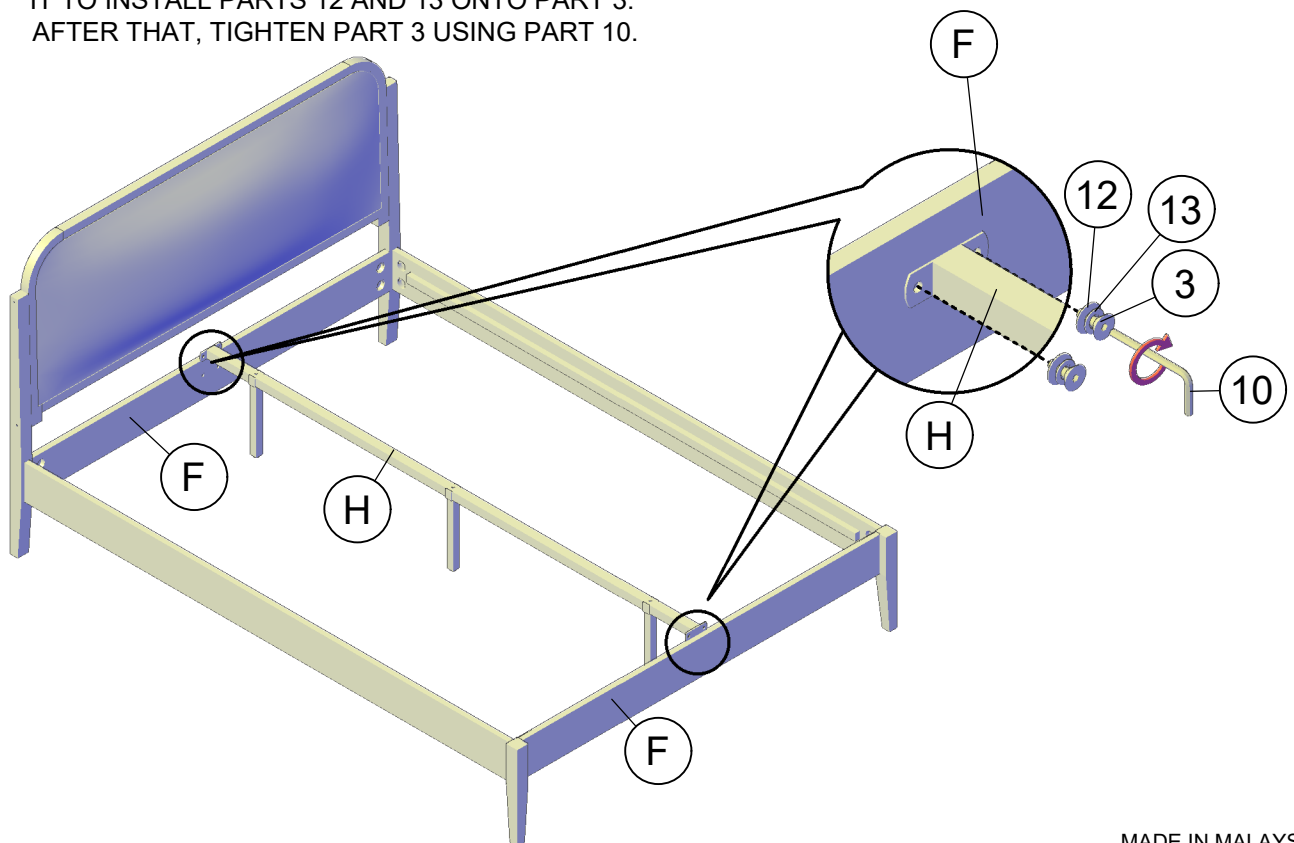

# ASSEMBLY INSTRUCTIONS

MODEL:

B1862-311W - HAWTHORNE 5/0 QUEEN WHITE UPHOLSTERED PLATFORM HEADBOARD-WALNUT

B1862-311G - HAWTHORNE 5/0 QUEEN CHARCOAL UPHOLSTERED PLATFORM HEADBOARD-WALNUT

B1862-330 - 1862 PLATFORM BEDS

**STEP 9:** PLACE J DOWN, THEN USE A SCREWDRIVER TO TIGHTEN 5.

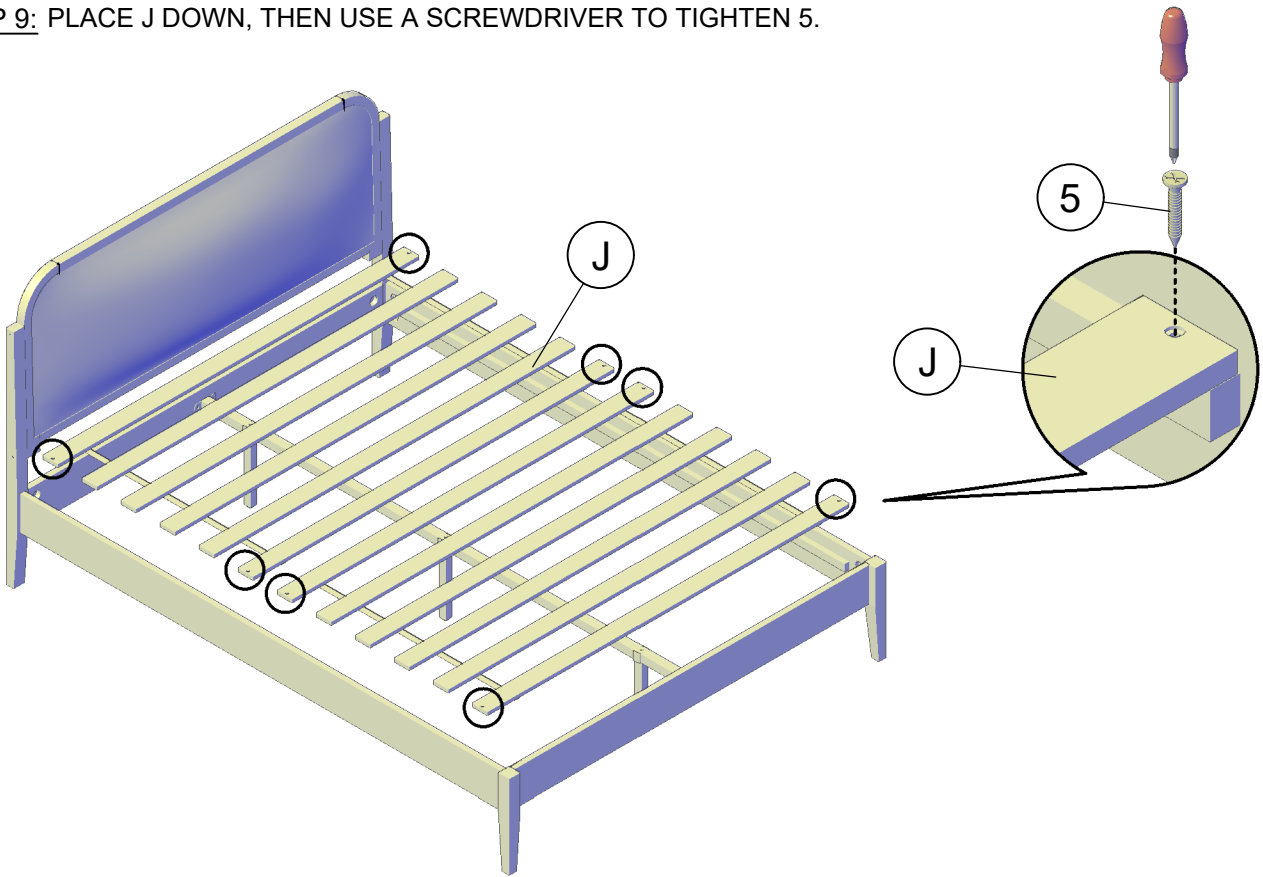

**ASSEMBLY COMPLETE**

