

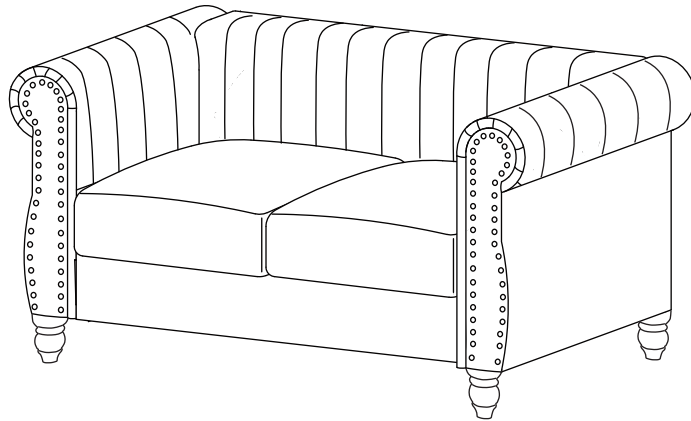



ASSEMBLY INSTRUCTIONS

WF306101/102/105

2 SEATER SOFA

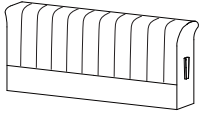

2 SEATER SOFA is packed in 3 cases

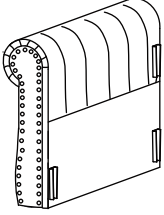
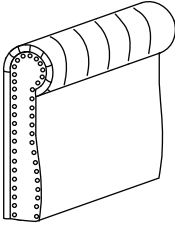
Carton	Disignation	Part	Hardware
1/3 WF306101	Backrest	#3 	
2/3 WF306102	Seat frame	#1 	 #A x 4pcs
	Seat cushion	#2 	
3/3 WF306105	Left arm	#4 	
	Right arm	#5 	

ASSEMBLY INSTRUCTIONS

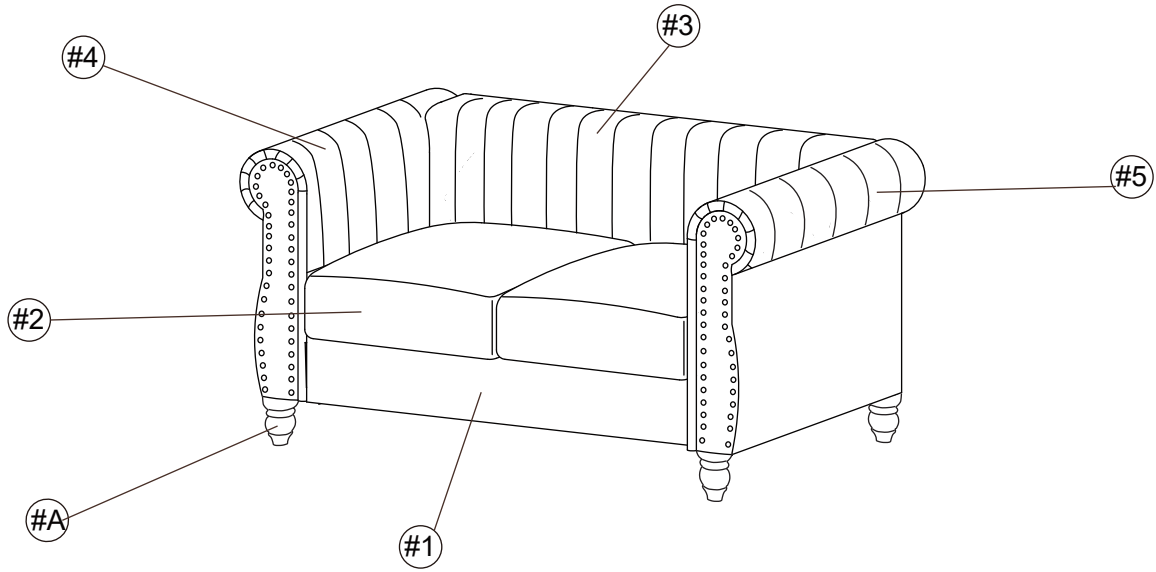

PARTS

#1 1pc



SEAT FRAME

#2 2pcs

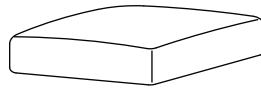

SEAT CUSHION

#3 1pc

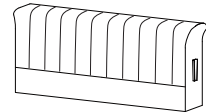

BACKREST

#4 1pc

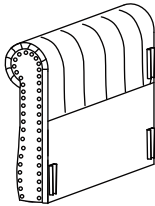

LEFT ARM

#5 1pc

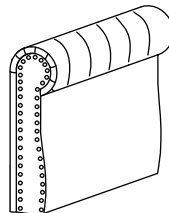

RIGHT ARM

HARDWARE

#A 4 pcs



WOODEN LEG

ASSEMBLY INSTRUCTIONS

1

Part #1 x1pc

Part #4 x1pc

Part #5 x1pc

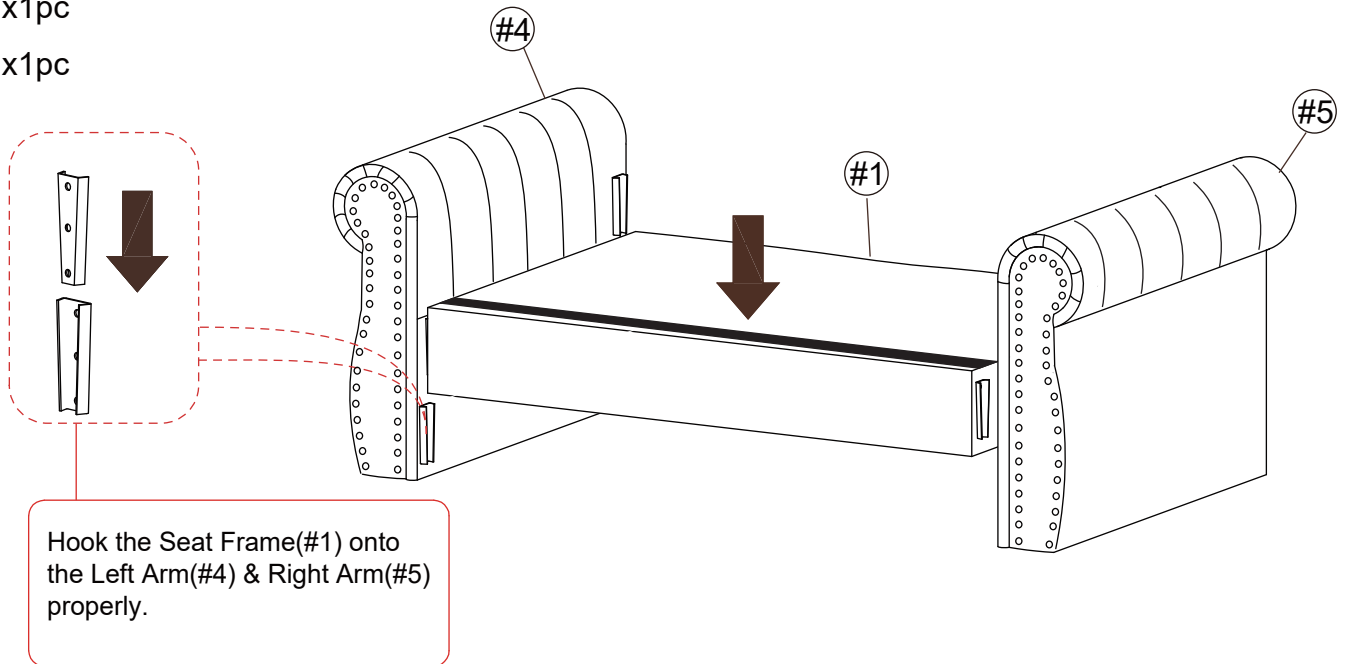

2

Part #3 x1pc

Part #4 x1pc

Part #5 x1pc

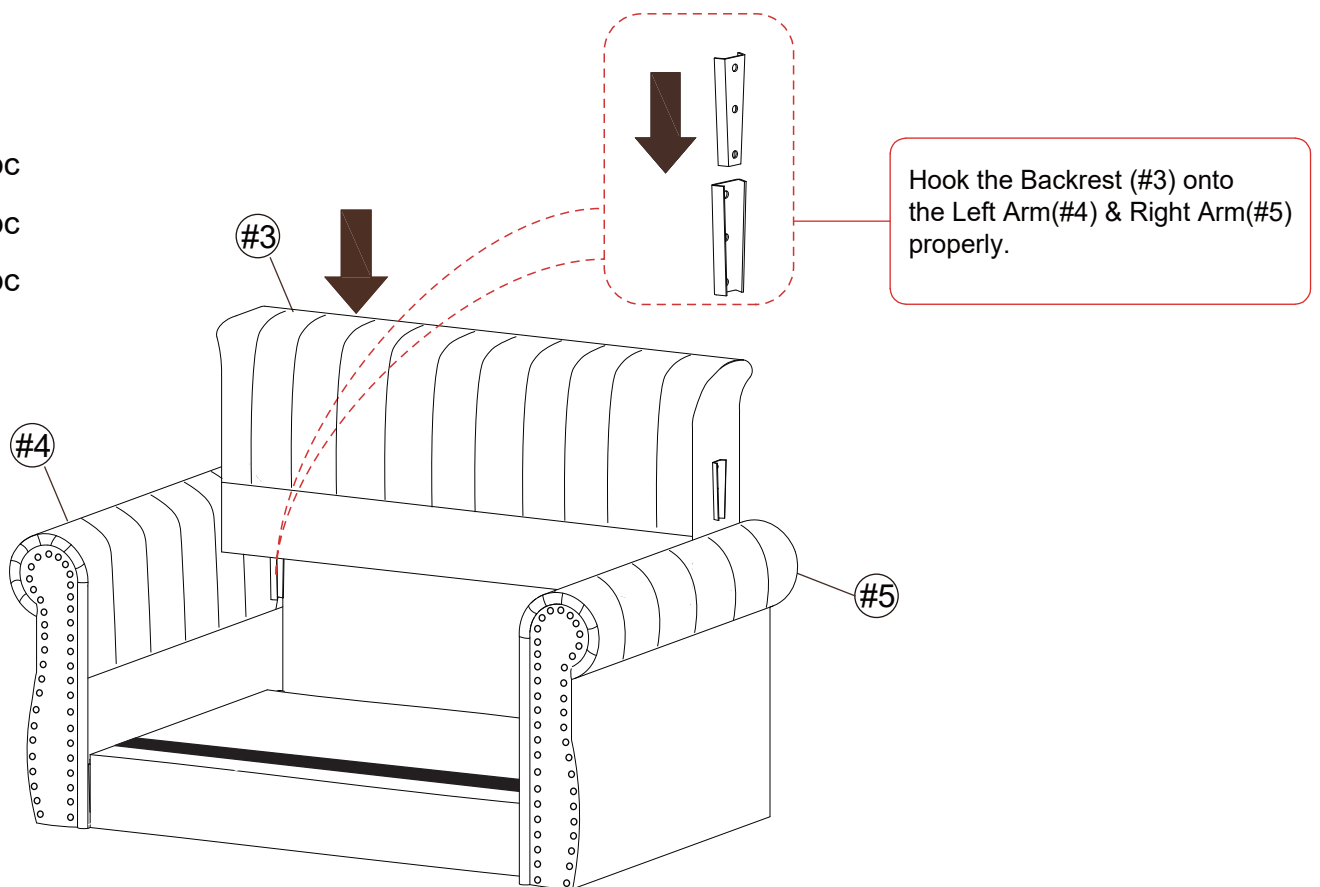

ASSEMBLY INSTRUCTIONS

3

Part #4 x1pc

Part #5 x1pc

Hardware #A x4pcs

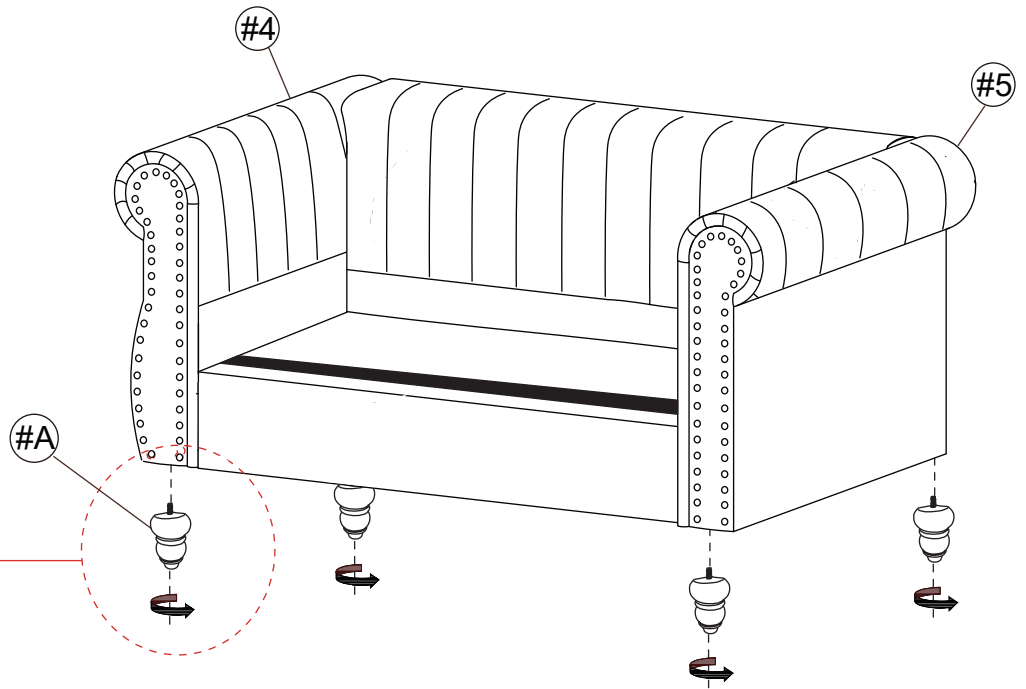

Align the Wooden Leg(#A) to Left Arm(#4) & Right Arm(#5) to the pre-drilled holes, then tighten the Wooden Leg(#A).

4

Part #2 x2pcs

Put the Seat Cushion(#2) on Seat Frame(#1)

