ASSEMBLY INSTRUCTION

BAR STOOL





Please carefully unpack and identify each component before beginning assembly. Before you begin, please refer to parts list to make sure that you have all parts. Please take care when assembling the unit and always place the parts on a clean, soft surface. If you require assistance with assembly or parts, please call 888-357-7263.

Get social with us and discover more about our products, tips and exclusive discounts!

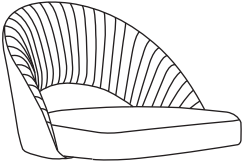

PRE-ASSEMBLY PREPARATION

- **CAUTION:** Assembly will require at least 2 adults. DO NOT use power tools. Please inspect all items BEFORE assembly. If for any reason you need to return this item, please kindly return it in its original packaging.
- **WARNING!**
 1. DO NOT let any sharp objects touch or rub the surface of the product.
 2. When assembling, do not let children play around the working area.
 3. DO NOT tighten all bolts and screws completely until the entire unit has been assembled and set up.
 4. DO NOT USE if this product become damaged, and/or components are broken or missing.
- **CARE AND CLEANING:** DO NOT scratch or chip the finish. DO NOT use abrasive chemicals for cleaning. Clean with mild soap on a soft rag. Rinse and dry thoroughly.
- **MAINTENANCE:** Please periodically check all fittings and re-tighten as necessary.

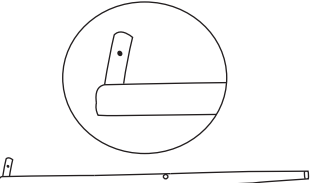
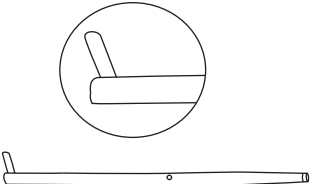
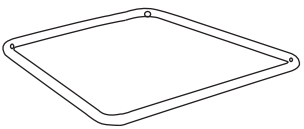
PARTS LIST

<p>SEAT (A)</p>  <p>Qty: 2</p>	<p>TOP CRISS-CROSS SUPPORT (B)</p>  <p>Qty: 2</p>	<p>BOTTOM CRISS-CROSS SUPPORT (C)</p>  <p>Qty: 2</p>	<p>FRONT LEG (D)</p>  <p>Qty: 4</p>
<p>BACK LEG (E)</p>  <p>Qty: 4</p>	<p>FOOTREST (F)</p>  <p>Qty: 2</p>		

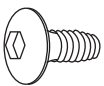
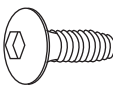
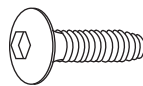
HARDWARE LIST

<p>ALLEN BOLT (G) M6X10MM</p>  <p>Qty: 16</p>	<p>ALLEN BOLT (H) M6X30MM</p>  <p>Qty: 10</p>	<p>ALLEN BOLT (I) M6X45MM</p>  <p>Qty: 8</p>	<p>ALLEN WASHER (J) M6X17X1.2MM</p>  <p>Qty: 10</p>	<p>ALLEN WRENCH (K)</p>  <p>Qty: 2</p>
--------------------------------------------------------------------------------------------------------------------------------------	--------------------------------------------------------------------------------------------------------------------------------------	-------------------------------------------------------------------------------------------------------------------------------------	----------------------------------------------------------------------------------------------------------------------------------------------	-----------------------------------------------------------------------------------------------------------------------------

STEP-BY-STEP ASSEMBLY

PLEASE CAREFULLY UNPACK AND IDENTIFY EACH COMPONENT BEFORE BEGINNING ASSEMBLY. BEFORE YOU BEGIN, PLEASE REFER TO PARTS LIST TO MAKE SURE THAT YOU HAVE ALL PARTS.

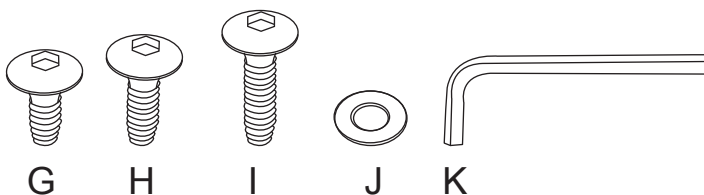
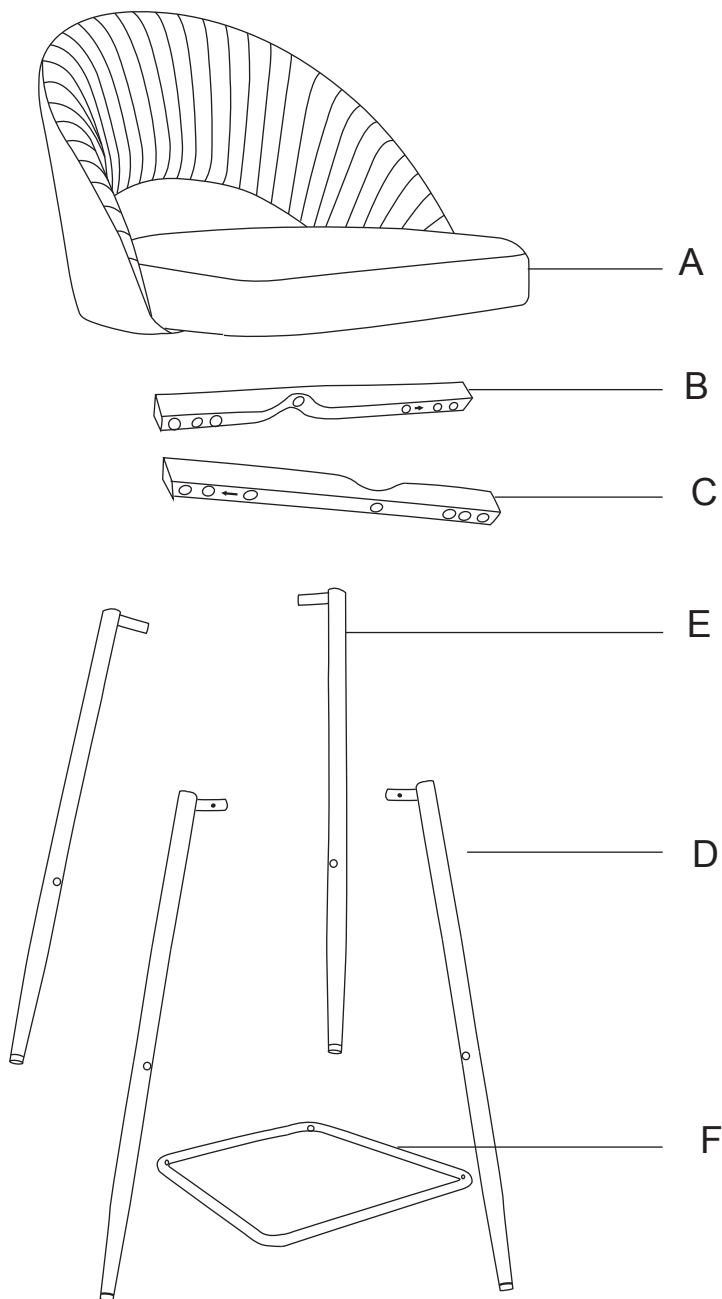

STEP 1 Insert the Front Legs (D) and Back Legs (E) to the Top Criss-Cross support (B) and Bottom Criss-Cross support (C) as shown in below diagram, please kindly pay attention to distinguish the front legs and back legs.

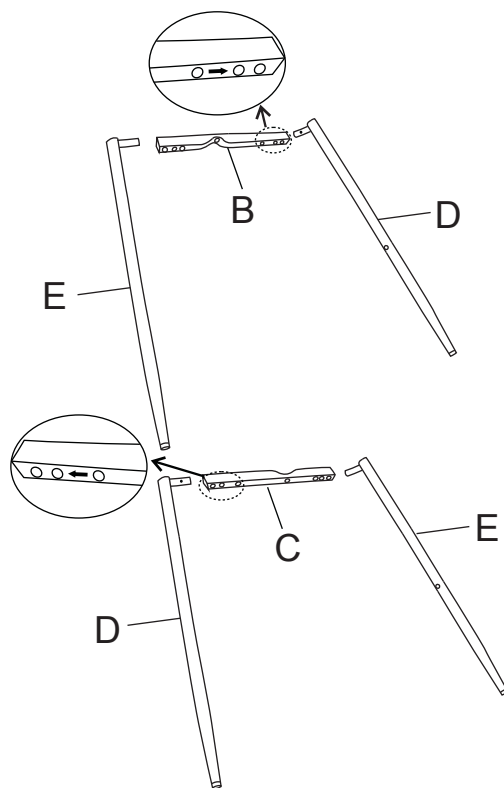

STEP 2 Please fix the Legs to Criss-Cross Supports as shown in below diagram by using Allen Bolt (G) and Allen Wrench (K), **Please tighten the bolts to 90%.**

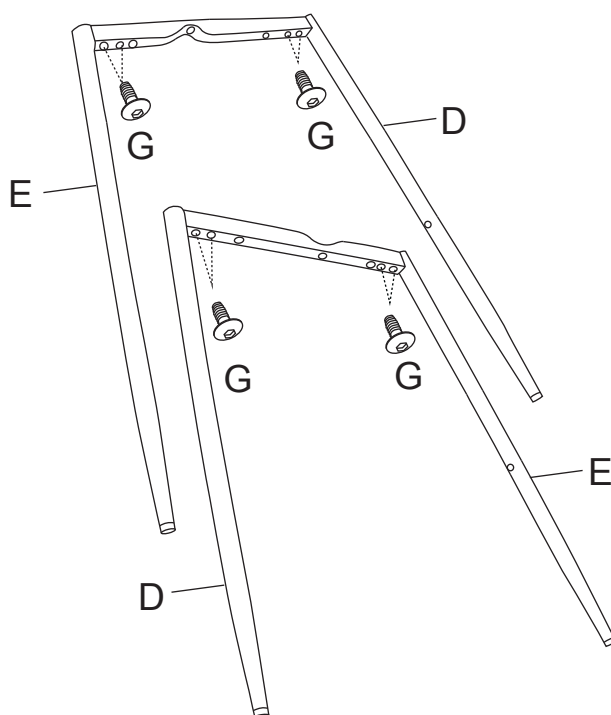

STEP 3 Attach the Bottom Criss-Cross support (C) to the Top Criss-Cross support (B) as shown in below diagram by using Allen Washer (J), Allen Bolt (H) and Allen Wrench (K), **Please tighten the bolts to 90%.**

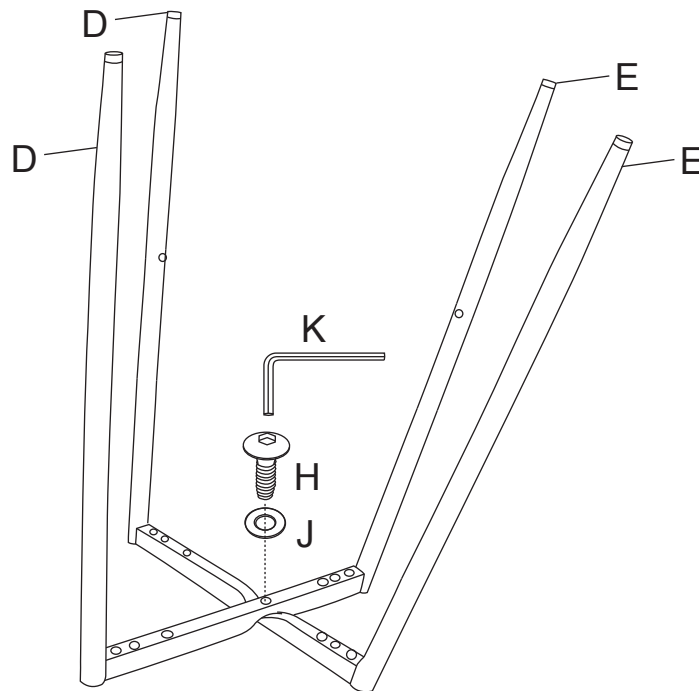

STEP 4 Attach the Legs (D&E) to the Seat (A) as shown in below diagram by using Allen Washer (J), Allen Bolt (I) and Allen Wrench (K), **Please tighten the bolts to 90%.**

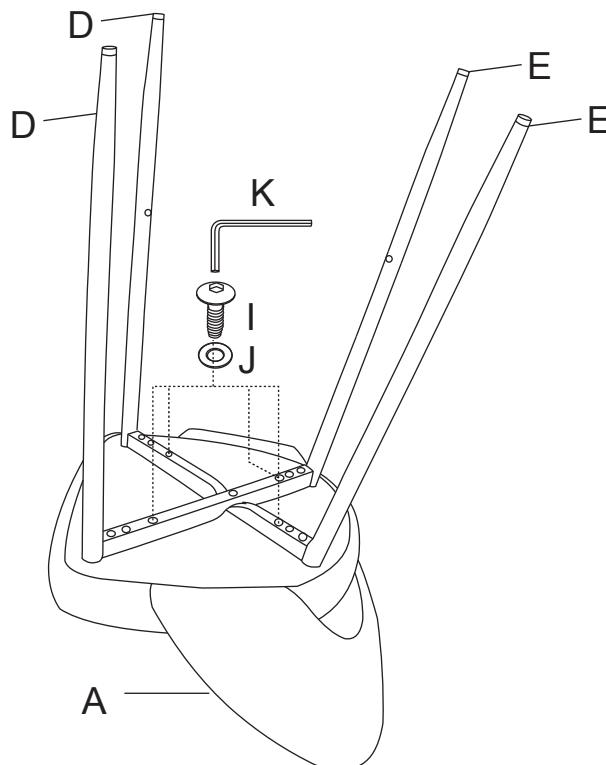

STEP 5 Attach the Footrest (F) to the Legs (D&E) as shown in below diagram by using Allen Bolt (H) and Allen Wrench (K), **Please tighten the bolts to 90%.**

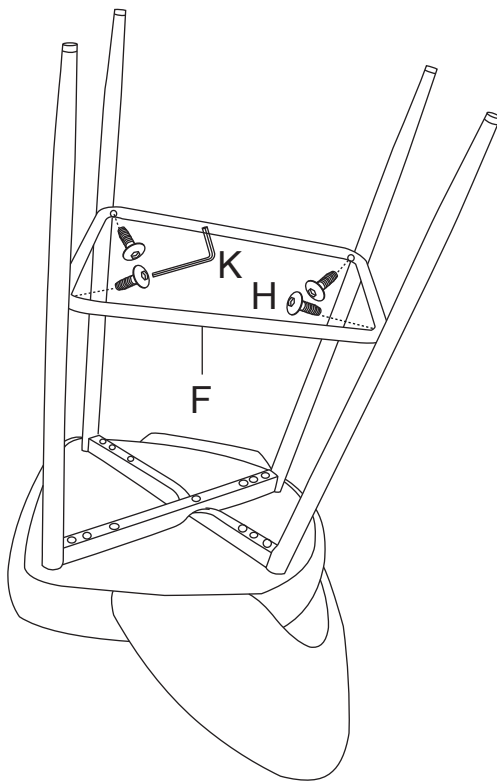

STEP 6 In this step please make sure the chair legs are flat and all bolts are installed, then please tighten all bolts to 100%.
A few days after initial assembly, the product may acclimate to its new environment. Please ensure all bolts are still securely tightened.

