

HEADBOARD AND FOOTBOARD SET ASSEMBLY INSTRUCTION (TOTAL 1 BOX)

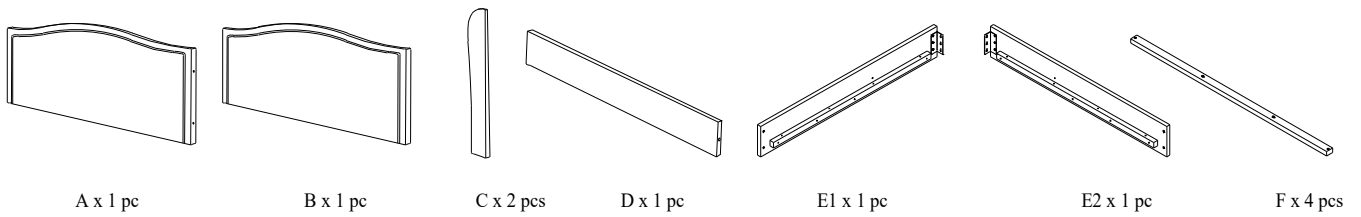

Please read over the instructions, it will be a time-saver in the long run.

Note: Before assembly, please be sure to work on a soft flat surface to avoid any damage to the finish.

Please leave bolts loosened until all bolts are placed before tightening completely.

Part#	Picture	Description	QTY	Location	Part#	Picture	Description	QTY	Location
G		Center leg	8	Wrapped in a non-woven bag	M		Bolt Ø6x30mm	6	Already in Place
H		Legs	2	Wrapped in a non-woven bag	N		Flat Washer Ø6x20mm	6	Already in Place
I		Bolt Ø8x60mm	12	Hardware Pack	O		Spring Washer Ø6	6	Already in Place
J		Flat Washer Ø8x25mm	12	Hardware Pack	P		"L" Wrenches Ø5	1	Hardware Pack
K		Spring Washer Ø8	12	Hardware Pack	Q		"L" Wrenches Ø4	1	Hardware Pack
L		Screws 4x50mm	8	Hardware Pack					

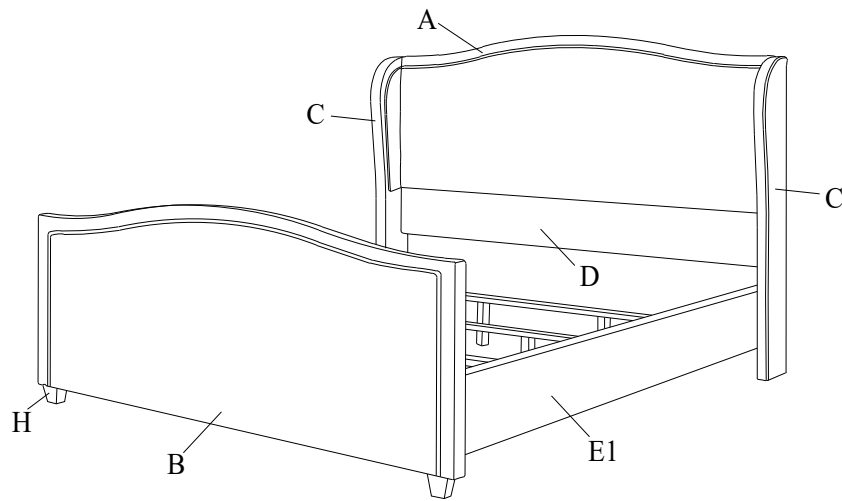

1

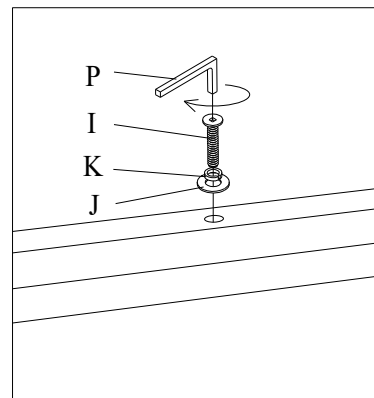
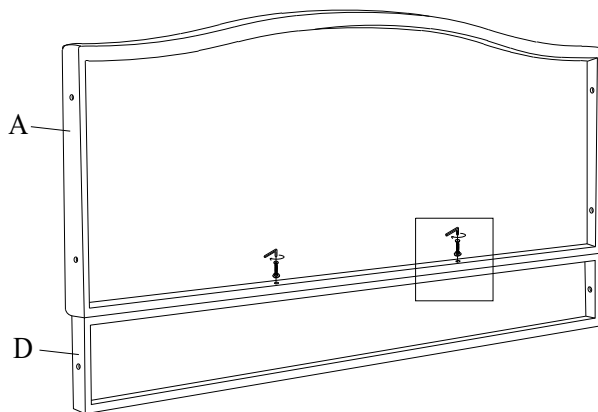

2

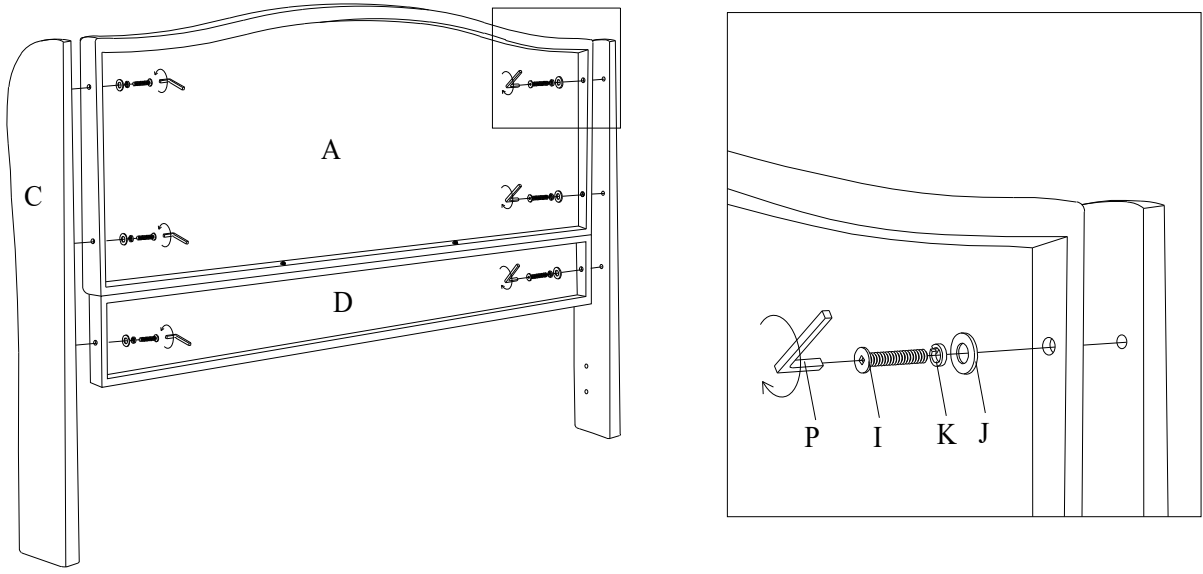

3

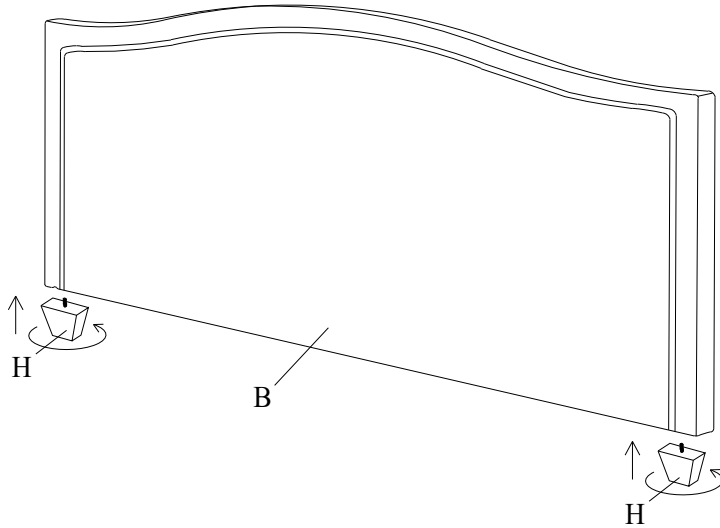

4

