

# Assembly Instructions

**Caution : You must read this before you proceed**

## Care & Maintenance



- ⊘  ● Not for commercial use. For residential use only.
- ✓  ● Furniture may scratch floors. We recommend using furniture pads to protect your floors.
- ⊘  ● Do not put hot items directly on furniture surface.
- ⊘  ● Do not clean furniture with harsh cleansers or polish.
- ⊘  ● Do not place furniture under direct sunlight.
- ⊘  ● Do not place furniture near heating or cooling vents.
- ⊘  ● Do not write on furniture without a padded barrier to protect the surface.
- ⊘  ● Do not place furniture outside . For indoor use only.
- ⊘  ● Stains may be removed with mild soap solution and damp cloth.
- ⊘  ● Children should not climb or jump on the furniture.
- ✓  ● Dust and pick-up spills using a clean, non-colored, lint-free cloth.

Sets often ship in multiple boxes and may arrive a day or two apart.

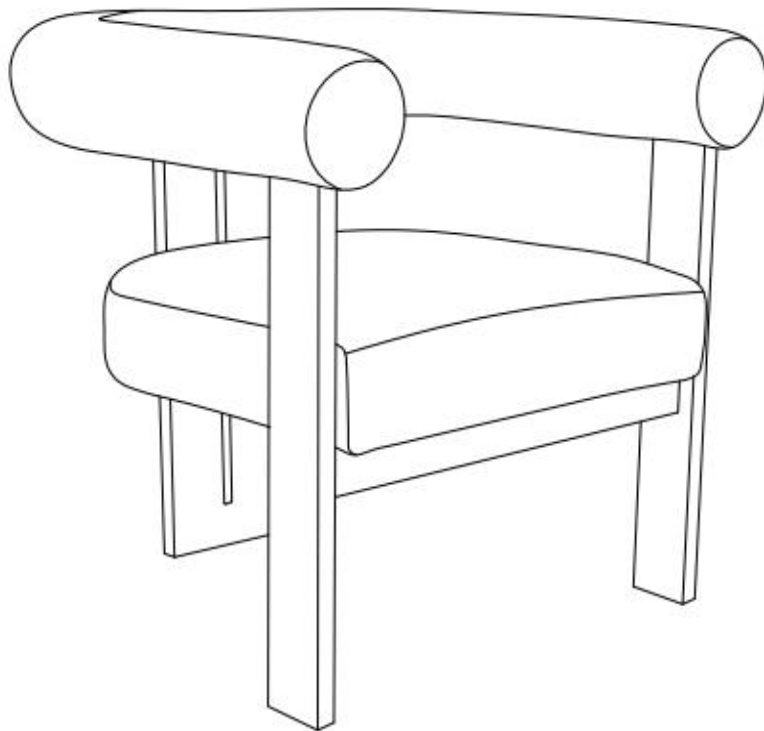
# Accent chair

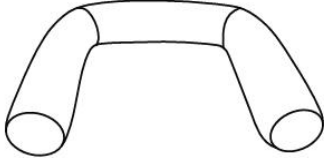
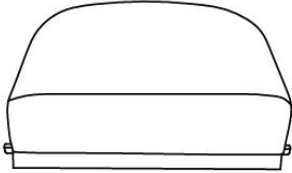

# Parts List

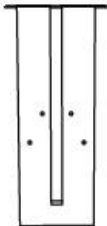
Label	Picture	Description	QTY
A		Backrest	1
B		Chair Seat	1
C		Left Front Leg	1
D		Right Front Leg	1
E		Hind Leg	1

# Hardwares

Label	Picture	Description	QTY
①		Bolt (M8*60 MM)	5
②		Bolt (M8*50 MM)	5
③		Bolt (M6*20 MM)	7
④		Spring Washer(M8)	9
⑤		Washer(M8*22MM)	9
⑥		Allen Wrench(M8)	1
⑦		Allen Wrench(M6)	1

## Assembly Preparation

**Before Beginning Assembly:**

A B C D E

① \*5    ② \*5    ③ \*7    ④ \*9    ⑤ \*9

⑥ \*1    ⑦ \*1



- Read instructions, cover to cover-



- Have 2 adults on hand for assembly-



- Do not assemble on flooring or carpet-



- Assemble on a clean non-marring surface (packing foam)-



- Save all packaging until finished-

# Assembly Steps

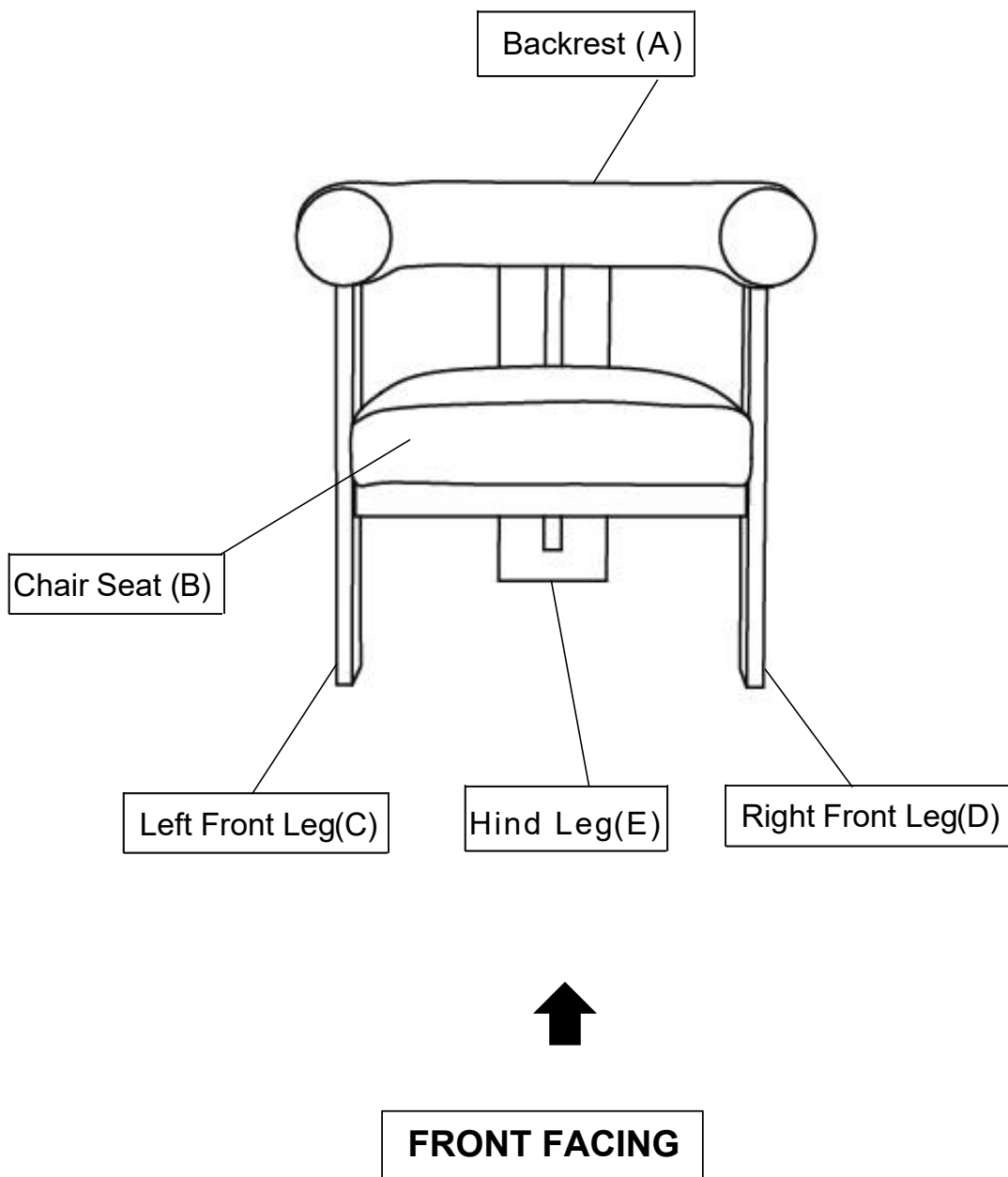

This Accent Chair has multiple parts and may require up to 30 minutes to assemble. To give you an overview of the Accent Chair parts, the above picture is to help you put the various parts into perspective. Please read through the instructions below to familiarise yourself with the parts and steps before assembly. Note: It is recommended that you have an adult partner to assist during the entire assembly process.

## Step 1

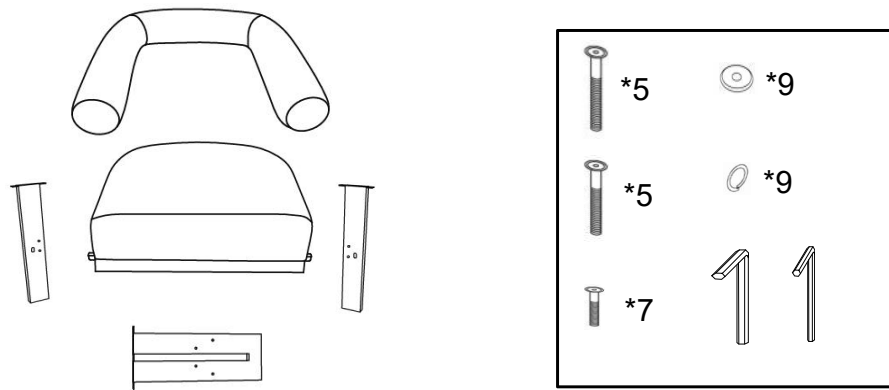

Position the Backrest(A), Chair Seat (B), Left Front Leg (C), Right Front Leg(D), Hind Leg(E) on a clean, non-marring surface as shown.

Carefully take out the Hardware from the Carton box.

## Step 2

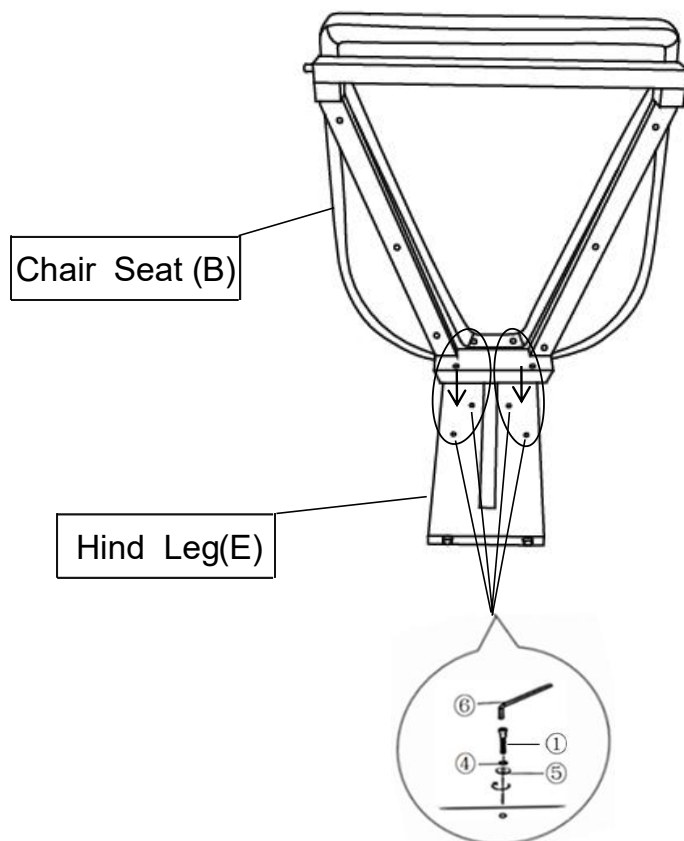

Lay the Hing Leg(E) flat, install the Hind Leg (E) into the Chair Seat (B) using a Bolts(①), Spring Washers(④), and Washers(⑤) with the Allen Wrench (⑥) as pictured above.

**After four bolts are in place, Tighten the Bolts fully in a sequential manner.**

**DO NOT fully tighten a Bolt in one go and then move on to the next.**

**Rather, In a sequential manner, gradually tighten each Bolt until all Bolts are evenly secured.**

### Step 3

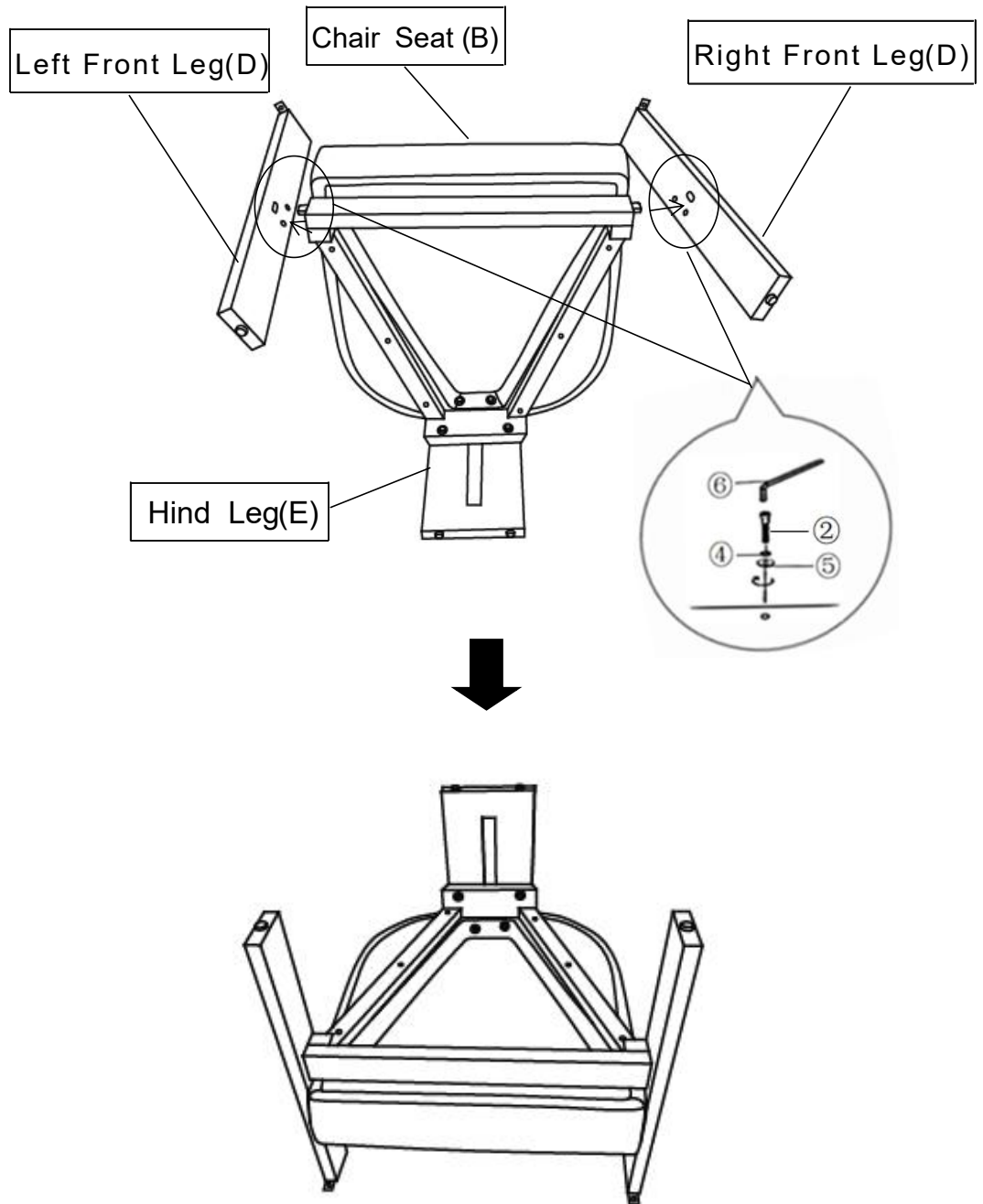

Install the Right Front Leg (D) into the Chair Seat (B) using a Bolts(②), Spring Washers(④), and Washers(⑤) with the Allen Wrench (⑥) as pictured above.

Repeat the same step to install the Left Front Leg (C) into the Chair Seat (B).

**Tighten the Bolts fully in a sequential manner.**

**DO NOT fully tighten a Bolt in one go and then move on to the next.**

**Rather, In a sequential manner, gradually tighten each Bolt until all Bolts are evenly secured.**

## Step 4

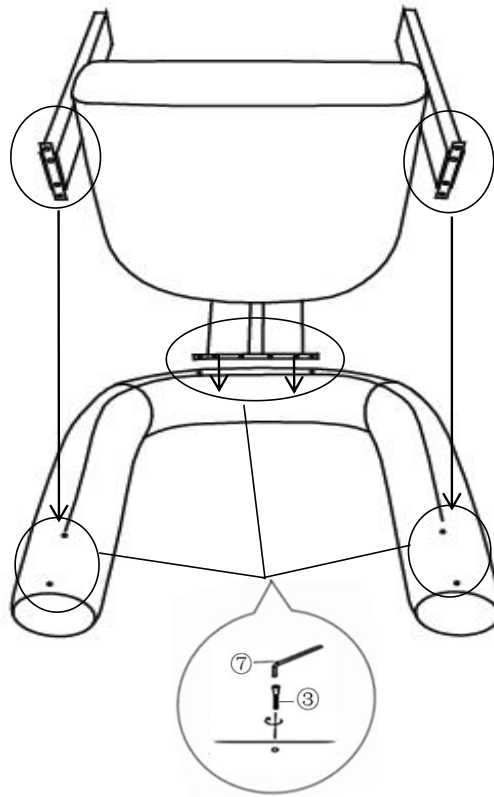

Up sidedown the Backrest(A) and put it on a non-marring surface, put the semi-assembled Chair Seat and legs on the backrest, overlap the steel plates to mounting holes of the Backrest (A). Attach the Legs to the Backrest (A) using a Bolts(③) with the Allen Wrench (⑦) as pictured above. **Tighten the Bolts fully in a sequential manner.** **DO NOT fully tighten a Bolt in one go and then move on to the next.** Rather, In a sequential manner, gradually tighten each Bolt until all Bolts are evenly secured.

## Step 5

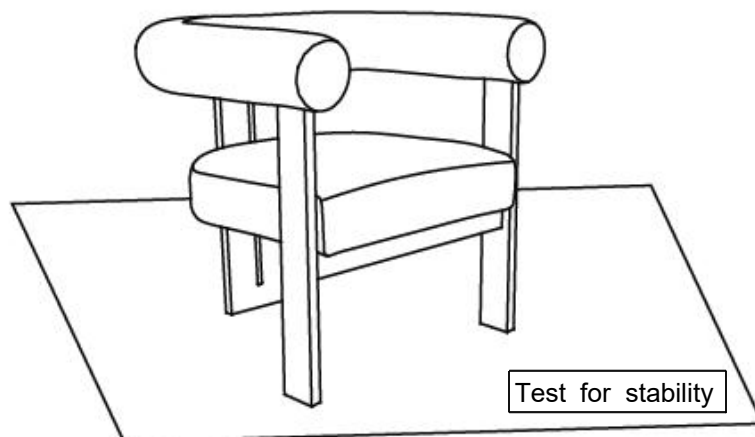

Your Accent chair is ready for use.  
This Accent Chair can only be used on a flat, level surface.