

TV55-MS LED FLOOD LIGHT

INSTALLATION, USAGE, & CARE GUIDE

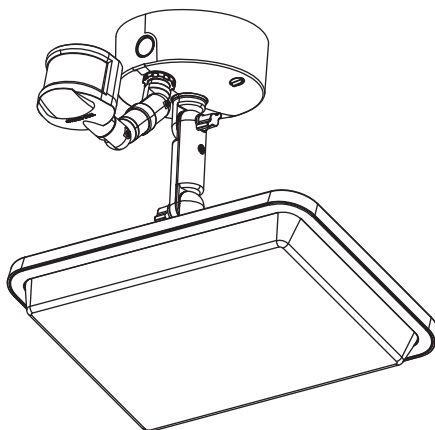

Questions? / Missing Parts? / Need Accessories?

Before returning to the store, call, text, or email PROBRITE
Customer Care 9am-5pm EST Monday to Friday.

1-844-507-5651

support@PROBRITE.com

PROBRITE.COM

TABLE OF CONTENTS

Table of Contents	2	Hardware Included.....	4
Safety Information	2	Installation	5
Pre-Installation	3	Operation	9
Planning Installation.....	3	Care & Cleaning	11
Specifications.....	3	Troubleshooting	11
Tools Required.....	3	Warranty	12
Package Contents.....	4		

SAFETY INFORMATION

IMPORTANT

THIS PRODUCT MUST BE INSTALLED IN ACCORDANCE WITH THE APPLICABLE NATIONAL ELECTRICAL CODE AND LOCAL BUILDING CODES BY A PERSON FAMILIAR WITH THE CONSTRUCTION AND OPERATION OF THE PRODUCT AND THE HAZARDS INVOLVED.

PRECAUTIONS

- Please read and understand this entire manual before attempting to assemble, install, or operate this light fixture.
- This light fixture requires a 120 Volt AC power source.
- Some codes require installation by a qualified electrician.
- This light fixture must be properly grounded.
- Make sure connections are secure using wire nuts, crimp-on lugs or other approved connecting devices
- This light fixture should be installed outdoors to a wall or eave.



WARNING: Turn the power off at the circuit breaker or fuse. Place tape over the circuit breaker switch and verify power is off at the light fixture.



WARNING: Risk of fire. Keep the fixture at least 3 in. (76mm) from combustible materials.



CAUTION: Burn hazard. Allow the light fixture to cool before touching.



NOTE: Do not connect this fixture to a dimmer switch.

INFORMATION: The device is tested and found to comply with Part 15 of the FCC Rules. Operation is subject to two conditions: (1) This device may not cause harmful interference and, (2) this device must accept any interference received, including any interference that may cause undesired operation.

These limits are designed to provide reasonable protections against harmful interference when the equipment is operated in a commercial environment.

PRE-INSTALLATION

PLANNING INSTALLATION

Before installing the light fixture, ensure that all parts are present. Compare parts with the **Hardware Included** and **Package Contents** sections. If any part is missing or damaged, do not attempt to assemble, install, or operate this light fixture.

SPECIFICATIONS

Lumens (Light Output)	1200 Outer Lumens, 4300 Inner Lumens
Watts (Power Consumption)	12 Watts, 33 Watts LED
Replaces	122W Halogen Bulb
Lumens/Watts (Efficacy)	100, 130 Lumens per watt
Power Requirements (Input Voltage)	120V
Light Color (CCT)	4000 Kelvin
Dimmable	Non-Dimming (Do not wire to dimming switch)
Operating Modes	<p>Dusk-to-Dawn: Automatically turns light fixture ON during night and OFF during day.</p> <p>Motion-Sensing: Automatically turns light fixture ON when motion is detected.</p> <p>Switch-Controlled: Flip switch to turn light fixture ON and OFF. Cover fixture's light sensor to utilize this mode setting..</p>

TOOLS REQUIRED



Phillips screwdriver



Wire strippers/
cutters



Circuit tester



Silicone sealant



Work gloves



Ladder



Safety goggles

PRE-INSTALLATION (CONTINUED)

PACKAGE CONTENTS

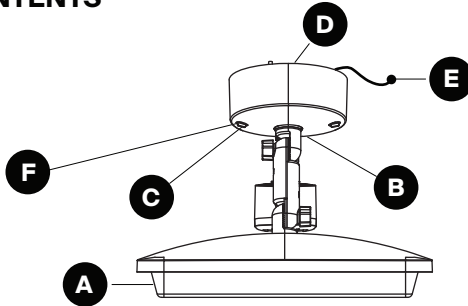

Part	Description	Quantity
A	Light fixture	2
B	Control sensor	1
C	Mounting plate set screw (pre-installed)	1
D	Mounting plate with gasket (pre-installed)	1
E	Hanger wire for hands-free installation (pre-installed)	1
F	Mounting screw cover plug	1

HARDWARE KIT



NOTE: Hardware *not* shown to actual size.

AA

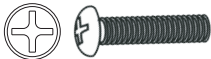

BB

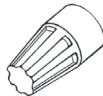

Part	Description	Quantity
AA	#8-32 x 3/4" Phillips head screw	2
BB	Wire nut	3

INSTALLATION

1 FOR BEST RESULTS

- Install light 8-15 feet above the ground.
- Do not mount fixture close to reflective surfaces such as windows, white walls, white surfaces and water.
- Do NOT wire to dimming switch.
- When mounting fixture, make sure the control sensor orientation is at the bottom for wall mount (fig 1) and away from building for eave mount (fig 2).
- When mounting to a wall, make sure the fixture is 7 in. on center away from eave and 13 inches on center away from inside corner of the exterior wall (fig 3).

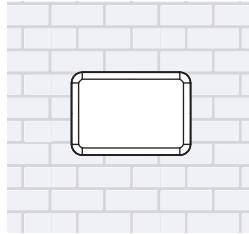

Wall Mount

(fig 1).

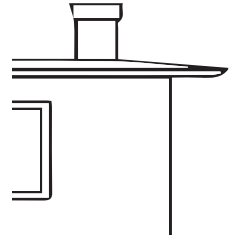

Eave Mount

(fig 2).

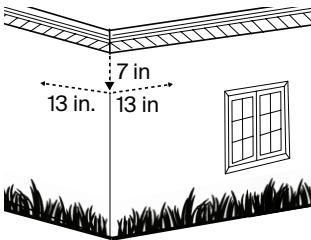

(fig 3).



NOTE: Mounting plate (D) mounts to standard recessed junction boxes. Junction box must be at least 1-1/2 inch deep for proper surface mount installation (fig 4).

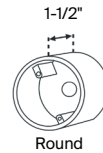

(fig 4).

Round

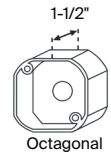

Octagonal

2 SHUT ELECTRIC POWER OFF

- Verify wall switch is in OFF position (fig 5).
- At the main electrical panel, turn off the circuit breaker that supplies power to the junction box you are working on (fig 7).
- For screw-in type fuses, unscrew the fuse that supplies power to the junction box you are working on (fig 6).

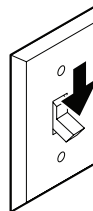

(fig 5).

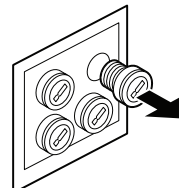

(fig 6).

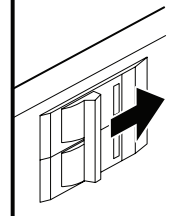

(fig 7).

INSTALLATION (CONTINUED)

3 REMOVE THE MOUNTING PLATE



NOTE: The mounting plate (D) come pre-assembled on the light fixture (A) for shipping.



NOTE: The mounting plate set screw (C) comes pre-installed on the light fixture.

- Remove the mounting plate bracket (D) from the back of the fixture by removing the mounting screw cover plug (F) and then loosening the mounting screw (C) using a philips head screwdriver.

TIP: Only unscrew the tightening screw (C) far enough to remove the mounting plate bracket (D). Do not fully remove the set screw (C).

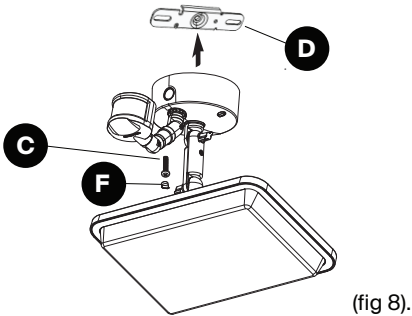

4 INSTALL THE MOUNTING PLATE

- Route the junction box wires through the large center hole in the mounting plate bracket (D).
- Align the holes on the mounting plate bracket (D) with the holes of the junction box. Use two #8 screws (AA) to attach the mounting plate bracket (D) to the junction box.

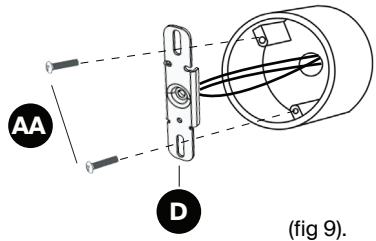

INSTALLATION (CONTINUED)

5 MAKE THE ELECTRICAL CONNECTIONS

- **For wall mount**, ensure the control sensor (B) is facing downwards when light fixture (A) is installed.
- **For eave mount**, ensure the control sensor (B) is facing away from the building when light fixture (A) is installed.
- If necessary, strip 3/8" of insulation from junction box and lighting fixture wires (fig 10). Connect wires by twisting the exposed wires together and using the wire nuts (BB). Ensure no loose wires.
- Connect lighting fixture black wire to junction box black wire (line), lighting fixture white wire to junction box white wire (common), the junction box ground wire to the green lighting fixture ground wire, which is attached to the mounting plate.

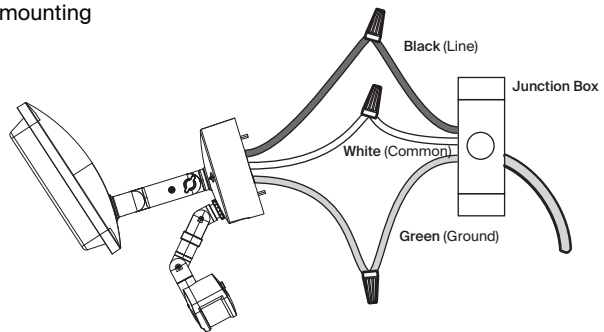
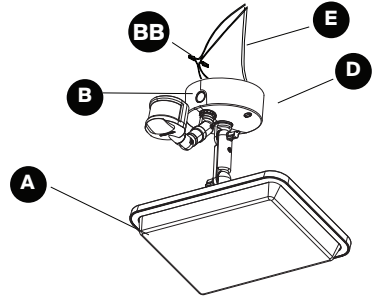

Non-Dimming Wiring Diagram

(fig 10).

TIP:

Hold stripped ends near each other and align any frayed strands (do not twist wires).



Push the wires into wire nut (BB) and use your fingers to twist the wire nut clockwise until tight. Check for tightness by pulling wires.

INSTALLATION (CONTINUED)

6 MOUNT THE LIGHT FIXTURE

- Once wiring is complete, align the mounting screw hole in the center of the fixture with the screw hole in mounting plate bracket (D).
- Verify the fixture is flush with the wall and control sensor (B) is pointed downward for wall mount or away from building on eave mount.
- Insert the mounting plate set screw (C) back through the hole in the center of the fixture and tighten until fixture is firmly secured against the wall or eave.

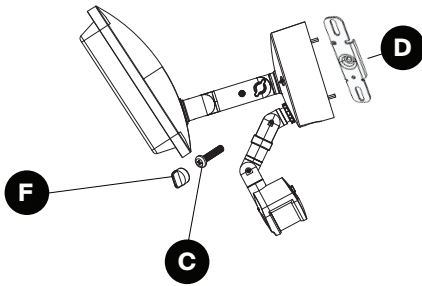

(fig 11).

8 CAULK AROUND THE LIGHT FIXTURE

- Caulk around the light fixture (A) and surface with silicone sealant (not included).

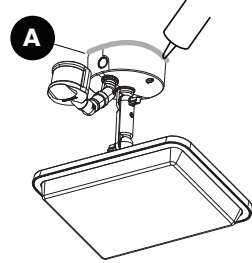

NOTE: Failure to properly caulk around the surface and light fixture (A) could lead to water damage and is not covered under warranty.



NOTE: When attaching this fixture (A) to a surface mount junction box, caulk between the light fixture and junction box.

(fig 13).

7 AIM THE LAMP HEADS

- After fixture is securely mounted, loosen screws on the lamp head arms with a philips screwdriver.
- Aim each lamp head (A) toward desired direction.
- Use a philips screwdriver to tighten the lamp head arm screws, locking lamp heads in desired position.
- From the breaker and switch, turn power back ON to the light fixture to verify it illuminates. Make sure the control sensor (B) has no light entering it when testing.

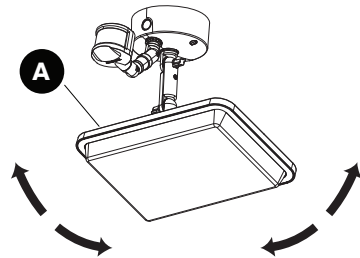

CAUTION: Keep lamp heads 30° below horizontal to prevent water damage and electrical shock.

(fig 12).

CONTROL SENSOR OPERATING INSTRUCTIONS

The control sensor on this product will turn on the light fixture when it detects motion. The motion sensing can be disabled for Dusk-to-Dawn operation using the built-in photosensor that automatically turns the light fixture on during night and off during daytime. All sensors can be disabled for manual wall switch control.

□ Setting up control sensor

Step 1: Testing motion activation

The motion sensor must be tested before setting the time and sensitivity levels. The TEST option is located on the TIMER control knob on the underside of the sensor head (fig 14.). To test the fixture, switch the wall switch that controls power to the fixture to the ON position and turn the rotary knob to "TEST". During TEST mode, the lights will come on for 20 seconds, regardless of motion detection or the time of day. The light will shut off automatically after 20 seconds. Leave the rotary knob in the "TEST" position and test the sensitivity by crossing in the path of the sensor. The light will come on only if it senses movement. Once movement stops, it will turn off in 5 seconds. The test is now complete.

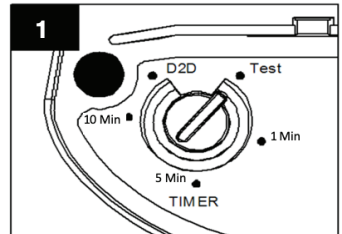

(fig 14).

Step 2: Setting "STAY ON TIME" duration after motion detection

The TIMER settings indicate how long the light stays on after the control sensor detects motion. Once the fixture has been tested for proper operation and sensitivity, rotate the TIMER control knob clockwise to set the "stay on time" of the motion sensor. TIMER can be adjusted up to 10 minutes ON time. Rotating the knob counterclockwise shortens the "stay on time" to as short as 10 seconds. It may be necessary to adjust the TIMER knob several times until the desired ON duration time is achieved. (fig 15)

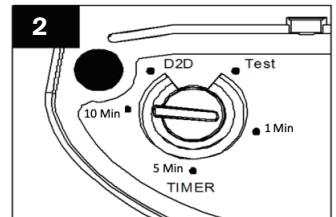

(fig 15).

□ Adjusting motion sensitivity

The control knob located on the opposite side is marked SENSITIVITY (fig 16), and determines the degree of motion detection. Rotating this knob clockwise raises the sensitivity of the motion sensor for up to 60 ft. of distance. Rotating the knob counterclockwise lowers the sensitivity down to as close as 10 ft. It may be necessary to adjust the SENSITIVITY knob several times until the desired setting is achieved.

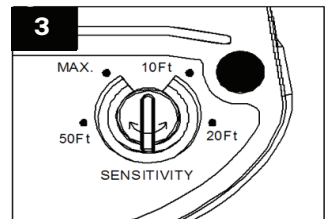

(fig 16).



NOTE: The higher sensitivity level increases the likelihood of a false activation being triggered.

OPERATION (CONTINUED)

□ Aiming control sensor for best performance

The 180-degree coverage of the motion sensor is measured side to side. Therefore, the sensor will better detect motion across the field of view (side-to-side), rather than motion coming straight at the sensor (in-and-out). Adjust the motion sensor head so that it detects motion moving across the desired area. The position of the sensor head should not exceed 45 degrees from horizontal. Do not aim the motion sensor at a body of water, bushes or plants that may move in the wind, pedestrian traffic, moving cars, etc., as this will trigger the motion sensor.

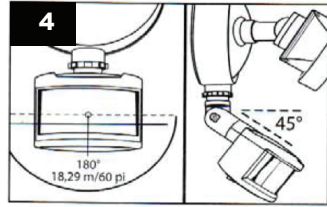

(fig 17).



NOTE: If the sensor arm becomes loose, it will not hold the sensor head at the joint screw on the sensor arm.

□ Bypassing motion activation for Dusk-to-Dawn operation

Rotate the TIMER control knob to the “D2D” position (fig 18). The light will turn on at dusk and off at dawn automatically, regardless of the presence of motion. The “D2D” setting ensures lights are non-operational in daylight and only function at night.

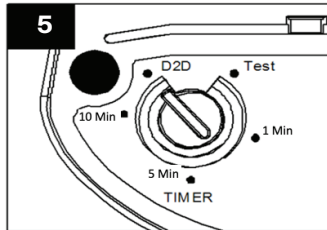

(fig 18).

□ Manual override

When the TIMER control knob is set between “1 Min” and “10 Min” (fig 19), the sensor is in Auto mode at this time. To control the light from inside the home, activate manual override mode by toggling the wall light switch OFF and ON within 2 seconds. The security light will turn on and stay on for approximately 8 hours, or until the Dusk-to-Dawn sensor detects light in the morning. Once the Dusk-to-Dawn sensor detects light, the manual override mode will automatically go back to its original settings of the AUTO motion sensor.

Manual Override Operating Diagram

Turn wall switch OFF-ON within 2 sec



Turn wall switch OFF-ON within 2 sec
or
automatically resets after 8 hours

(fig 19).

LIGHT OPERATION

MODE	CONTROL KNOB	WALL SWITCH	SENSITIVITY KNOB
Test mode.	Test position.	On.	Any setting.
AUTO motion sensor mode.	Timer set between “1 Min” and “10 Min”.	On.	Any setting.
Dusk-to-Dawn mode.	D2D position.	On.	Any setting.
Manual override mode.	Timer set between “1 Min” and “10 Min”.	Toggle OFF and ON within two seconds.	Any setting.
Return to AUTO motion sensor mode.	Timer set between “1 Min” and “10 Min”.	On.	Any setting.

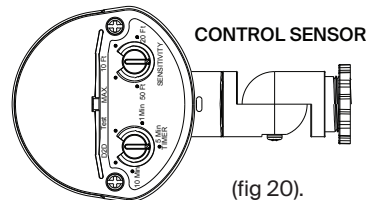

(fig 20).

CARE AND CLEANING

- Shut off main power supply before cleaning the product. To prolong the original appearance, clean the light fixture with clear water and a soft, damp cloth only.
- Do not use abrasive cleaners or cleaners that contain alcohol. Do not apply paints, solvents, or any other chemicals on this light fixture. They could cause a premature deterioration of the finish and may void the warranty.
- Do not spray the light fixture with a hose or power washer.

TROUBLESHOOTING

Extreme hot or cold weather could affect the performance of the built-in sensors that detect body heat. Certain winter clothing can shield a person's body heat from the sensor during extreme cold weather. During extreme hot weather, the sensor may not be able to distinguish the difference between normal body temperatures and the surrounding high temperatures. The sensor will begin working normally once weather conditions return to normal.

PROBLEM	POSSIBLE CAUSE	CORRECTIVE ACTION
Light does not come on at night when motion is detected.	<ol style="list-style-type: none"> 1. No power is being delivered to the fixture. 2. Another light source is causing the security light to think it is daylight. 3. Dusk-to-Dawn sensor is faulty. 	<ol style="list-style-type: none"> 1. Check that circuit breaker and/or wall switch power is on. 2. Turn off surrounding lights and/or re-aim the sensor head. 3. Re-connect any loose wiring.
Security light comes on during the day.	<ol style="list-style-type: none"> 1. Wiring inside electrical box came loose. 2. Dusk-to-Dawn sensor is in shaded area and is fooled into thinking it is nighttime. 	<ol style="list-style-type: none"> 1. Shine a flashlight onto the light sensor. If the security light turns off then the fixture is mounted in an area that does not allow enough light to enter the sensor. Relocate security light. 2. If under warranty, contact Customer Service.
Security light cycles ON and OFF continuously.	<ol style="list-style-type: none"> 1. Dusk-to-Dawn sensor is sensing reflected light from the security light. 	<ol style="list-style-type: none"> 1. Change the position of the light head, aim light away from the reflecting surfaces. 2. Put a small piece of black electrical tape over the Dusk-to-Dawn sensor. 3. Relocate the security light to a different location where it no longer causes reflected light.
Security light comes on for no apparent reason at night.	<ol style="list-style-type: none"> 1. Light is sensing motion in the detection zone. 	<ol style="list-style-type: none"> 1. Make sure the sensor is not picking up moving objects such as bushes, trees, traffic, water, etc. 2. Test the motion sensor by covering up the front curved lens with cardboard to block the view. If the light turns off then something in the detection zone is triggering the sensor. Reposition the motion sensor or change the sensitivity (distance) of the sensor.



NOTE: Control sensor (B) may have a few minutes delay in D2D mode due to its sensitivity to sudden light changes. When testing, shine a light/cover the control sensor for a few minutes to check if fixture functions properly.

5-Year Limited Warranty

This is a limited warranty offered by Probrite for a period of five years from the date of purchase to its customers. Probrite warrants to customers that the products will be free from defects in material and workmanship. The obligation of Probrite under this warranty is limited to the provision of replacement of products and is extended to the original purchaser of the product on presenting valid purchase receipt or other proof of date of original purchase acceptable to Probrite. The receipt is required for rendering the warranty performance. Any warranty claims without original proof of purchase would not be accepted.

It should be noted that the warranty does not apply to Probrite products that have been altered or repaired by unauthorized personnel, have been subjected to neglect, abuse, misuse or accident or damages caused during shipping. Any other products not manufactured by Probrite which have been supplied, installed and/or used in conjunction with Probrite products are not covered under this warranty. Any damages caused by replacements bulbs, LEDs or corrosion or discoloration of brass components are also not covered by this warranty.

Limitation of Liability:

In no event Probrite shall be liable for indirect, consequential, incidental or special damages, or lost profits. Probrite is not liable for any claims or damage arising out of or connected with the manufacture, sale, delivery, use, maintenance and repair or modification of Probrite products, or supply of any replacement parts that, exceed the purchase price of Probrite products giving rise to a claim. Labor charges to remove or install the fixtures will not be accepted.

To Claim:

Please contact PROBRITE customer service at 1-844-507-5651 or email support@probrite.com and include your name, address and contact number, along with a copy of the purchase receipt and a brief description of the problem.

PROBRITE®

Questions? / Missing Parts? / Need Accessories?

Before returning to the store, call or email our
Lighting Specialists 9am-5pm EST Monday to Friday.

1-844-507-5651

support@probrite.com

www.probrite.com

RETAIN THIS MANUAL FOR FUTURE USE

Para las translaciones en español,
visit www.probrite.com/install