

## Bed Frame with Storage Headboard & Charging Station Assembly Instructions



### **Dear Customers,**

Thank you for purchasing our product. Please read this instruction manual carefully after receiving this product. It will help you assemble this product quickly, safely and correctly. You can keep this manual for future reference.

MADEINCHINA

## ! IMPORTANT

Please follow the instruction manuals and use a pad to protect the product during your assembly.

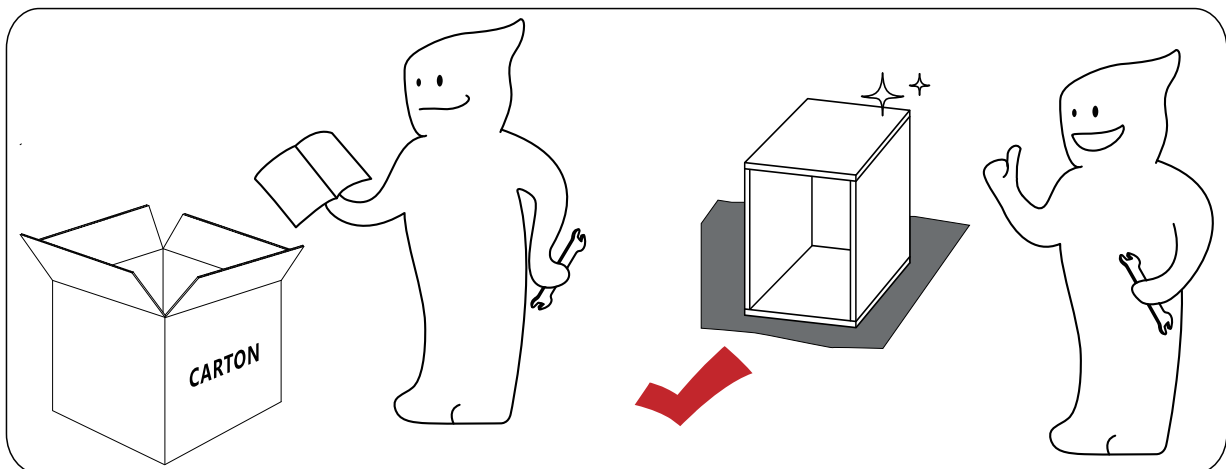
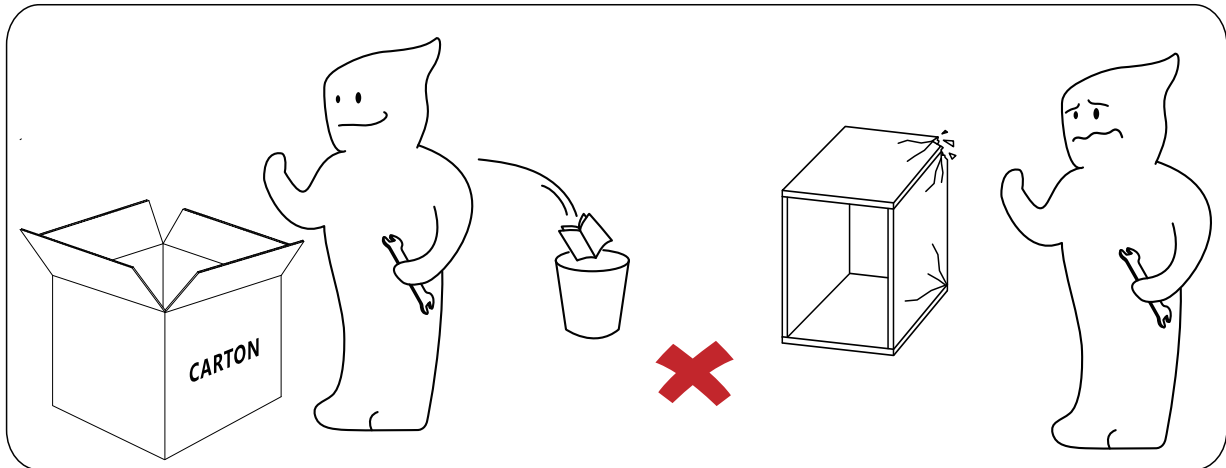

**Note:**

1. Should be assembled on flat ground to keep balance.
2. Before completing the installation, do not tighten the screws.

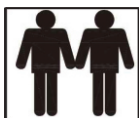

For easier and better assembly, **2** or more adults are required.



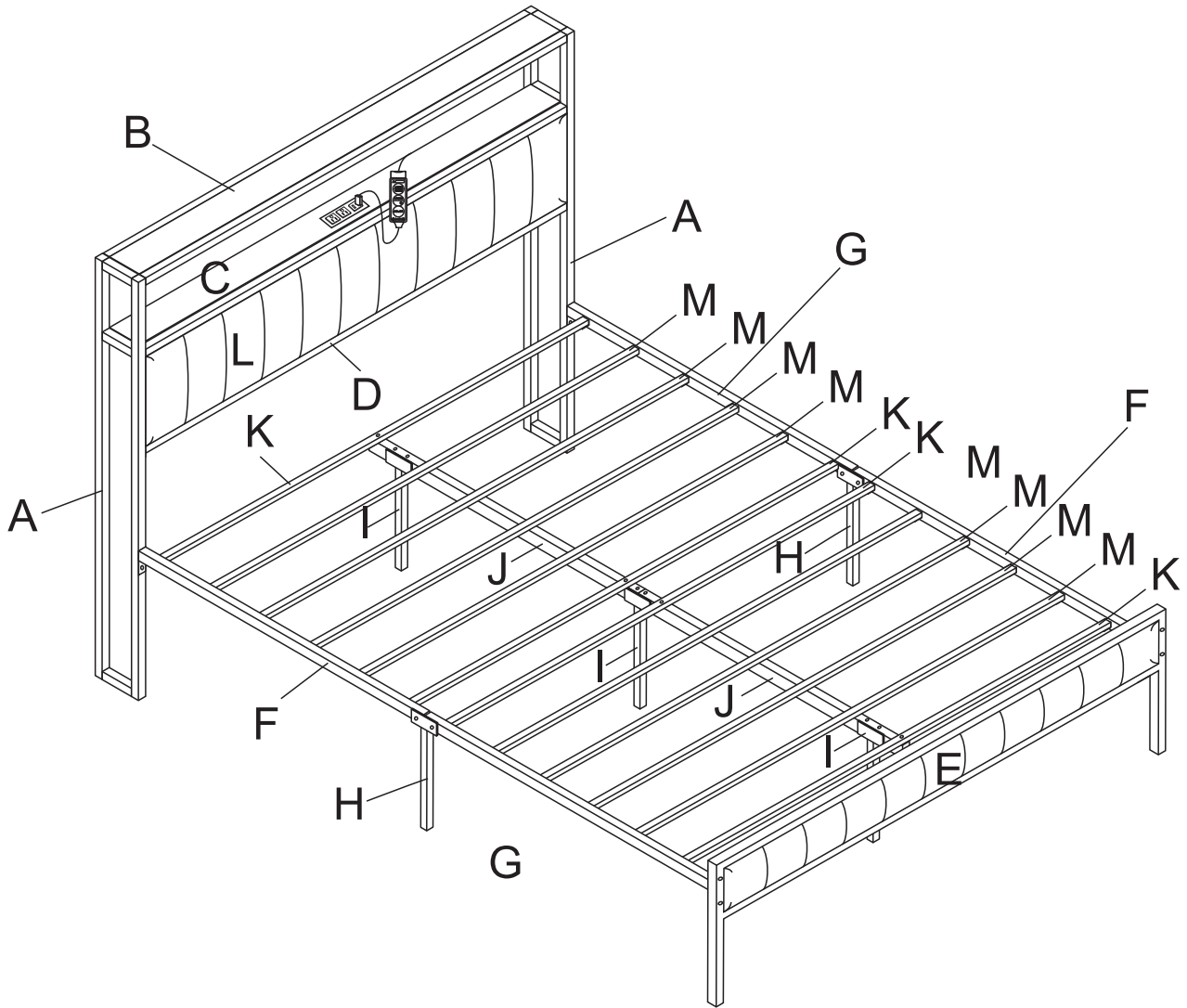



# ASSEMBLY INSTRUCTIONS

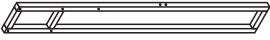
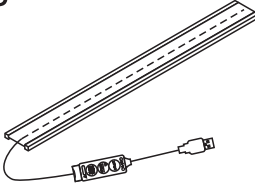
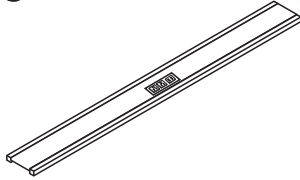
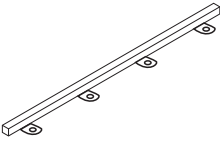
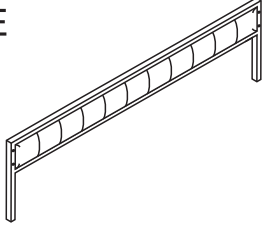
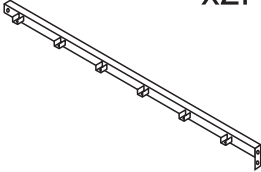
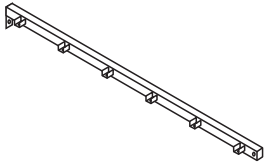
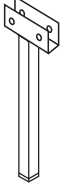
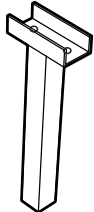
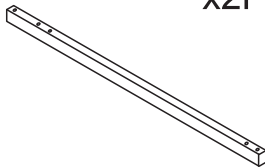
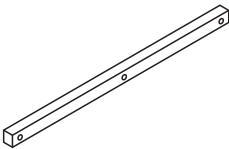
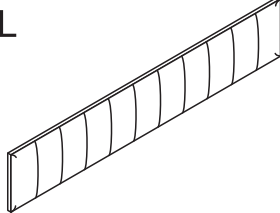
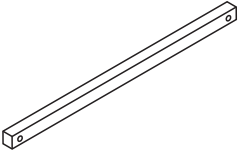

Notice: Do not tighten the screws too tightly at the beginning of the assembly. After each hole position is matched well, with gently force to screw, if there is no problem, then tighten all the screws.

# ASSEMBLY INSTRUCTIONS

## PARTSLIST

<p>A x2PCS</p> 	<p>B x1PC</p> 	<p>C x1PC</p> 		
<p>D x1PC</p> 	<p>E x1PC</p> 	<p>F x2PCS</p> 		
<p>G x2PCS</p> 	<p>H x2PCS</p> 	<p>I x3PCS</p> 		
<p>J x2PCS</p> 	<p>K x4PCS</p> 	<p>L x1PC</p> 		
<p>M x8PCS</p> 				
<p>1 x22PCS</p>  <p>M8x40mm</p>	<p>2 x8PCS</p>  <p>M6x13mm</p>	<p>3 x6PCS</p>  <p>M6x35mm</p>	<p>4 x28PCS</p>  <p>M6x25mm</p>	<p>5 x1PC</p> 

# ASSEMBLY INSTRUCTIONS

1

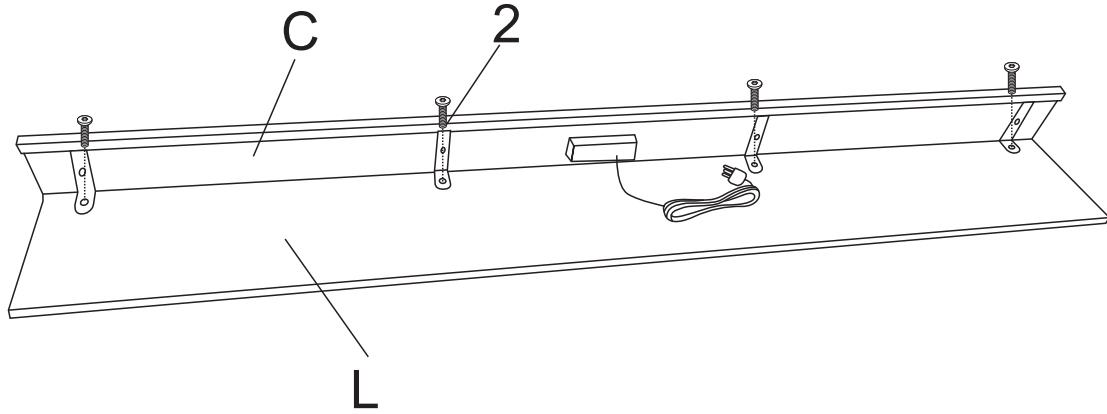

2		4PCS
	M6x13mm	

2

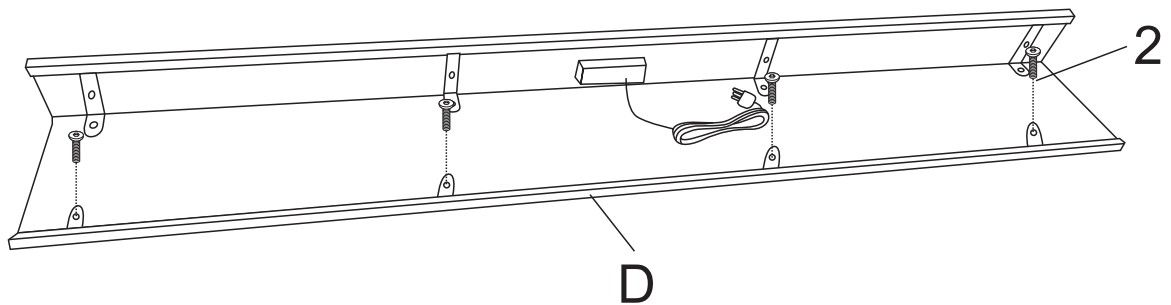

2		4PCS
	M6x13mm	

# ASSEMBLY INSTRUCTIONS

3

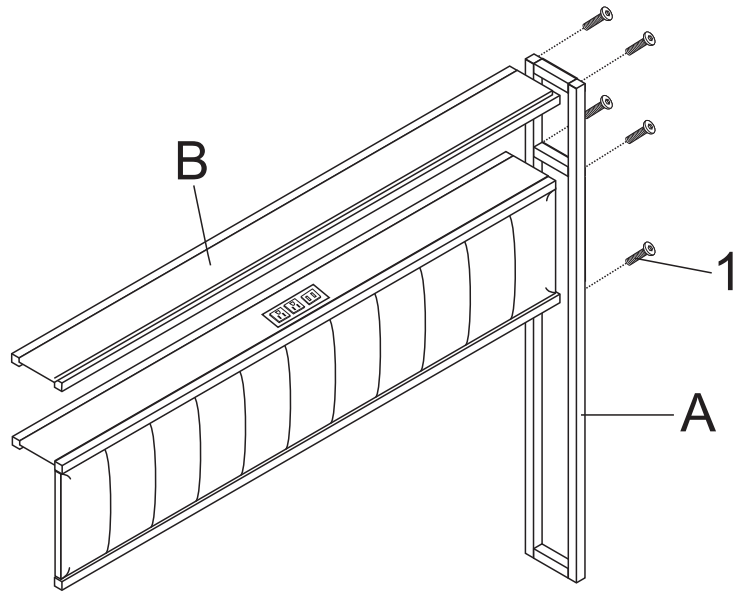

1	 M8x40mm	5PCS
---	--	------

4

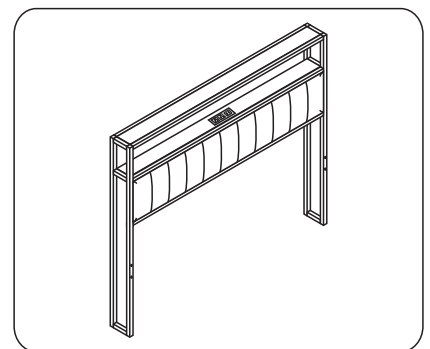
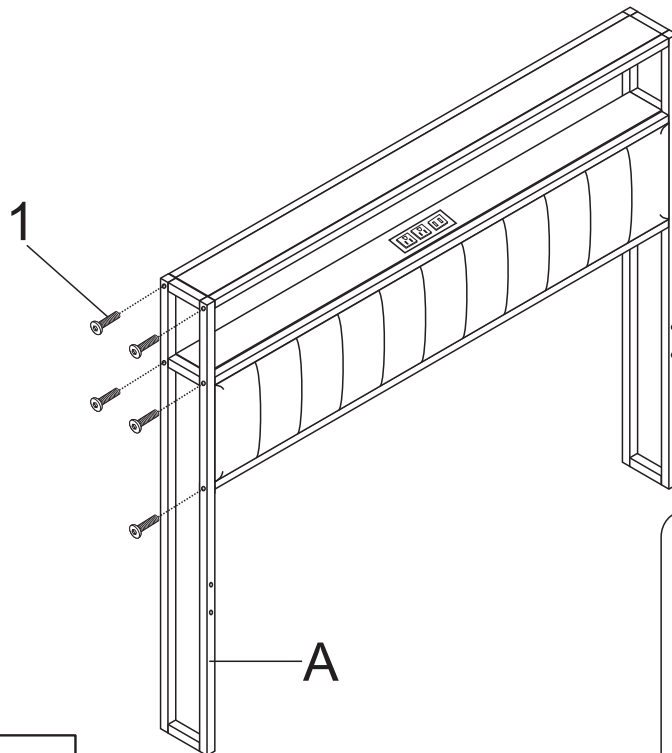

1	 M8x40mm	5PCS
---	--	------

# ASSEMBLY INSTRUCTIONS

5

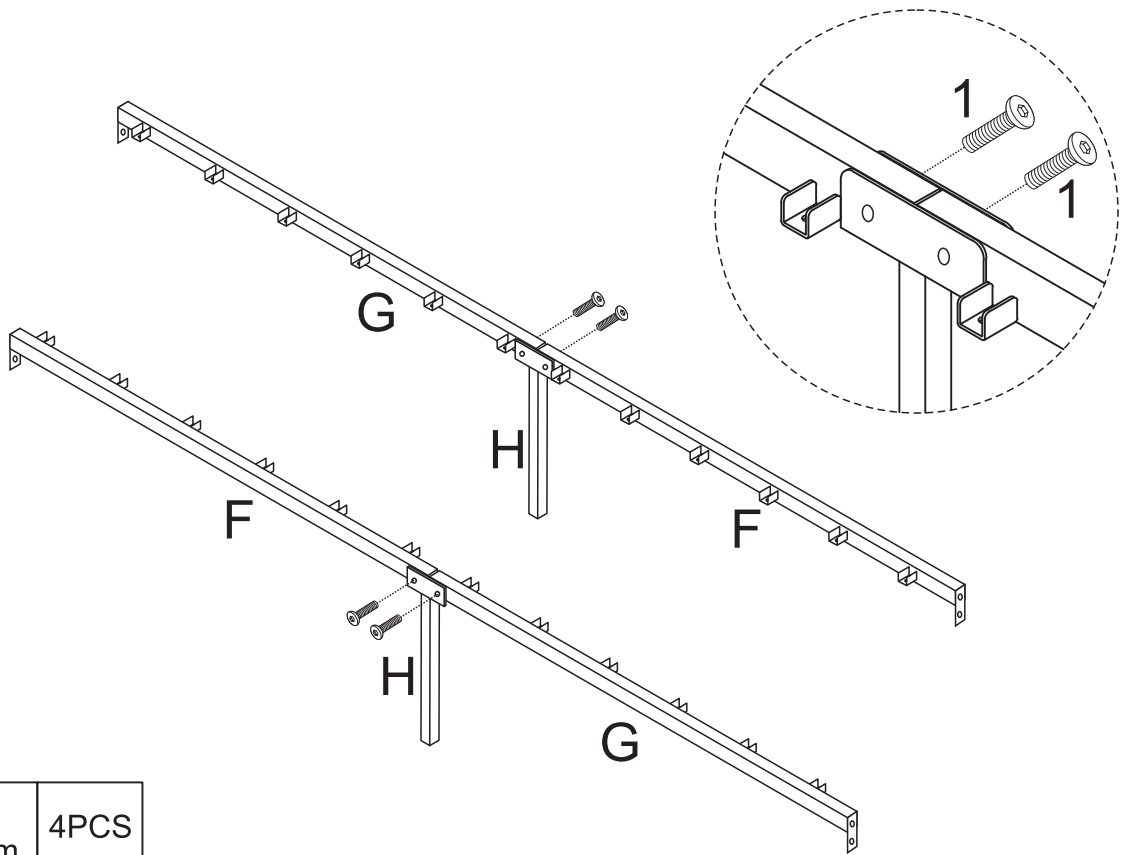

1		4PCS
	M8x40mm	

6

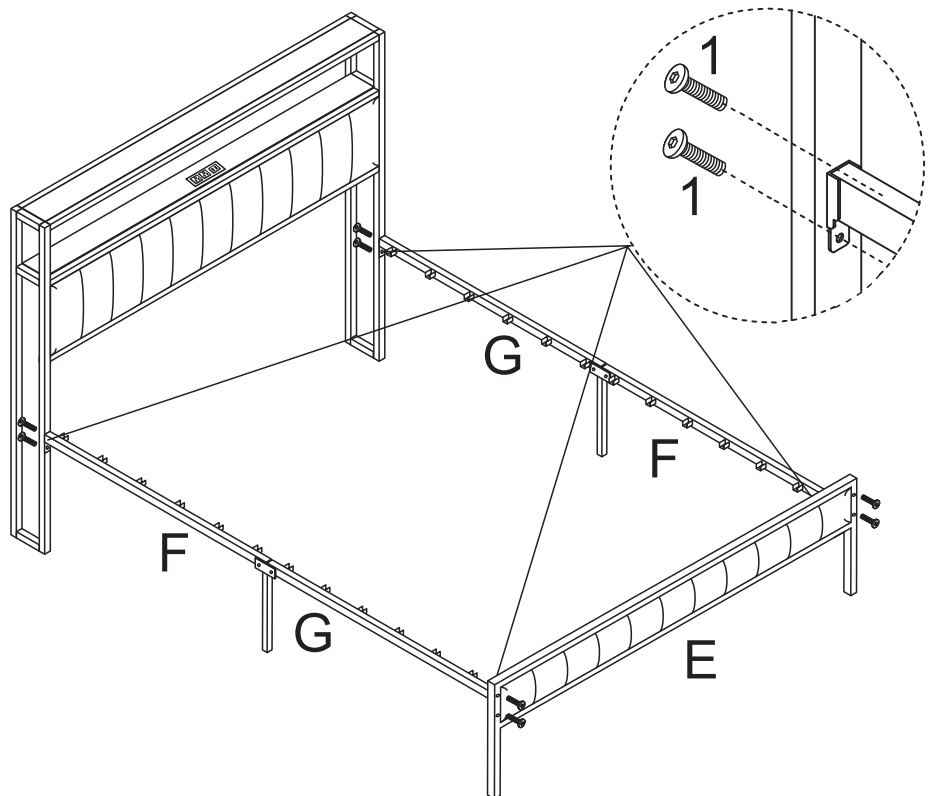

1		8PCS
	M8x40mm	

# ASSEMBLY INSTRUCTIONS

7

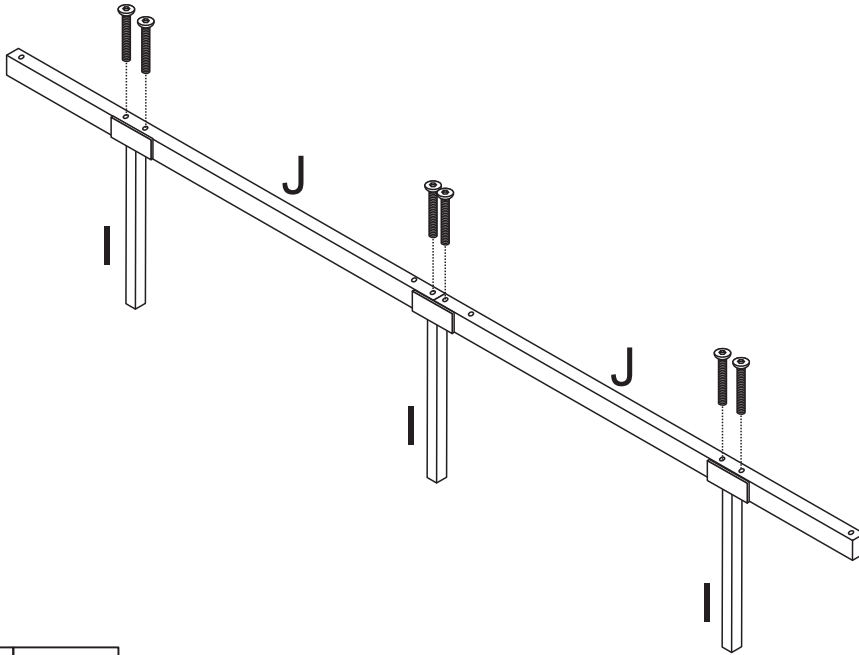

3	 M6x35mm	6PCS
---	---	------

8

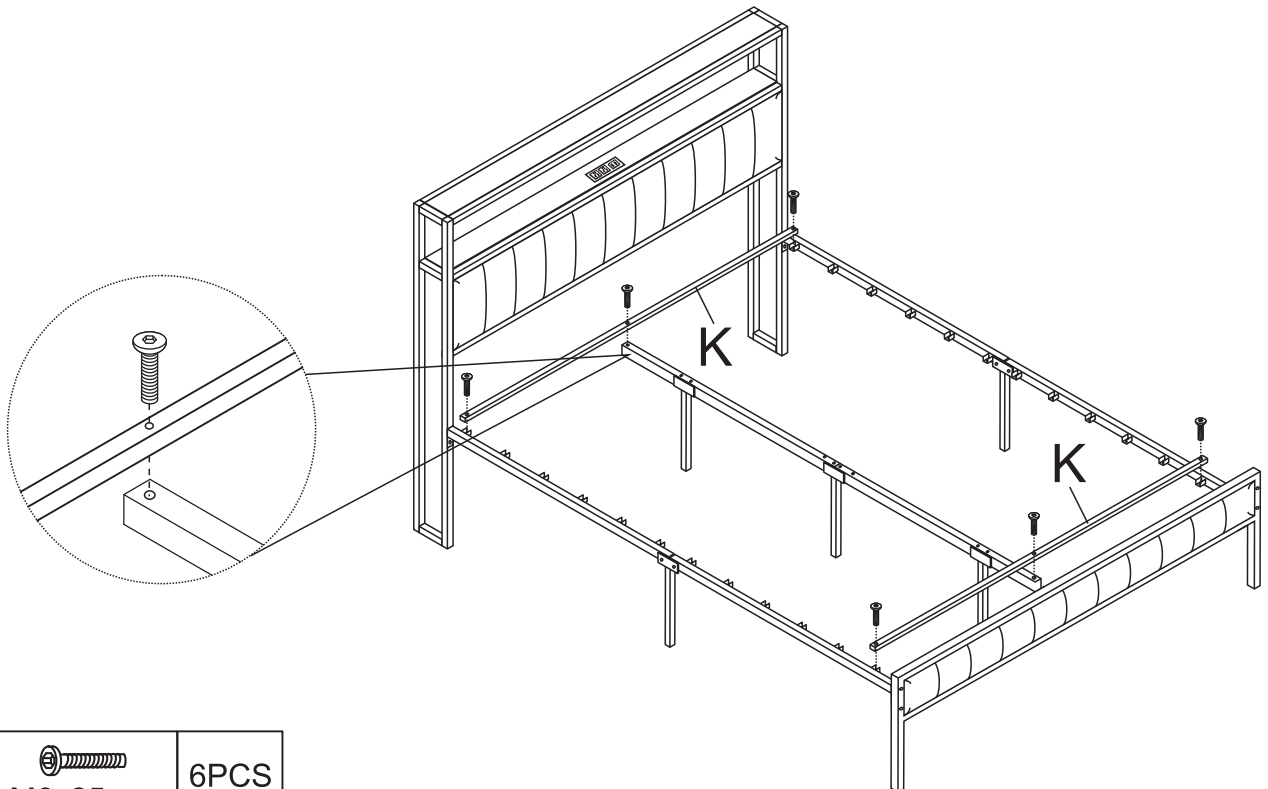

4	 M6x25mm	6PCS
---	---	------

# ASSEMBLY INSTRUCTIONS

9

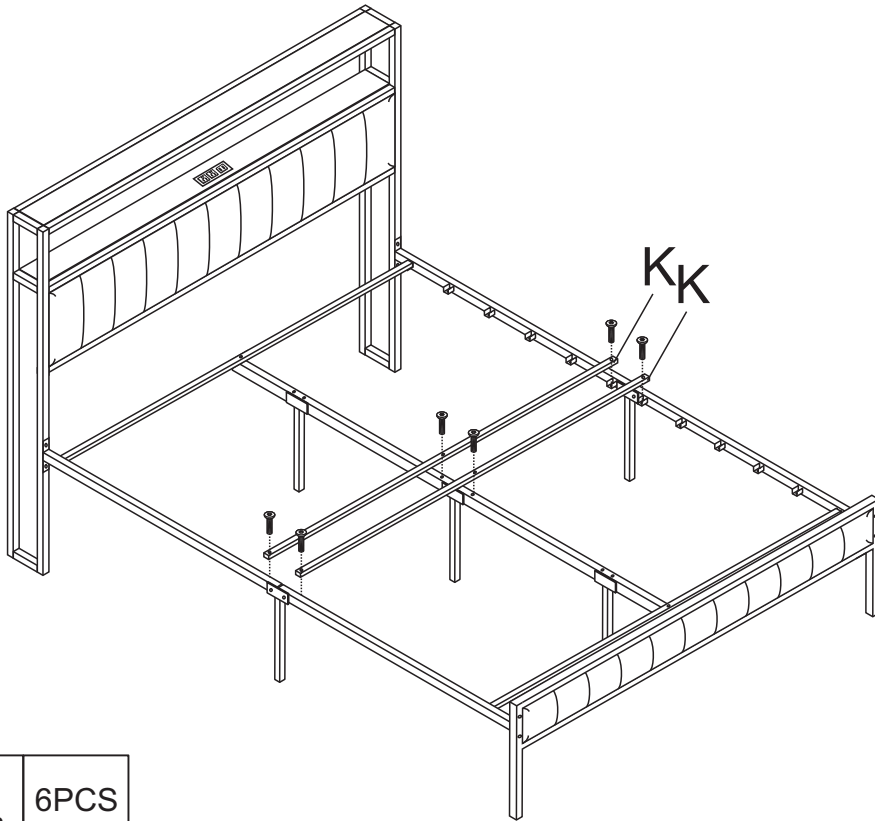

4	 M6x25mm	6PCS
---	--	------

10

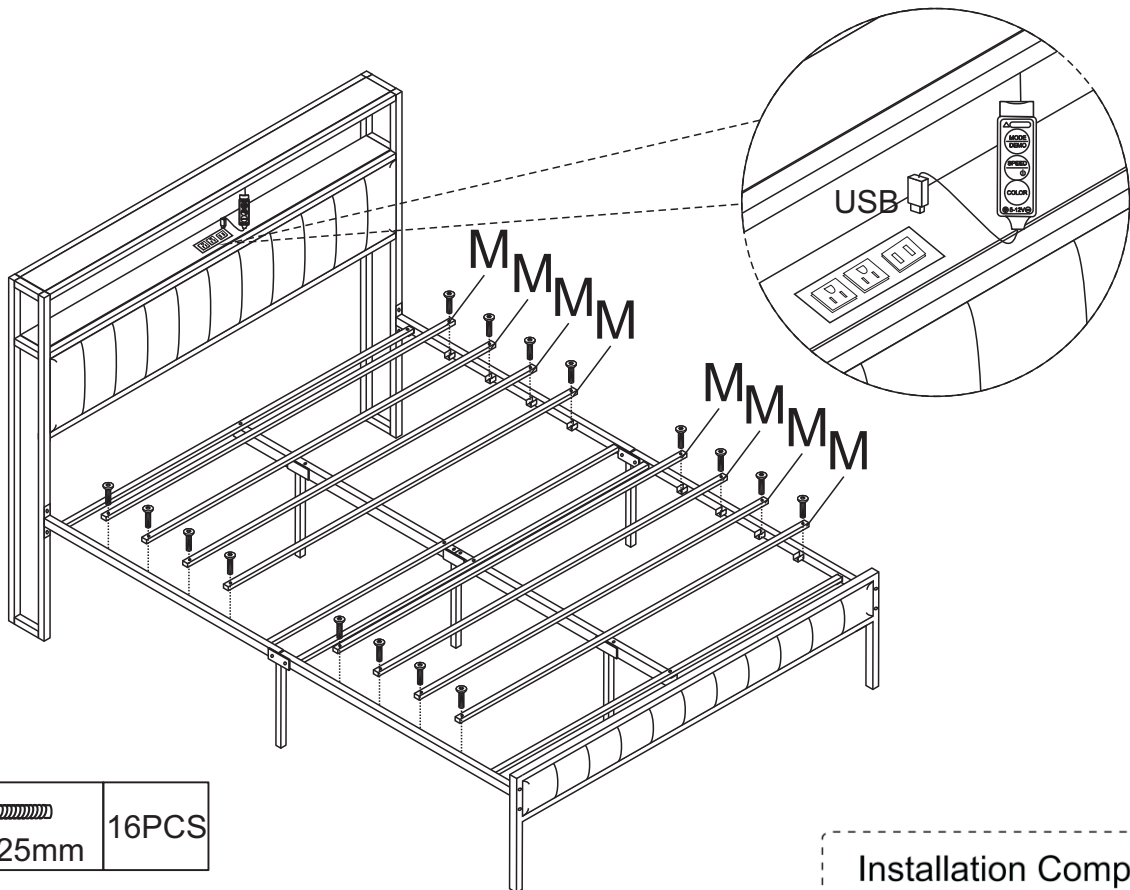

4	 M6x25mm	16PCS
---	--	-------

Installation Complete

11

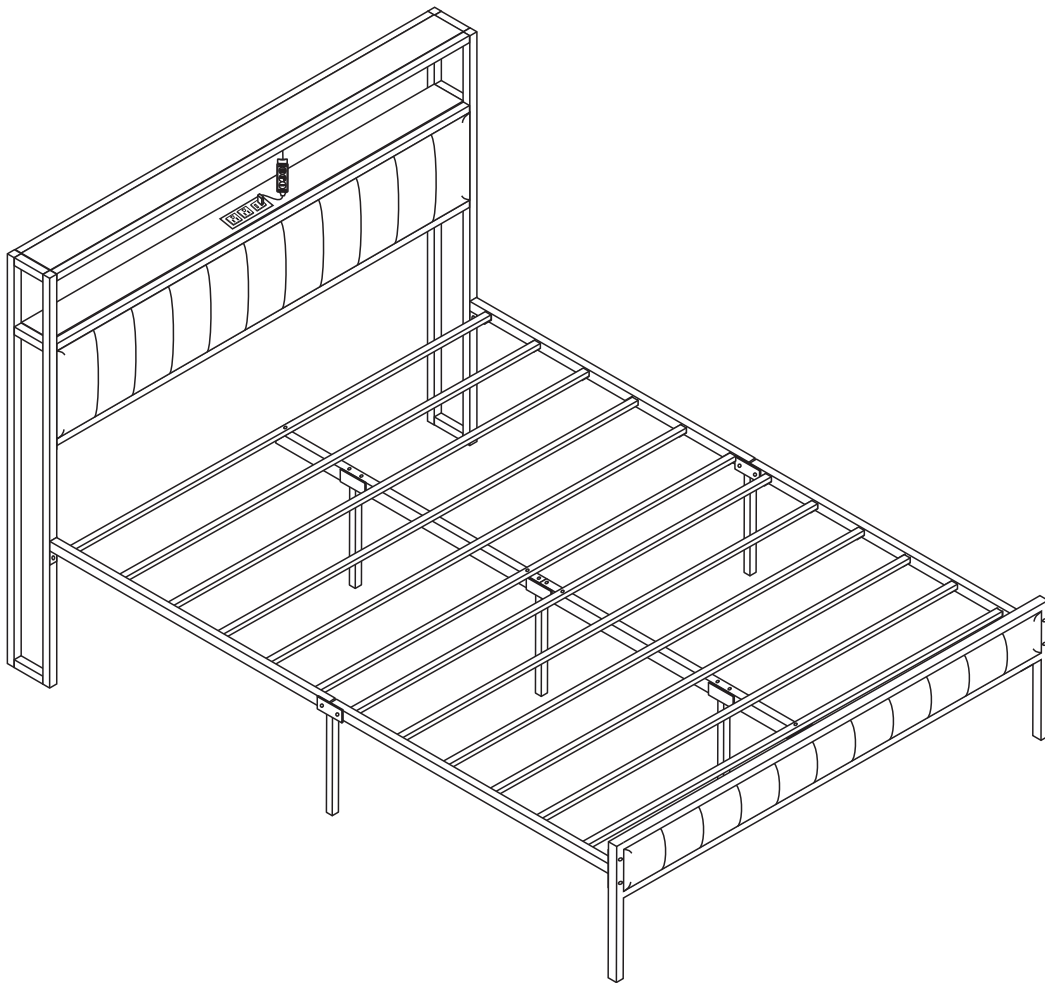

Installation Complete

# Operation Instructions of Controller

## I .Specifications:

Working temperature:-20-60°C

Supply voltage:DC5–12V

Product size:Length 50cm

Package size:9cm\*13cm

Net weight:16g

Gross weight:20g

Output:Three CMOS drain-open output

Connecting Mode:Common anode

Max load current:2 A each color

## II .Control Method:

It adopts an integrated button control,including 3buttons,and the functions of each button are as follows:

①MODE key dynamic mode:Press for the first time to switch to dynamic mode,and continus to tap to switch between flashing modes,with a total of 19 flashing effects.

②SPEED key:The button function includes pressing and holding for 1 second to power off, and clicking to turn on the power.In flashing mode,you can tap the button to adjust the speed,ang in static color mode,you can tap the button to adjust the brightness.

③COLOR KEY:Static single color switching,which contains 20 color choices,in this state press the SPEED key to adjust the brightness of the light.

## III .Panel specification and connecting drawing as follows;

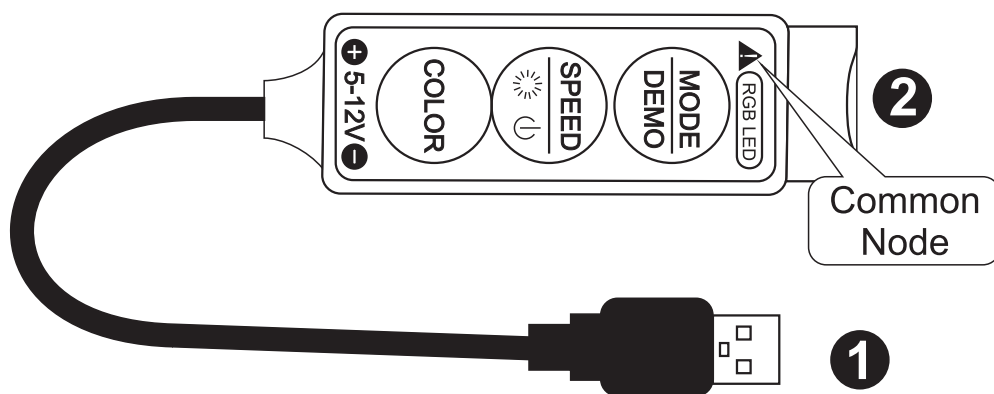

## IV .Warning:

- 1.The power connection of this product is DC5-12V,and 24v or Ac220 cannot be used.
- 2.Never connect two wires directly in case of short circuit.
- 3.Lead wire should be connected correctly according to colors that connecting diagram offers.