

PARTS LIST

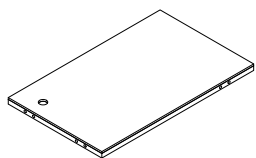

1 X1

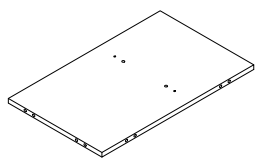

2 X1

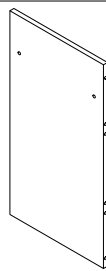

3 X1

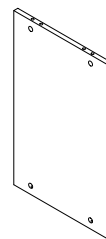

4 X1

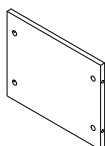

5 X1

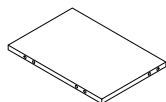

6 X1

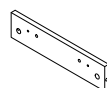

7 X1

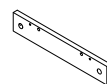

8 X3

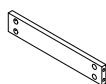

9 X1

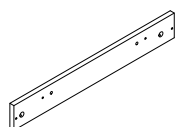

10 X1

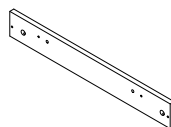

11 X1

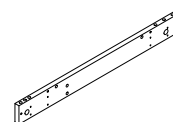

12 X1

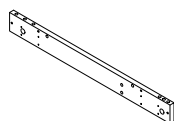

13 X1



14 X2

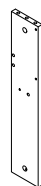

15 X1



16 X2

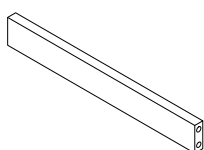

17 X1



18 X4

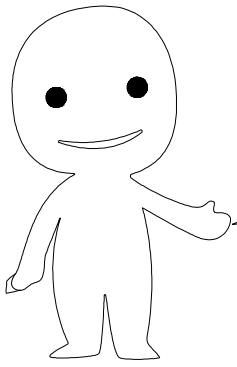

Please prepare the following tools

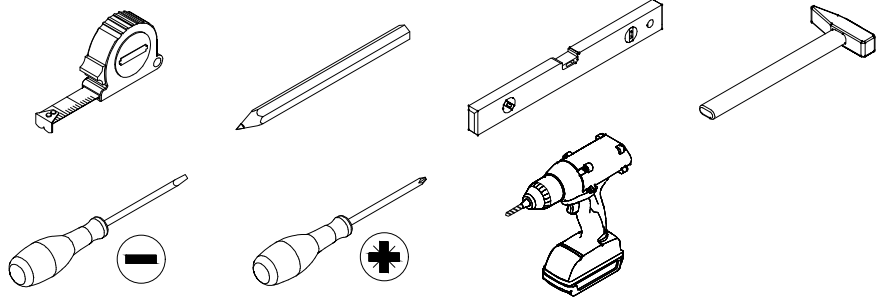

A 56 PCS

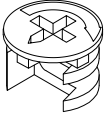

Ø15 x 12 mm

B 40 PCS

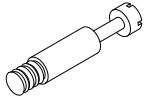

Ø7 x 35 mm

C 8 PCS

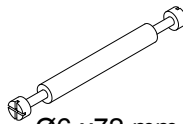

Ø6 x 72 mm

D 52 PCS

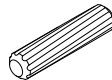

Ø8 x 30 mm

E 56 PCS

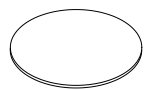

F 2 PCS

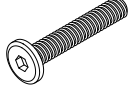

M6 x 30

M 16 PCS



Ø3.5 x 25

N 12 PCS

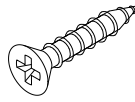

Ø4 x 16

Q 2 PCS

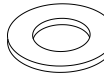

Ø6 -15 mm

Z 1 PC

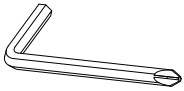

4mm

U 1 PCS

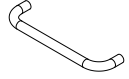

300x 70x20mm

V 2 PCS

Without brakes

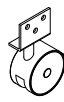

W 2 PCS

Equipped with brakes



Tips: The number after "+" represents the spare hardware.

1

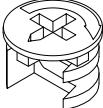
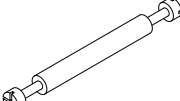
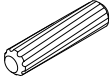
| | | | | | |
|---|--------|---|-------|---|--------|
| A | 16 PCS | C | 8 PCS | D | 16 PCS |
|  | |  | |  | |
| Ø15 x 12 mm | | Ø6 x72 mm | | Ø8 x30 mm | |

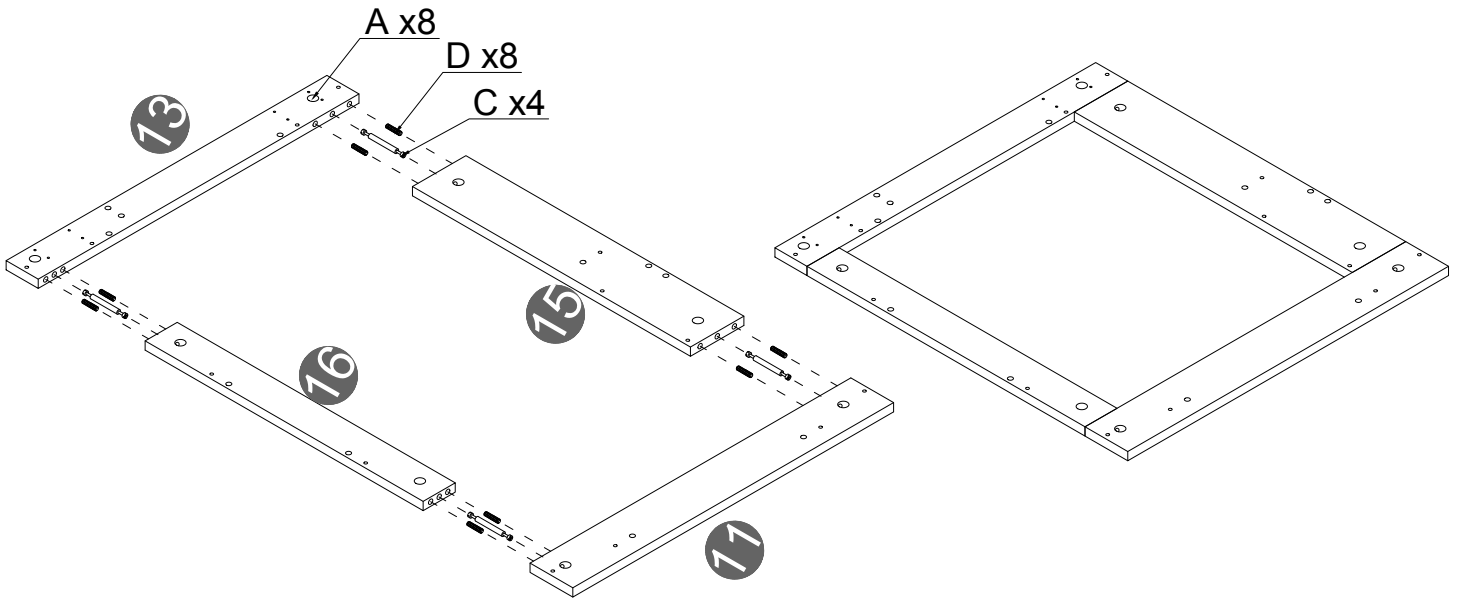
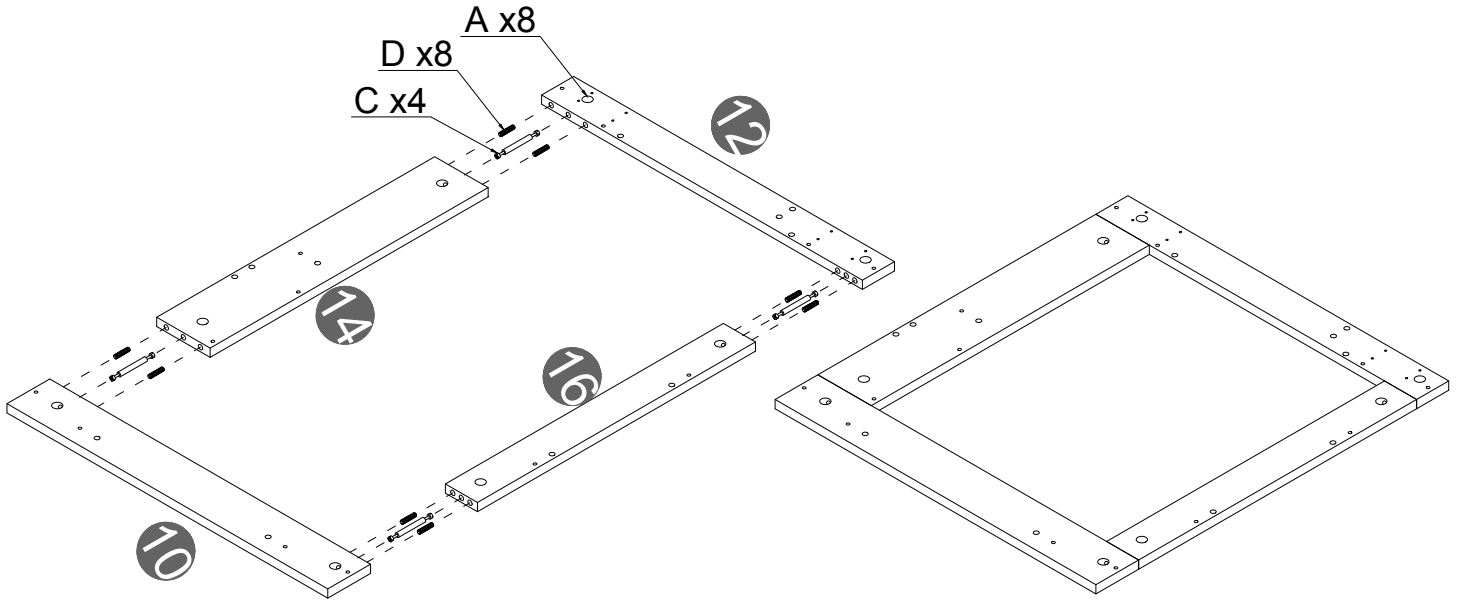

Cam Lock/Dowel Placement Supplement

CORRECT

1

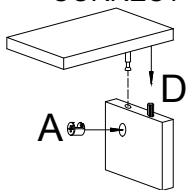

When inserting the Cam lock, make sure that the open End of the cam Lock faces the Cam Screw Entry. The Dowel will be inserted in the hole NEXT to the Cam Lock/Cam Screw hole.

INCORRECT

2

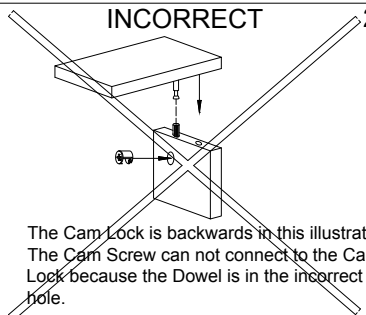

The Cam Lock is backwards in this illustration. The Cam Screw can not connect to the Cam Lock because the Dowel is in the incorrect hole.

3

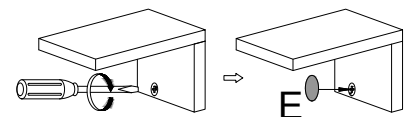

To tighten, turn the Cam Lock CLOCKWISE until the arrow or "△" signs point AWAY from the connected Panel.

***NOTE: DO NOT USE AN AUTOMATIC SCREWDRIVER TO TIGHTEN CAM LOCKS, DO NOT OVER-TIGHTEN.**

2

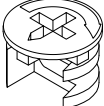
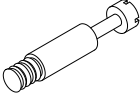
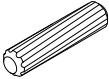
| A | 4 PCS | B | 4 PCS | D | 4 PCS |
|---|-------|---|-------|---|-------|
|  | |  | |  | |
| Ø15 x 12 mm | | Ø7 x 35 mm | | Ø8 x 30 mm | |

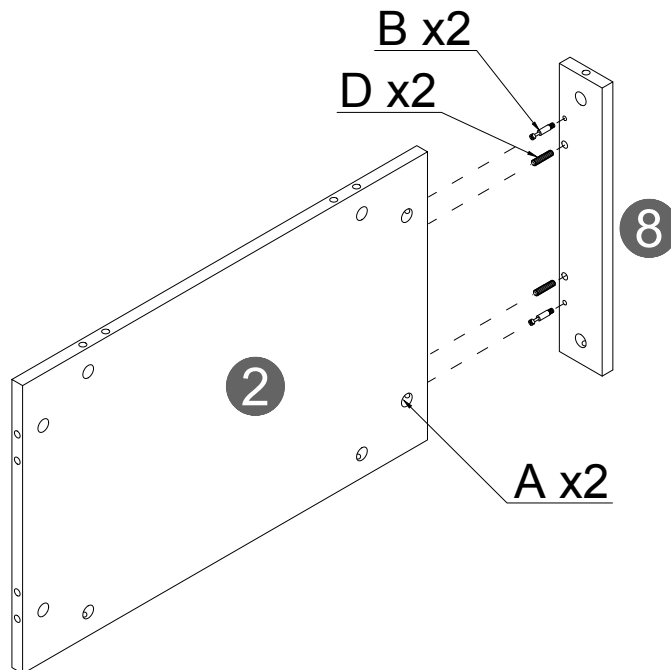
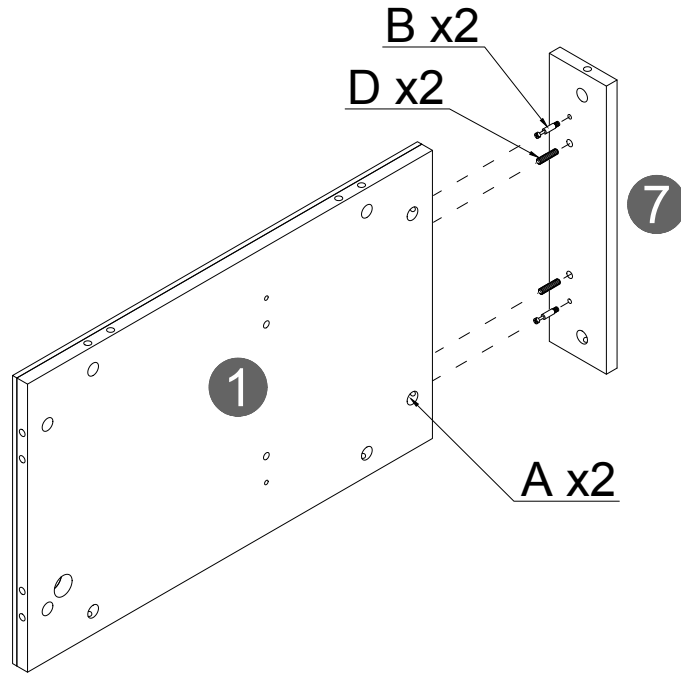
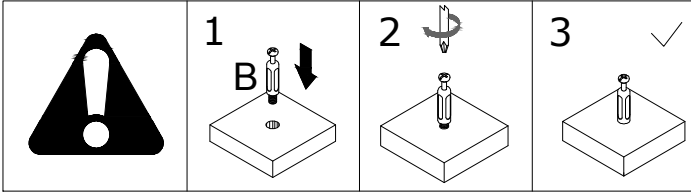



| A | 4 PCS | B | 4 PCS | D | 4 PCS |
|-------------|-------|------------|-------|------------|-------|
| | | | | | |
| Ø15 x 12 mm | | Ø7 x 35 mm | | Ø8 x 30 mm | |

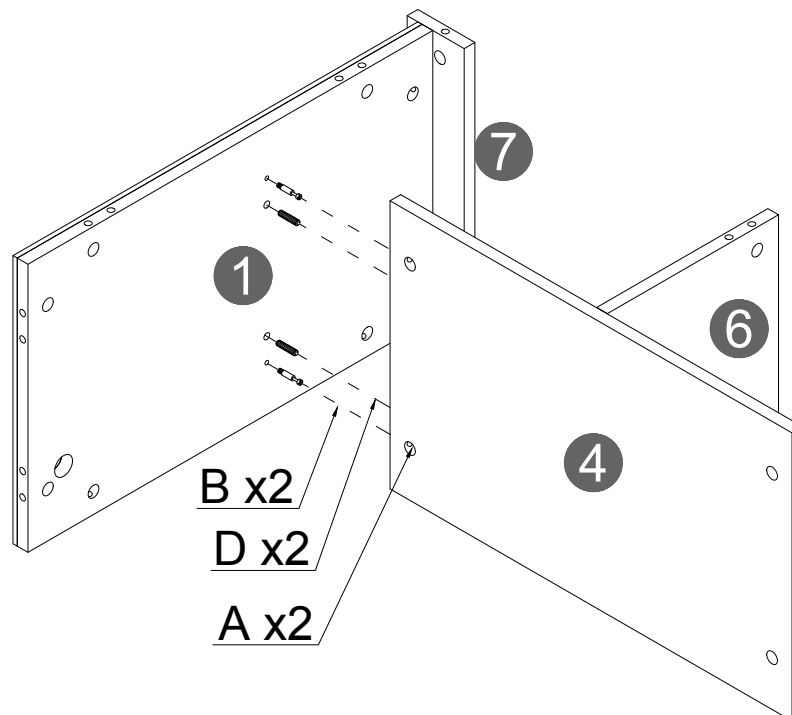
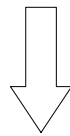
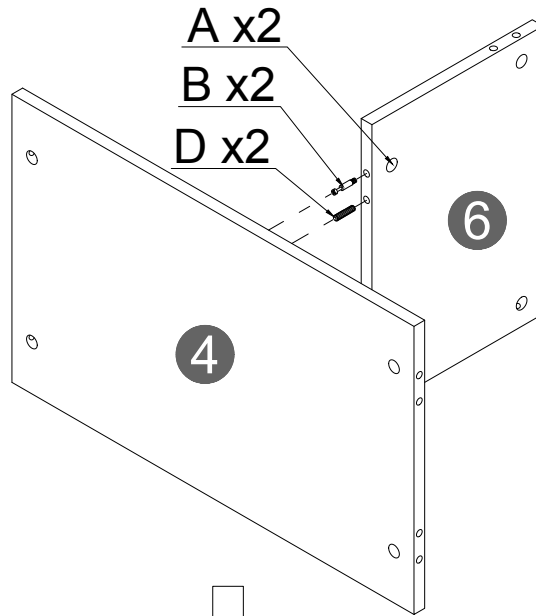
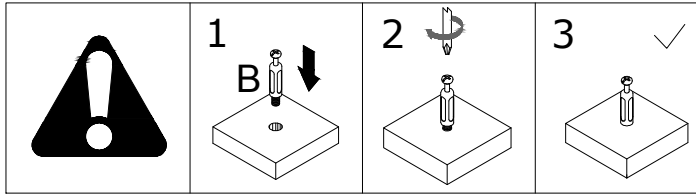

4

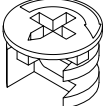
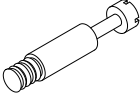
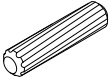
| A | 2 PCS | B | 2 PCS | D | 2 PCS |
|---|-------|---|-------|---|-------|
|  | |  | |  | |
| Ø15 x 12 mm | | Ø7 x 35 mm | | Ø8 x 30 mm | |

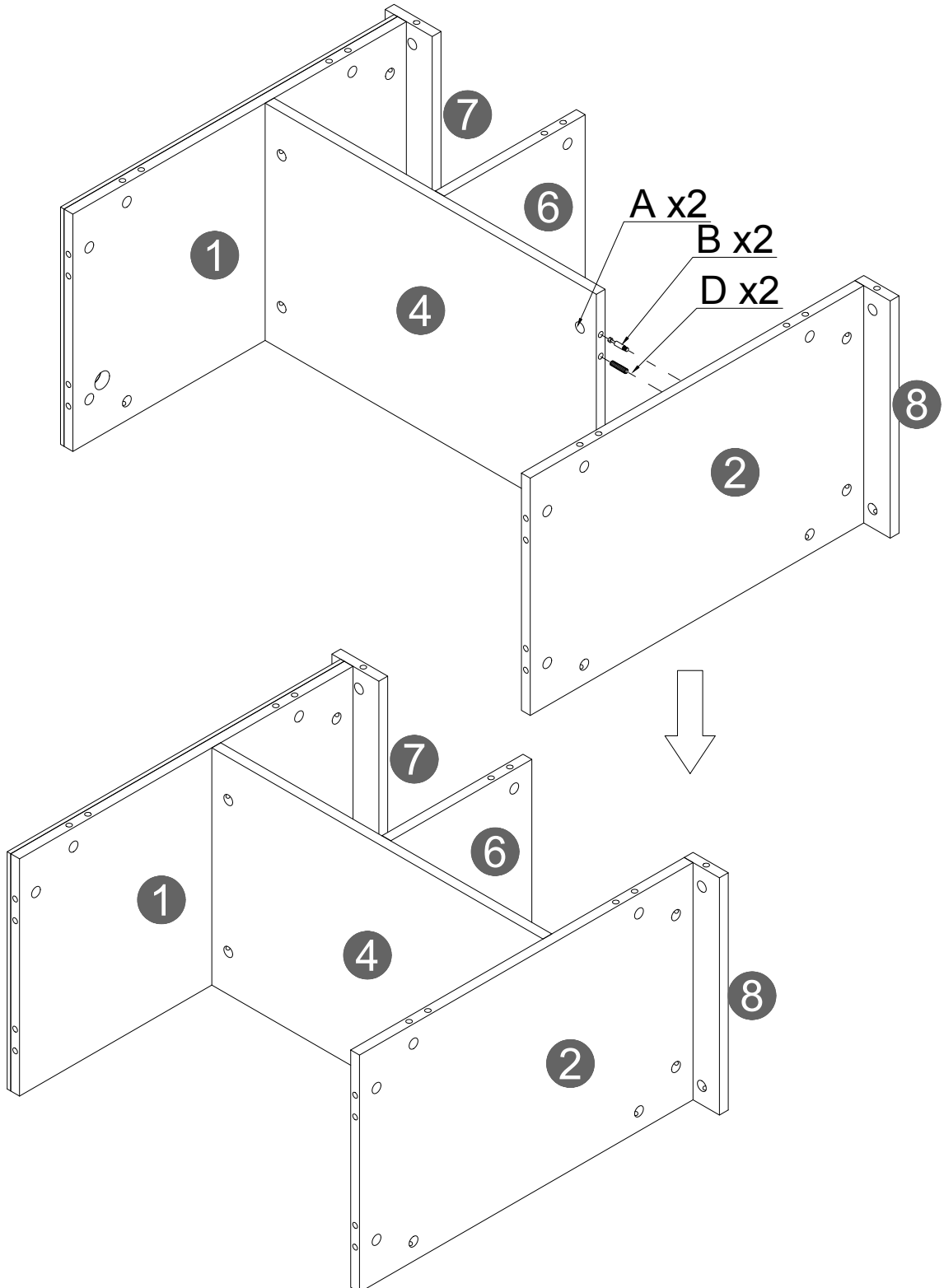
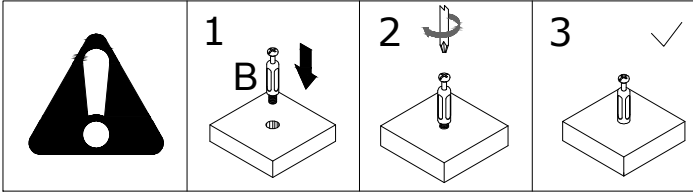

5

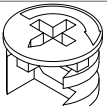
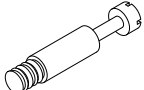
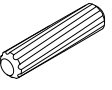
| A | 4 PCS | B | 4 PCS | D | 4 PCS |
|---|-------|---|-------|---|-------|
|  | |  | |  | |
| Ø15 x 12 mm | | Ø7 x 35 mm | | Ø8 x 30 mm | |

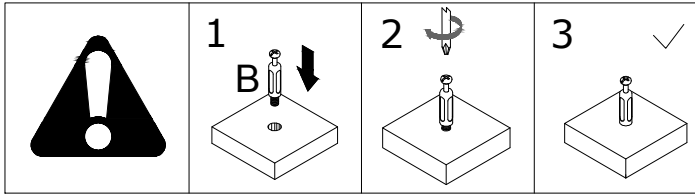

A x4
B x4
D x4

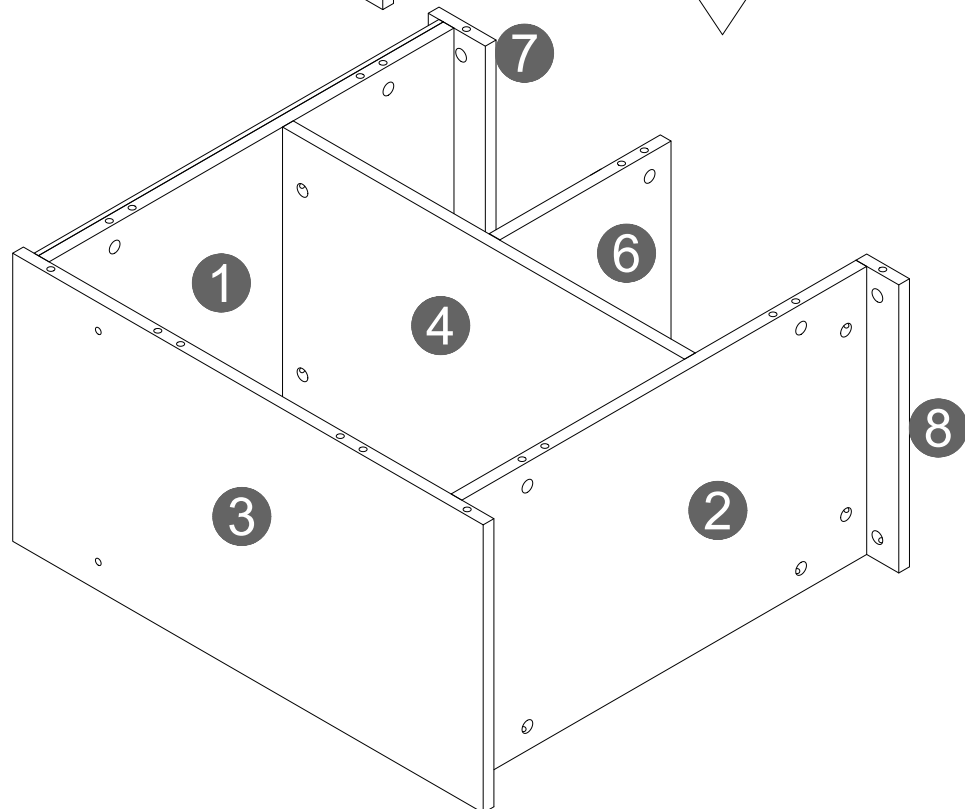
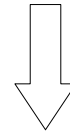
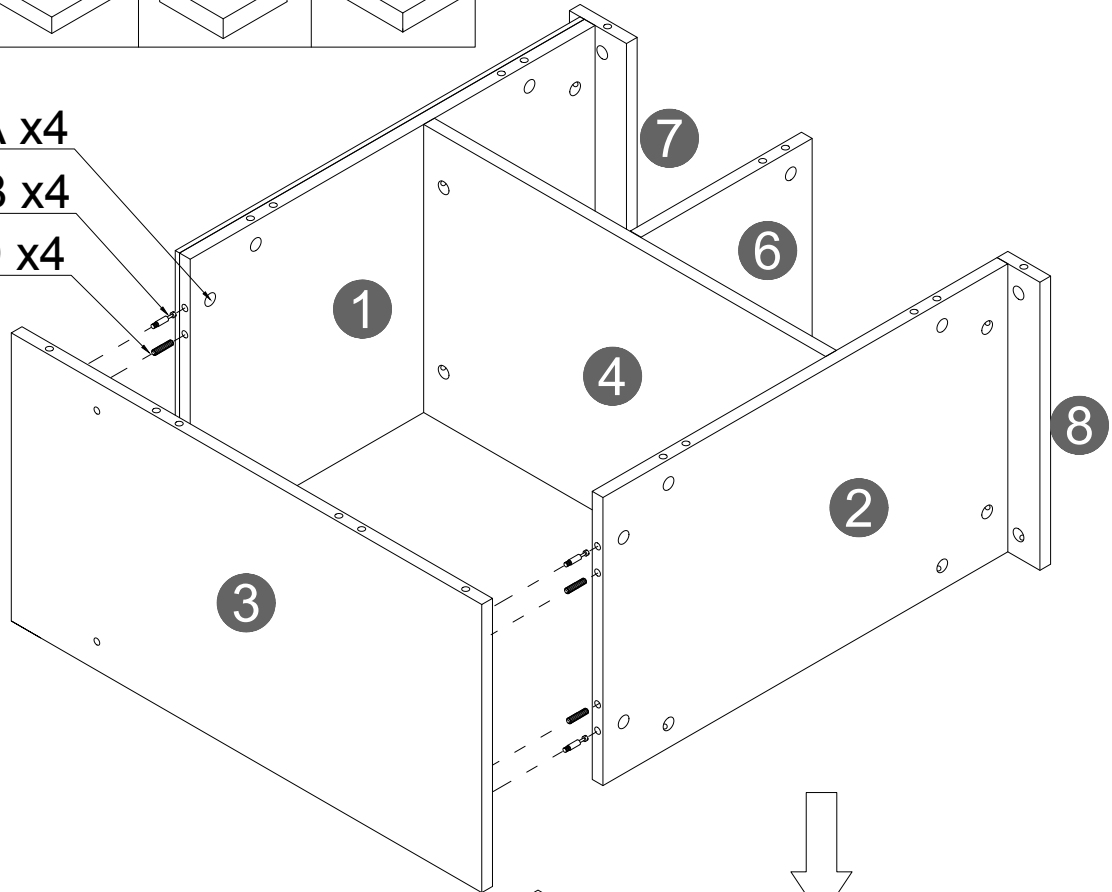



| A | 13 PCS | B | 13 PCS | D | 11 PCS |
|-------------|--------|------------|--------|------------|--------|
| | | | | | |
| Ø15 x 12 mm | | Ø7 x 35 mm | | Ø8 x 30 mm | |

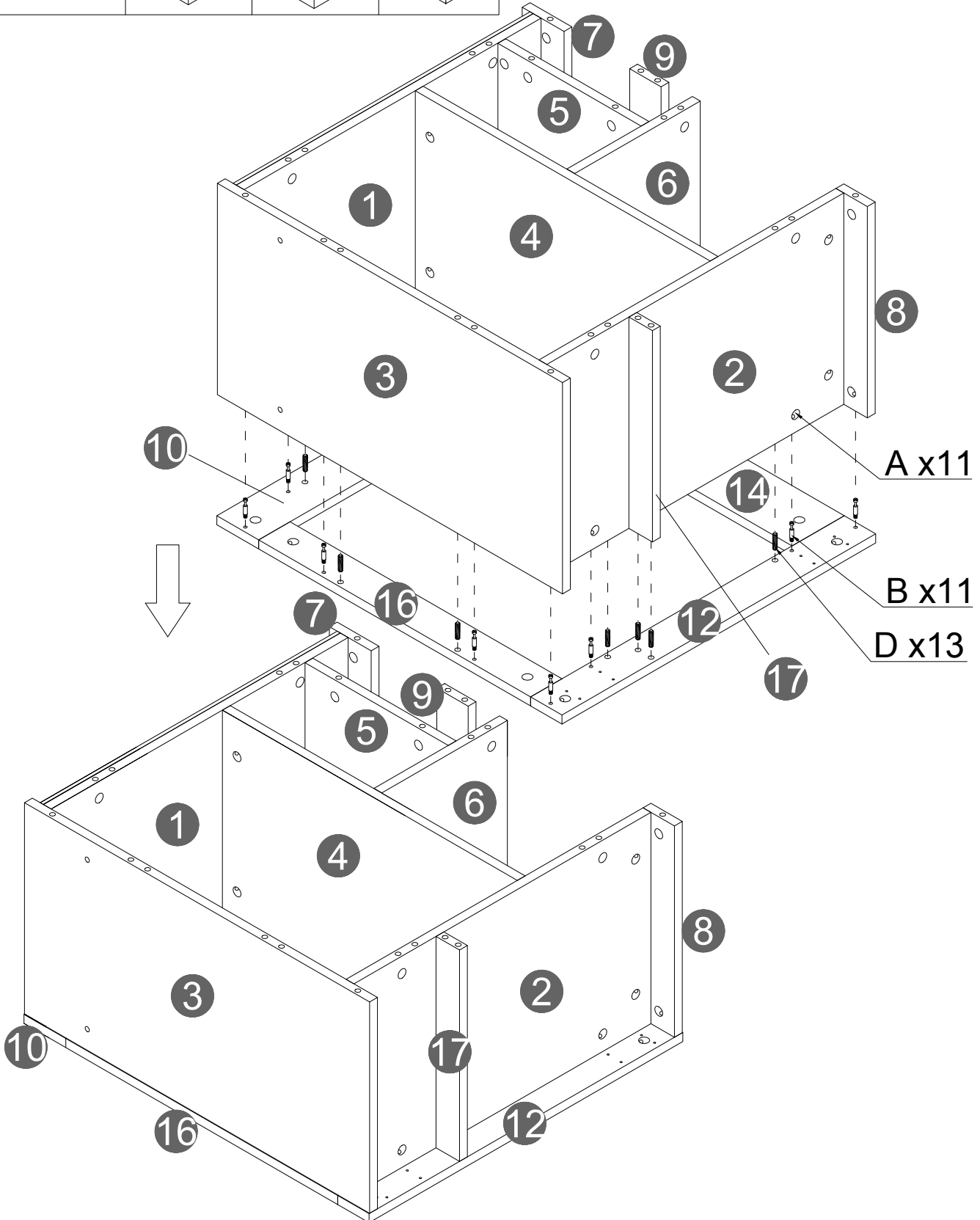
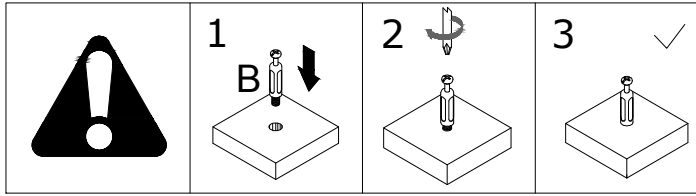





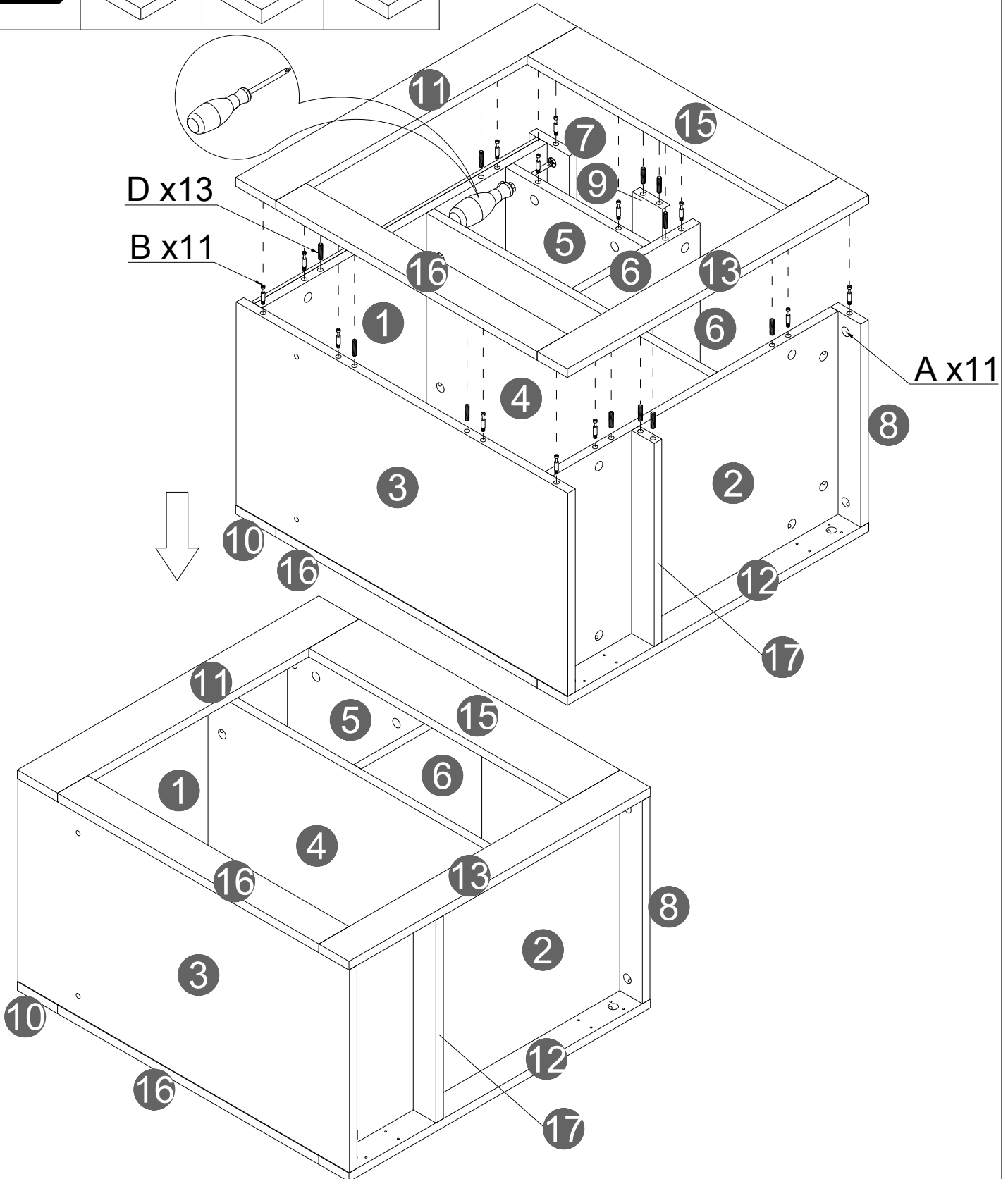
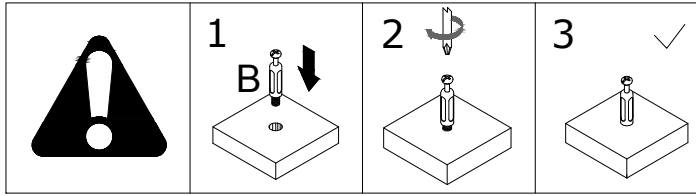

| A | 13PCS | B | 13PCS | D | 11PCS |
|-----------------------------------|-------|----------------------------------|-------|----------------------------------|-------|
| | | | | | |
| $\text{Ø}15 \times 12 \text{ mm}$ | | $\text{Ø}7 \times 35 \text{ mm}$ | | $\text{Ø}8 \times 30 \text{ mm}$ | |

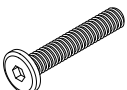

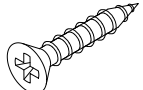

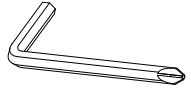
| | | | | | | | | | |
|---|-------|---|--------|---|--------|--|-------|---|------|
| F | 2 PCS | M | 16 PCS | N | 12 PCS | Q | 2 PCS | Z | 1 PC |
|  | |  | |  | |  | |  | |
| M6 x 30 | | Ø3.5 x 25 | | Ø4 x 16 | | Ø6 -15 mm | | 4mm | |

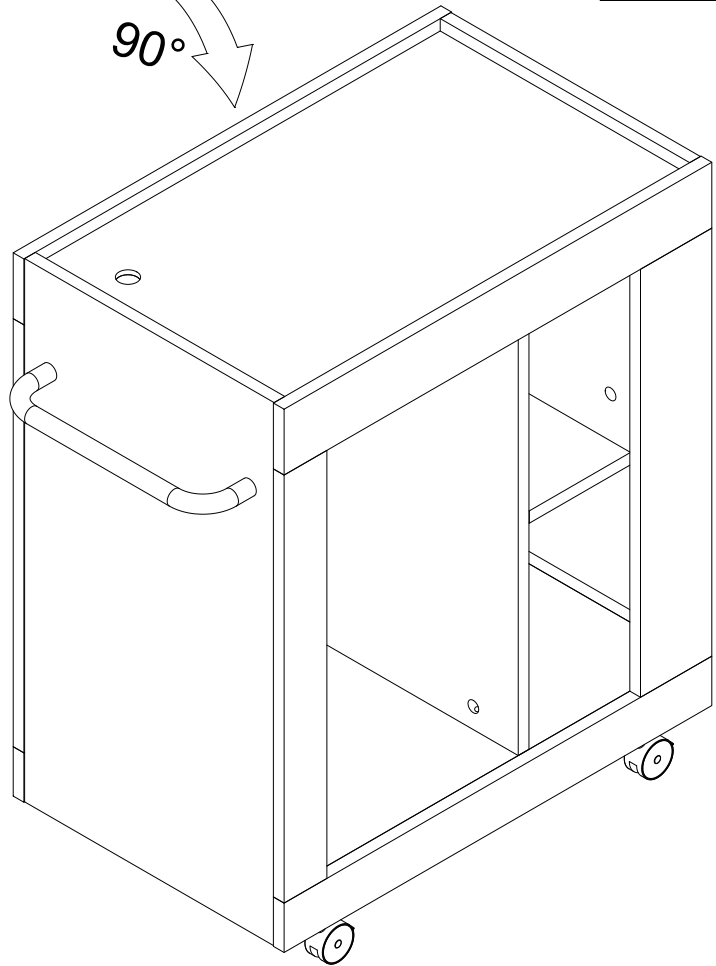
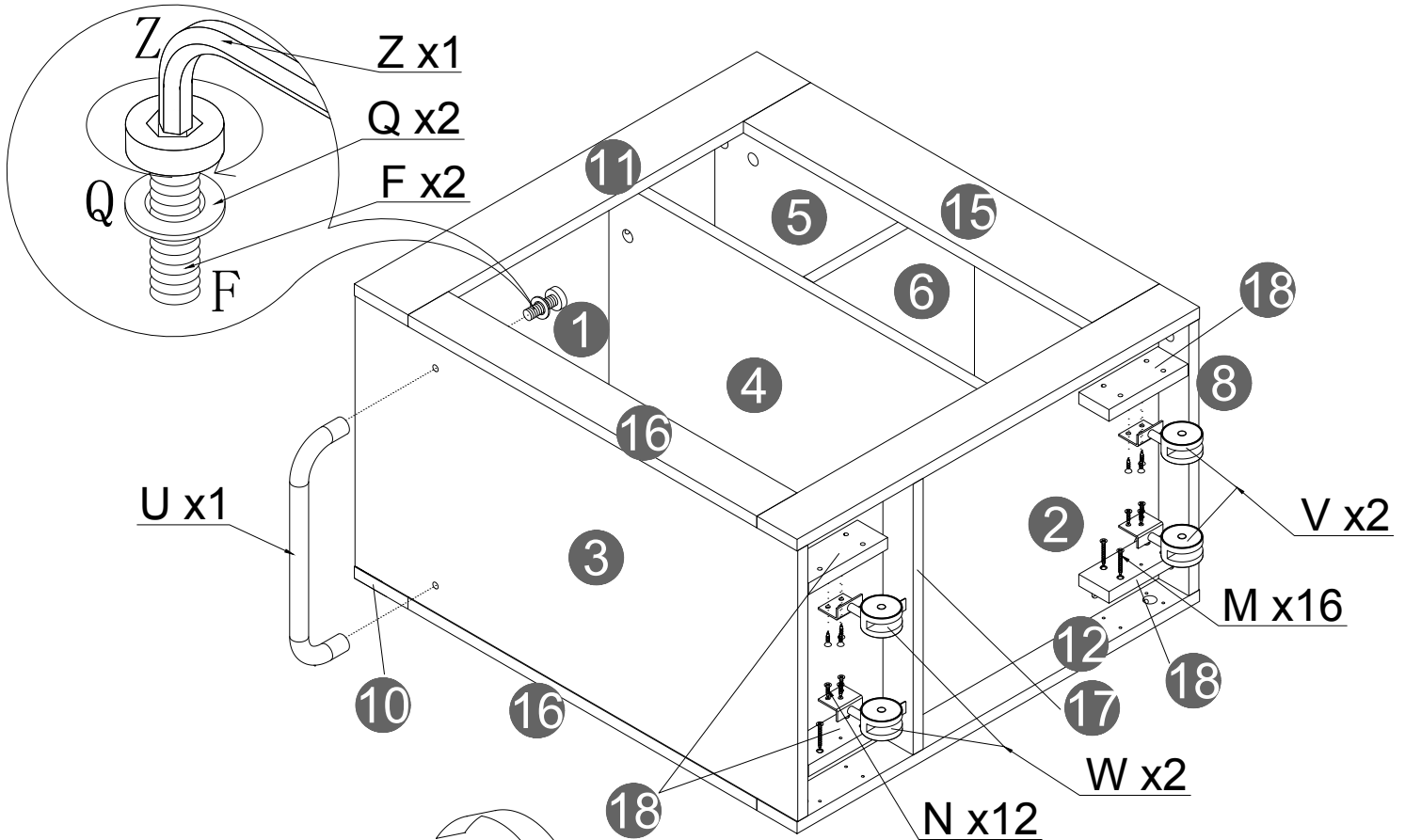

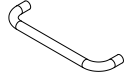
| | |
|---|-------|
| U | 1 PCS |
|  | |
| 300x 70x20mm | |

| | |
|---|-------|
| V | 2 PCS |
| Without brakes | |
|  | |

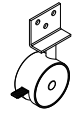
| | |
|---|-------|
| W | 2 PCS |
| Equipped with brakes | |
|  | |

