

IMPORTANT NOTE

Carefully remove all the parts from the carton and put them individually on a soft cloth to prevent scratches or other damages occurring to the parts.

We have taken great care in the design of this product and request that you carefully and strictly follow our assembly instructions to ensure a completed product as it was designed.

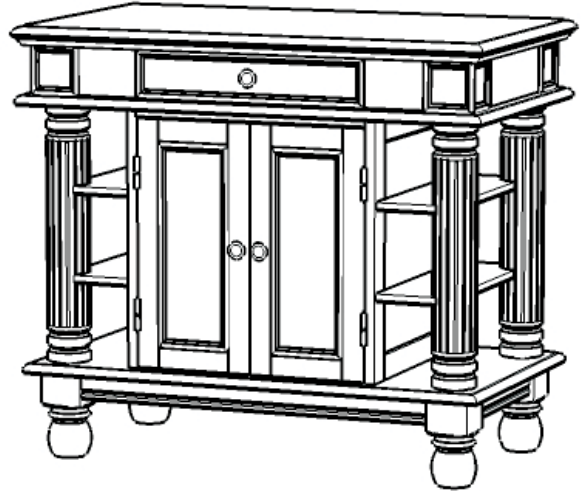

Part List

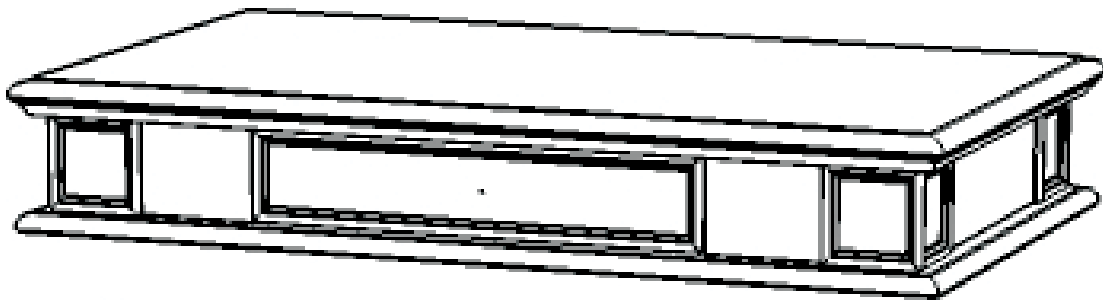

F.
Foot
4 pcs.

A.
Top
1 pc.

Hardware List



Small
Hex Wrench
1 pc.



Hex Wrench
1 pc.



Flat Washer
4 pcs.(+1 extra)



Adjustable Pin
4 pcs. (+2 extra)



Cam Lock
4 pcs.(+1 extra)

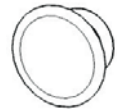

Pull Handle
6 pcs.



Head Cap Bolt
16 pcs. (+1 extra)



Head Cap Bolt (long)
4 pcs. (+1 extra)



Spring Washer
4 pcs.(+1 extra)

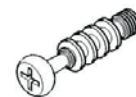

Cam Lock Screw
4 pcs.(+1 extra)



Machine Screw
6 pcs.

Tools required for assembly : **Phillips** screwdriver

IMPORTANT NOTE

Carefully remove all the parts from the carton and put them individually on a soft cloth to prevent scratches or other damages occurring to the parts.

We have taken great care in the design of this product and request that you carefully and strictly follow our assembly instructions to ensure a completed product as it was designed.

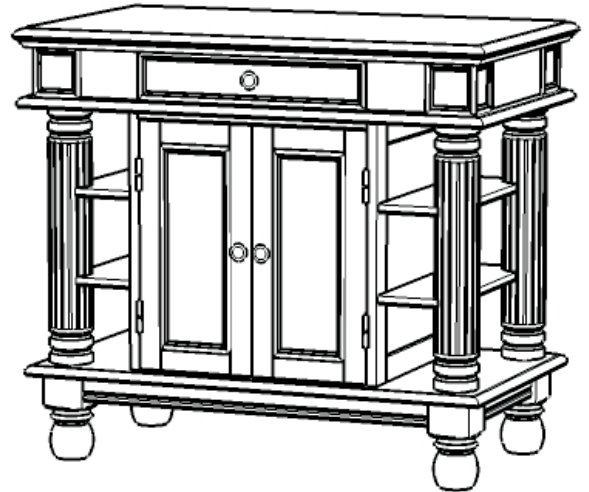

Part List



B. Rail
2 pcs.



D. Leg
2 pcs.



E. Leg
2 pcs.

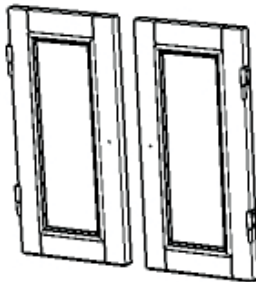

H. Door
2 pcs.

I. Door
2 pcs.

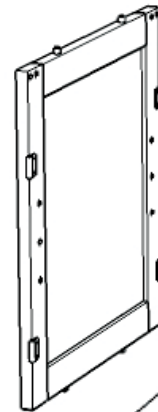

C. Side Panel
2 pcs.



G. Shelf
4 pcs.



J. Shelf
1 pc.

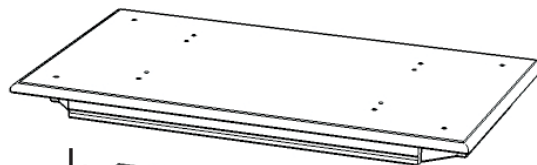

K. Base
1 pc.

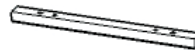

L. Stretcher
2 pcs.

Also need the following from carton

Part List in carton

Top (A)	1 pc.
Foot (F)	4 pcs.

Hardware List in carton

Hex Wrench	1 pc.
Small Hex Wrench	1 pc.
Cam Lock Screw	5 pcs.
Cam Lock	5 pcs.
Head Cap Bolt	17 pcs.
Head Cap Bolt (long)	5 pcs.
Spring Washer	5 pcs.
Flat Washer	5 pcs.
Adjustable Pin	6 pcs.
Pull Handle	8 pcs.
Machine Screw	8 pcs.

Tools required for assembly : **Phillips** screwdriver

Assembly Instructions 3/5

IMPORTANT

* Do not tighten up all the screws until each part is properly assembled.

* You should keep Hex Wrench in a safe place as you may need to tighten up the Head Cap Bolts in the future.

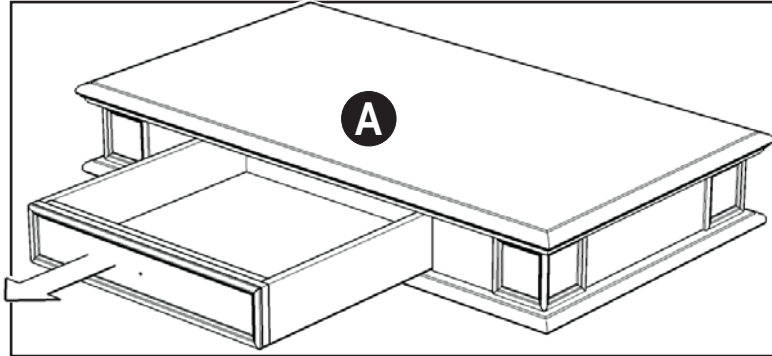

STEP 1

Remove the Drawer from Top (A).

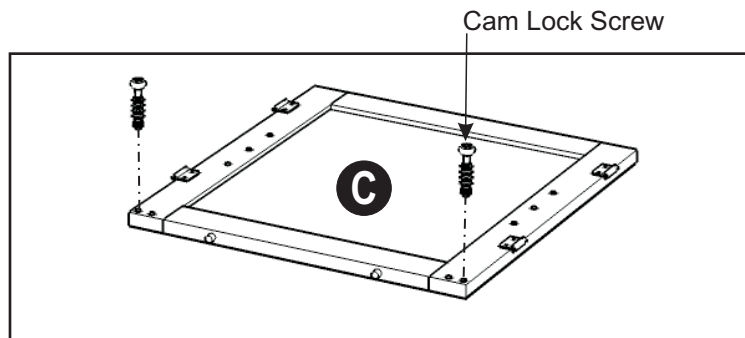

Figure 1

STEP 2

Put Cam Lock Screws into the pre-drilled holes of Side Panels (C) and tighten. (see Figure 1)

Assemble Side Panel (C) and Rail (B) using Cam Lock. (see Figure 2)

Place the unit onto Top (A).

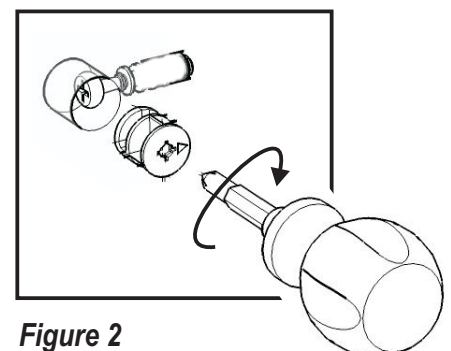
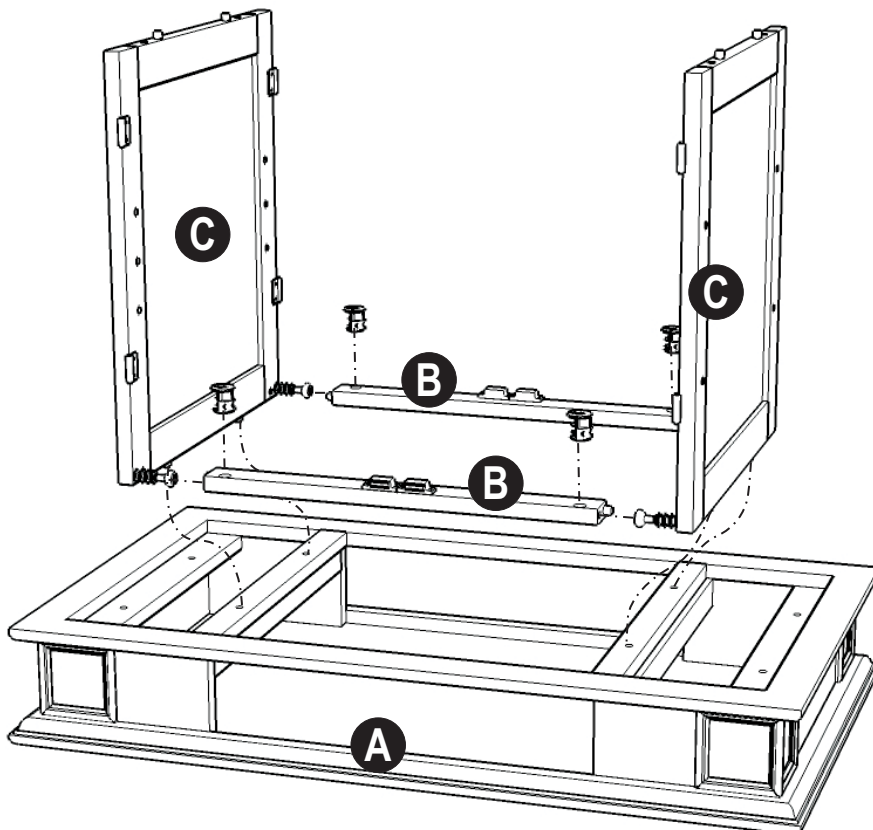

Figure 2

STEP 3

Attach Rail (L) to Leg (D) and (E) with Head Cap Bolts. (see Figure 3)

Attach Shelf (G) to unit at the pre-drill holes of side panels, then, attach the assembled legs to unit with Head Cap Bolts.

Head Cap Bolt

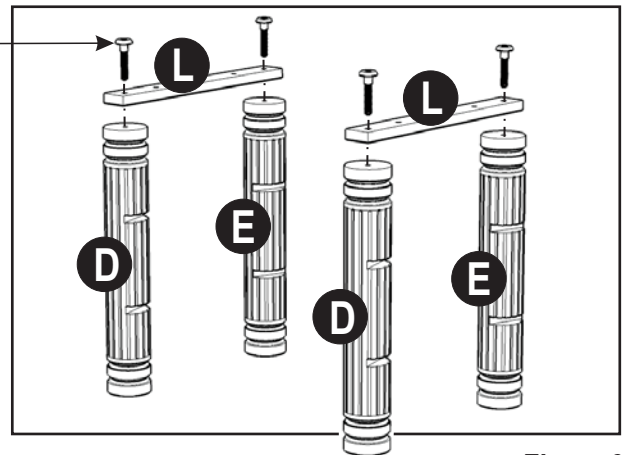
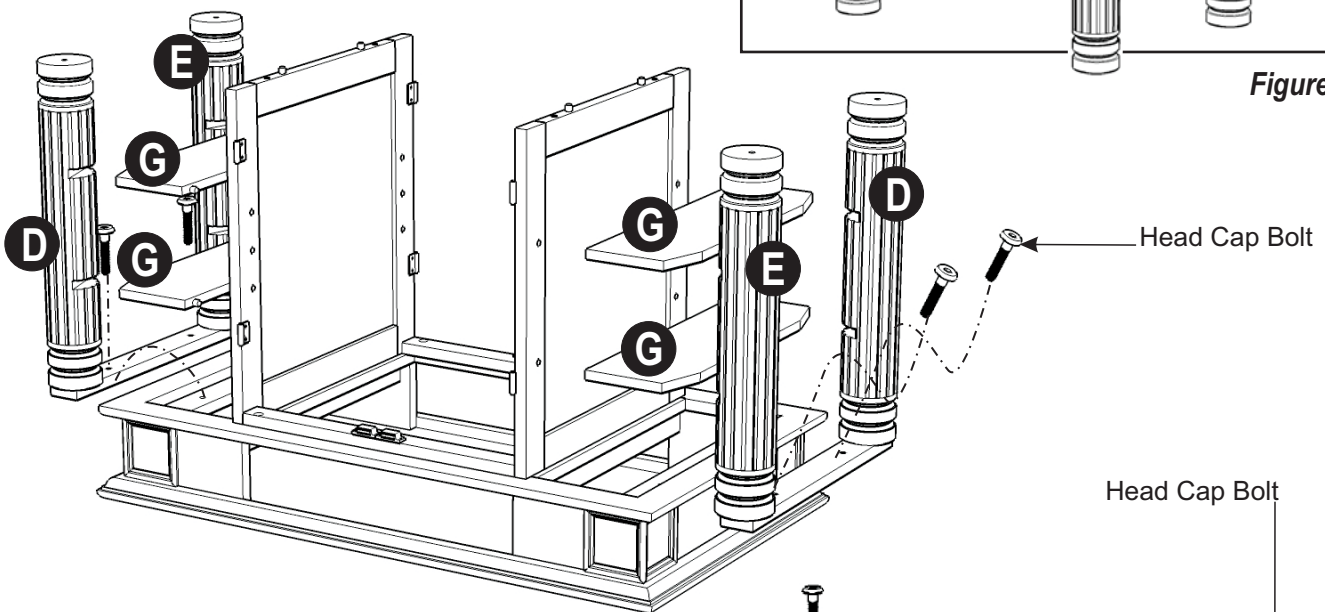
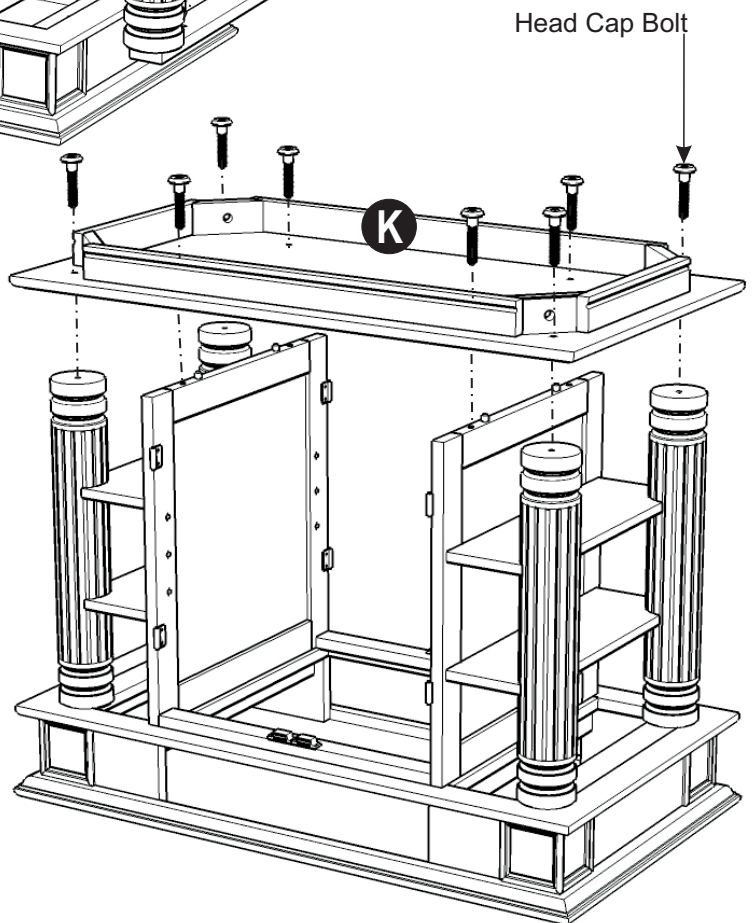

Figure 3



STEP 4

Attach Base (K) to unit with Head Cap Bolts.



STEP 5

Attach Feet (F) to Base (K) with Head Cap Bolts, Spring Washers and Flat Washers. (see Figure 4)

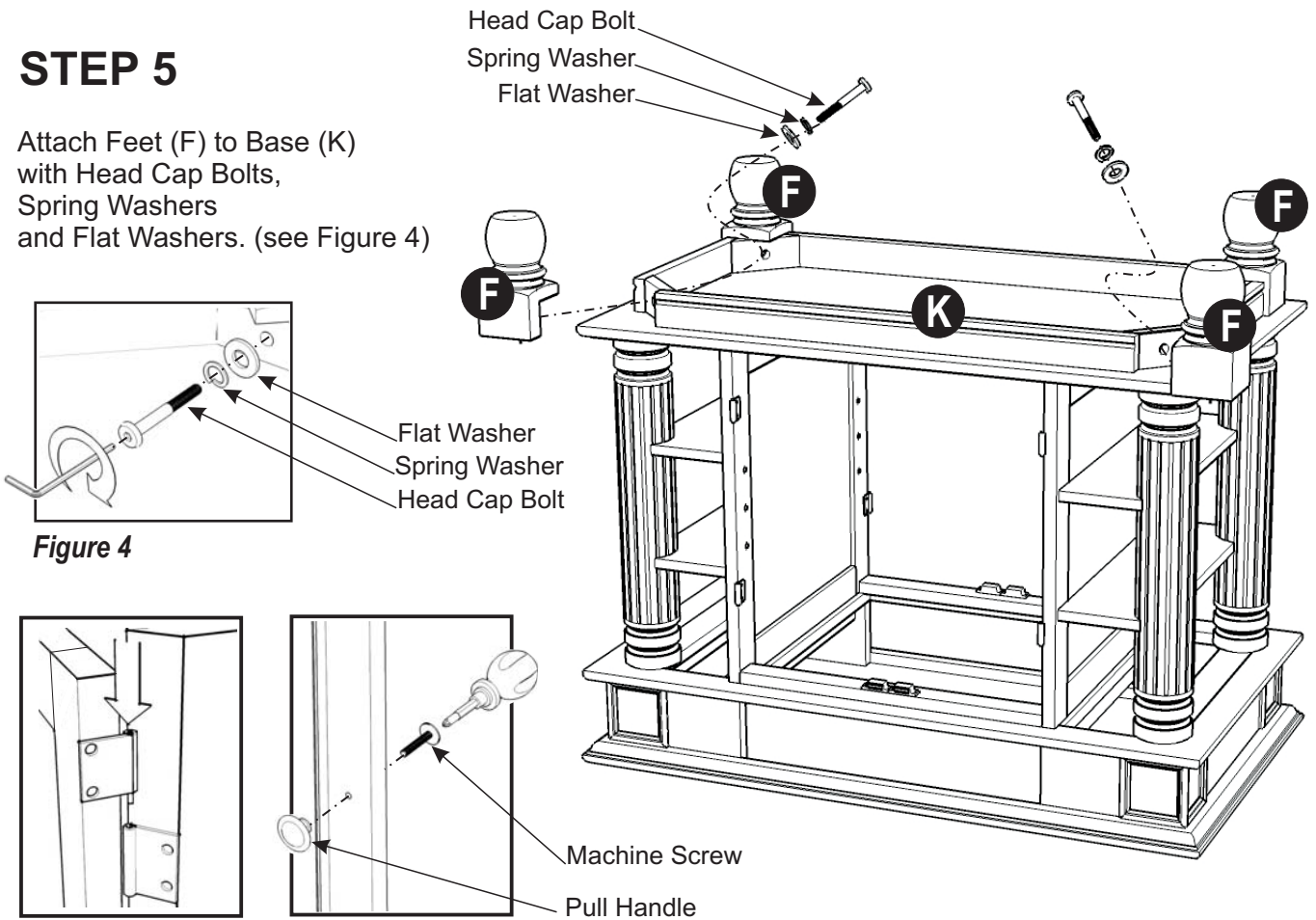

Figure 4

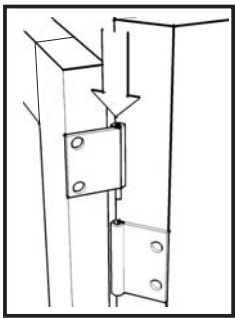

Figure 5

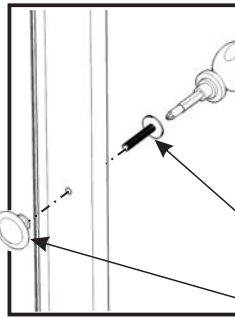

Figure 6

STEP 6

Attach Doors (H) and (I) by sliding the door lift hinges into the side panel lift hinges. (see Figure 5)

Assemble Pull Handles to Doors (H), (I) and Drawer with Machine Screws. (see Figure 6)

Slide Drawer into place.

Insert Adjustable Pins into side panels at the desired level.

Place Shelf (J) into position.

