

NOTICE

- * Please make sure that you have all parts indicated and they are in good condition before you begin assembly of this item. Refer to part list and hardware list below for guidance.
- * This item should be assembled on a soft surface to prevent scratching the finish during assembly.
- * This item may require periodic tightening.
- * If you are having difficulty, our friendly Customer Care team is always here to help. Please email customersupport@safavieh.com

PREPARATION



- * Before beginning assembly of product, make sure all parts are present. Compare parts with part contents list and hardware contents list.
- * If any part is missing or damaged, do not attempt to assemble the product.
- * Estimated Assembly Time: 60 minutes.
- * Tools Required for Assembly (included): Allen Key please adjust these highlighted ones accordingly

CARE AND MAINTENANCE

Store outdoor furniture indoors or cover well when not in use. Remove wooden furniture from standing water. Dust regularly with small brush or vacuum. Spills should be taken care of immediately before they harden or stain with a slightly dampened sponge. Do not use bleach solutions

Part List and Hardware List

PIECE	DESCRIPTION	PICTURE	QUANTITY
A	Left Leg Chair		3X
B	Right Leg Chair		3X
C	Back Bench Frame		1X
D	Seat Bench Frame		1X
E	Back Chair Frame		2X
F	Seat Chair Frame		2X
G	Support Bench Frame		2X
H	Support Chair Frame		4X
I	Top Table		1X
J	Leg Table		4X
CSH1	Seat Bench Cushion		1X
CSH2	Seat Chair Cushion		2X
CSH3	Back Cushion		4X
HW1	Screw: M8 x 0.5 x 70 mm		24X
HW2	Screw: M6 x 0.5 x 35 mm		14X
HW3	Allen Bolt: M6 x 0.5 x 50 mm		8X

PIECE	DESCRIPTION	PICTURE	QUANTITY
HW4	Flat washer: M6 x 1 mm		22X
HW5	Allen Key		2X

Model# PAT7731 -1/1

Product Dimensions

35.43"x19.68"x15.95"H (Table)

48.82"x26.38"x25.39"H (Bench)

26.38"x26.38"x25.39"H (Chair)

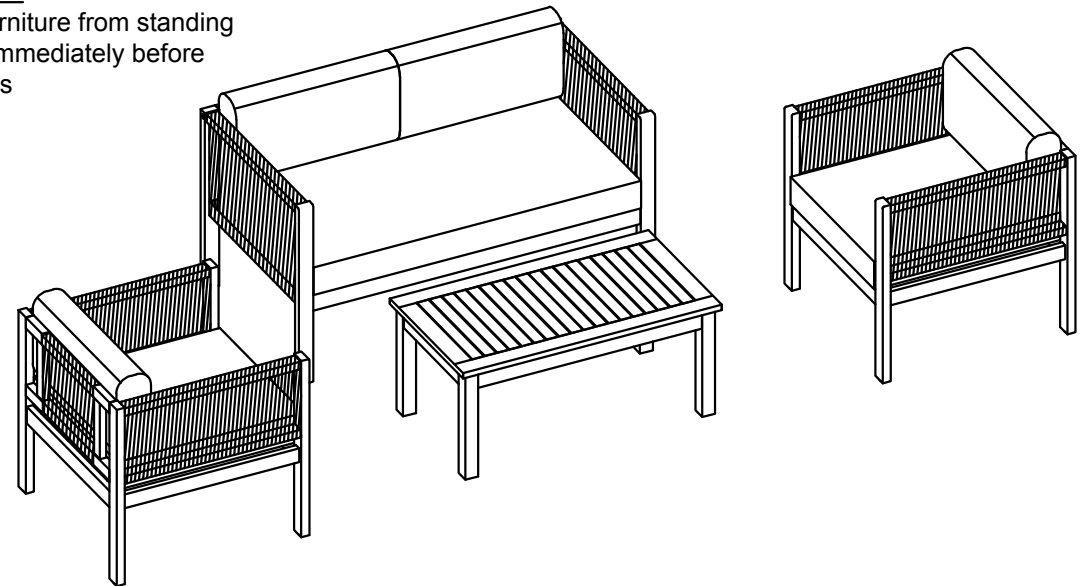

Weight Capacity : 176 lbs (Table)



352 lbs (Single seat)

705 lbs (Two person seat)



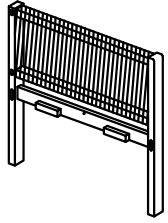
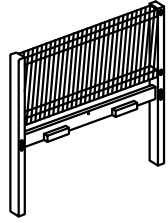
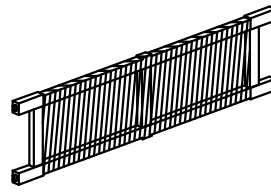
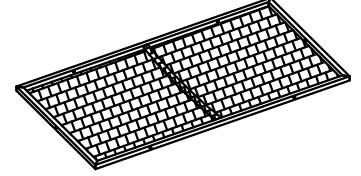
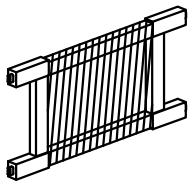
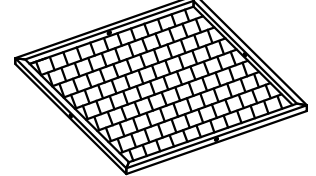
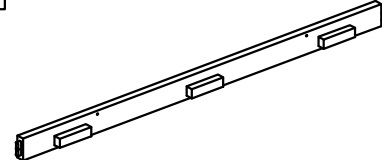
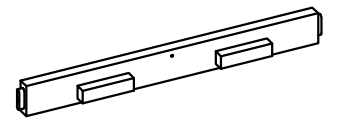
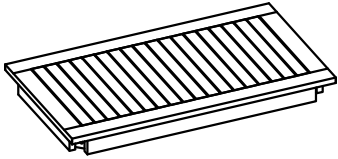

Warning : Do not stand on Table/Bench

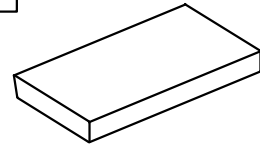
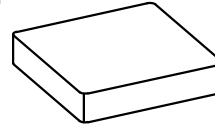
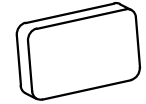
Warning : Do not over torque bolts/screws

PART LIST:

<p>A</p>  <p>Left Leg Chair (3 pcs)</p>	<p>B</p>  <p>Right Leg Chair (3 pcs)</p>	<p>C</p>  <p>Back Bench Frame (1 pc)</p>	<p>D</p>  <p>Seat Bench Frame (1 pc)</p>	
<p>E</p>  <p>Back Chair Frame (2 pcs)</p>	<p>F</p>  <p>Seat Chair Frame (2 pcs)</p>	<p>G</p>  <p>Support Bench Frame (2 pcs)</p>	<p>H</p>  <p>Support Chair Frame (4 pcs)</p>	
<p>I</p>  <p>Top Table (1pc)</p>	<p>J</p>  <p>Leg Table (4 pcs)</p>	<p>CSH1</p>  <p>Seat Bench Cushion (1 pc)</p>	<p>CSH2</p>  <p>Seat Chair Cushion (2 pcs)</p>	<p>CSH3</p>  <p>Back Cushion (4 pcs)</p>

HARDWARE :

<p>HW1</p>  <p>Screw: M8 x 0.5 x 70 mm</p>	<p>HW2</p>  <p>Screw: M6 x 0.5 x 35 mm</p>	<p>HW3</p>  <p>Allen Bolt: M6 x 0.5 x 50 mm</p>	<p>HW4</p>  <p>Flat washer: M6 x 1 mm</p>
<p>HW5</p>  <p>Allen Key</p>			

PREPARATION

- * Before beginning assembly of product, make sure all parts are present. Compare parts with part contents list and hardware contents list.
- * If any part is missing or damaged, do not attempt to assemble the product.
- * Estimated Assembly Time: 60 minutes.
- * Tools Required for Assembly (included): Allen Key
- * If you are having difficulty, our friendly Customer Care team is always here to help. Please email customersupport@safavieh.com

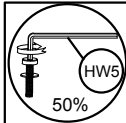

x6 Screw

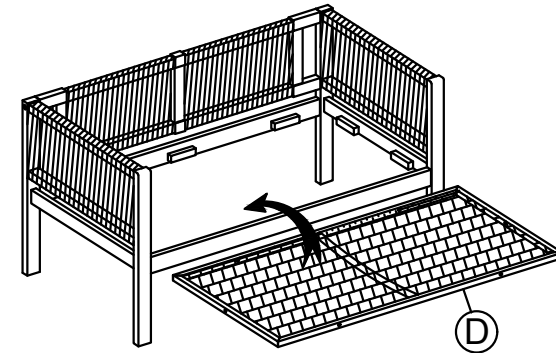
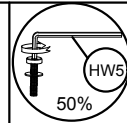
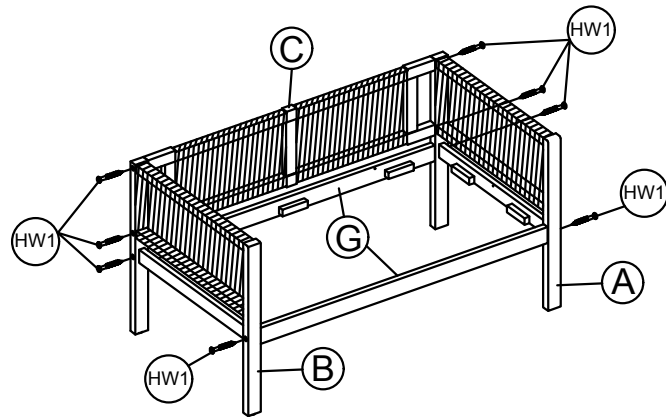

STEP 1: Connect Left Leg Chair (A), Right Leg Chair (B), Back Bench Frame (C) & Support Bench Frame (G) by tighten Screw (HW1) with Allen Key (HW5).

STEP 2: Connect the part from Step 1 & Seat Bench Frame (D) by Hand.

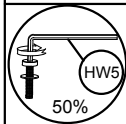

x6 Screw

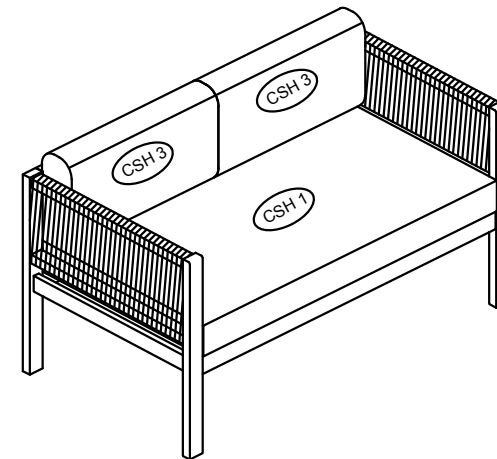
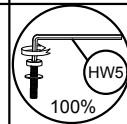
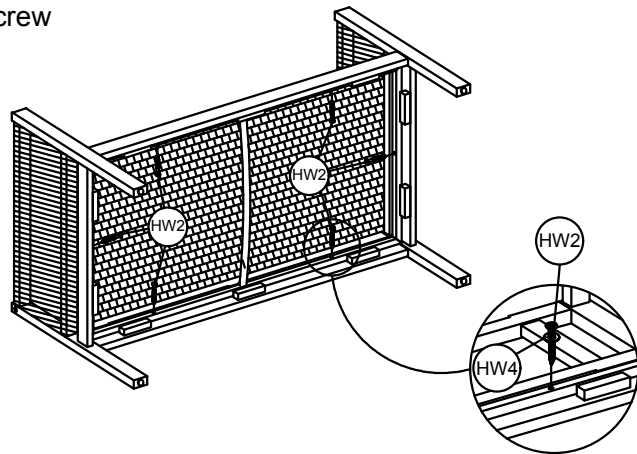

STEP 3: Connect the part from Step 1 & Seat Bench Frame (D) by tighten Screw (HW2), Flat Washer (HW4) with Allen Key (HW5).

STEP 4: Put Seat Bench Cushion (CSH1) & Back Cushion (CSH3) to Finish Bench.

PREPARATION

- * Before beginning assembly of product, make sure all parts are present. Compare parts with part contents list and hardware contents list.
- * If any part is missing or damaged, do not attempt to assemble the product.
- * Estimated Assembly Time: 60 minutes.
- * Tools Required for Assembly (included): Allen Key
- * If you are having difficulty, our friendly Customer Care team is always here to help. Please email customersupport@safavieh.com

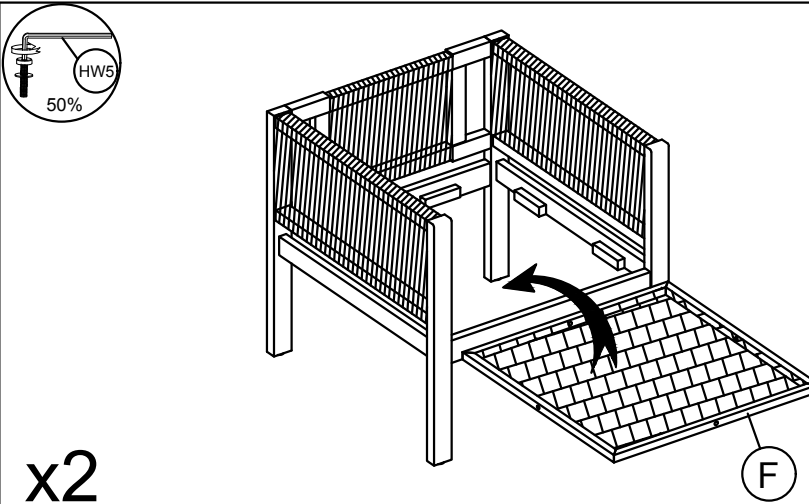
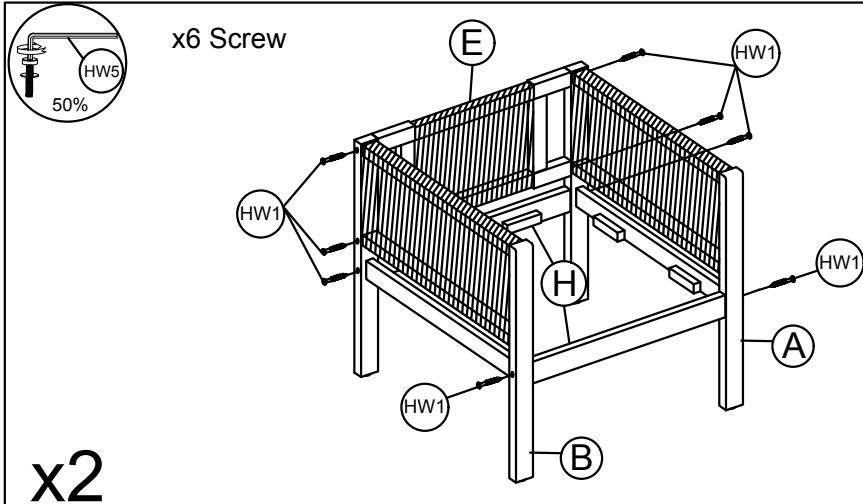

STEP 5: Connect Left Leg Chair (A), Right Leg Chair (B), Back Chair Frame (E) & Support Chair Frame (H) by tighten Screw (HW1) with Allen Key (HW5).

STEP 6: Connect the part from Step 5 & Seat Chair Frame (F) by Hand.

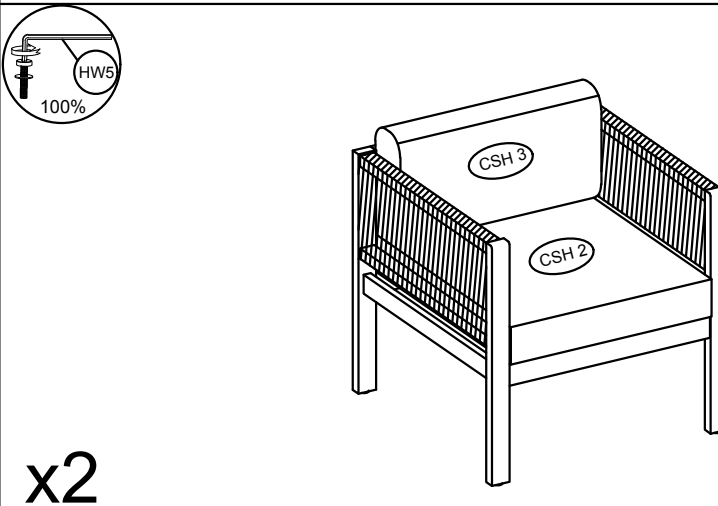
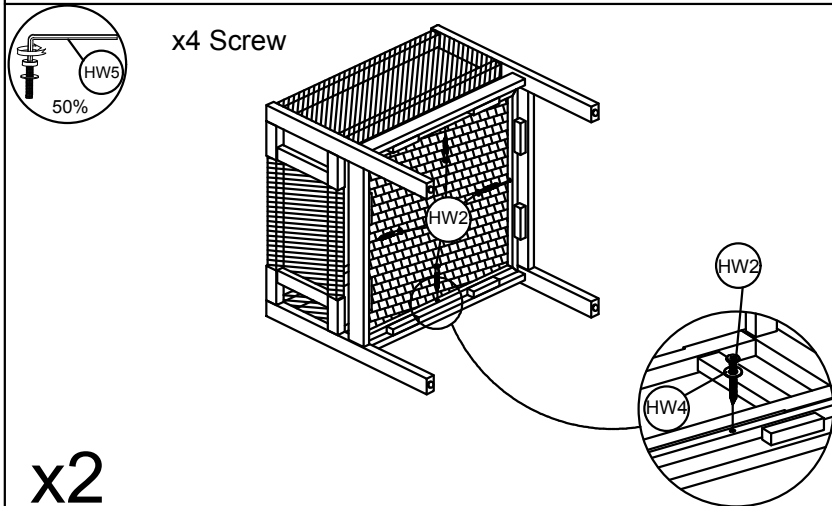

STEP 7: Connect the part from Step 5 & Seat Chair Frame (F) by tighten Screw (HW2), Flat washer (HW4) with Allen Key (HW5).

STEP 8: Put Seat Chair Cushion (CSH2) & Back Cushion (CSH3) to Finish Chair.

PREPARATION

- * Before beginning assembly of product, make sure all parts are present. Compare parts with part contents list and hardware contents list.
- * If any part is missing or damaged, do not attempt to assemble the product.
- * Estimated Assembly Time: 60 minutes.
- * Tools Required for Assembly (included): Allen Key
- * If you are having difficulty, our friendly Customer Care team is always here to help. Please email customersupport@safavieh.com

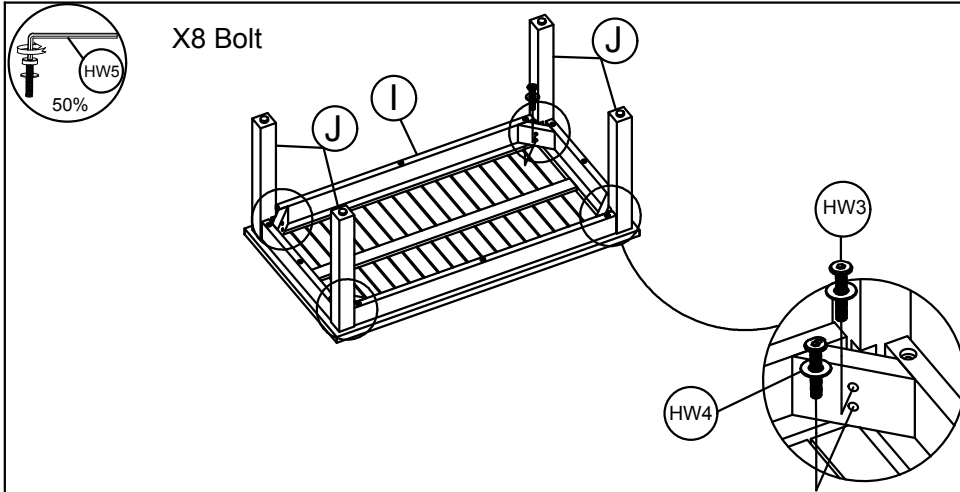

STEP 9: Connect Top Table (I) & Leg Table (J) by tighten Bolt (HW3), Flat washer (HW4) with Allen Key (HW5).

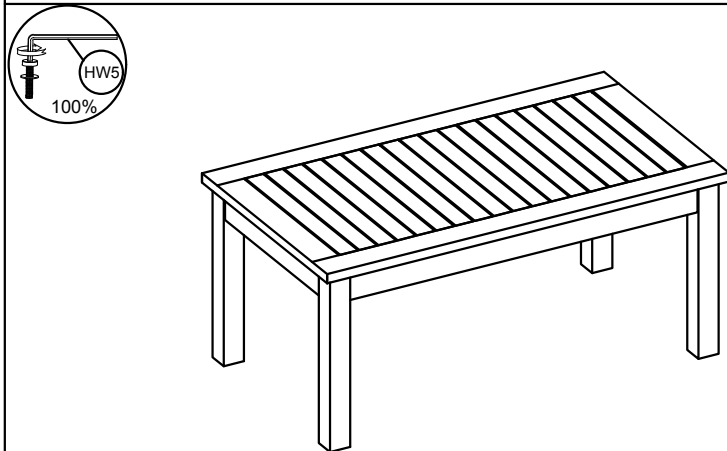

STEP 10: Finish Table

