

ASSEMBLY INSTRUCTIONS

Before assembling your headboard, please read through these instructions carefully and familiarize yourself with the different parts.



PARTS LIST

- ① LEFT POST 1 PC
- ② RIGHT POST 1 PC
- ③ HB TOP RAIL 1 PC
- ④ MID RAIL 1 PC
- ⑤ HB BOTTOM RAIL 1 PC
- ⑥ FOOTBOARD PANEL 1 PC
- ⑦ LEFT LEG 1 PC
- ⑧ RIGHT LEG 1 PC
- ⑨ FB TOP RAIL 1 PC
- ⑩ FB BOTTOM RAIL 1 PC

Instructions apply for bed sizes
TWIN

HARDWARE

- ① JCB M6 X 110mm - 8 pcs
Spare - 1 pc
- ② Barrel Nut - 8 pcs
Spare - 1 pc
- ③ JCB M8 X 15mm (5/8") - 8 pcs
Assembly headboard and footboard to side rails
- ④ Wood Dowel - 16 pcs
Spare - 1 pc
- ⑤ Allen wrench - 1pc
Spare - 1pc
- ⑥ Allen wrench M6 - 1pc

NOTE: WE INCLUDE SPARE HARDWARE IN CASE DAMAGE OCCURS DURING ASSEMBLY.

Step 1

Insert all wooden dowels (D) into the locator holes on (3)(4)(5)(9) and(10) as shown below.

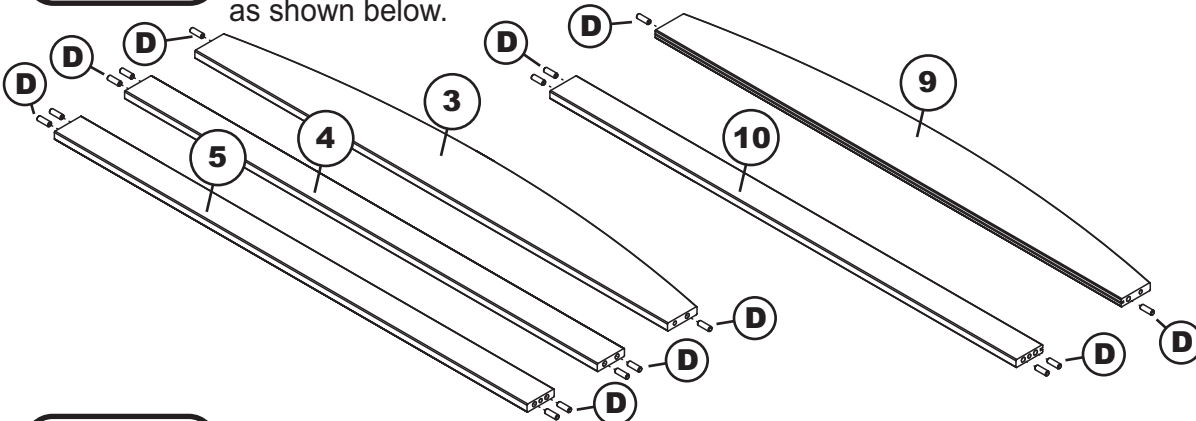

Adult assembly

④



Wood Dowel

Step 2

Lay the left and right post (1)(2) bracket face down on smooth surface. Connect HB top rail (3), mid rail (4) and HB bottom rail (5) as shown below, using JCB M6 X 110mm (A) and barrel nut (B). Tighten with the Allen wrench (E).

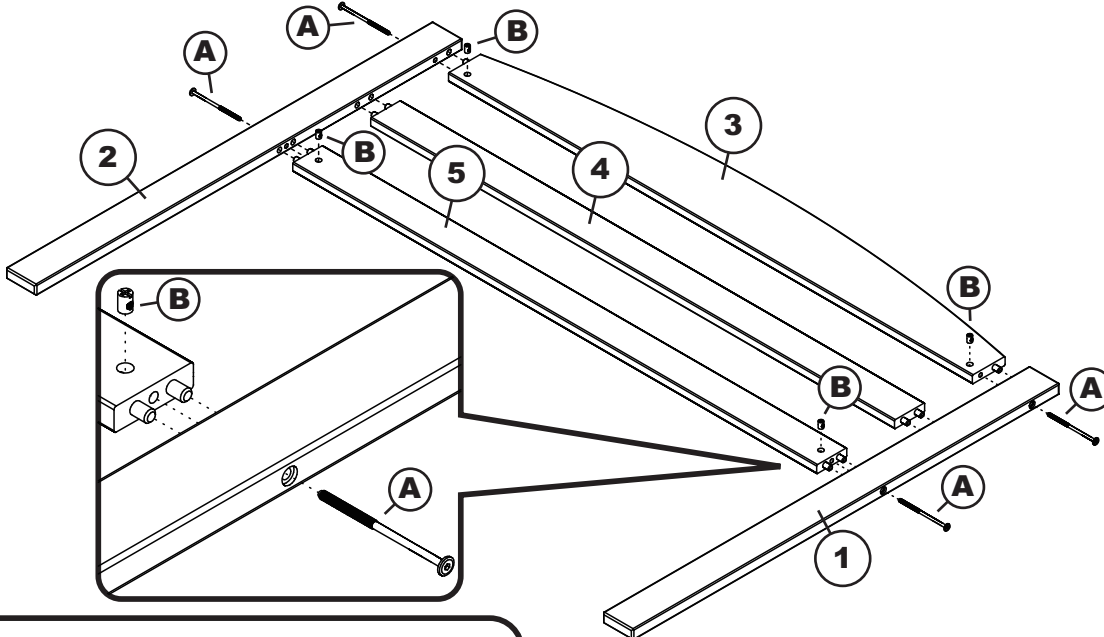

Adult assembly

①

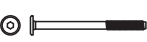

JCB M6 X 110mm

②



Barrel Nut

PO:

Step 3

Lay the left leg (7) bracket face up on smooth surface to FB top rail (9) and FB bottom rail (10) as shown below, using JCB M6 X 110mm (A) and barrel nut (B). Tighten with the Allen wrench (E).

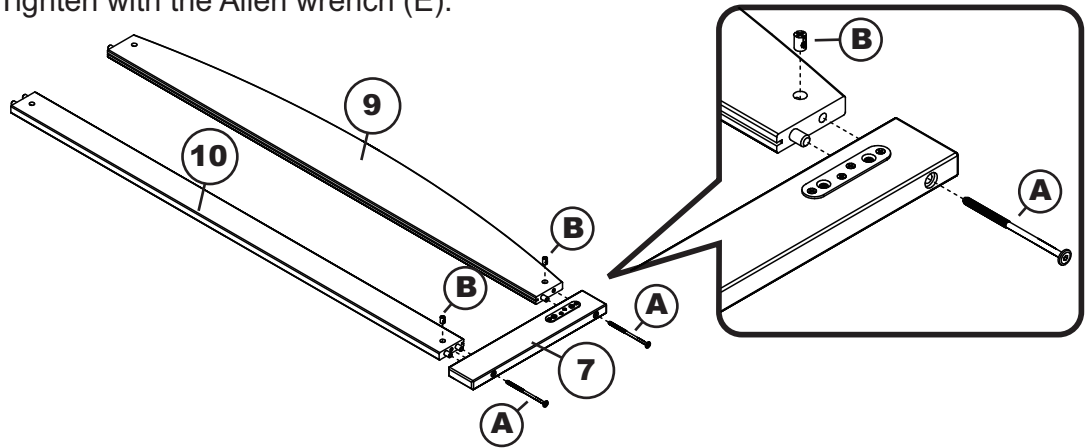

Step 4

Guide the footboard panel (6) in carefully so that it won't jump out of its grooves. Be sure it fits fully into the groove at the end (in the leg) before fitting the other leg.

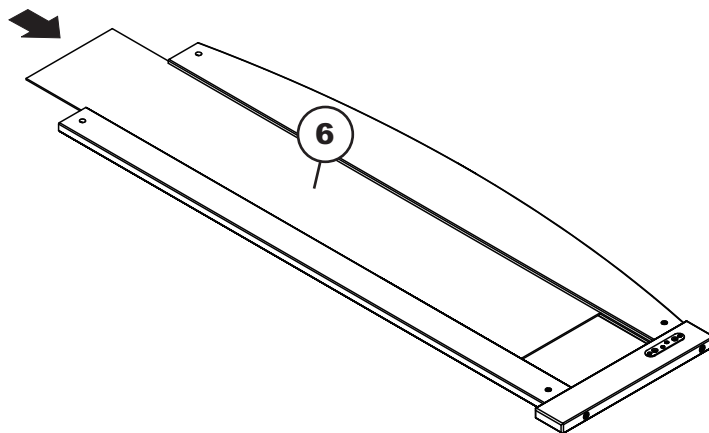

Adult assembly

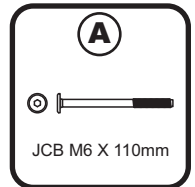

JCB M6 X 110mm

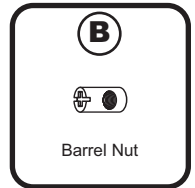

Barrel Nut

Step 5

Attach the right leg (8) to footboard assembly as shown below, using JCB M6 X 110mm (A) and barrel nut (B). Tighten with Allen wrench (E)

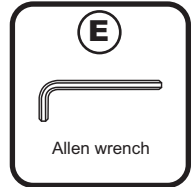
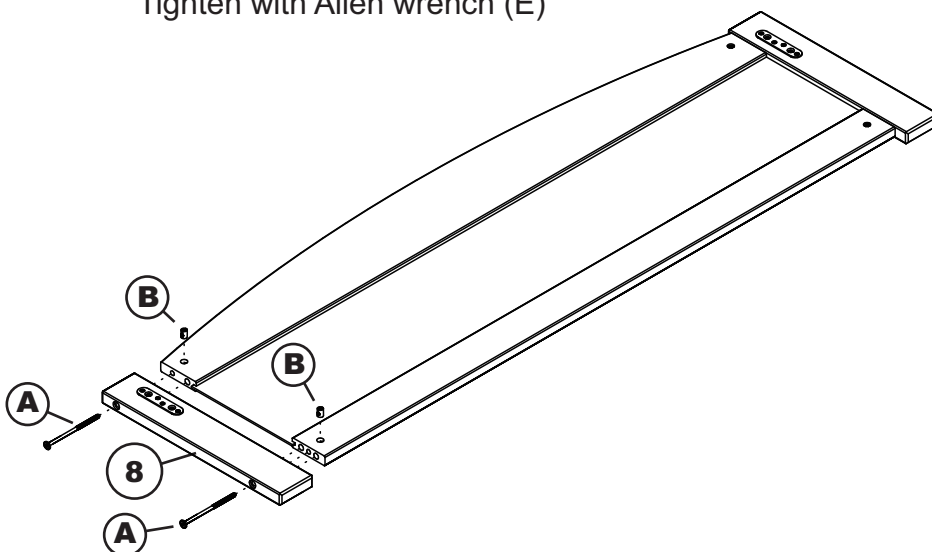

Allen wrench

TWIN



- 01 HARDWARE
 - 02 HEADBOARD
 - 03 FOOTBOARD
- BOX 1

- 01 HARDWARE
 - 04 SIDE RAILS
 - 05 SLAT KIT
- BOX 2

Step 1

Attach the side rails (04) to the headboard (02) and footboard (03) using JCB M8 X 15mm (C). Tighten with Allen wrench M6 (F).

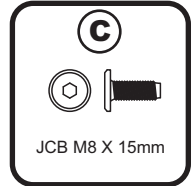
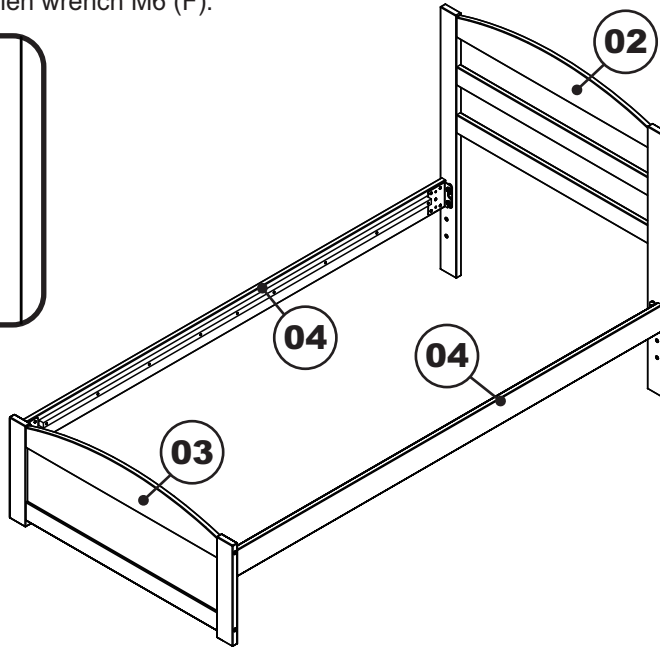
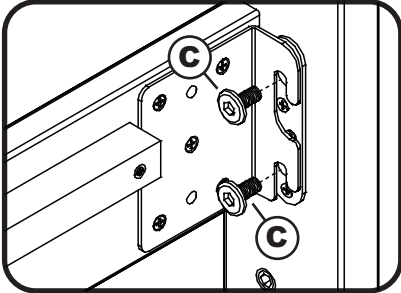

Step 2

Attach slat kit (05) onto the bed using wood screws. Tighten with Phillips head screw driver. (customer supplied) For assembly of slat kit, follow the assembly instructions included with bed frame.

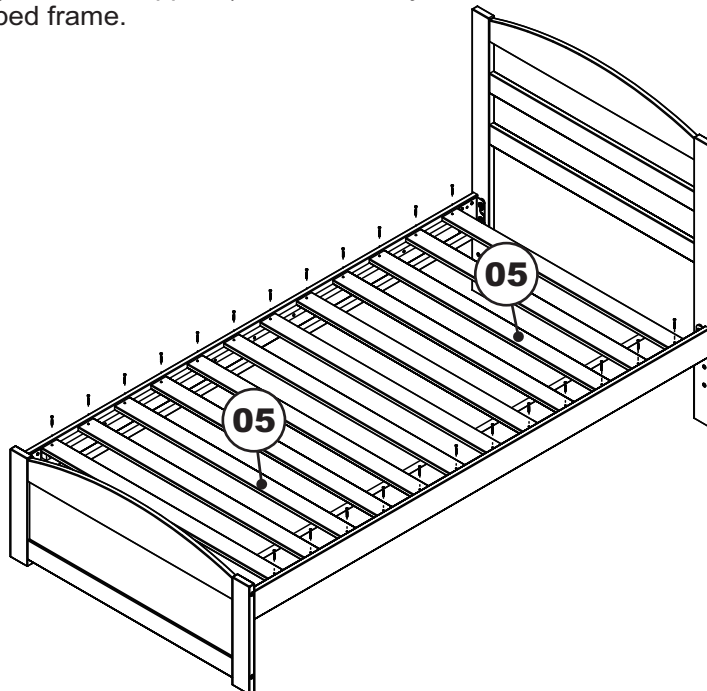

Congratulations!

Your bed is now ready for use.

We recommend that you periodically recheck that all screws are tight to ensure lasting safety.