

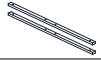

# ASSEMBLY INSTRUCTION

ITEM :



## BOX OF MIRROR MIRROR

ITEM	DRAWING	DESCRIPTION	QTY
A		MIRROR	1
B		MIRROR SUPPORT RAIL	2

## BOX OF DRESSER DRESSER

ITEM	DRAWING	DESCRIPTION	QTY
A		DRESSER	1

## BOX OF MIRROR HARDWARE LIST

ITEM	DRAWING	DESCRIPTION	QTY
1		JCBC SCREW M6x40mm	8
2		L-KEY M4x65mm	1

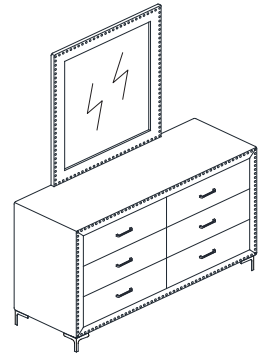

COMPLETED MIRROR ASSEMBLY

### STEP 1

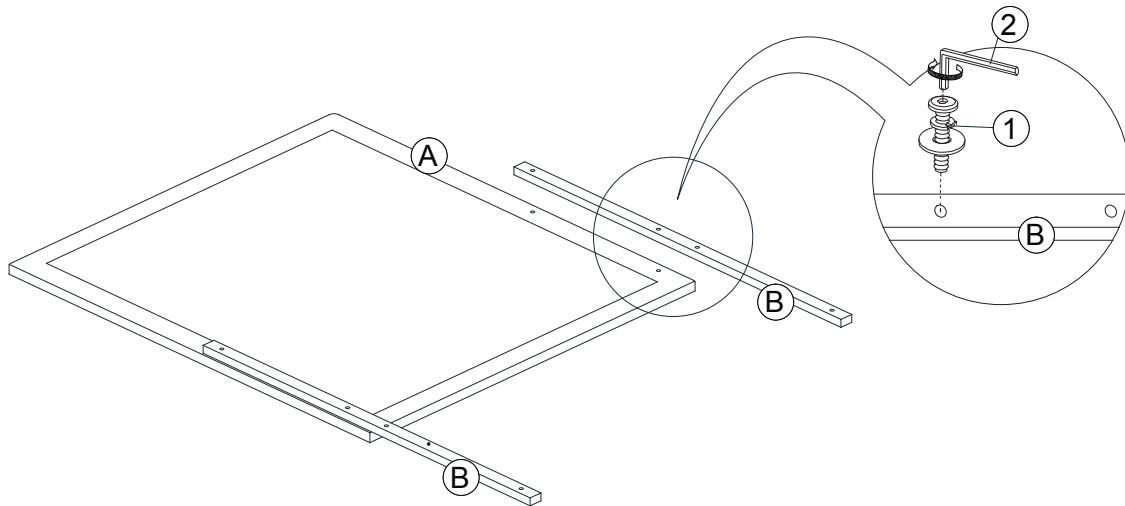

### STEP 2

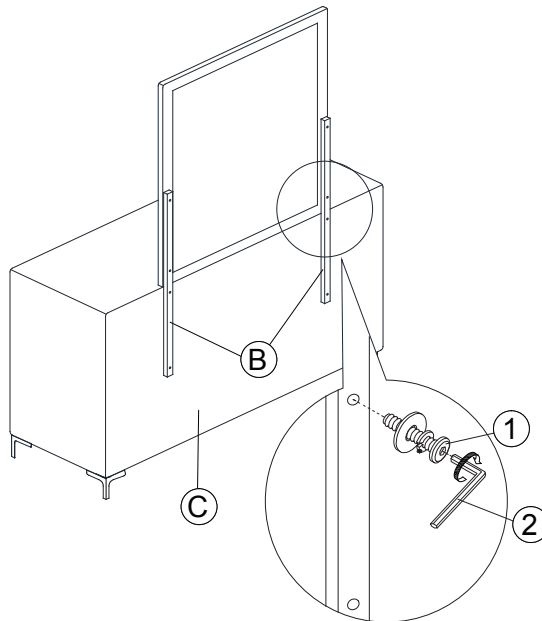

THE HARDWARE ID LOCATED IN THE PACKING ITEMS

NOTE : MUST TIGHT SCREWS PERIODICALL WITH USE SCREWS MAY BECOME LOOSE.  
CHECK TIGHNESS OF ALL SCREWS EVERY 6-8 WEEKS.

MADE IN MALAYSIA