

# ASSEMBLY INSTRUCTION

ITEM NO. THKFBV254GY1BW

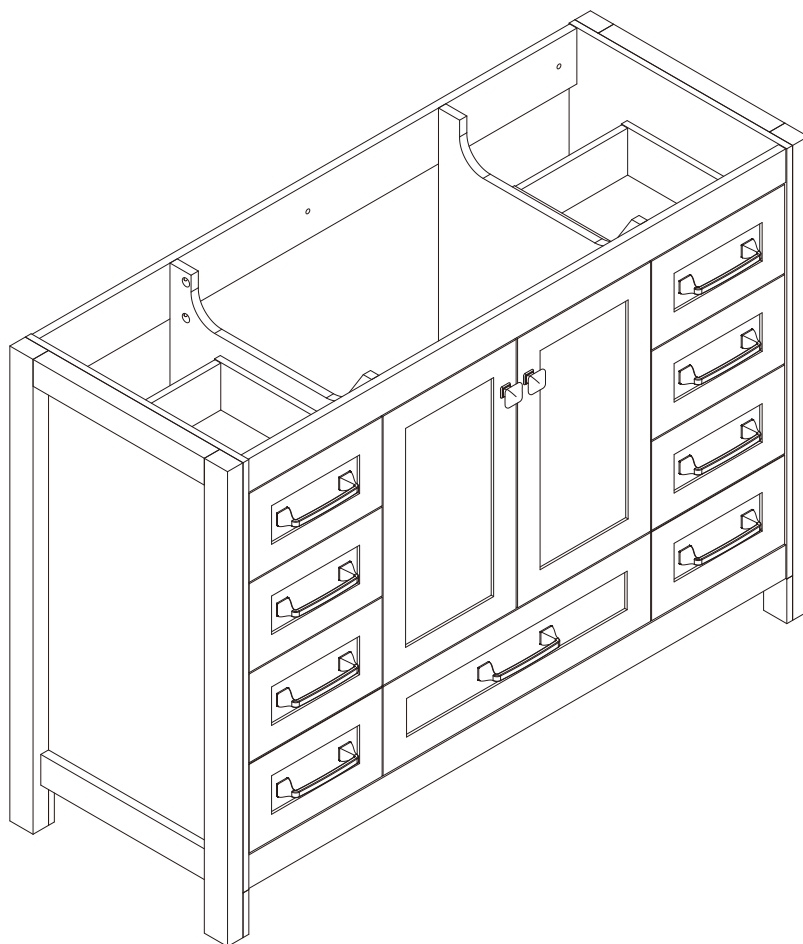

# IMPORTANT NOTICE

## **Workspace Safety**

Keep the workspace clear of clutter and ensure it is well-lit. A clean, flat surface is essential.

## **Read Instructions**

Read the entire assembly guide before starting. Skipping steps can compromise safety.

## **Use Proper Tools**

Use the tools provided or recommended. Avoid overtightening screws.

## **Secure Furniture**

Anchor tall or heavy furniture to the wall to prevent tipping. This is crucial in homes with children or pets.

## **Handle Small Parts**

Keep small parts away from children and pets to avoid choking hazards.

## **Get Help**

Don't hesitate to ask for help with heavy or complex pieces.

## **Inspect Regularly**

Periodically check for loose screws or wobbly parts and tighten as needed.

Follow these tips for a safe assembly process.

# CARE AND CLEANING

Many cleaners contain abrasive and chemical substance which is not suitable for cleaning stainless steel, enamel, plating or plastic products. You may use mild cleansers or soaps to clean the surfaces. Wipe any splashes of cleaner solutions from the surface with a clean soft cloth.

Maintain ventilation in the bathroom and separate the dry area from the damp one if conditions permit. Try to open the door and windows of the bathroom to maintain adequate ventilation.

This cabinet is built to withstand normal bathroom humidity. For best results, keep this vanity dry and take necessary steps to minimize bathroom humidity by opening windows and doors and using the exhaust fan (if available).

To maintain the cabinet door, clean and wipe the door regularly with a soft cloth. Wipe condensation with a dry, soft cloth. Keep away from high temperatures.

Please do not sit, lean or step on the basin cabinet.

# ASSEMBLY DIAGRAM

1. Refer to the exploded view below for the approximate location of each component.
2. Each part is labeled for easy identification.
3. Follow the assembly instructions carefully to ensure proper installation.

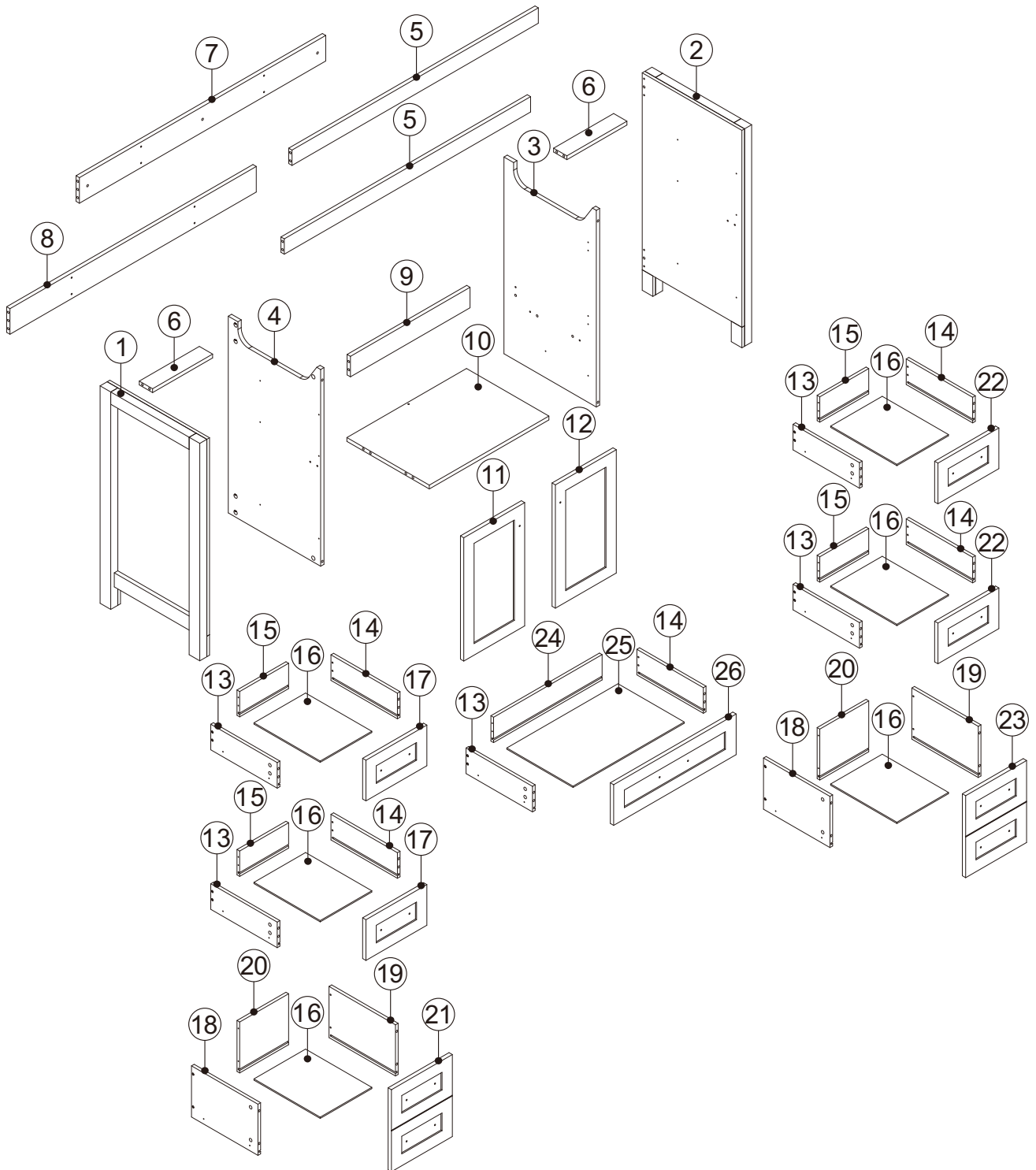







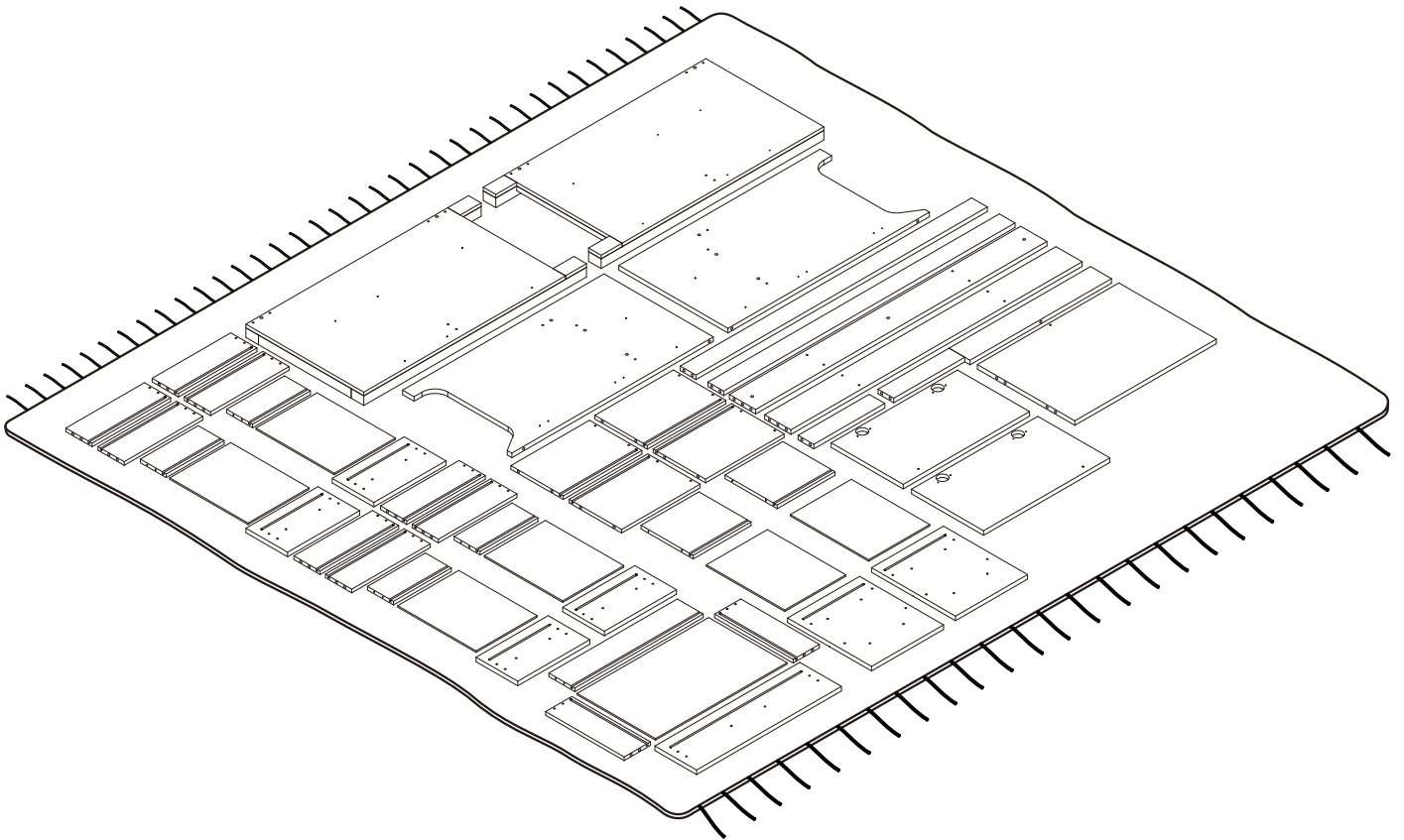







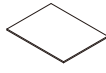

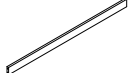

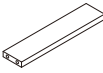



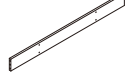

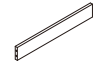

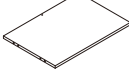
## PRE-ASSEMBLY PREPARATION

Before assembly, place all furniture parts on a soft surface, such as a blanket or the original packaging cardboard, to prevent damage to the floor or components from accidental drops and to avoid scratching the surfaces.















# PARTS LIST

No.	Description	QTY	No.	Description	QTY
1		1	14		5
2		1	15		4
3		1	16		6
4		1	17		2
5		2	18		2
6		2	19		2
7		1	20		2
8		1	21		1
9		1	22		2
10		1	23		1
11		1	24		1
12		1	25		1
13		5	26		1

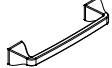
**CAUTION:** Please confirm the parts list before installtion.

# HARDWEAR LIST

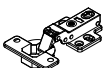
No.	Description	QTY	No.	Description	QTY
A		71	I	 Screws M4x30	28
B	 Ø15mm	43	J	 Screws M4x20	2
C	 Ø12mm	28	K	 Screws M4x14	18
D		10	L		2
E	 Screws M4x12	108	M		9
F	 M S	14	N	 Screws For Fix On The Wall M5.5x60	3
G		4	O	 Wood grain Cover	28
H		4			

**CAUTION:** Please confirm the parts list before installtion.

# YOU MAY NEED (NOT SUPPLIED)

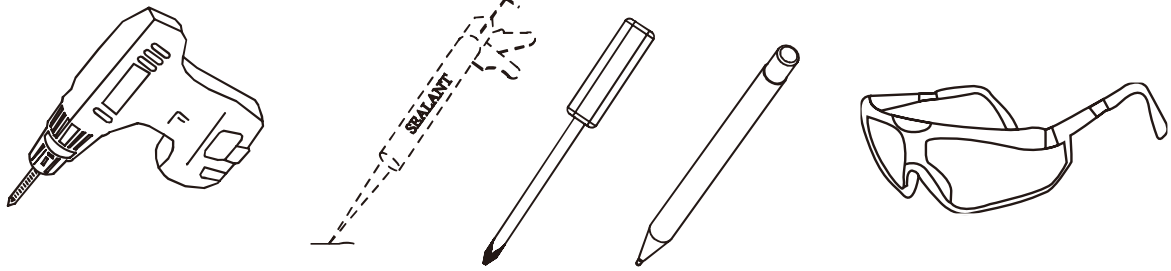

## 01

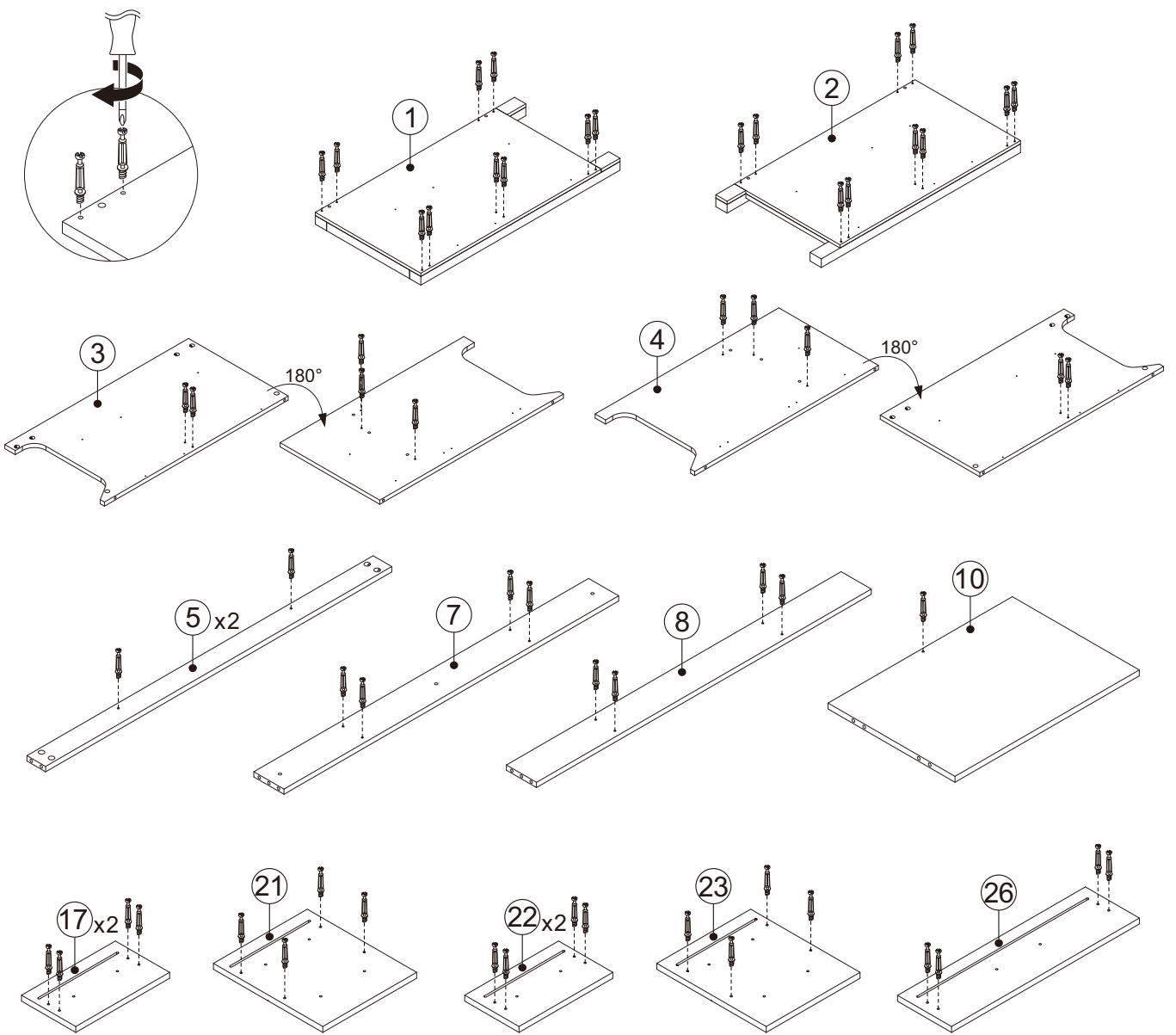
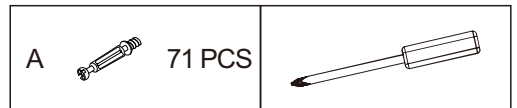

● Insert the Cam Screw into the boards above.

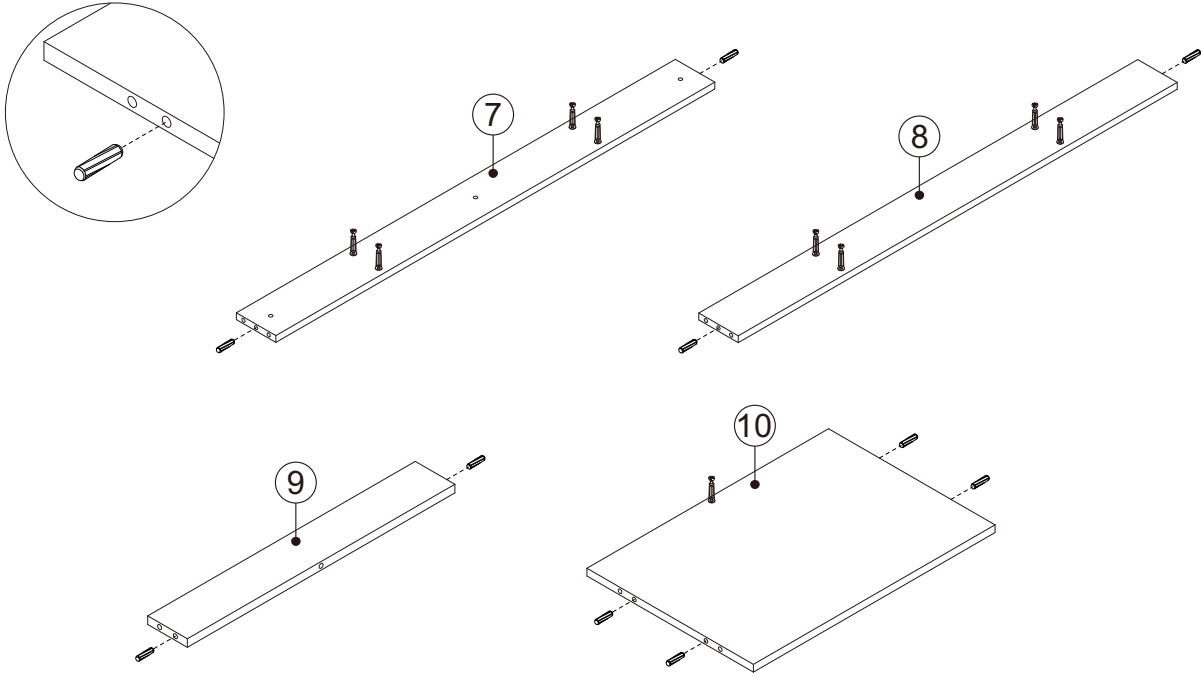

# 02

D		10 PCS
---	---	--------



● Insert the wooden dowel pins into the boards.

# 03

E		42 PCS
F	M 	14 PCS
G		4 PCS

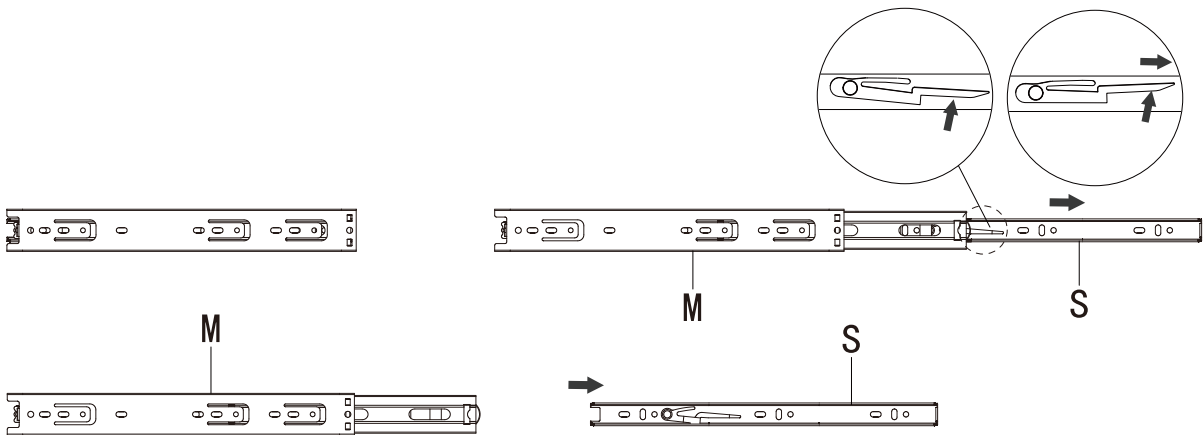
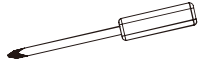

● Keep pressing here, then pull out to divide the slide.

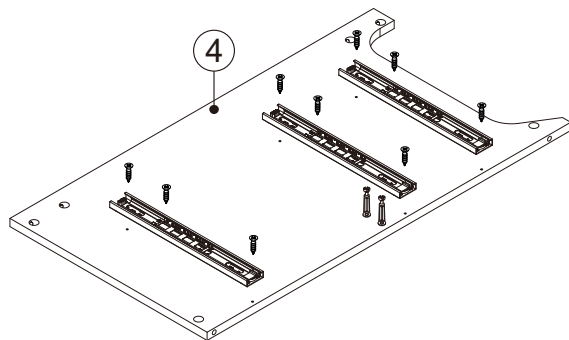
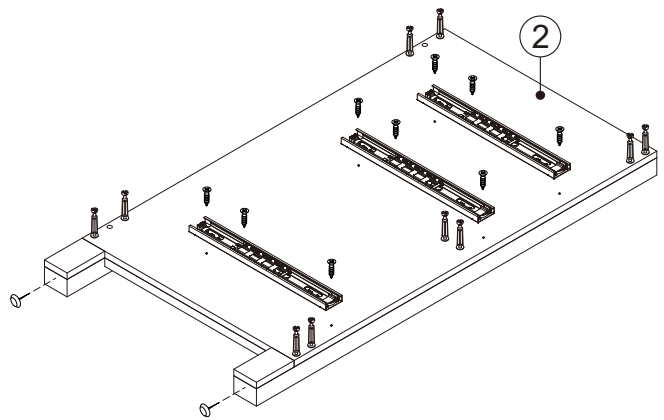
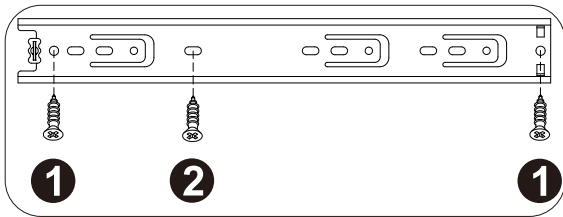
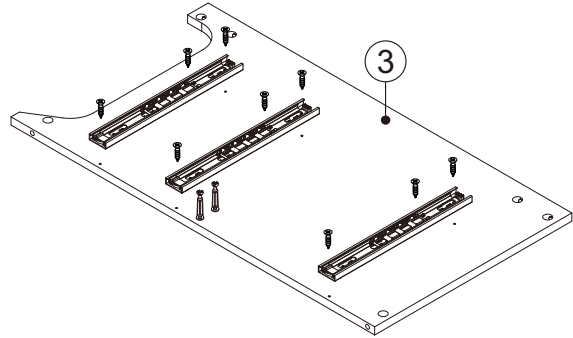
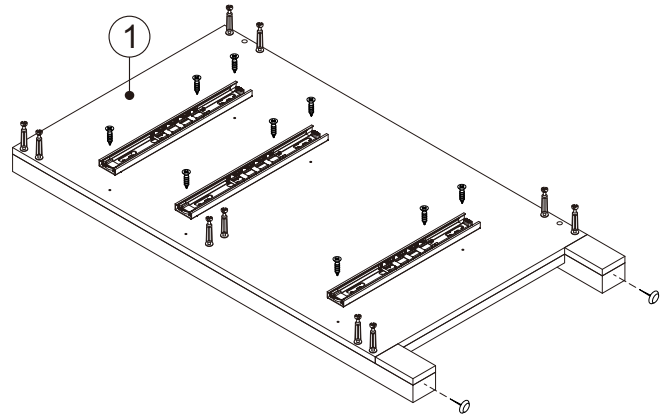
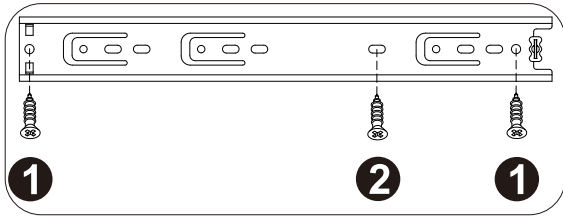

- Refer to the illustration, to fix the slide rails to the boards #1, #2, #3, #4 with screws.

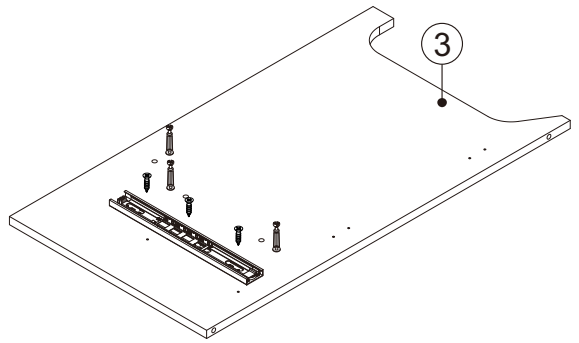
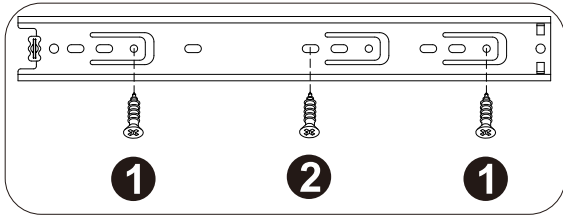
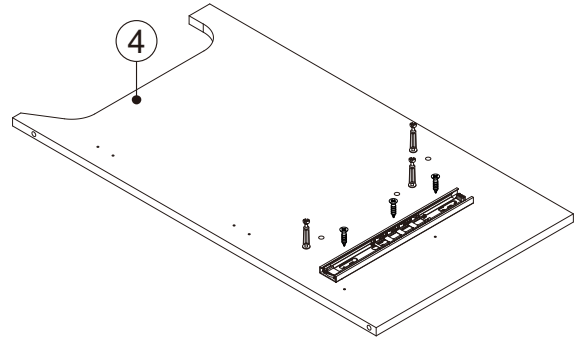
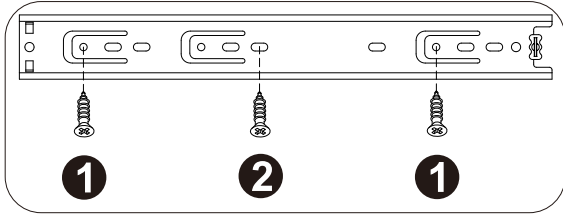

● Refer to the illustration, to fix the slide rails to the boards #3, #4 with screws.

# 04

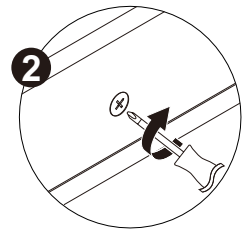
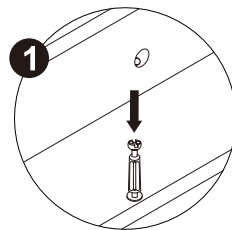
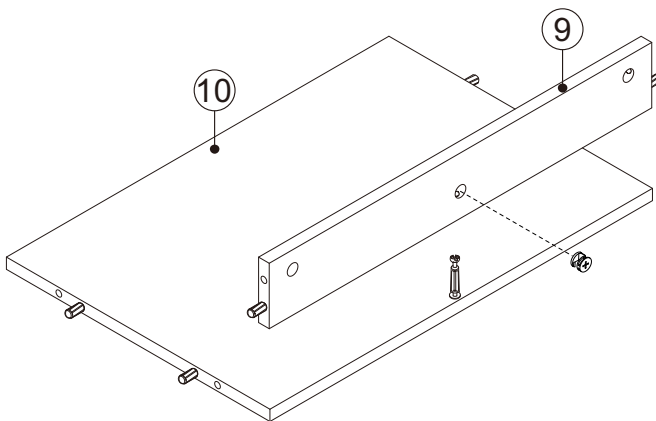
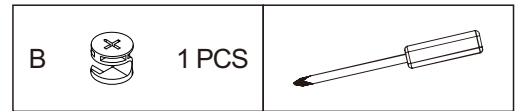

● Refer to the illustration, the board #9 insert the board #10. Then tighten the cam lock.

# 05

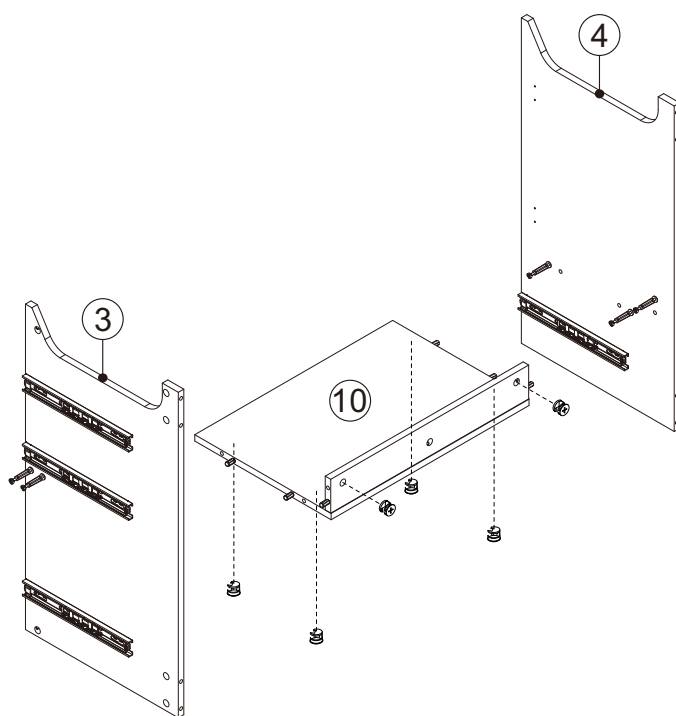

B  6 PCS

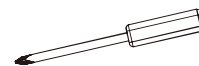

- Insert the board #3, #4 into the assembled board. Then tighten the cam lock.

# 06

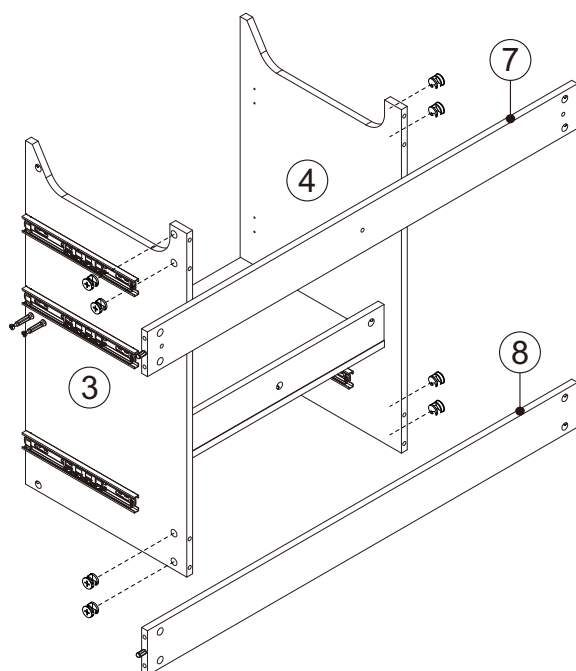

B  8 PCS

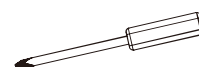

- Insert the boards #7, #8 into the assembled board. Then tighten the cam lock.

# 07

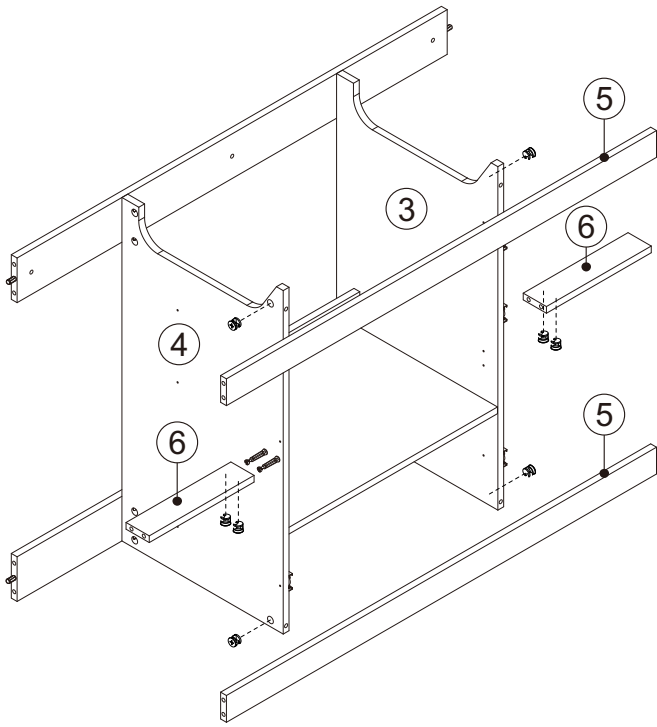

B



8 PCS

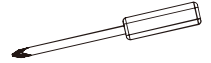

- Insert the board #5, #6 into the assembled board. Then tighten the cam lock.

# 08

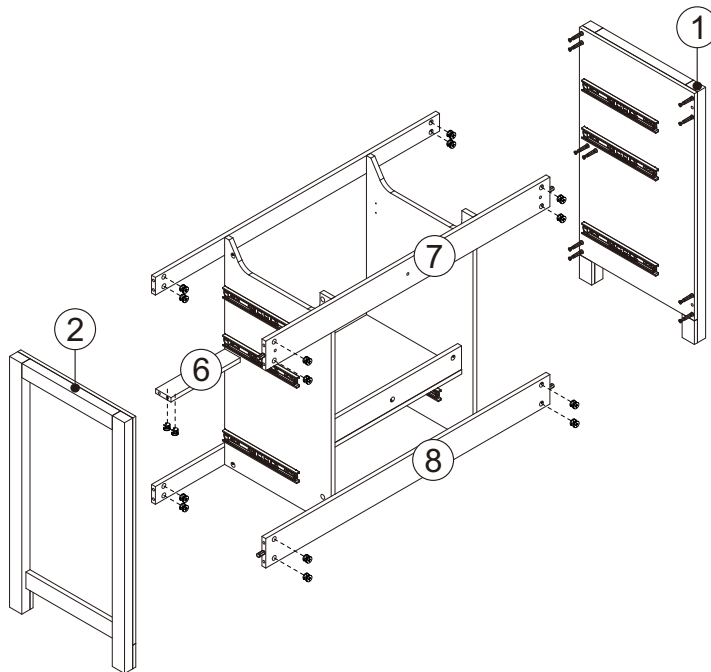

B



20 PCS

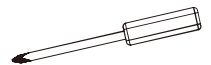

- Insert the boards #1, #2 into the assembled board. Then tighten the cam lock.

# 09

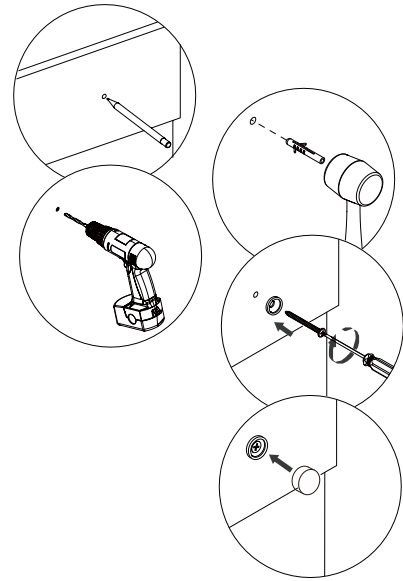
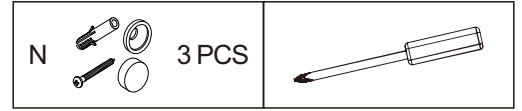
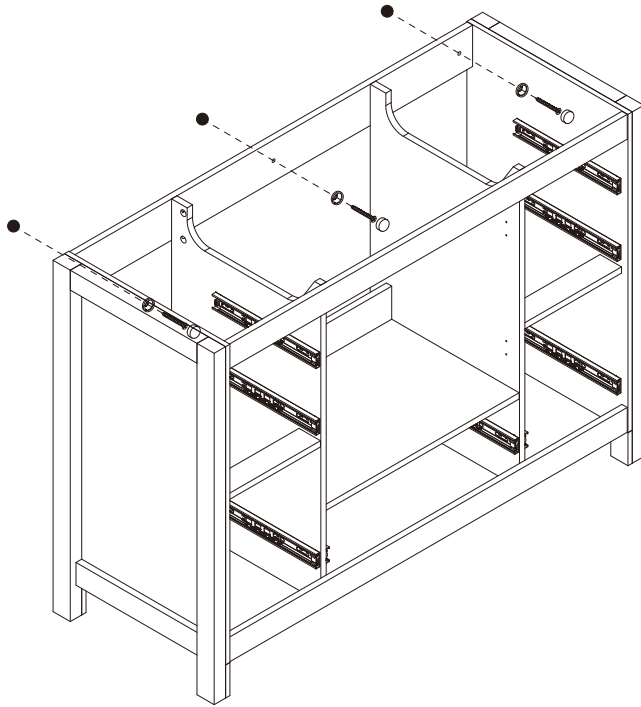

- Refer to the illustration, draw the spacing between the walls on the cabinet, punch holes in the wall, and fix the cabinet to the wall with screws. Then tighten the nut cover.

# 10

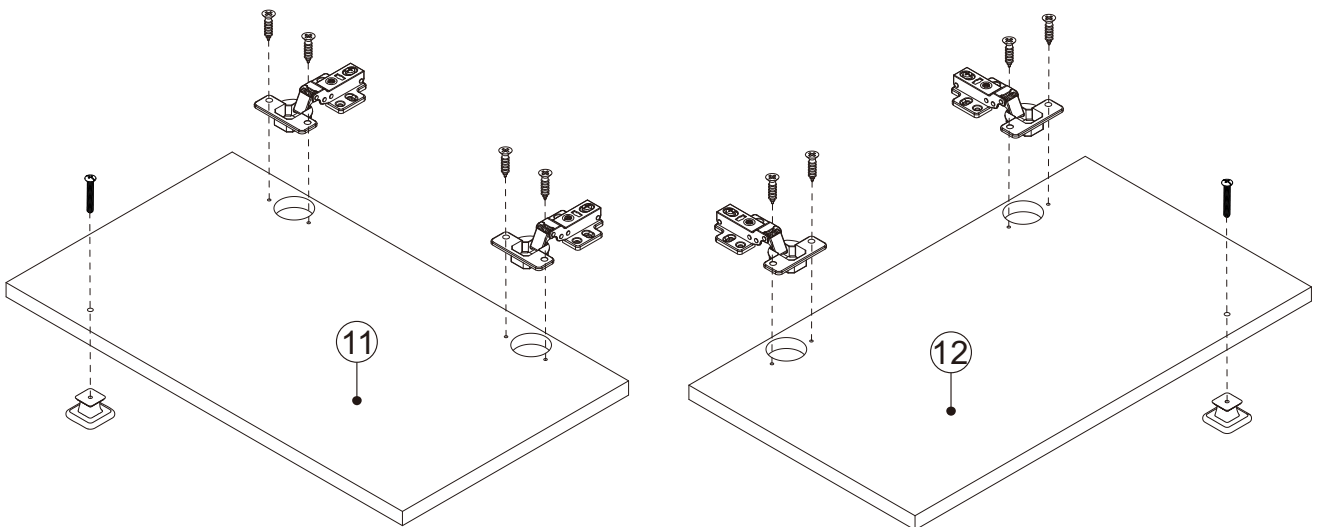
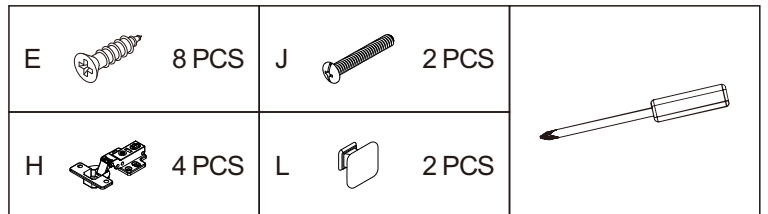

- The hinge bracket use screws installation to the door board #11, #12. Use screws to installation the handle.

# 11

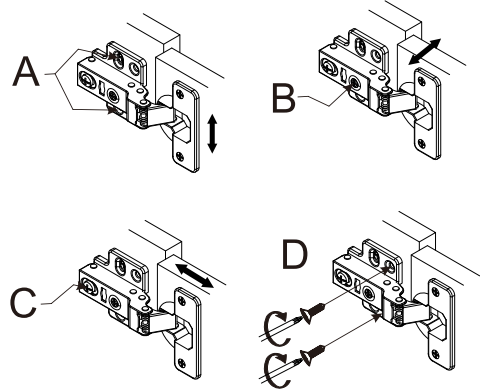
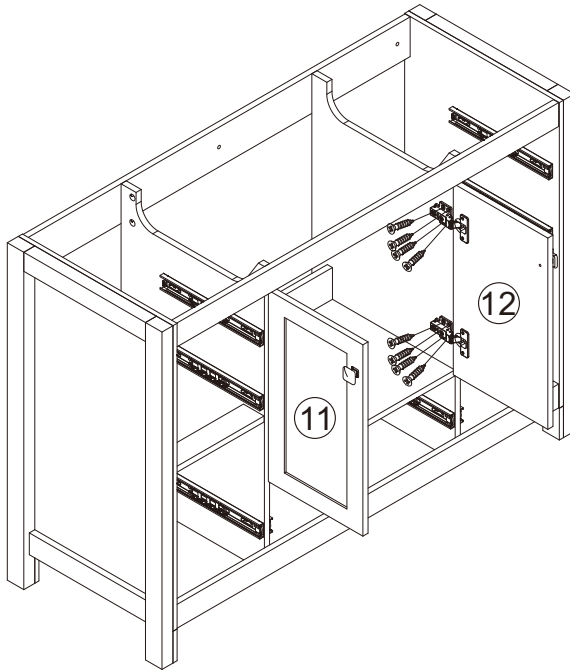

- A. Height adjustment    B. Side to side adjustment  
C. Depth adjustment    D. After adjustment A/B/C, tighten screws.

- Refer to the illustration, to ensure proper cabinet alignment, refer to the above illustrations for instructions about adjusting the cabinet height, depth and lateral movement.

# 12

x4

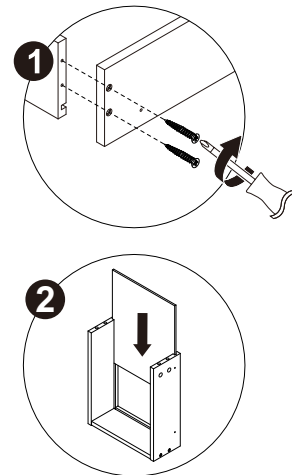
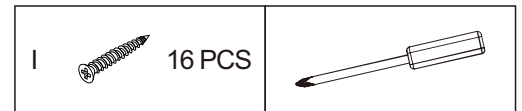
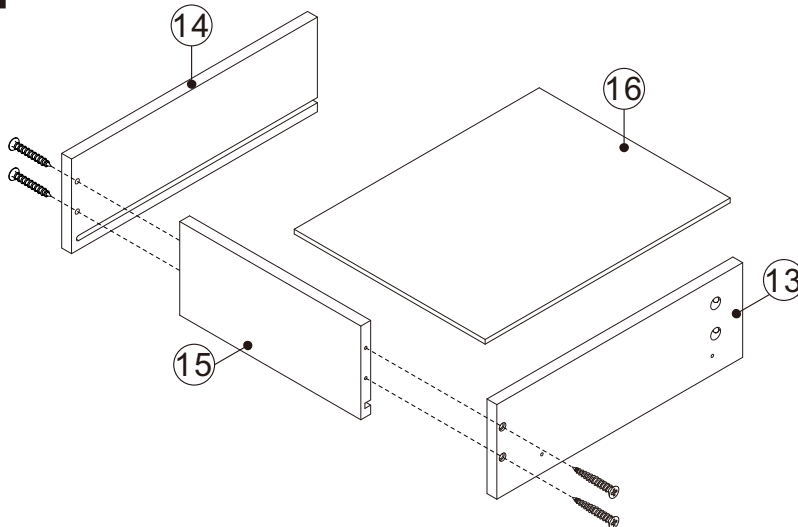

- Refer to the illustration,  
1. Connet the #13, #14, #15 together with screws.  
2. Insert the #16 into the assembled board.

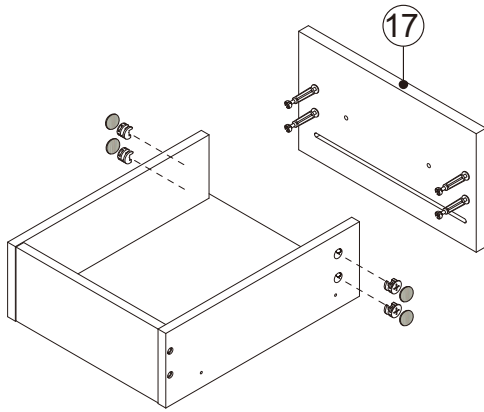

# 13

x2

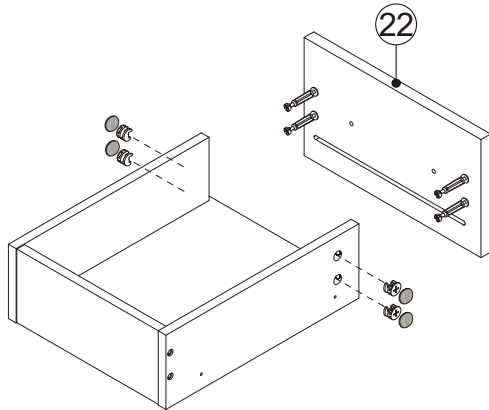

x2



C		16 PCS
O		16 PCS

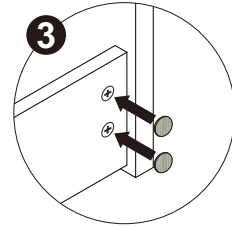
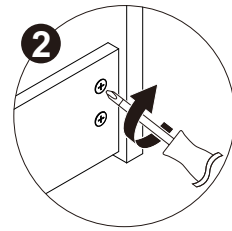
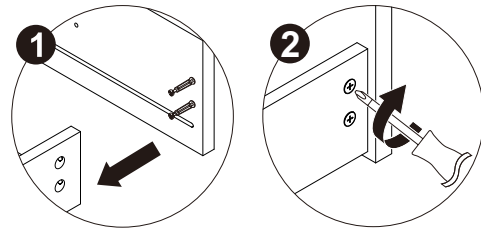
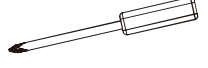



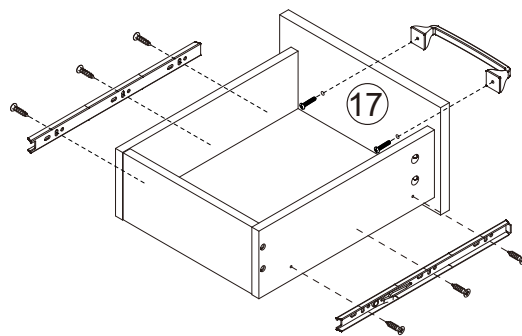
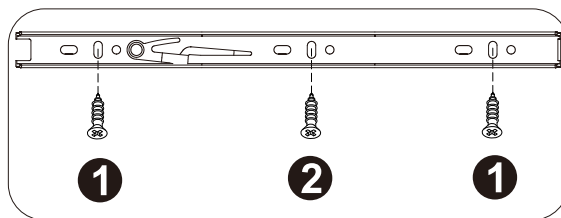

- Refer to the illustration, the drawer panel #17,#22 is insert into the assembled board. Then tighten the cam lock with the cover.

# 14

x2



E		24 PCS
F		8 PCS
K		8 PCS
M		4 PCS



- Refer to the illustration, apply screws to fix the slides on the boards. Then use screws to installation the handle on the drawer panel.

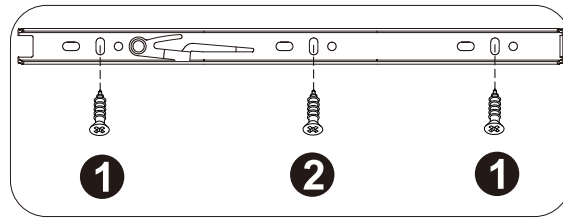

**x2**

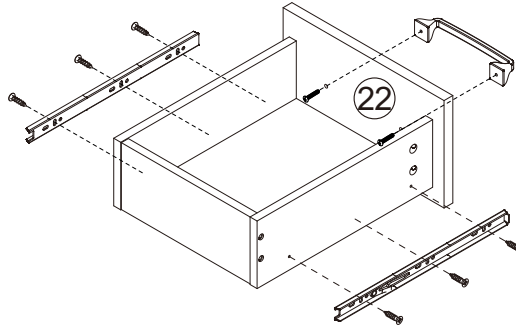

- Refer to the illustration, apply screws to fix the slides on the boards. Then use screws to installation the handle on the drawer panel.

**15**

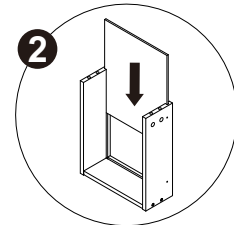
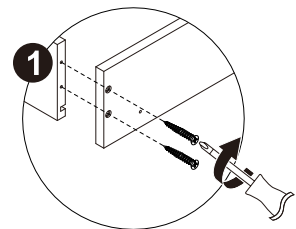
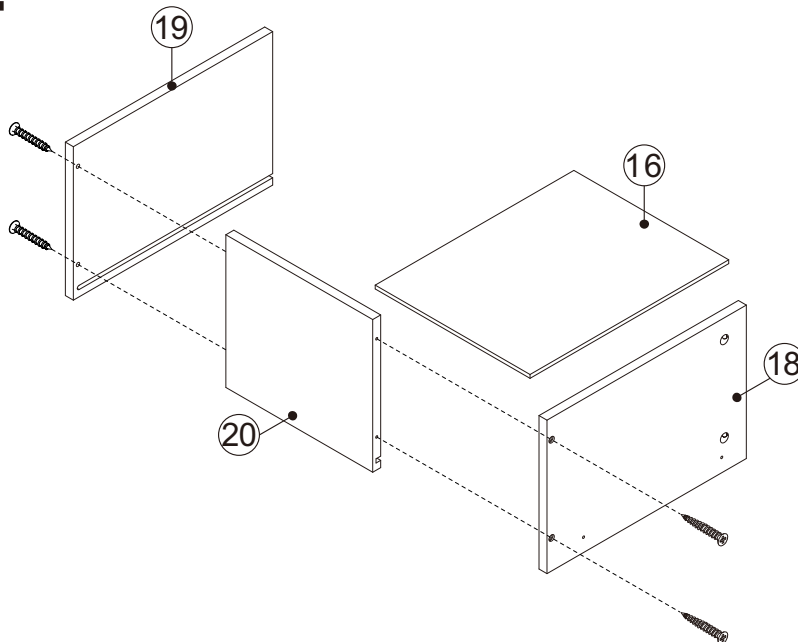
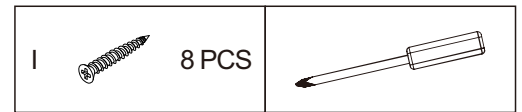

**x2**

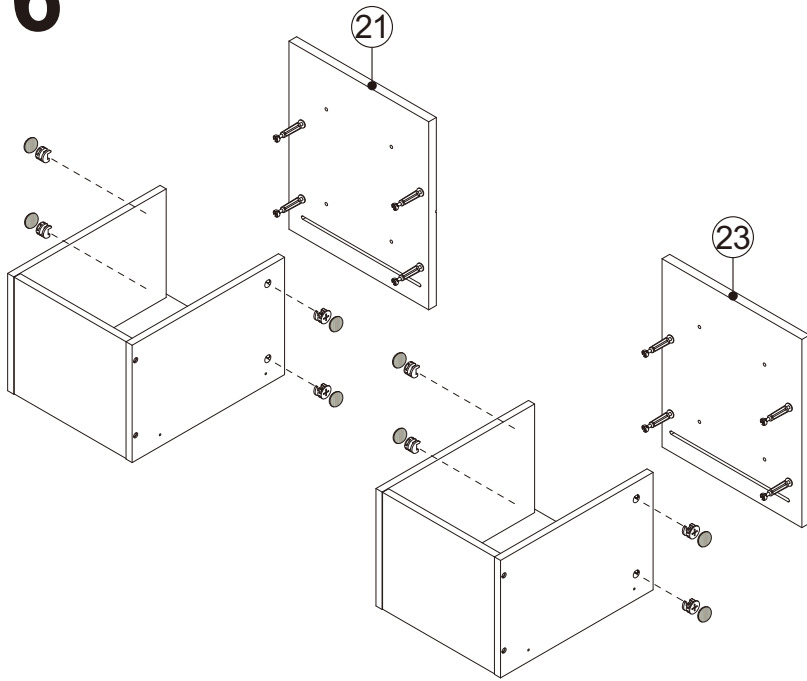

- Refer to the illustration,
  1. Connet the #18, #19, #20 together with screws.
  2. Insert the #16 into the assembled board.

# 16

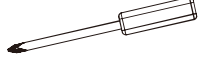



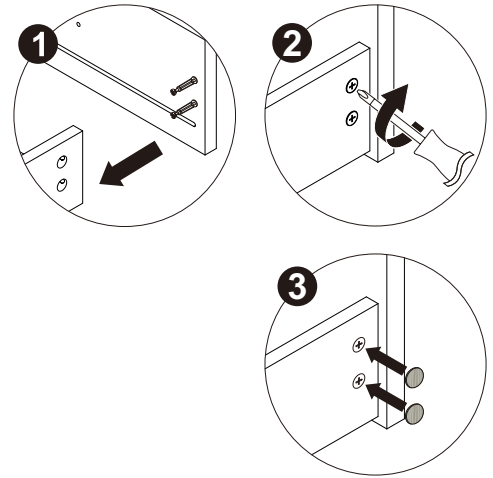

C		8 PCS	
O		8 PCS	

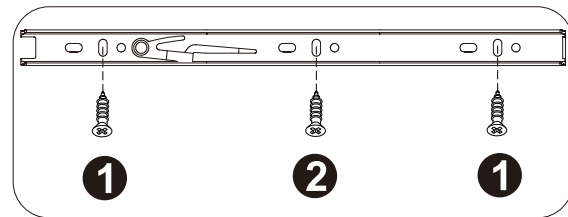

- Refer to the illustration, the drawer panel #21, #23 is insert into the assembled board. Then tighten the cam lock with the cover.

# 17

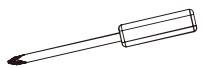

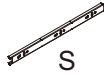
K		8 PCS	E		12 PCS	
M		4 PCS	F		4 PCS	

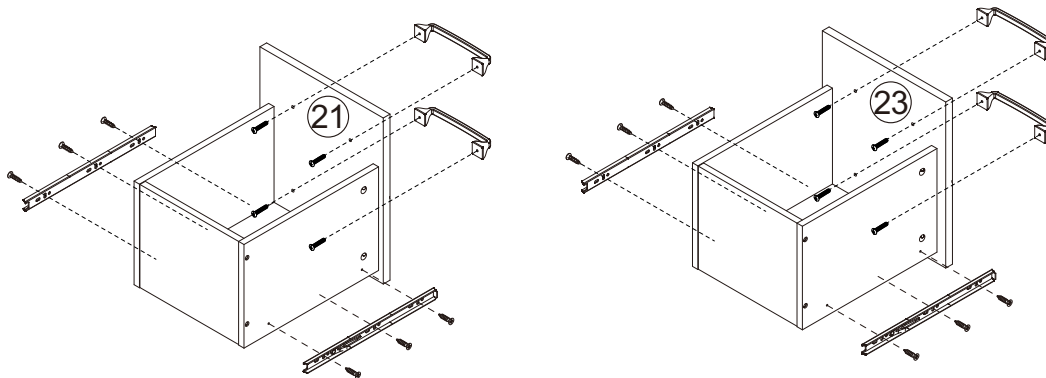

- Refer to the illustration, apply screws to fix the slides on the boards. Then use screws to installation the handle on the drawer panel.

# 18

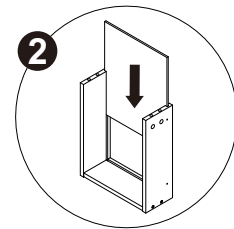
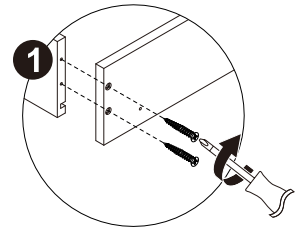
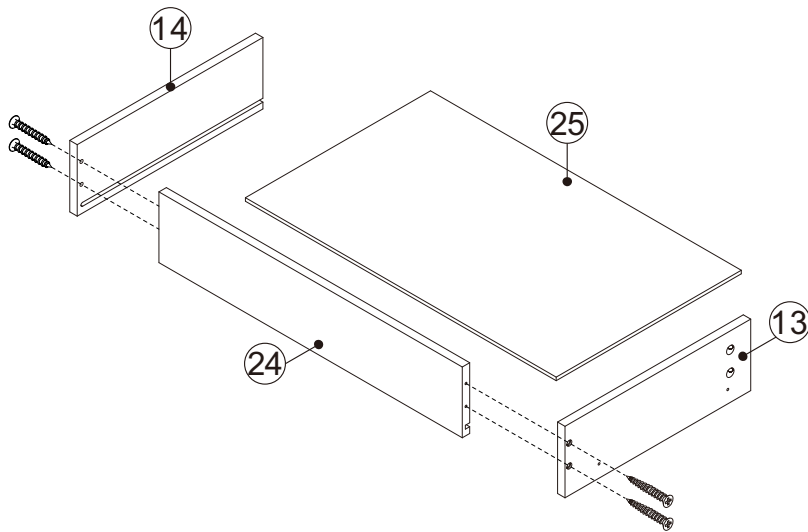



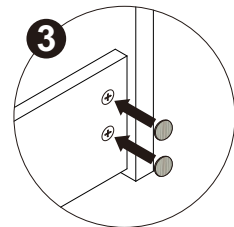
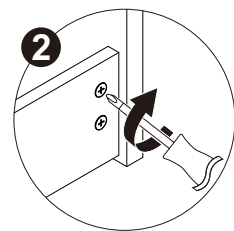
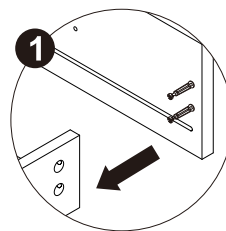
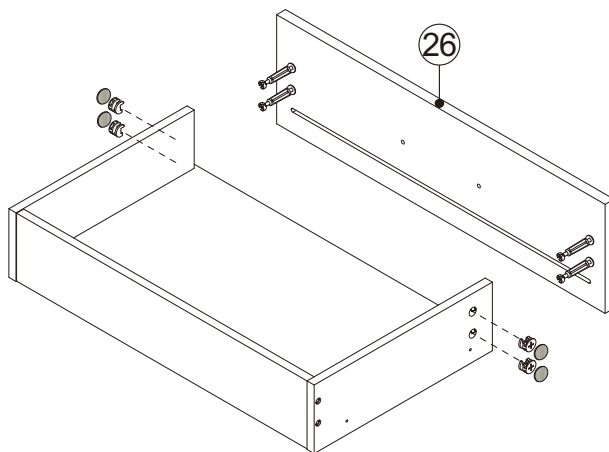
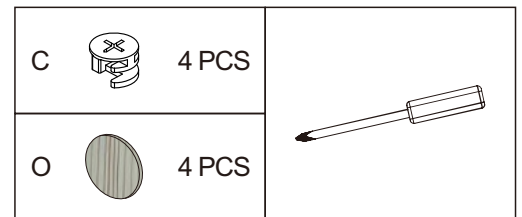

- Refer to the illustration,
  1. Connect the #13, #14, #24 together with screws.
  2. Insert the #25 into the assembled board.

# 19



- Refer to the illustration, the drawer panel #26 is inserted into the assembled board. Then tighten the cam lock with the cover.

# 20

K		2 PCS	E		6 PCS
M		1 PCS	F		2 PCS

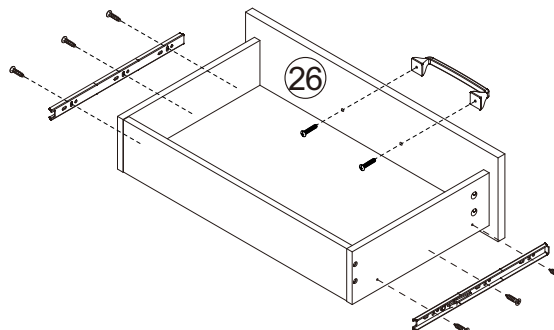
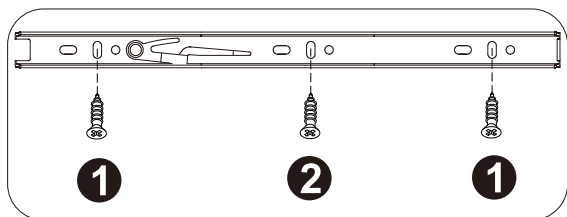
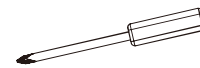

- Refer to the illustration, apply screws to fix the slides on the boards. Then use screws to installation the handle on the drawer panel.

# 21

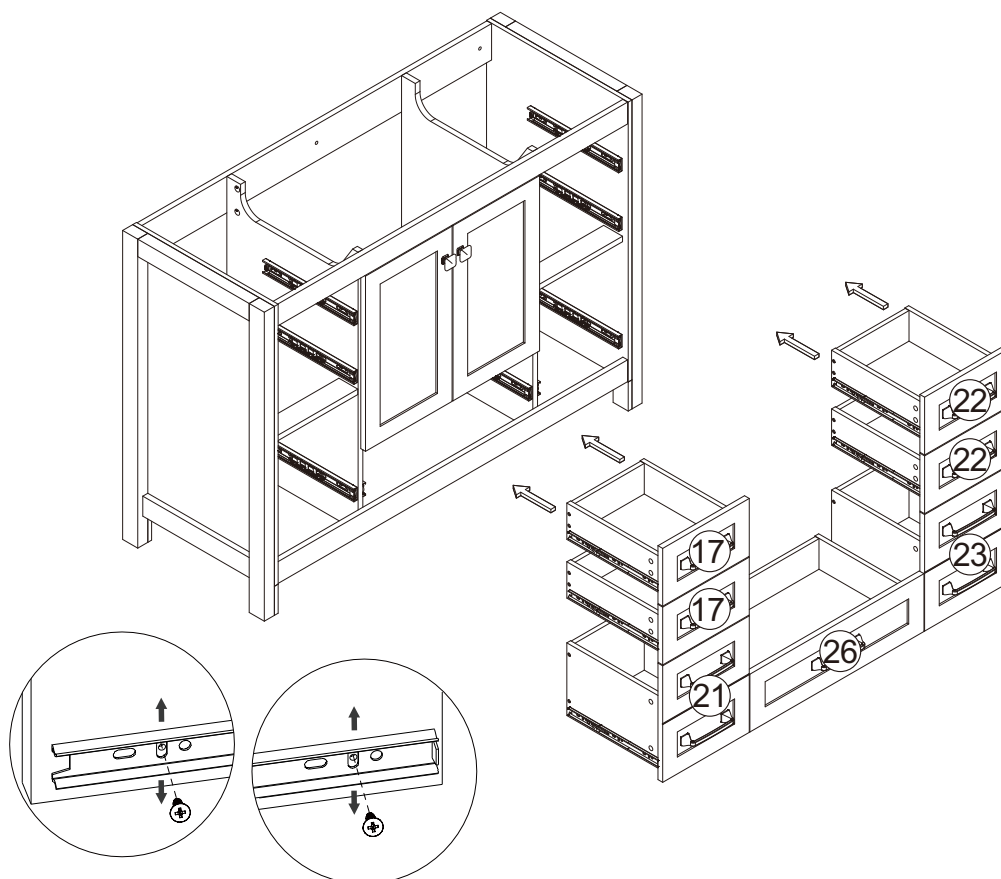

- If the drawers are not in the same level, please adjust the screws in the drawer box.
- Assembled drawers are loaded onto cabinets.

# THANK YOU

Thank you for choosing our product. We sincerely hope that the assembly process has been smooth and enjoyable for you. If you have any questions or suggestions during the use of the product, please feel free to contact us.

Contact number: (323)-393-8260 at EST 9AM-1PM

E-mail: [service@eclifeusa.com](mailto:service@eclifeusa.com)

