

Assembly Manual

Counter & Bar Height Swivel Stool

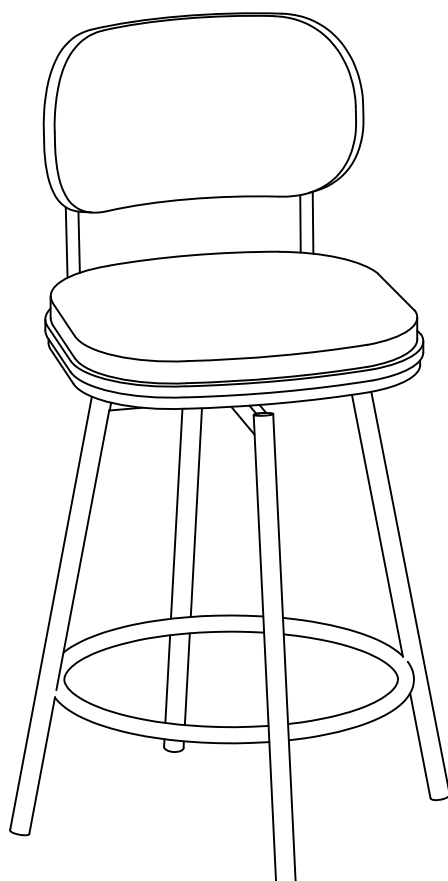







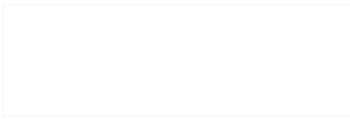

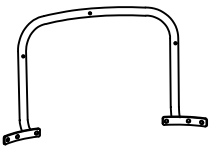

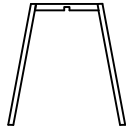
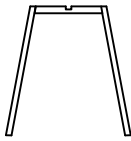
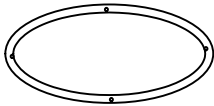
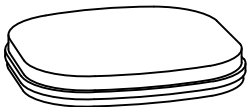
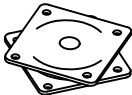

CAUTION

THIS ASSEMBLY MANUAL CONTAINS IMPORTANT SAFETY INFORMATION.

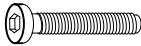
PLEASE READ AND KEEP FOR FUTURE REFERENCE.

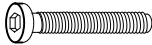

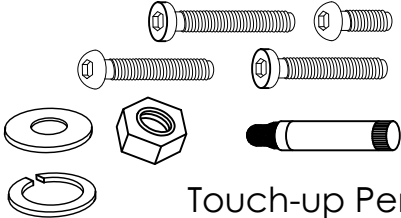
A X 1  Metal Back Bracket	B X 1  Wood Back Panel	C X 1  Leg
D X 1  Leg	E X 1  Footrest	F X 1  Seat Cushion
G X 1  Swivel Plate	H X 1  Allen Wrench (M4)	I X 1  Open-Ended Wrench
J X 6  Spring Washer	K X 12  Flat Washer	L X 6  Nut (φ 1/4")
M X 8  Bolt (φ 1/4" x 12mm)	N X 3  Bolt (φ 1/4" x 30mm)	O X 4  Bolt (φ 1/4" x 30mm)
P X 6  Bolt (φ 1/4" x 35mm)	Q X 4  Felt Pads (φ 19mm)	Extra Hardware  Touch-up Pen

Please read through the instructions below to familiarize yourself with the parts and steps before assembly.

Make sure all parts and hardware are present before assembly.

Note: Do NOT use power tools for assembly.

ASSEMBLY INSTRUCTIONS

Note: Assemble on a soft and smooth surface to prevent damage to product finish. Do not overtighten bolts to avoid stripping.

- 1 Connect Leg (C) and Leg (D) together. Attach Footrest (E) to stool base, using Bolts (O) and Allen Wrench (H).

Note: Do not fully tighten bolts.

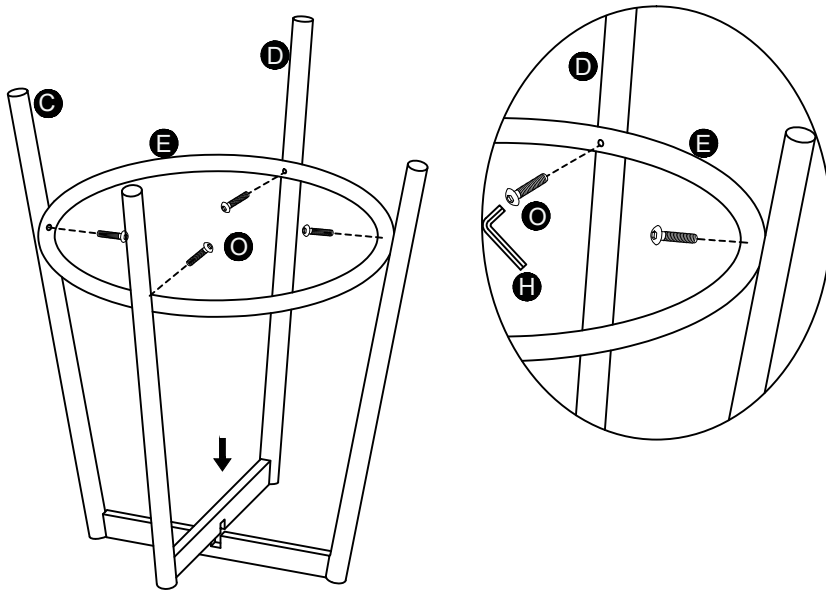

- 2 Attach Swivel Plate (G) to assembled stool base in Step 1, using Bolts (M). After all 4 bolts are attached, use Allen Wrench (H) to tighten.

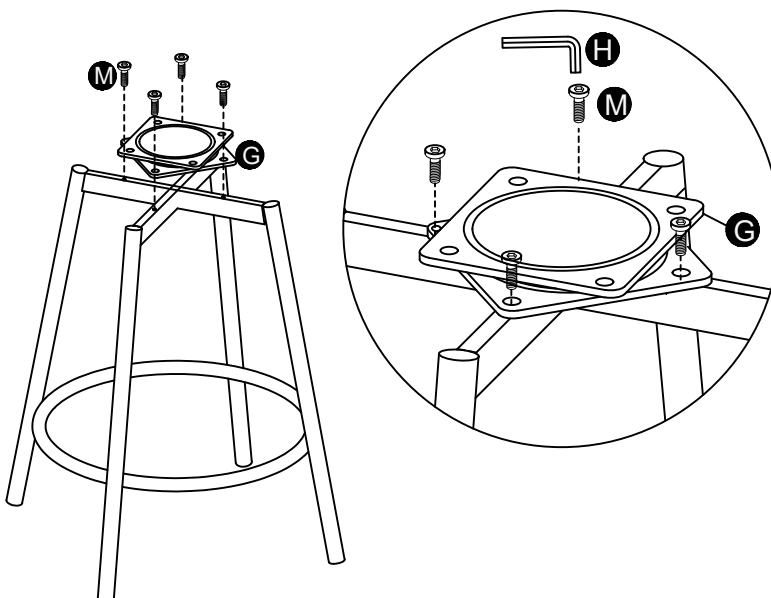

3 Attach Metal Back Bracket (A) and Wood Back Panel (B) together, using Bolts (N). After all 3 bolts are attached, use Allen Wrench (H) to tighten.

Note: 1. Please pay attention to the direction of the Wood Back Panel (B). Note: 2. Do not fully tighten bolts.

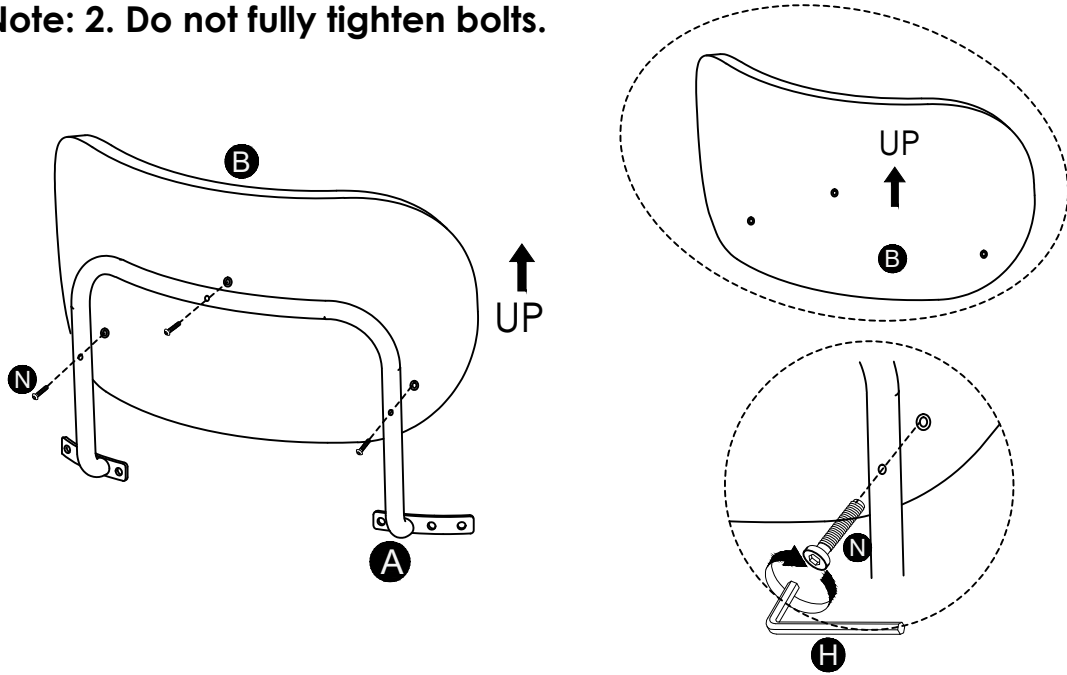

4 Attach Metal Back Bracket (A) to Seat Cushion (F), using Bolts (P), Flat Washers (K), Spring Washers (J), Nuts (L), Allen Wrench (H), and Open-Ended Wrench (I).

Note: Do not fully tighten bolts.

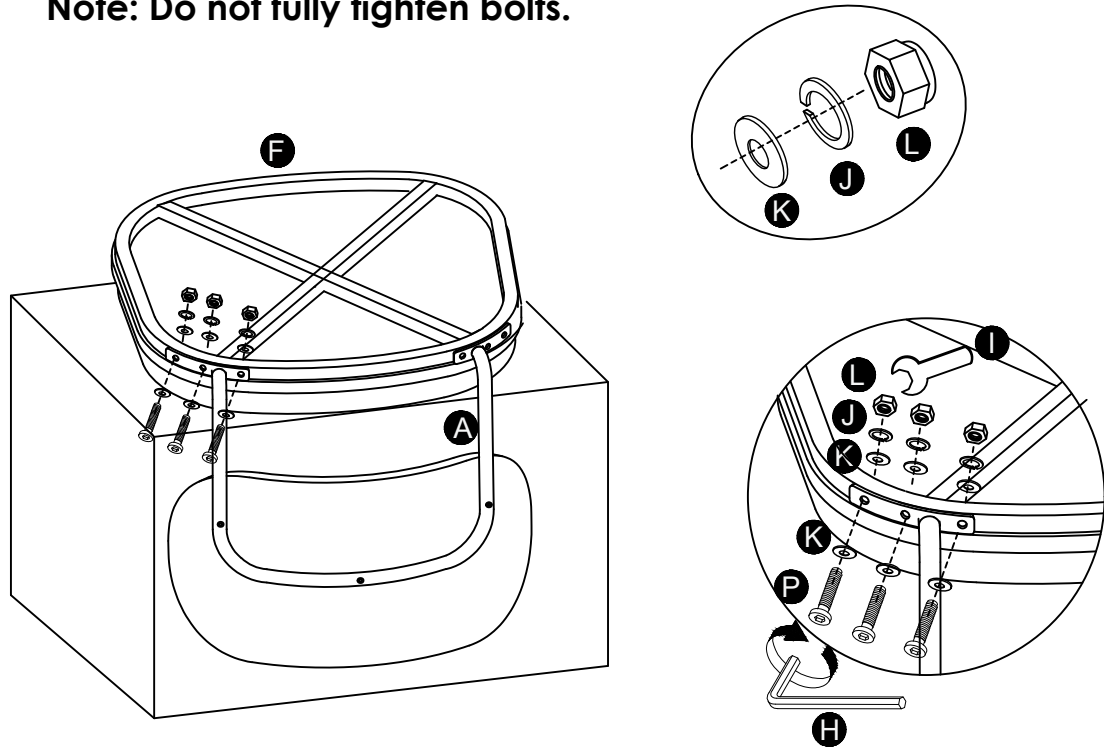

-
- 5** Attach assembled stool base in Step 2 to assembled seat in Step 3, using Bolts (M). After all 4 bolts are attached, use Allen Wrench (H) to tighten. Fully tighten bolts.

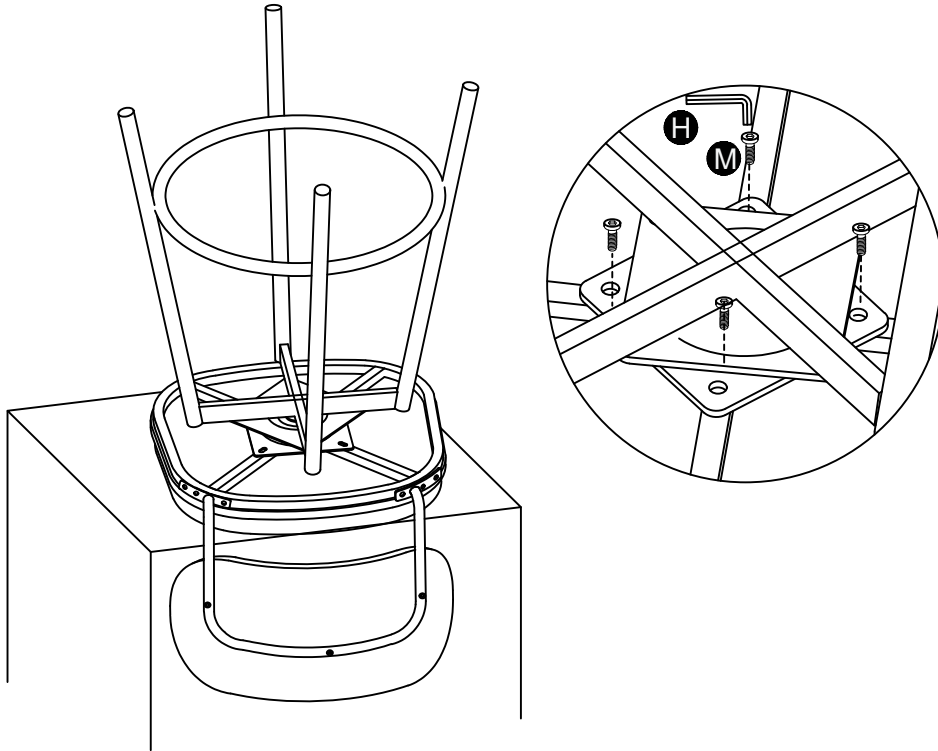

- 6** Put assembled stool on a flat surface. Push legs up or down as necessary to level. **Once level, tighten all bolts.**

Note: Each leg has an adjustable foot leveler to help level your chair.

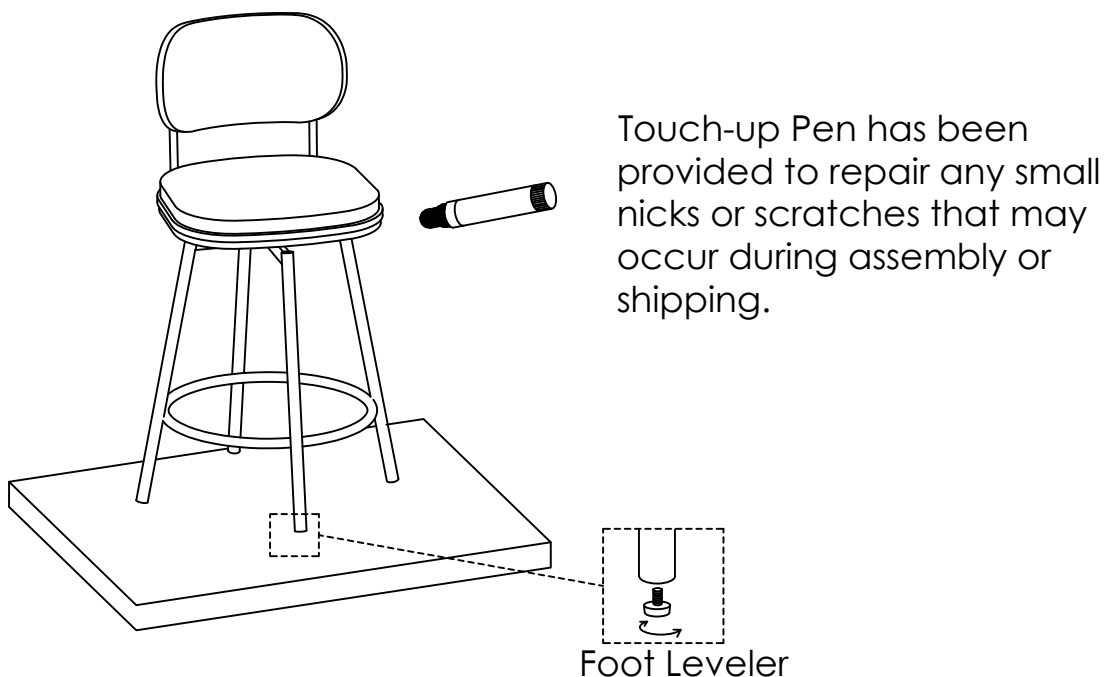

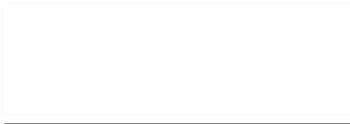

7

Complimentary Felt Pads (Q) are included to help protect your floor or make the chair slide easier. If needed, attach the complimentary Felt Pads (Q) to the leg.

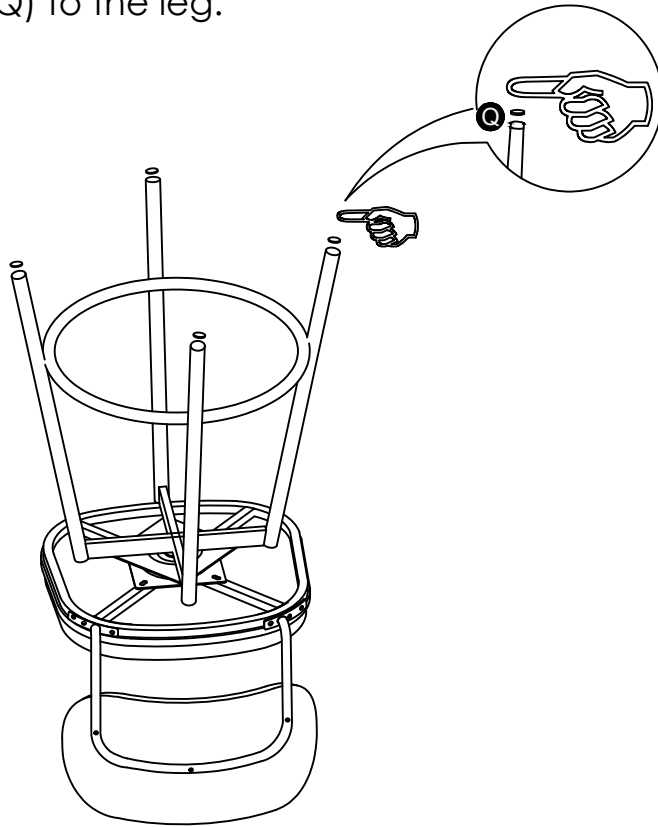

8

Assembly complete. Enjoy.

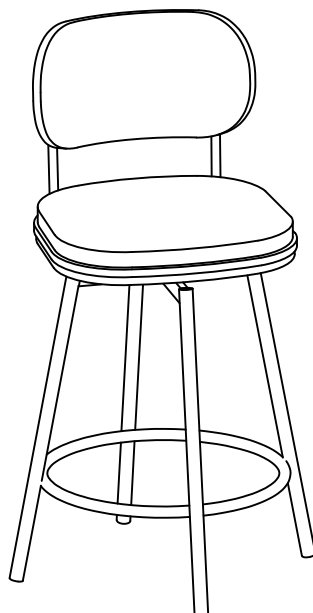

PRODUCT WARRANTY

- 1-year limited on cover against splitting, peeling, and/or tearing.
- 1-year limited on internal and external frame structure.
- 1-year limited on cushioning material, seat springs and mechanism.

CARE & MAINTENANCE

Water Based Cleaner 'W': Spot clean using the foam only from a water-based cleaning agent such as a mild detergent or non-solvent upholstery shampoo product. Apply foam with a soft in circular motion.

Vaccum when dry.

Do not place furniture in direct sunlight and keep furniture at least 60 cm / 2 feet from heat sources to avoid fading.