

Assembly Instructions

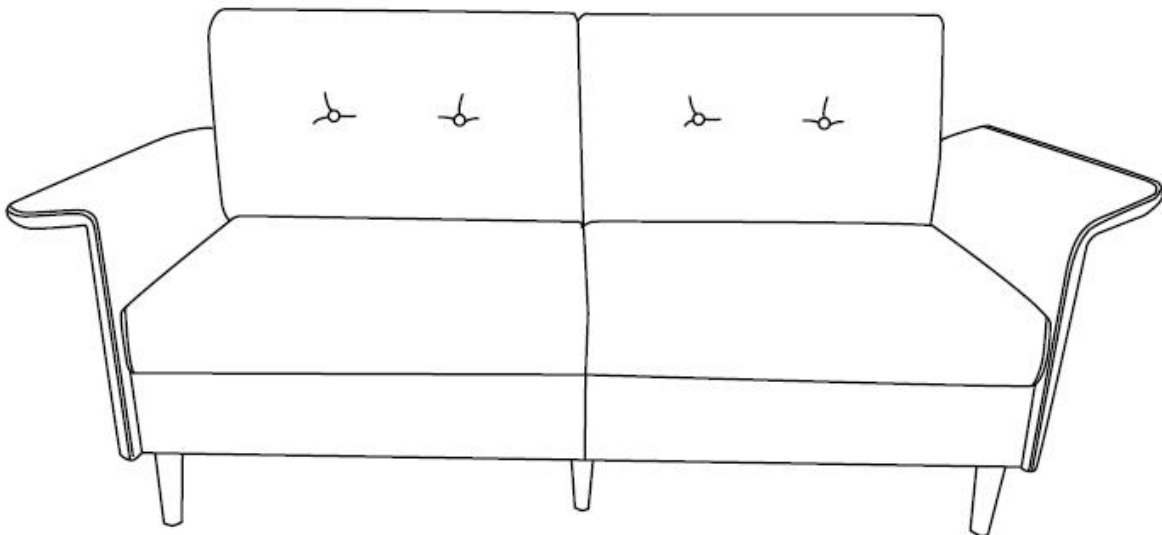



CAUTION : You must read this before you proceed

Please look in the magic tape pouch for hardware packs and legs

3 SEATER SOFA

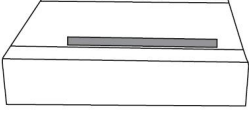
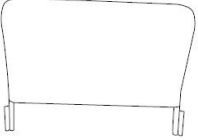

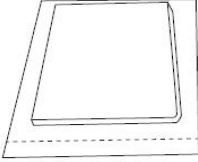
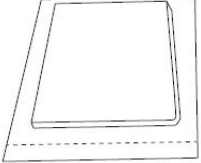





Parts List

Label	Picture	Description	QTY
A		Seat Frame	2
B		Backrest	2
C1		Right Armrest	1
C2		Left Armrest	1
D		Back Cushion (Package)	2
E		Seat Cushion (Package)	2
F		Leg	6

Hardware

Label	Picture	Description	QTY
①		Bolt(M8*60MM)	5
②		Screw Arbor (M8*70MM)	9
③		Flat Washer	17

④		Spring Washer	17
⑤		Allen Wrench	1
⑥		Nut	13
⑦		Spanner	1
⑧		Connecting Piece	2
⑨		Plastic Washer	9

Assembly Preparation

Before Beginning Assembly:

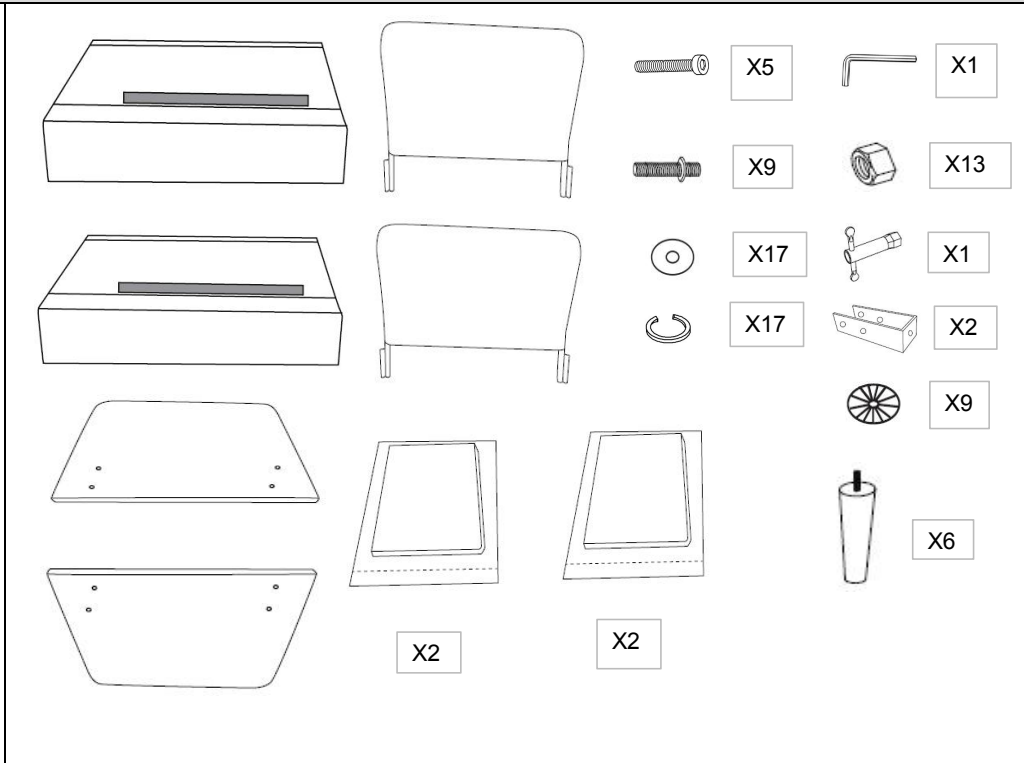

Diagram illustrating the assembly preparation steps and required parts:

- 5 screws (X5)
- 1 Allen wrench (X1)
- 9 bolts (X9)
- 13 nuts (X13)
- 17 plastic washers (X17)
- 1 spanner (X1)
- 2 connecting pieces (X2)
- 9 plastic washers (X9)
- 6 tubes (X6)



- Read instructions, cover to cover-



- Have 2 adults on hand for assembly-



- Do not assemble on flooring or carpet-



- Assemble on a clean non-marring surface (packing foam)-



- Save all packaging until finished-

Assembly Steps

OVERVIEW

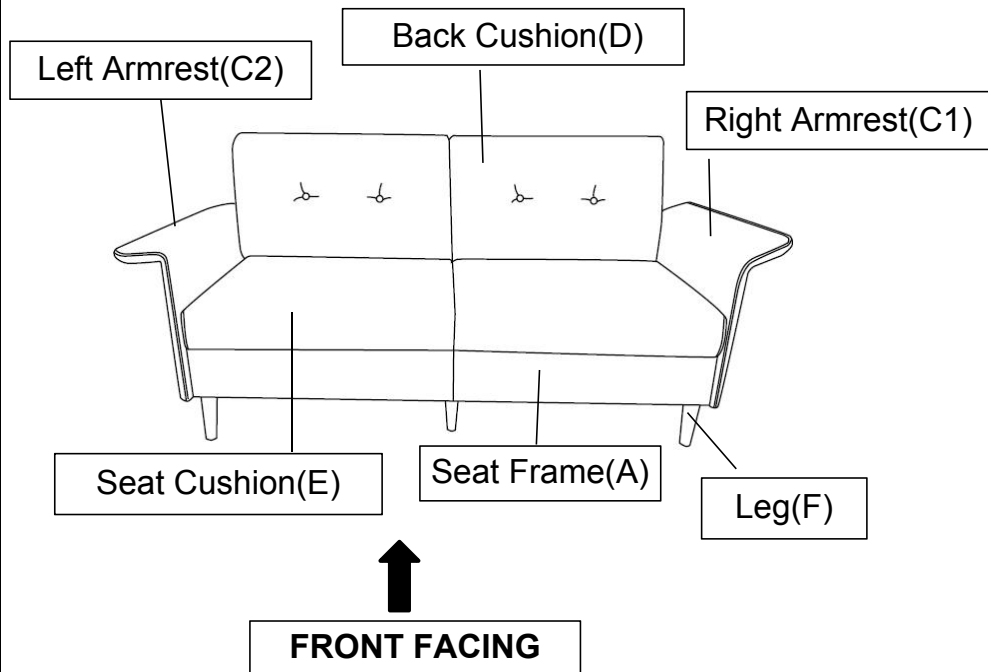

This 3 Seater Sofa has multiple parts and may require up to 60 minutes to assemble. To give you an overview of the 3 Seater Sofa parts, the above picture is to help you put the various parts into perspective. Please read through the instructions herebelow to familiarise the parts and steps before assembly.

Step 1

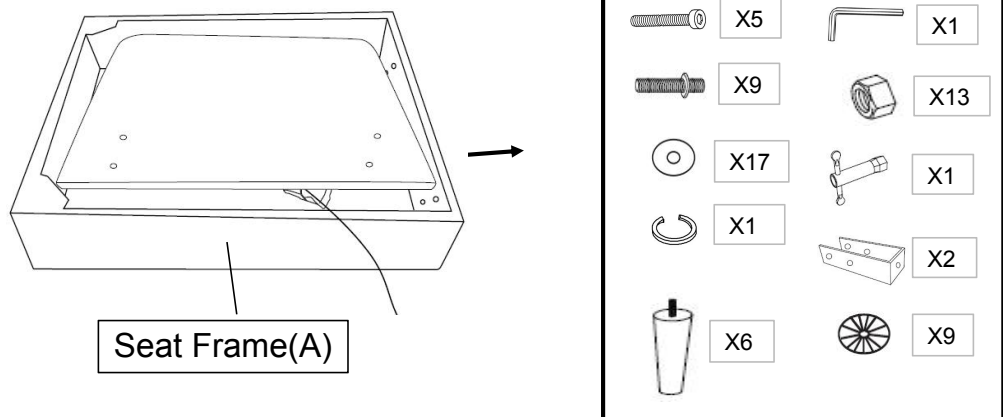

Open the carton and place all the parts on a clean, non-marring surface. Remove the hardware package from the Seat Frame(A) as shown above.

Step 2

Step 2.1

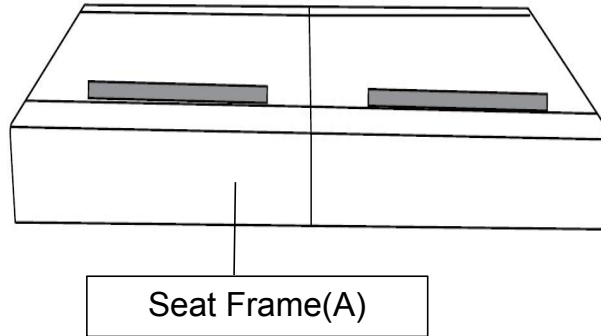

Step 2.2

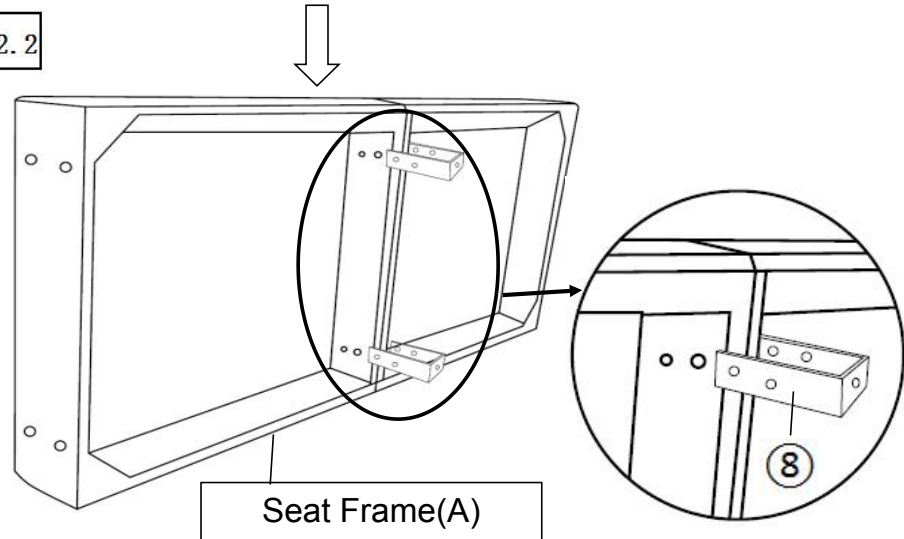

Step 2.1 Put two Seat Frame(A) together then turn bottom up.

Step 2.2 Connect two Seat Frame(A) with Connecting Piece(8) as shown above.

Step 3

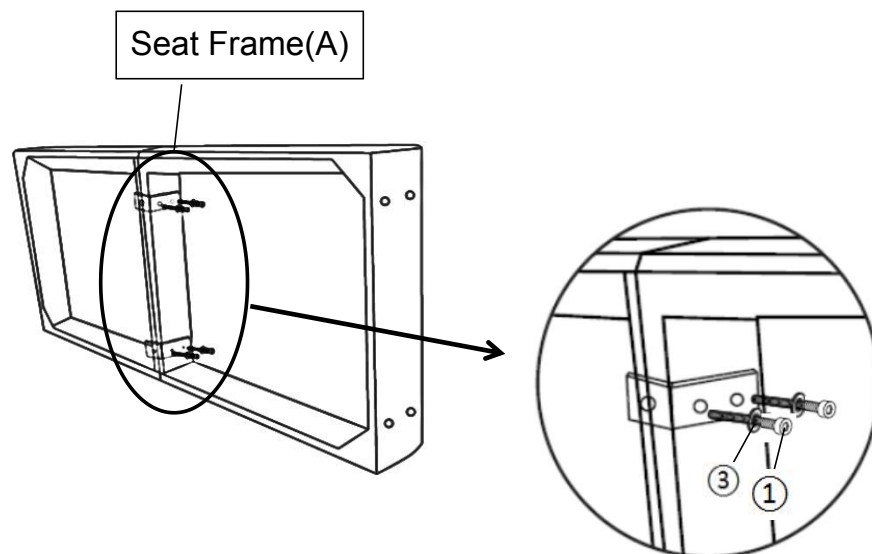

Align the mounting positions on two the Seat Frame(A) .

Attach the two Seat Frame(A) using Bolt(1), Flat Washer(3), Screw the Bolt(1) into mounting position on the two Seat Frame(A) with your hand first, as shown.

Step 4

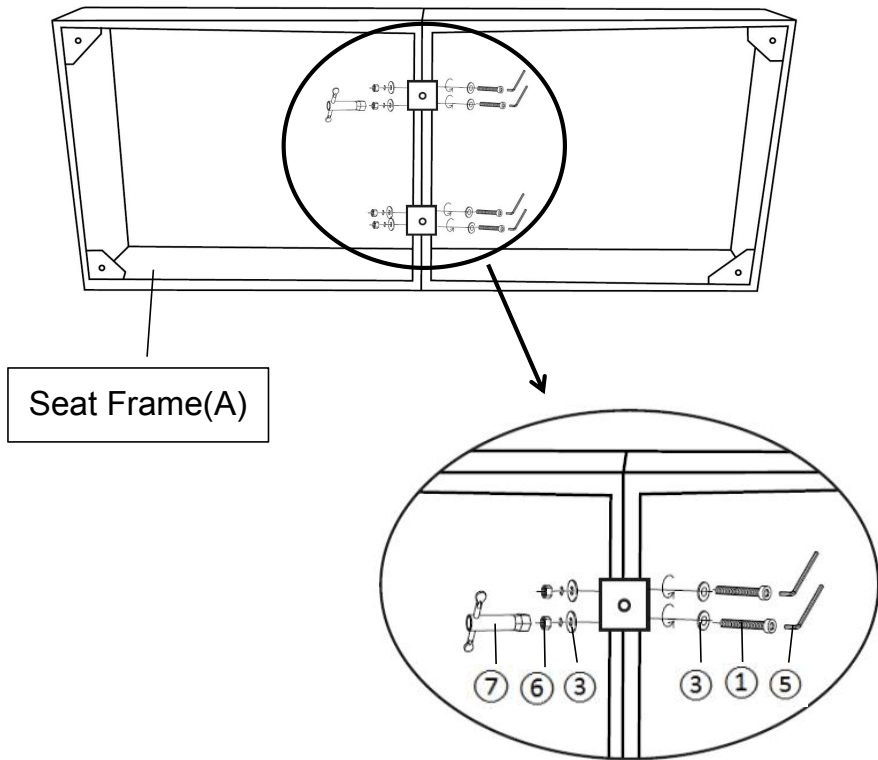

After the Step 3, place the Nut(⑥), Flat Washer(③), and Spanner(⑦) as the picture shown, and then turning the Allen Wrench(⑤) clockwise while holding Spanner(⑦) until tight as shown. Ensure all Bolt(①) are tightly and securely attached.

Step 5

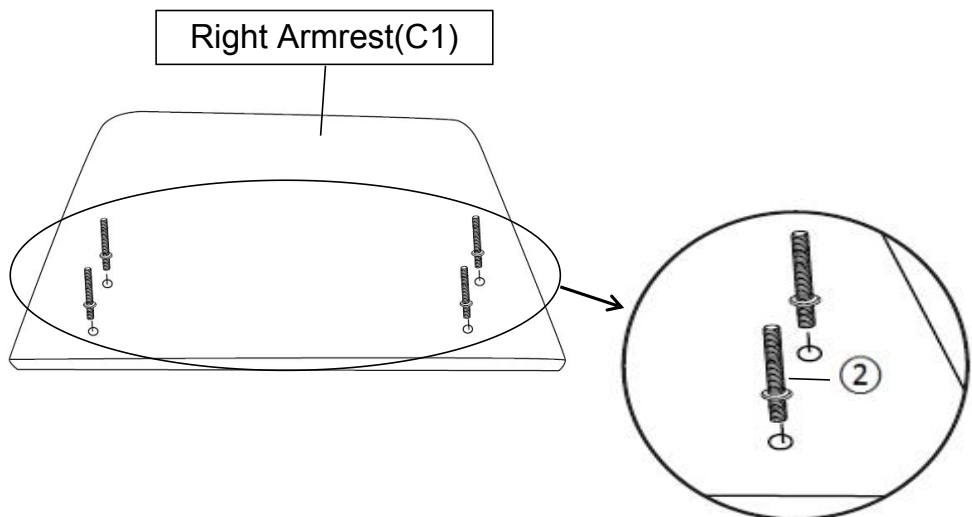

Screw the Screw Arbor(②) into mounting position on the Right Armrest(C1) by hand until tight.

Repeat the same step to finish Left Armrest(C2).

Step 6

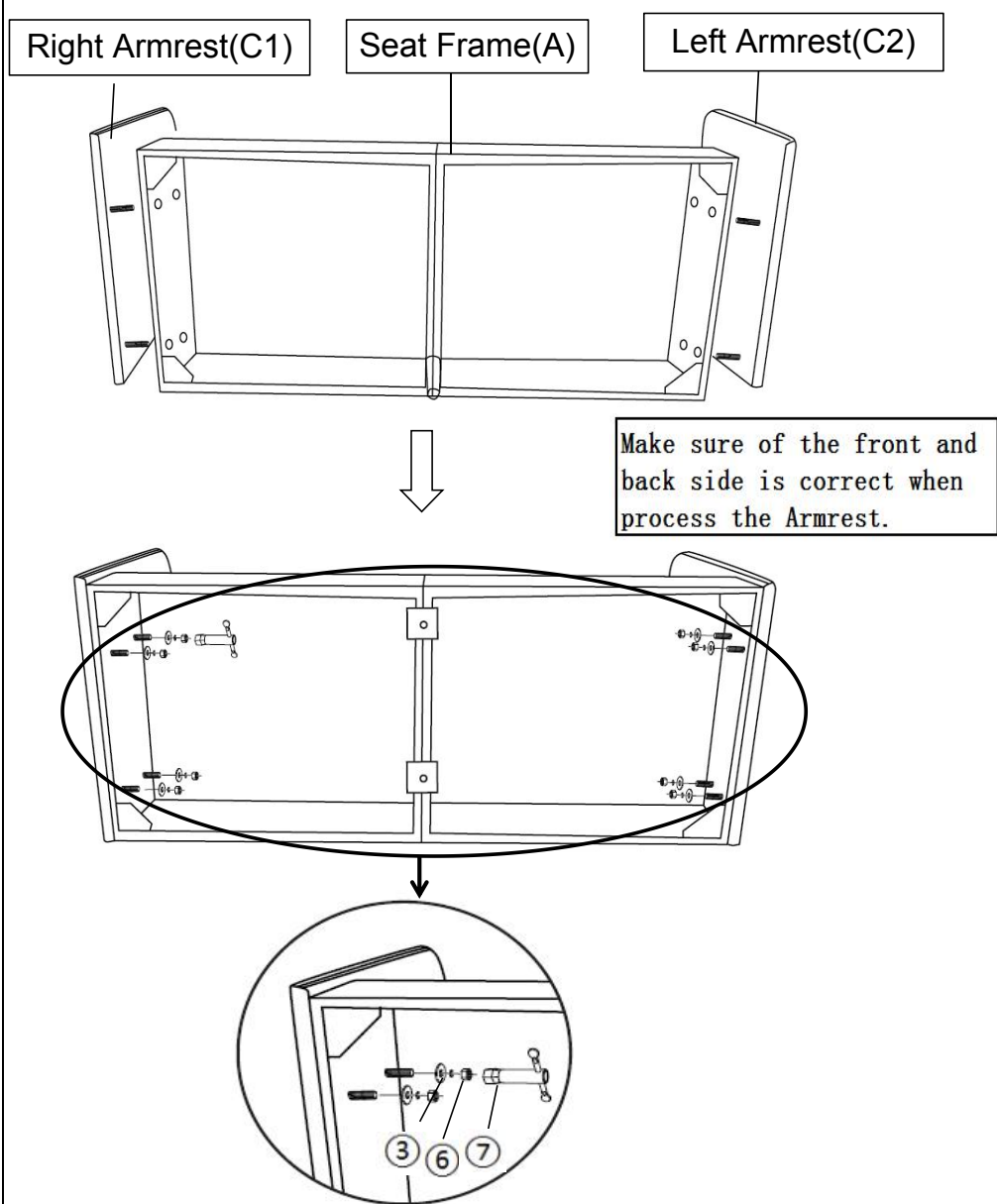

After the Step 5, install the Right Armrest(C1) and Left Armrest(C2) to the Seat Frame(A) using Nut(⑥), Flat Washer(③) with Spanner(⑦), turning clockwise until tight.

Step 7

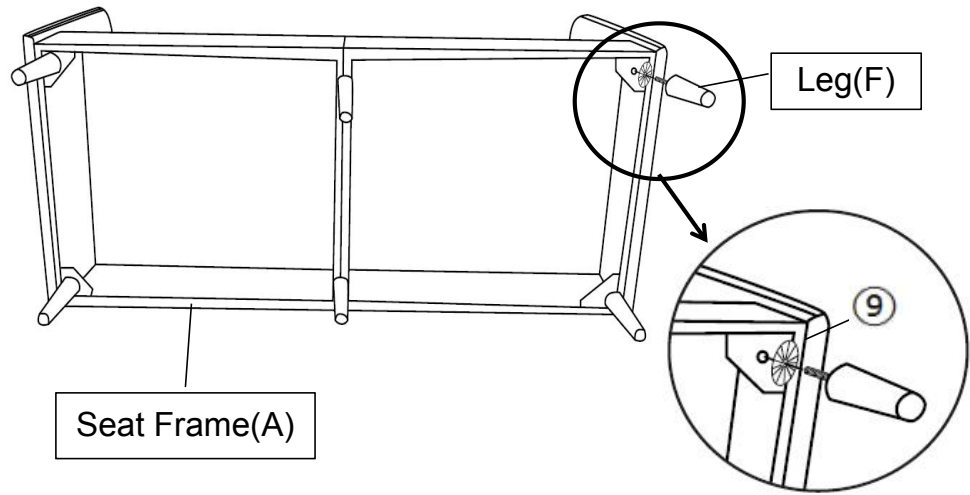

Install the Leg(F) to Seat Frame(A) by placing a Plastic Washer(9) onto the threaded stem of the Leg. Turn clockwise the leg by hand until tight. Repeat the same step to finish remaining legs.

Note: The use of Plastic Washer(9) are OPTIONAL and are especially useful to help alleviate slight wobbles. Some Legs may need more than one Plastic Washer(9) whilst some Legs may not need any. Position Sofa right side up and test for stability on a Level Surface. Add or remove Plastic Washer(9) where needed to achieve stability.

Step 8

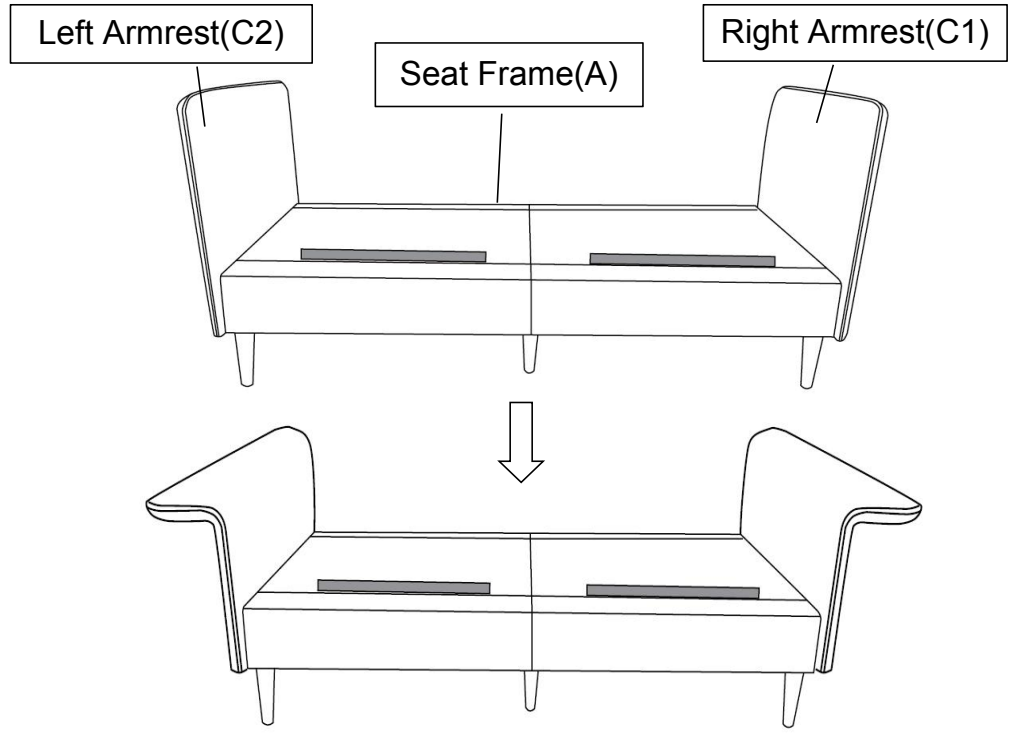

Folding the Right Armrest(C1) and Left Armrest(C2) by hand as shown above.

Step 9

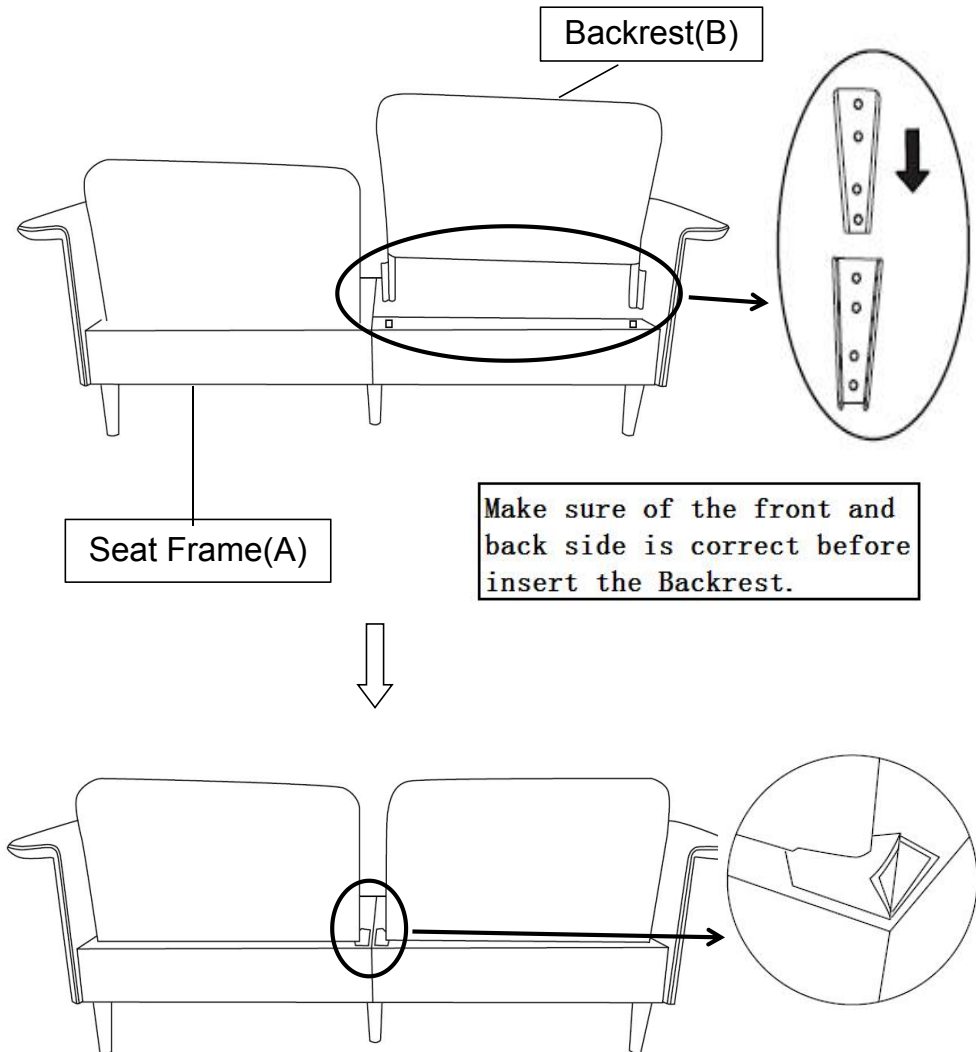

Standing behind the Seat Frame(A) while holding the Backrest(B),insert Backrest(B) into Seat Frame(A),Firmly but gently,then cover the hole site with the fabric.

Note: Make sure the Insert of Backrest(B) lock into the Insert on the Seat Frame(A).

Caution: Ensure that your fingers do not get caught or pinched in the assembly process.

Step 10

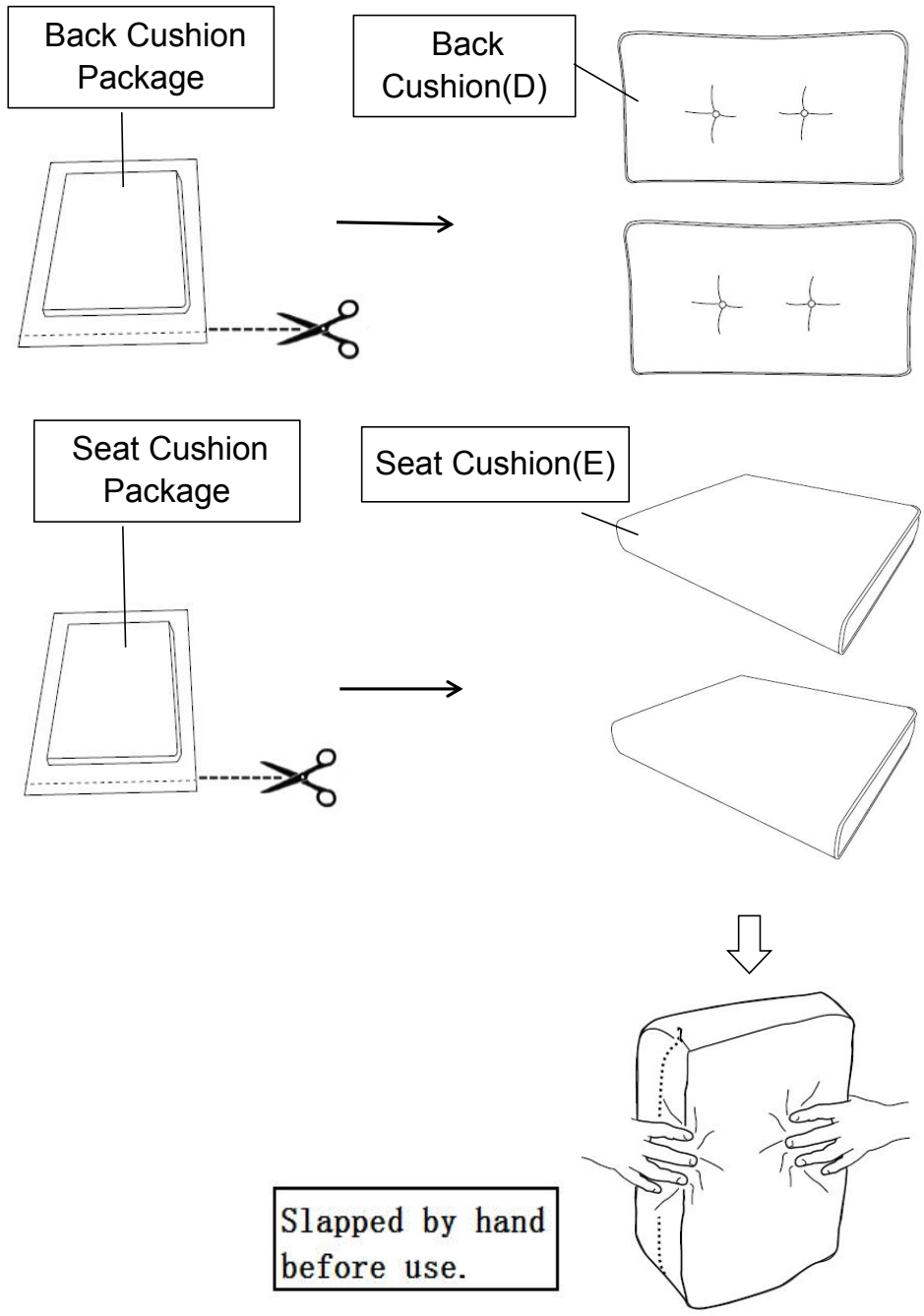

Open the Back Cushion Package and Seat Cushion Package along the side and take out two pieces Back Cushion(D) and two pieces Seat Cushion(E).

NOTE: Back Cushion(D) and Seat Cushion(E) are need slapped by hand and stay for a while before use.

Step 11

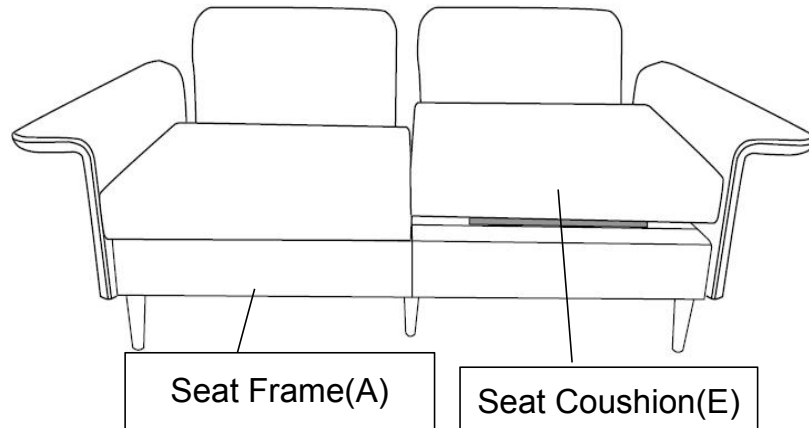

Put the Seat Cushion(E) on the Seat Frame(A).

Step 12

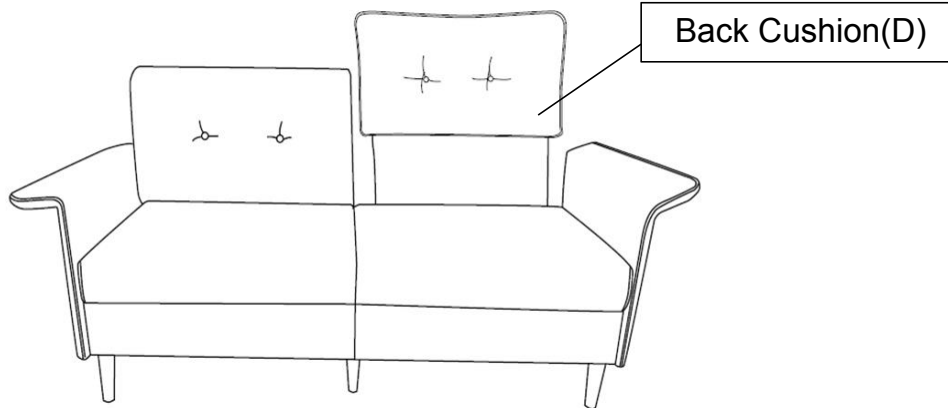

Put the Back Cushion(D) on the Seat Frame(A).

Step 13

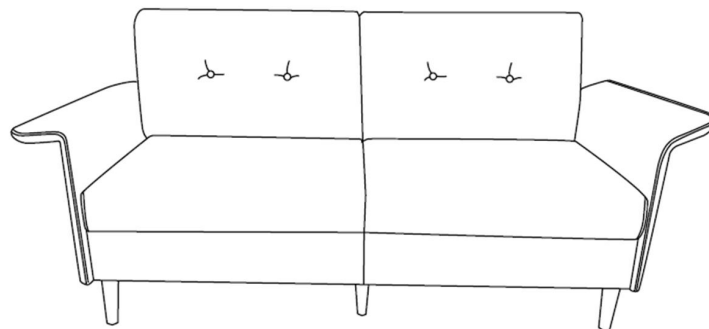

Your 3 Seater Sofa is ready for use.
This 3 Seater Sofa can only be used on a flat, level surface.

Care & Maintenance



- Furniture may scratch floors. We recommend using furniture pads to protect your floors.



- Do not put hot items directly on furniture surface.



- Do not clean furniture with harsh cleansers or polish.



- Do not place furniture under direct sunlight.



- Do not place furniture near heating or cooling vents.

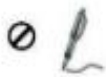

- Do not write on furniture without a padded barrier to protect the surface.



- Do not place furniture outside . For indoor use only.



- Not for commercial use. For residential use only.



- Stains may be removed with mild soap solution and damp cloth.

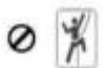

- Children should not climb or jump on the furniture.



- Dust and pick-up spills using a clean, non-colored, lint-free cloth.