

## Arched Display Cabinets

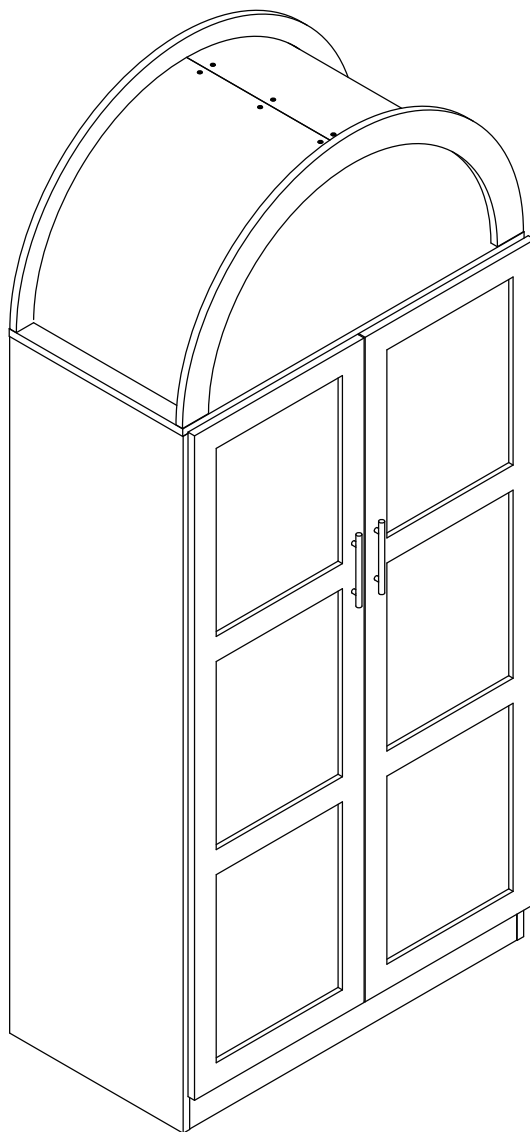

# NOTICE

---

**Please keep these instructions for future reference.**

**Dear Customer**

● Thank you for your purchase. When you receive the product, please make sure that all the parts are intact. If any parts are missing, please contact us promptly to request replacement parts.

● Then follow the entire installation instructions to install.

● Each part is crucial, so please be careful not to lose any. It is recommended to store parts with different lettered identifiers in separate boxes or bags to avoid confusion during installation.

**A .** The outer box is damaged

**B .** The product is damaged / bent / cracked while you open the box

**C .** The parts / accessories / assembly tools are missing

**D .** The instructions are not clear and can not be referred





**E .** The product has functional problems

**F .** Other aspects that you are not satisfied with

**Please feel free to contact us for help, and provide the following information:**

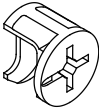
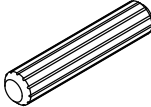
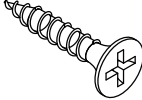
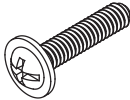
**Platform/Shop name|Order ID|buyer's name/ receiver's address/Problem description.**

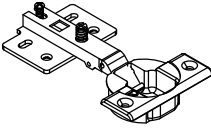
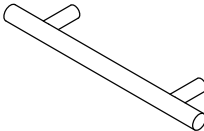
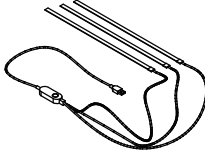
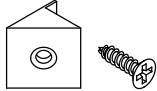
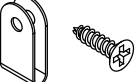
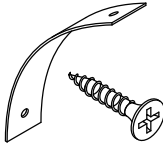
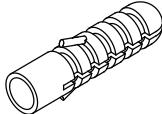
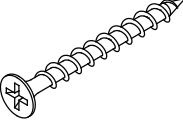
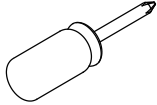
# EXPLODED VIEW

<p><b>A</b></p>  <p>7x35mm 47(+2)PCS</p>	<p><b>B</b></p>  <p>15x9.5mm 47(+2)PCS</p>	<p><b>C</b></p>  <p>16(+2)PCS</p>	<p><b>D</b></p>  <p>M3x15mm 42(+2)PCS</p>	<p><b>E</b></p>  <p>M4x18mm 4PCS</p>
<p><b>F</b></p>  <p>47(+2)PCS</p>	<p><b>G</b></p>  <p>6PCS</p>	<p><b>H</b></p>  <p>2PCS</p>	<p><b>I</b></p>  <p>1PC</p>	<p><b>J</b></p>  <p>14(+1)PCS</p>
<p><b>K</b></p>  <p>6PCS</p>	<p><b>L</b></p>  <p>2PCS</p>	<p><b>M</b></p>  <p>2PCS</p>	<p><b>N</b></p>  <p>2PCS</p>	<p><b>O</b></p>  <p>1PC</p>
<p><b>P</b></p>  <p>1PC</p>				

# EXPLODED VIEW

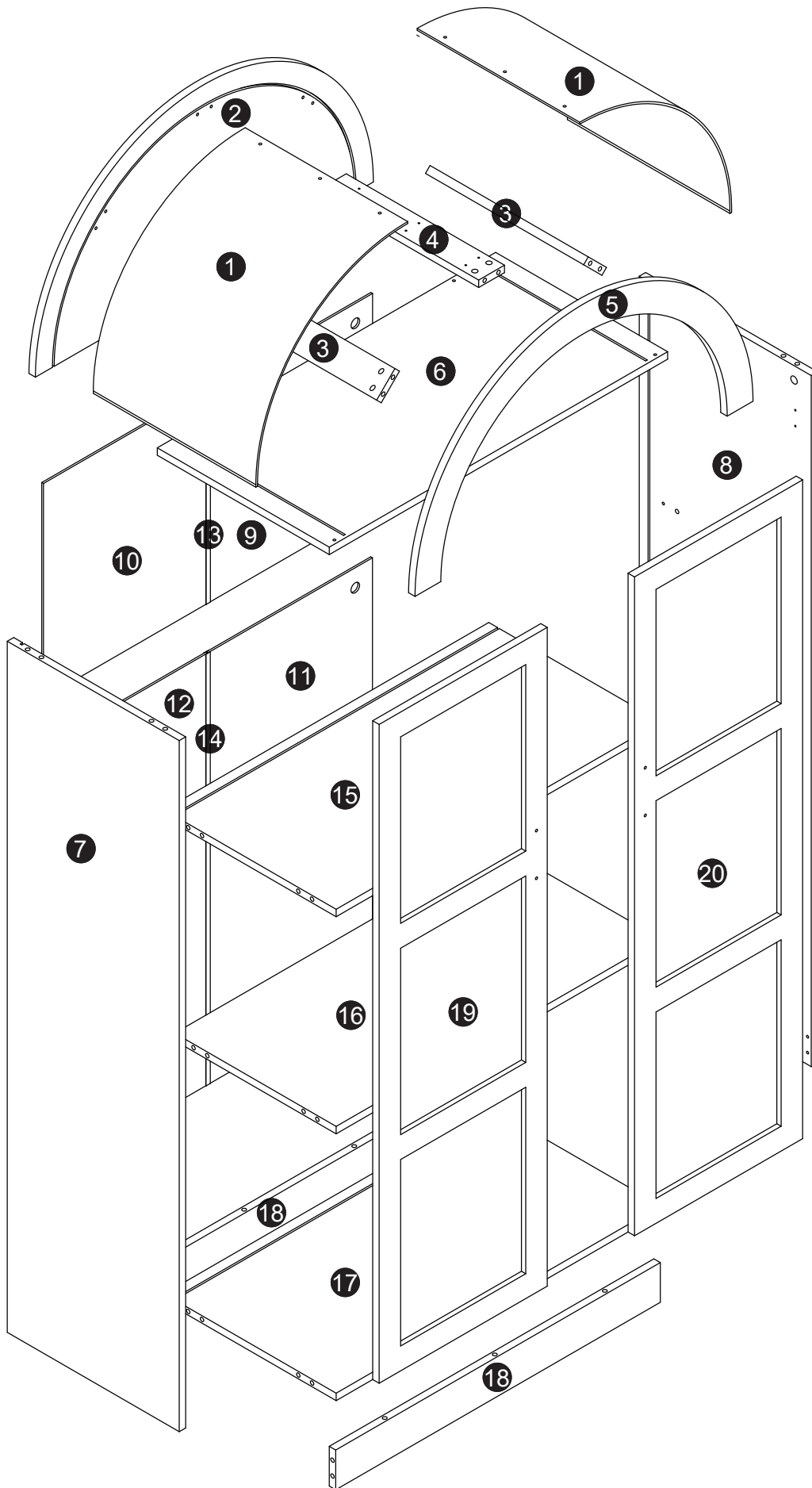

# STEP

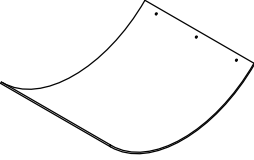
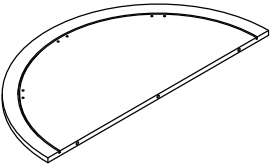
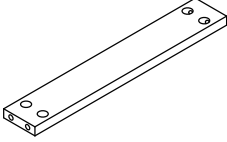
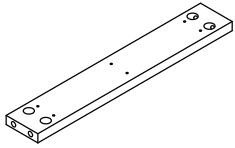
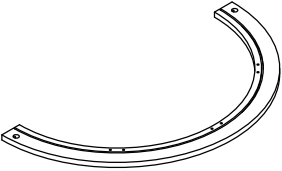
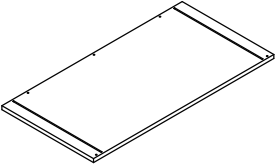
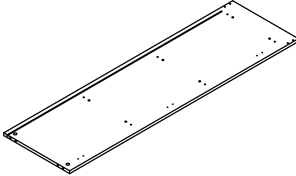
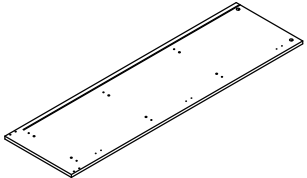
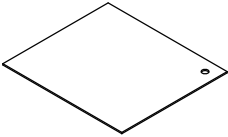
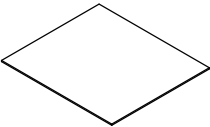
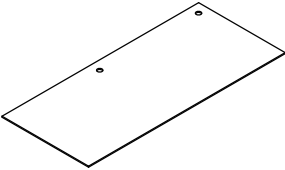
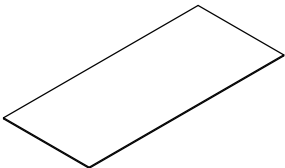
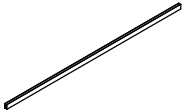
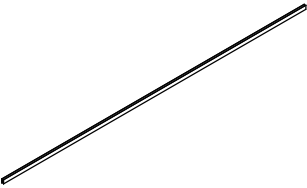
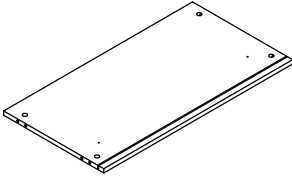
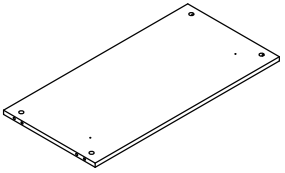
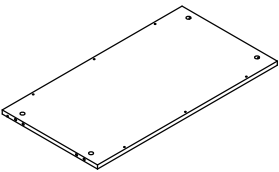
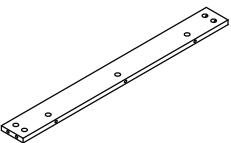
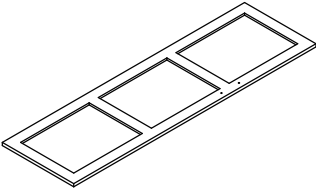
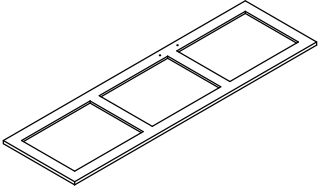
<b>1</b>  x2PCS	<b>2</b>  x1PC	<b>3</b>  x2PCS	<b>4</b>  x1PC
<b>5</b>  x1PC	<b>6</b>  x1PC	<b>7</b>  x1PC	<b>8</b>  x1PC
<b>9</b>  x1PC	<b>10</b>  x1PC	<b>11</b>  x1PC	<b>12</b>  x1PC
<b>13</b>  x1PC	<b>14</b>  x1PC	<b>15</b>  x1PC	<b>16</b>  x1PC
<b>17</b>  x1PC	<b>18</b>  x2PCS	<b>19</b>  x1PC	<b>20</b>  x1PC

# STEP

## Use the Cam Lock and Eccentric Wheel ECCENTRIC WHEEL

Tighten the bolt until the shoulder is aligned with the panel.  
Be sure not to tighten too much or too little.

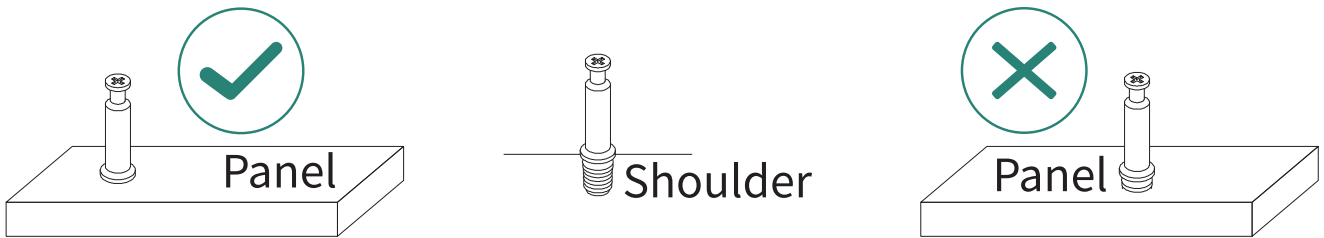

The pre-inserted nut should align with the center of the cam lock when joining two panels. The cam lock should be inserted before the eccentric wheel.

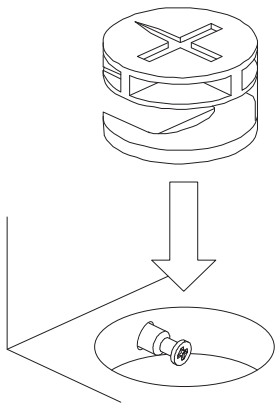

Turn the cam lock clockwise to tighten.

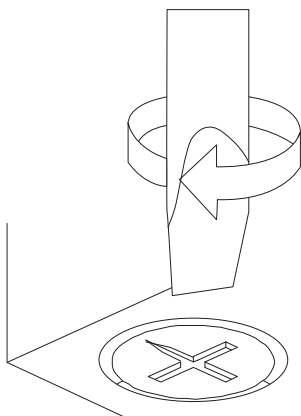

# STEP

01

Ax6

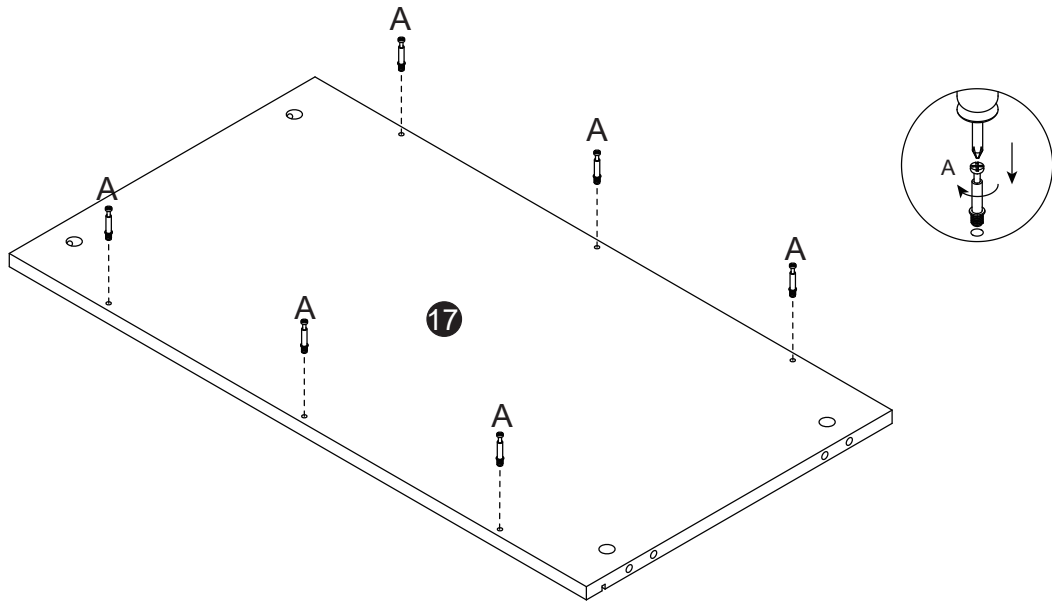

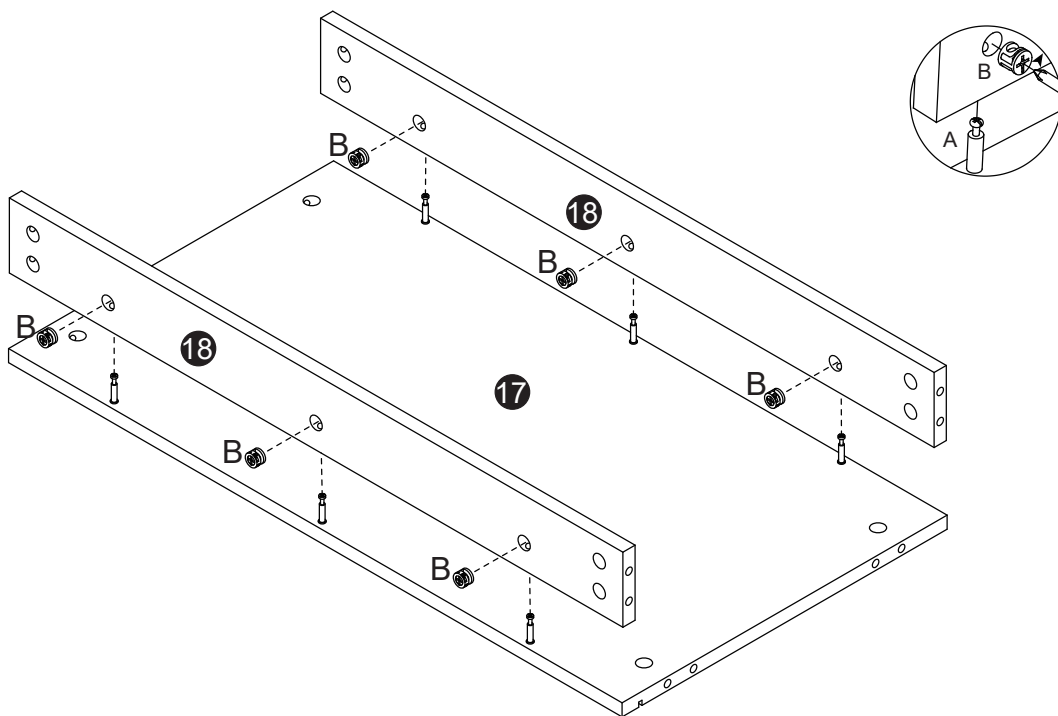

02

Bx6



# STEP

03

Ax10   
Cx6 

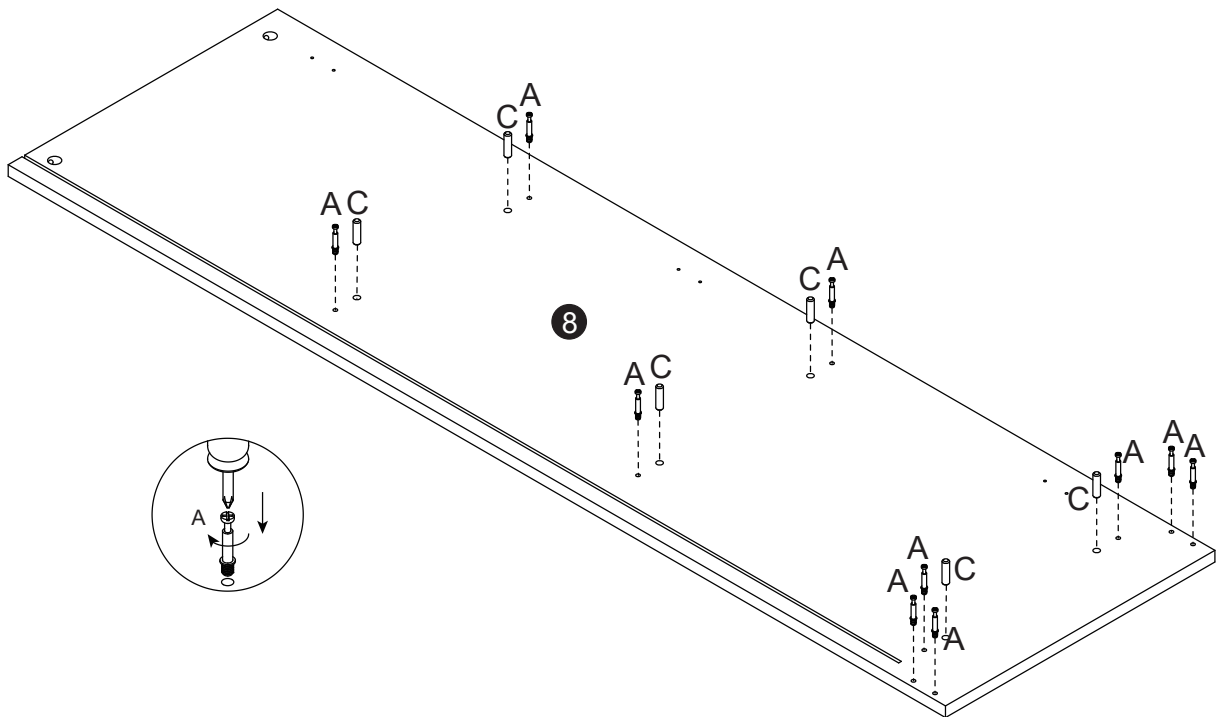

04

Bx10 

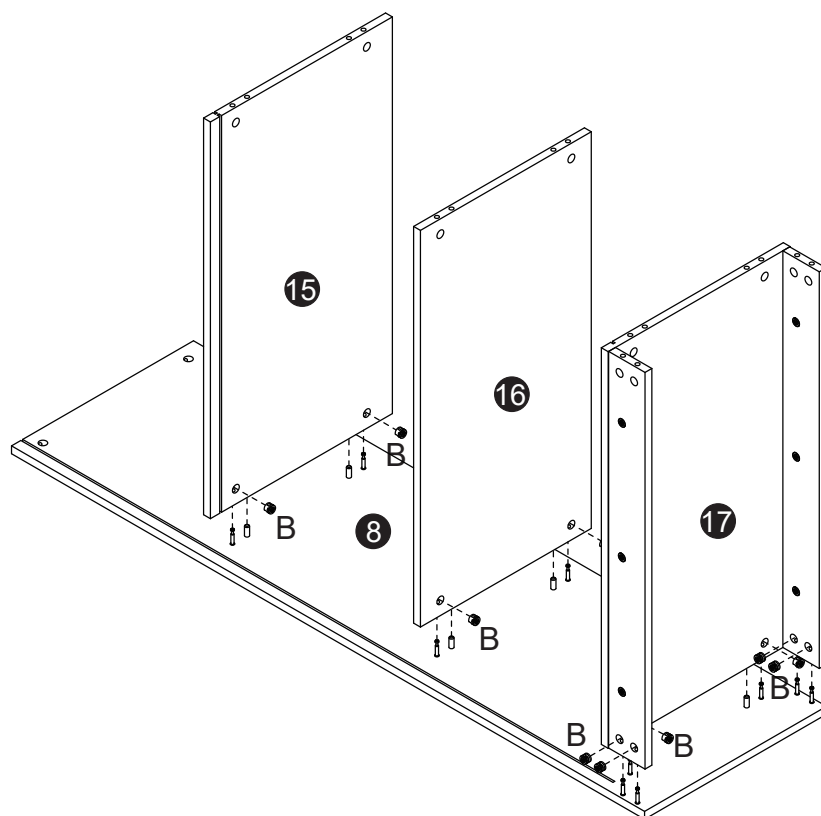

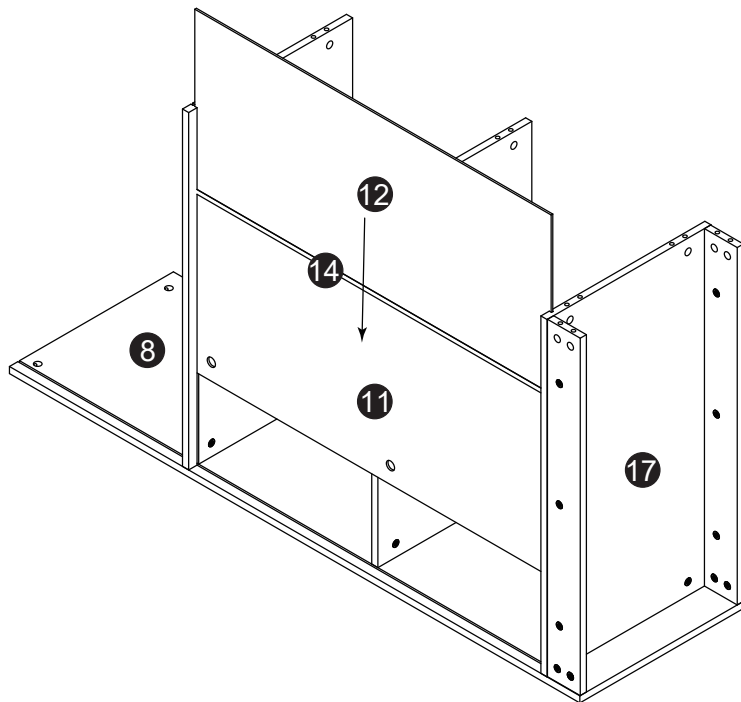

# STEP

05



06

- Ax10 
- Cx6 

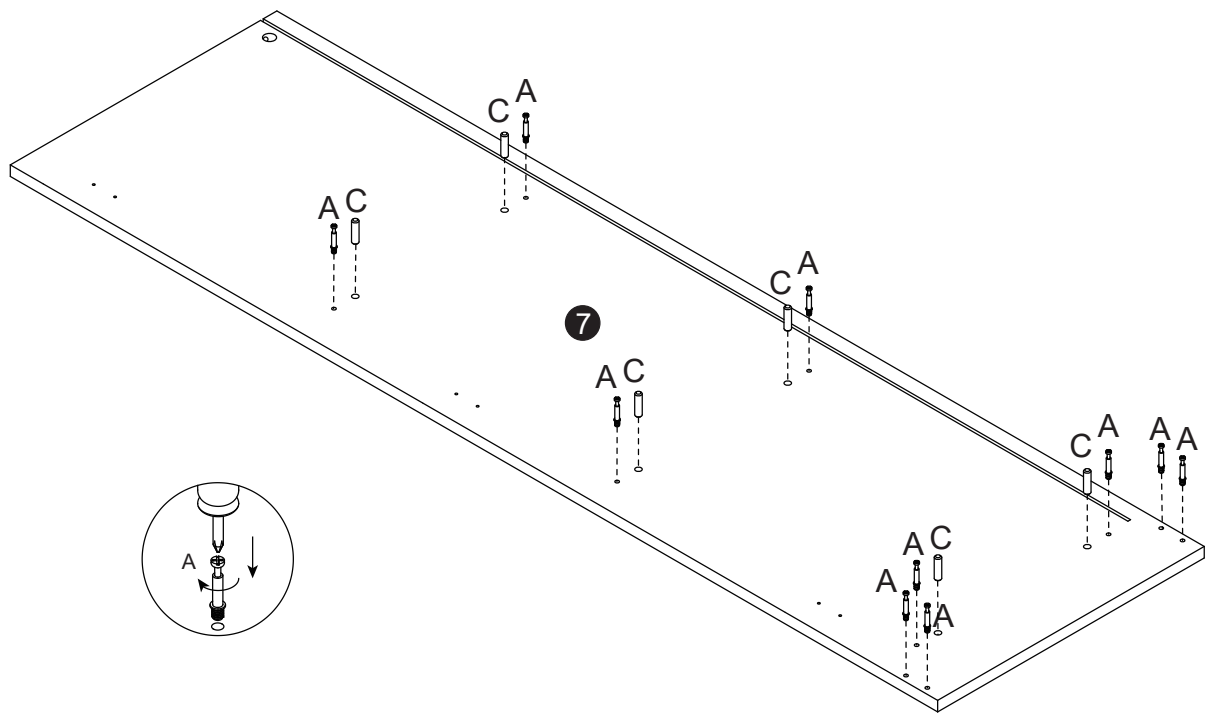

07

Bx10 

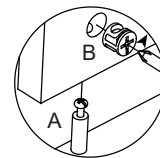
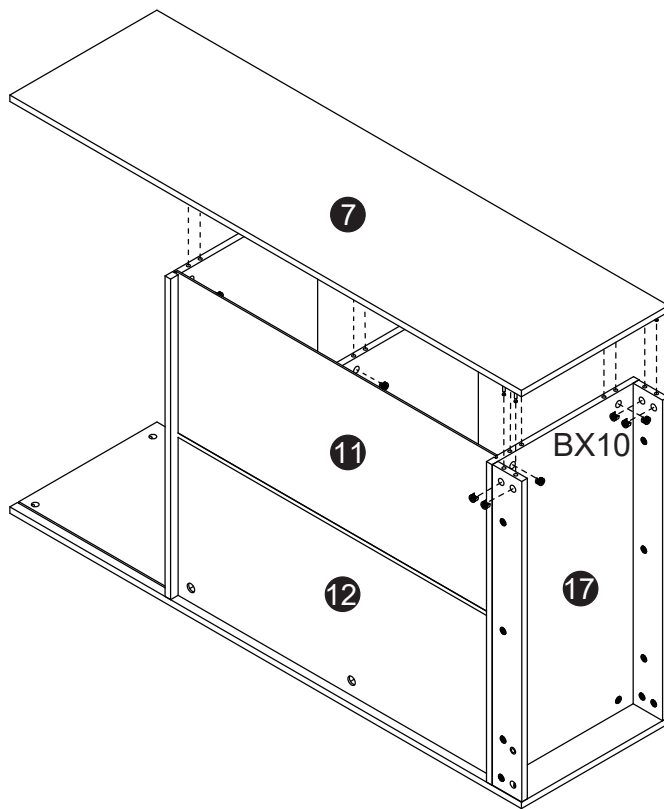

08

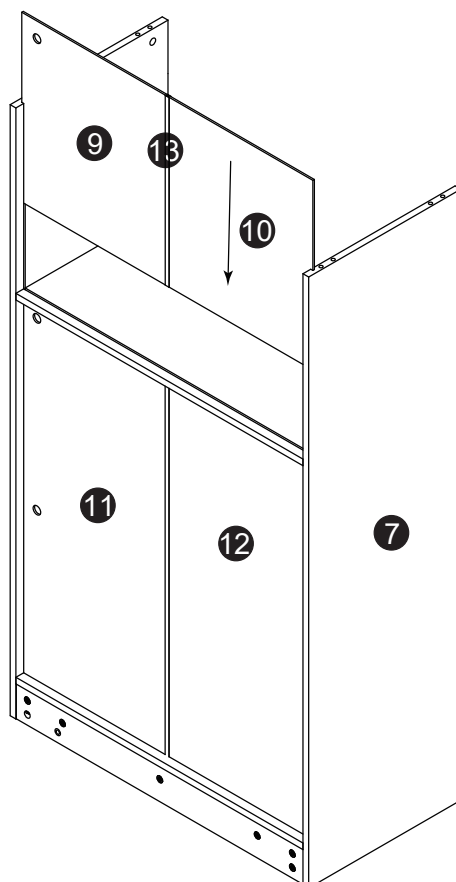

09

Ax4



Cx4

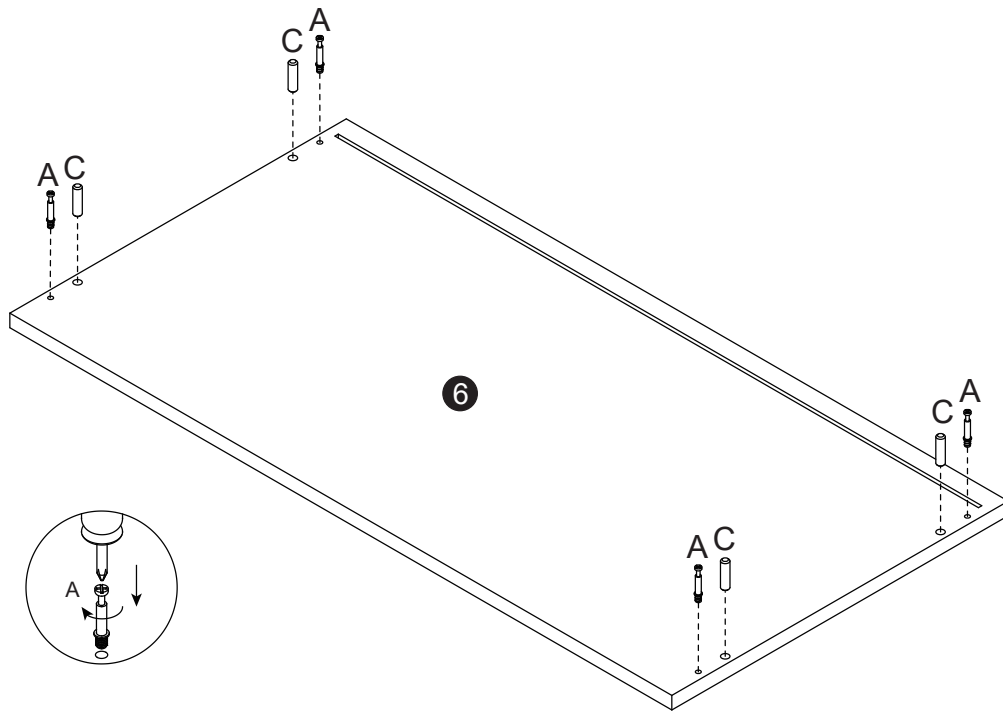

10

Bx4

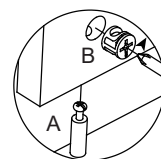
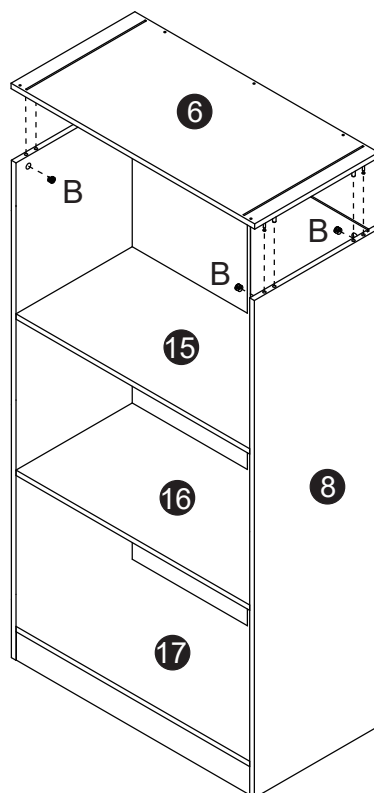



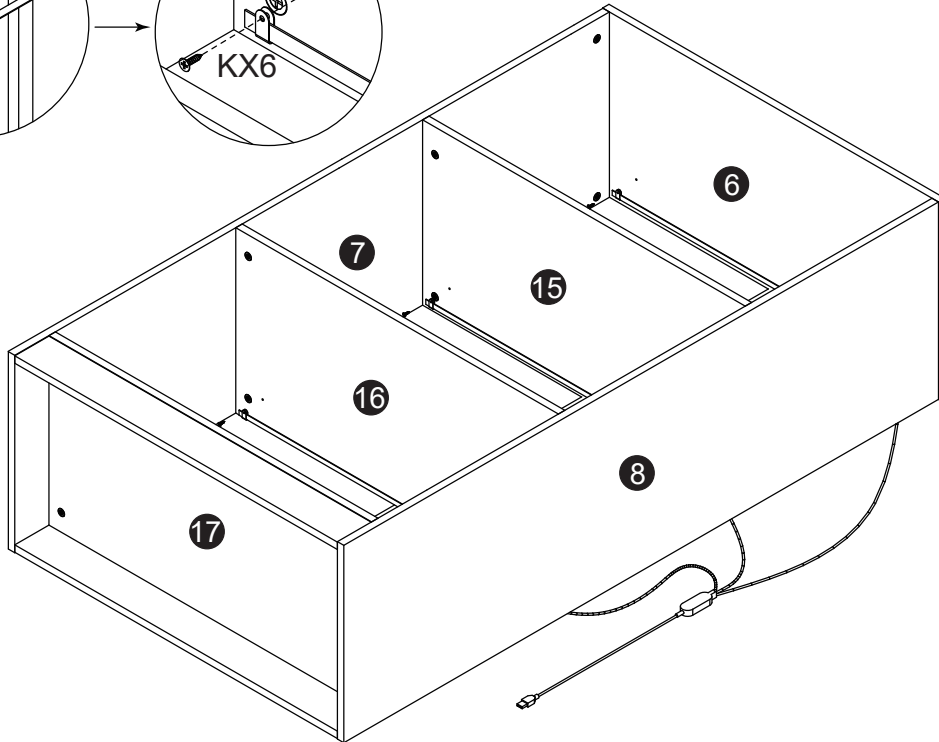
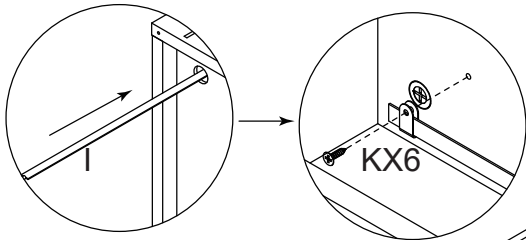

# STEP

11

- Ix1 
- Kx6 



12

- Ex4 
- Hx2 
- Gx6 
- Dx12 

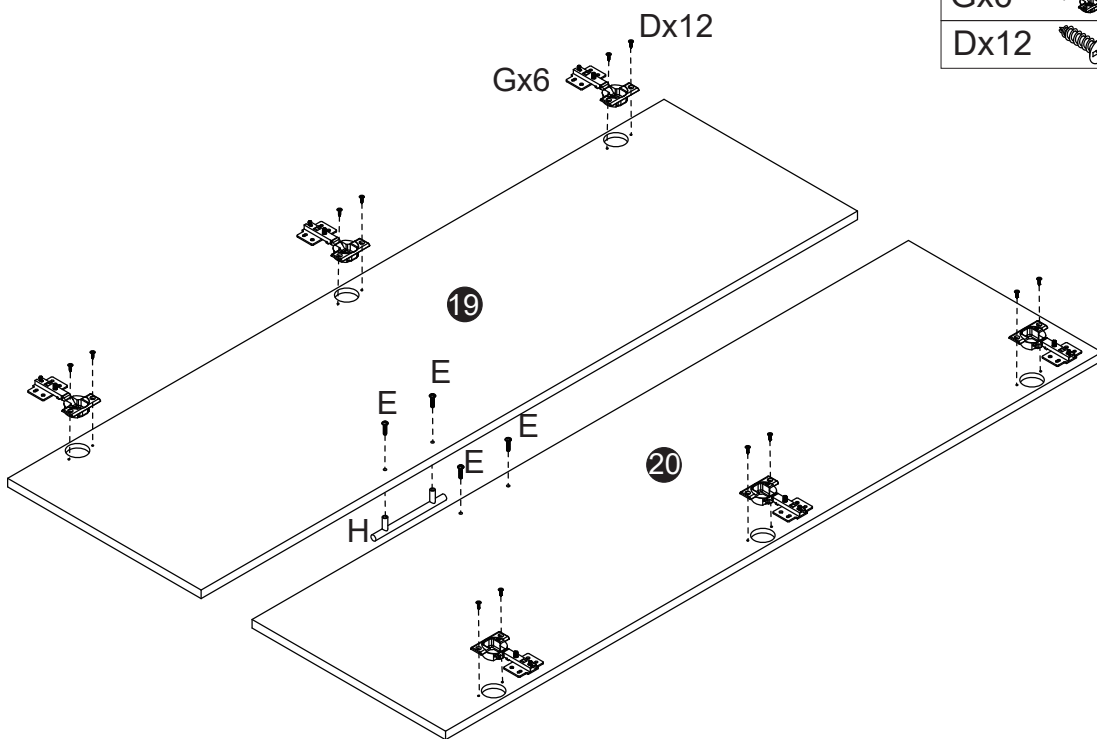

# STEP

13

Dx24

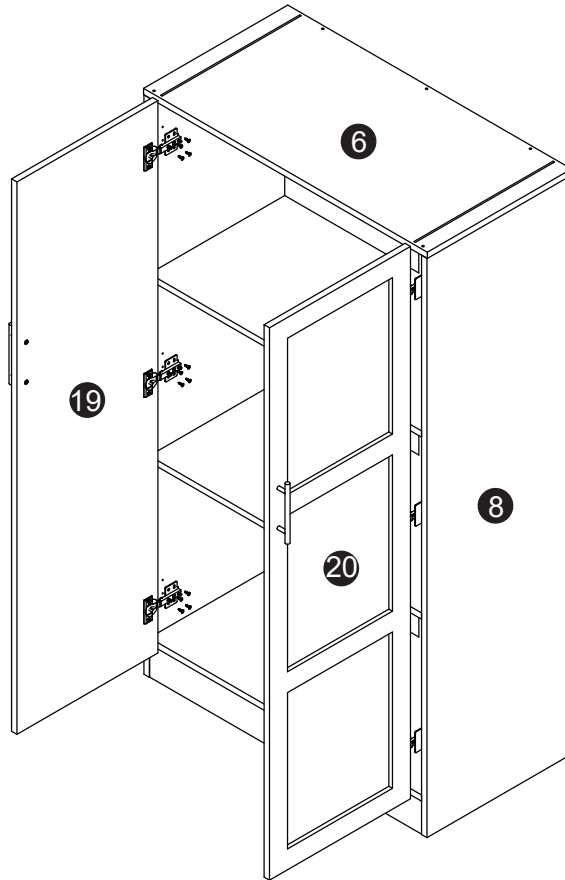
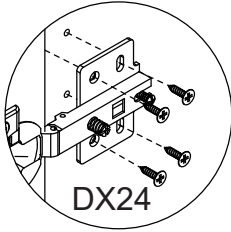

14

Ax5

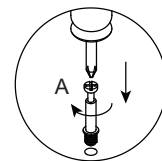
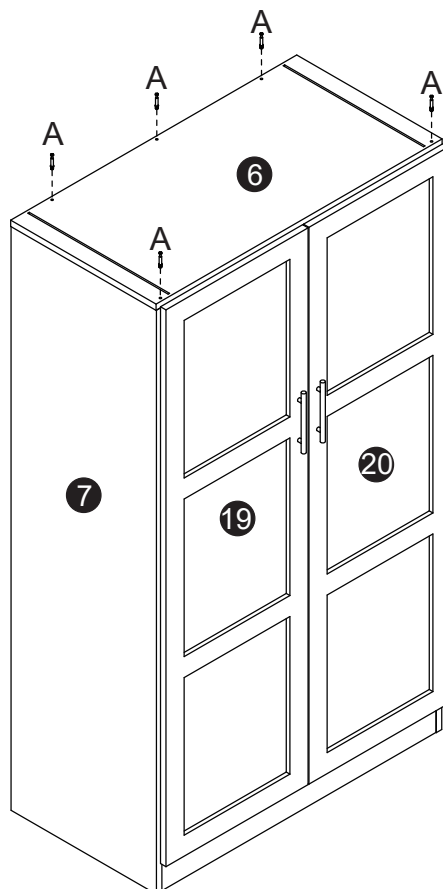

15

Ax12 

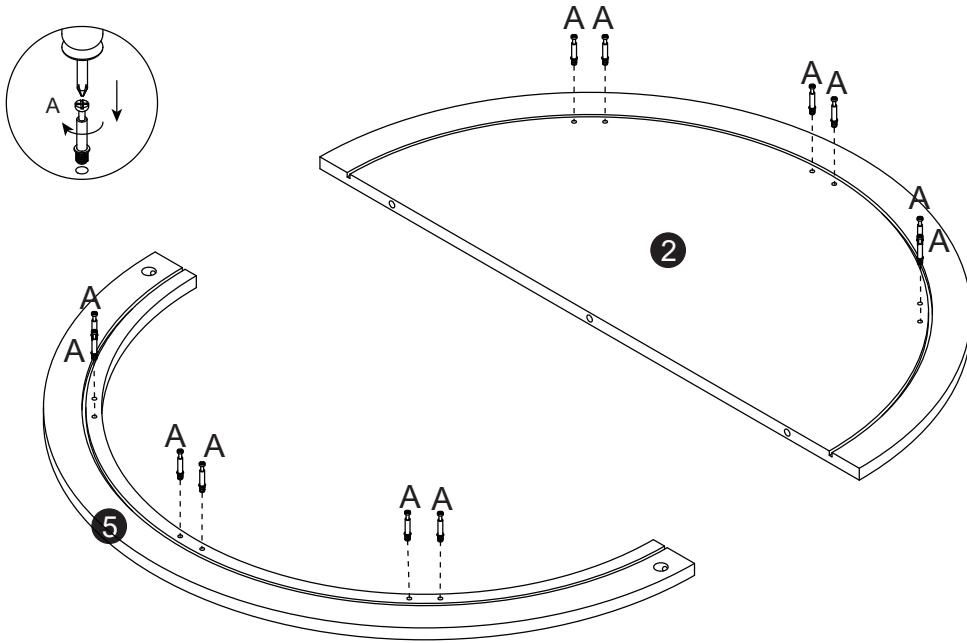

16

Bx6 

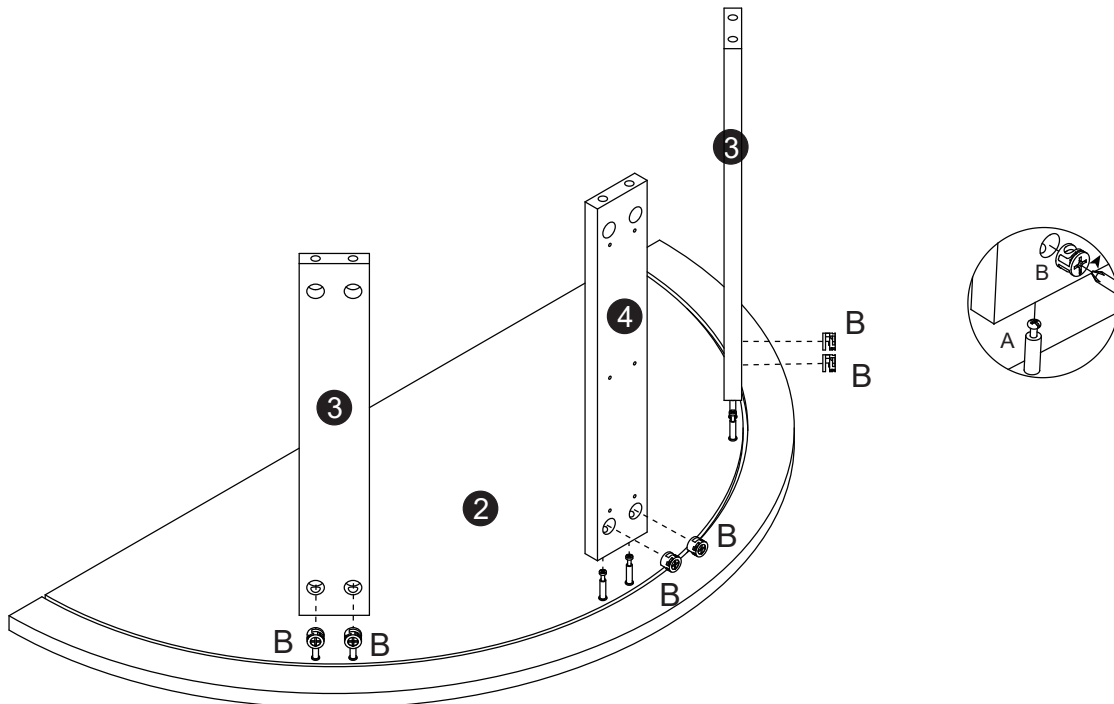

17

Bx6

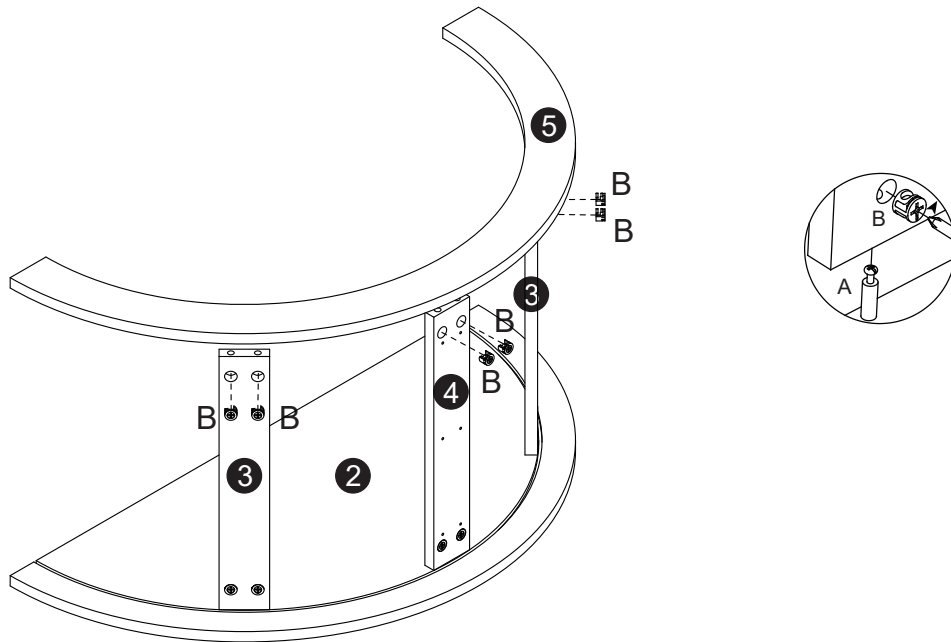

18

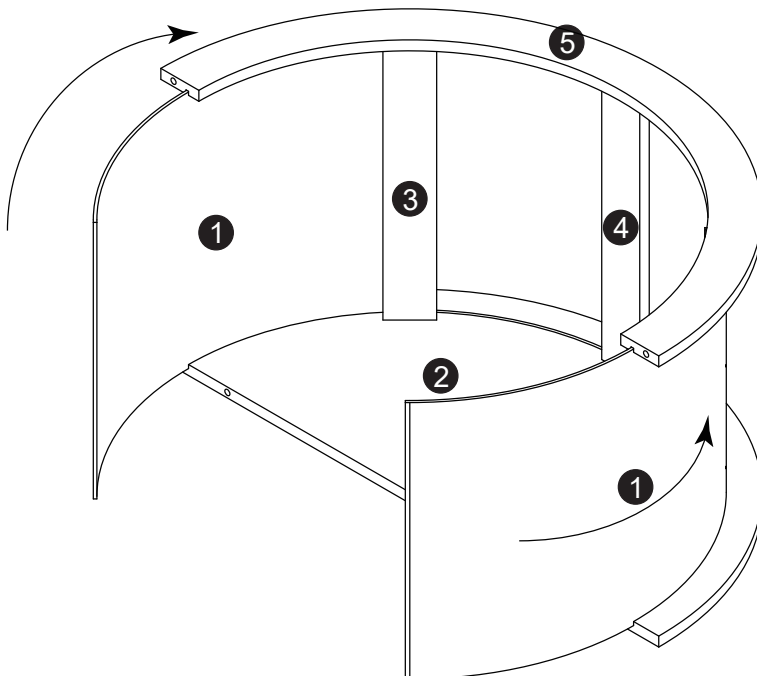

19

Dx6

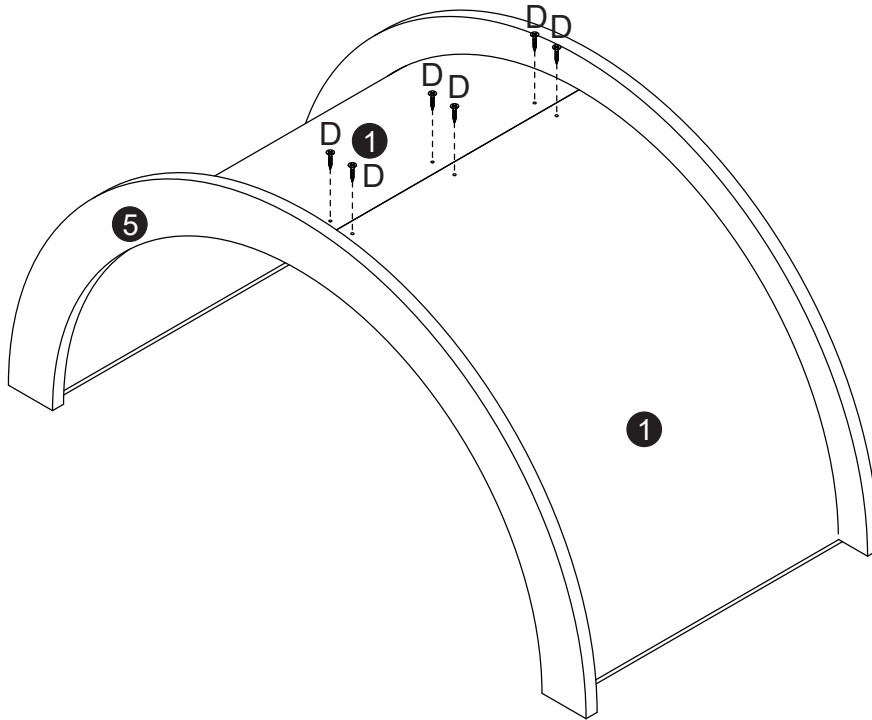



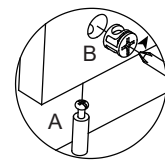
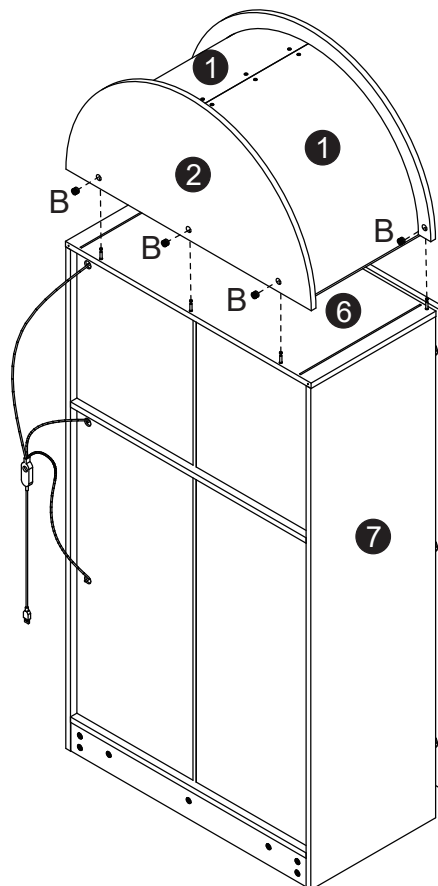

20

Bx5



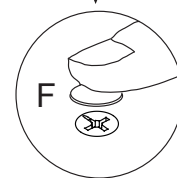
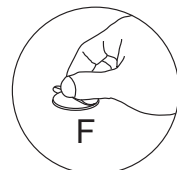
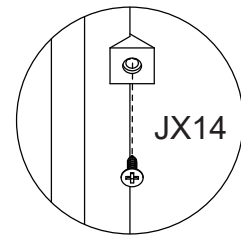
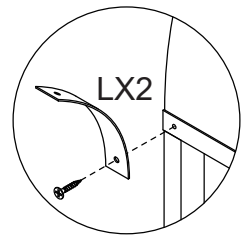
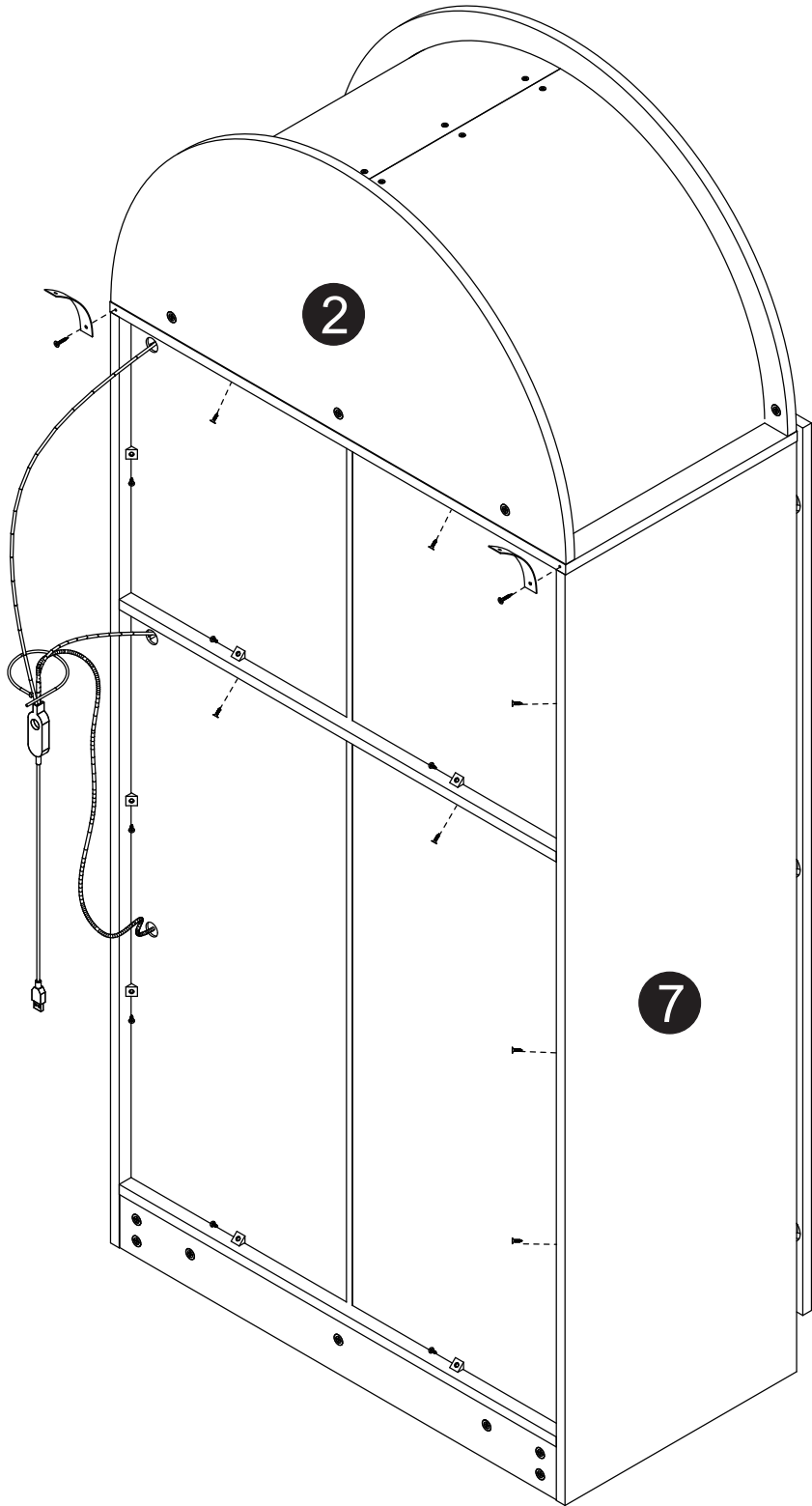

21

Jx14	
Lx2	
Fx47	
Px1	



22

Mx2 

Nx2 

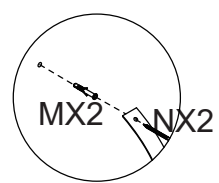
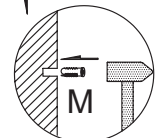
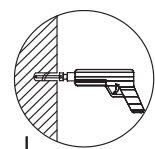
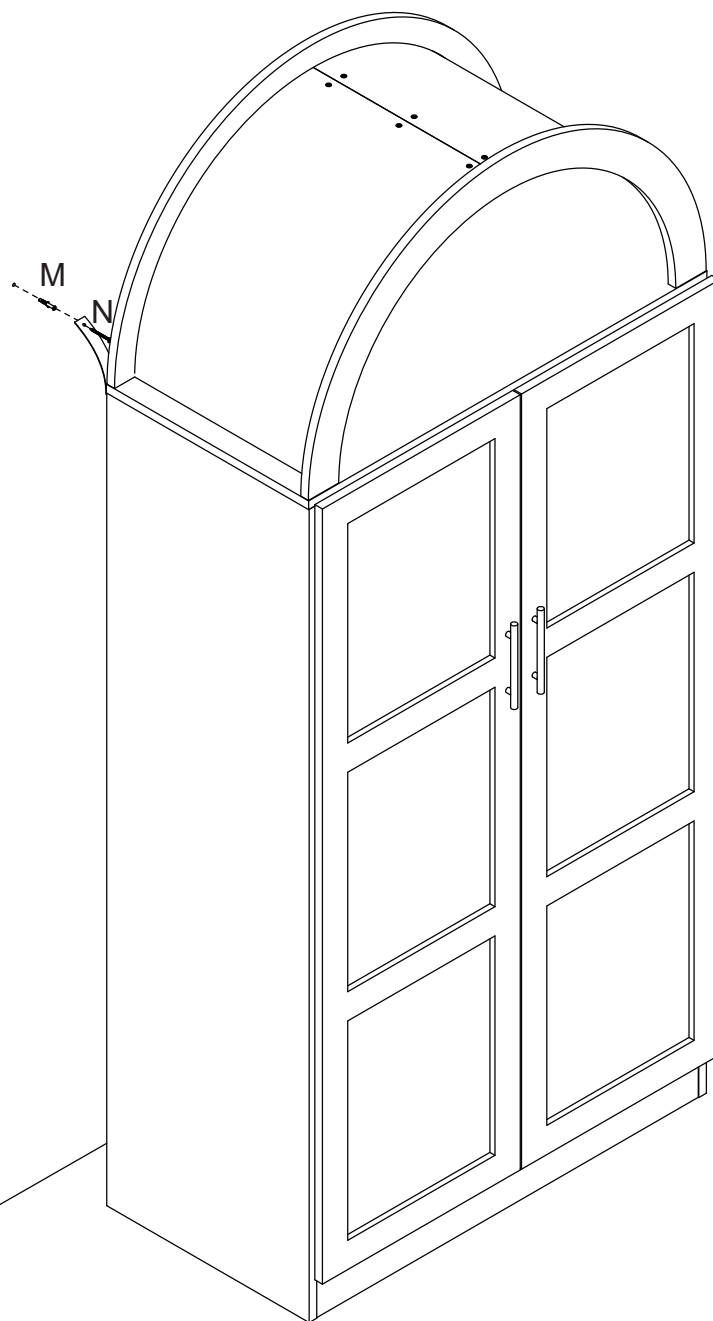

# AFTER-SALE SERVICE

If you have any suggestions for our products or notice any quality issues, please contact us first. Our after-sales team will respond within 24 hours and will do everything possible to provide you with a satisfactory solution.

## Guaranteed Customer Service

Your shopping experience is very important to us!

Feel unsatisfied? **Contact us!**

Have any questions? **Contact us!**

Wanna Share how wonderful our smart products make your home?

Share your pictures with us.

Any suggestions? **Contact us!**

We will check and give feedback.