

Assembly | Asambla | Assemblage

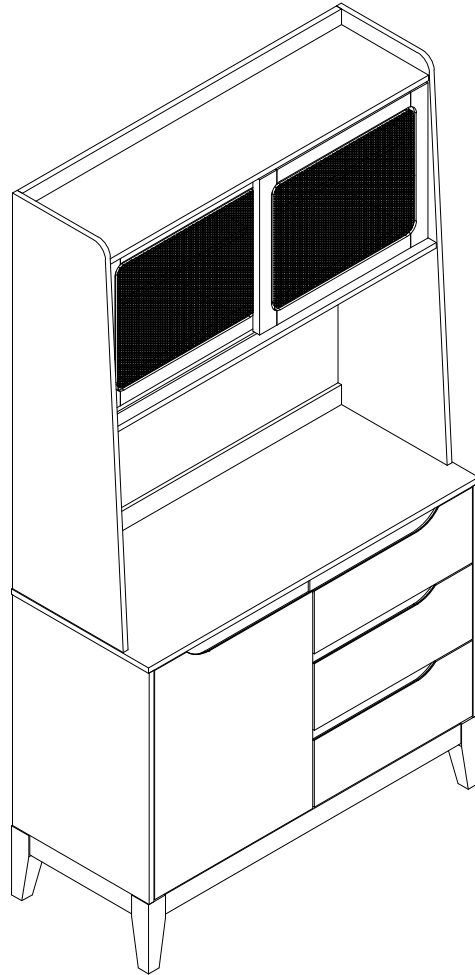

Assembly | Asambllea | Assemblage

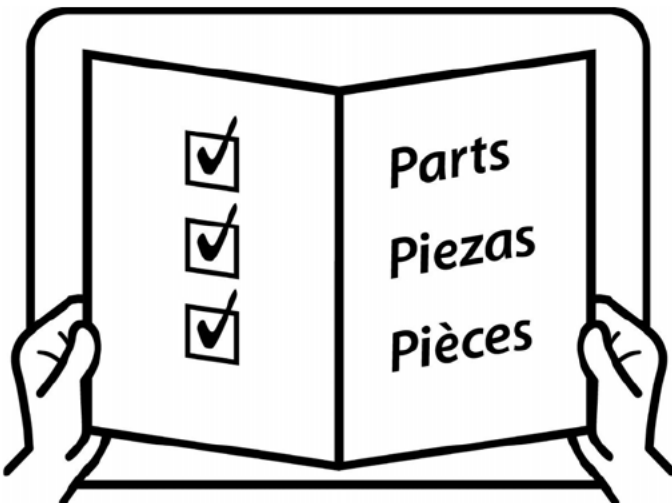
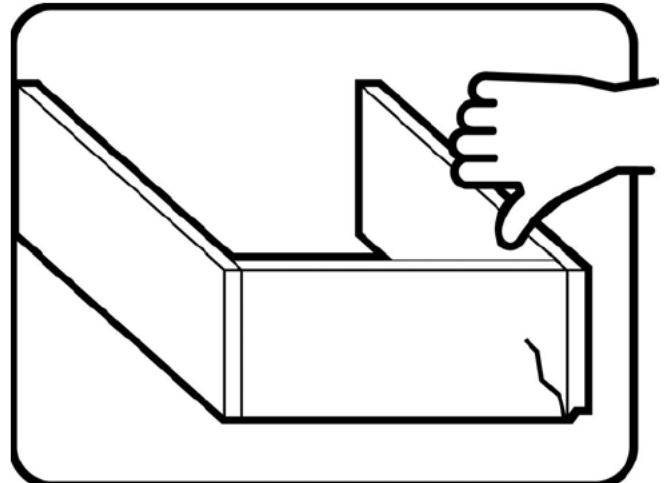
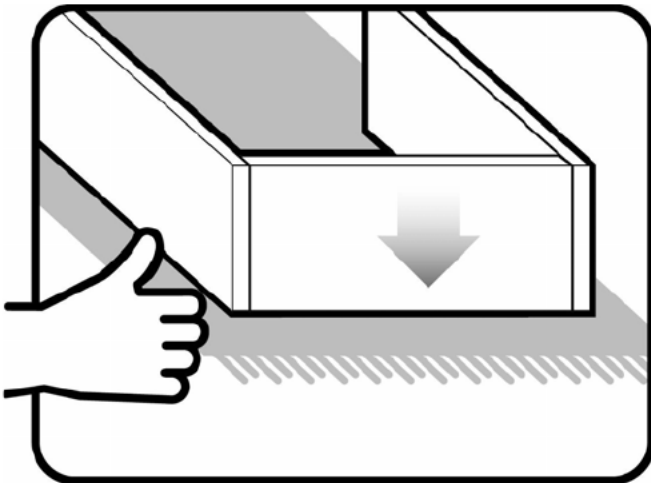
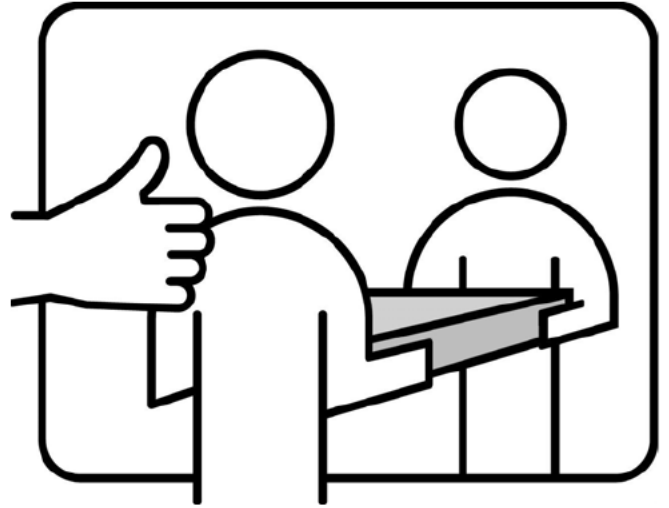
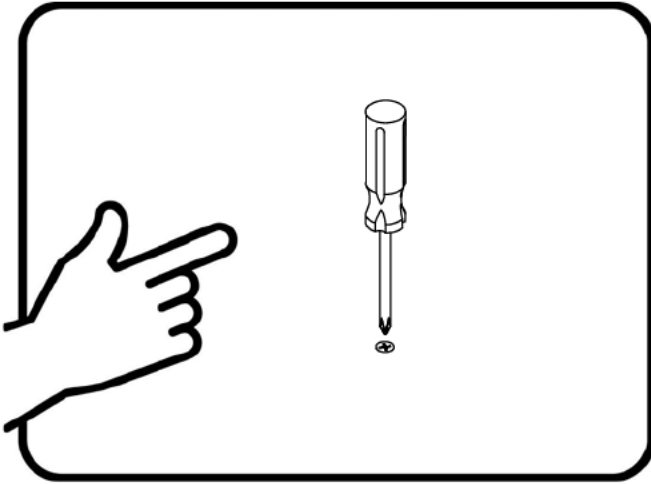

Assembly | Asamblea | Assemblage

Techniques | Técnicas | Techniques

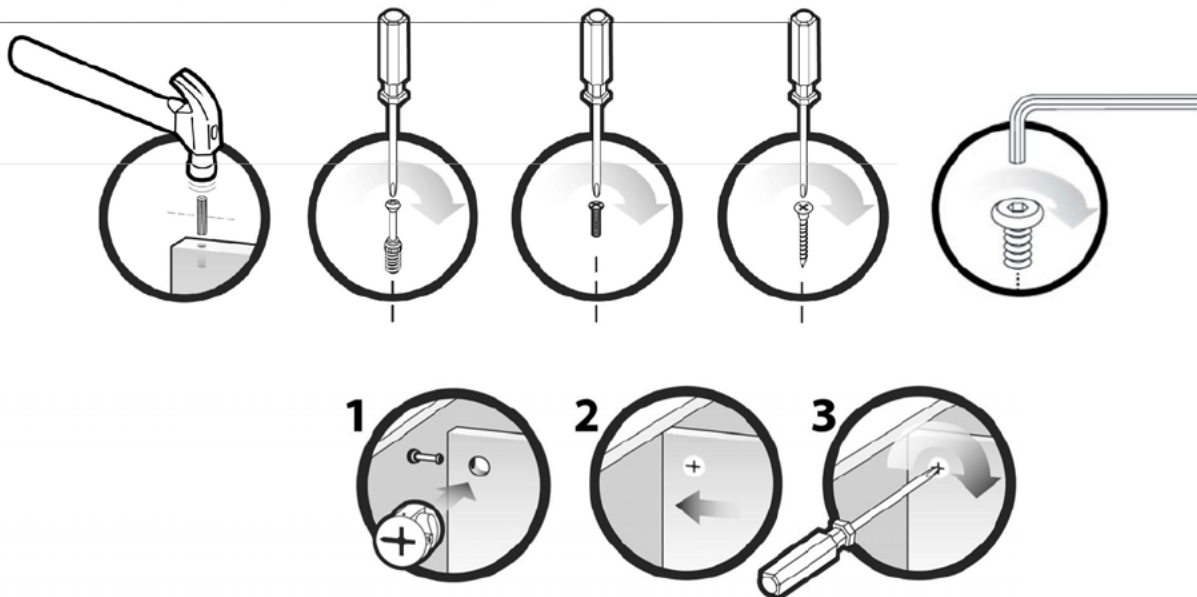

Care | Cuidado | Entretien







Safety | Seguridad | Sécurité



Note! | ¡Nota! | Remarque!

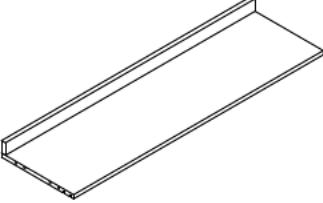
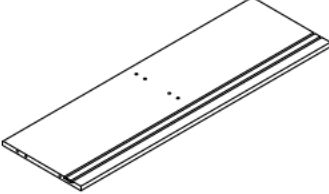

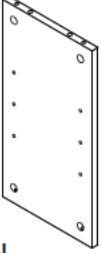
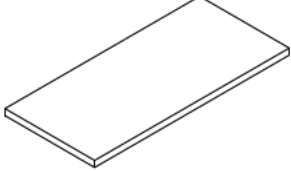
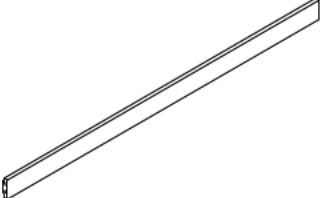
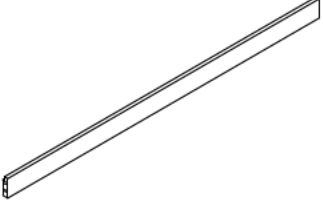
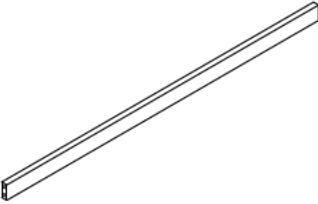
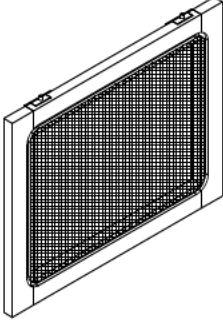

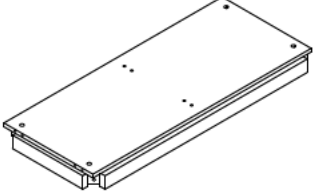
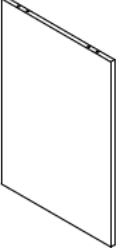
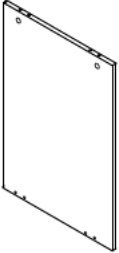
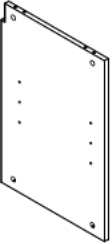
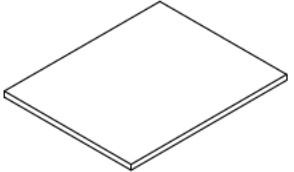



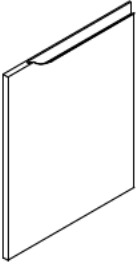
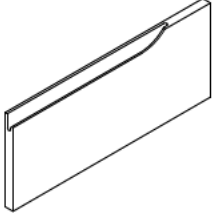
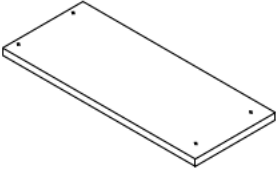
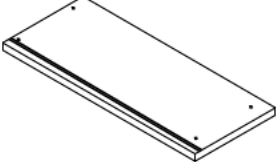
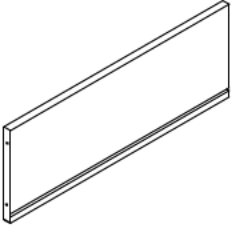
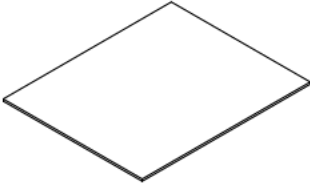
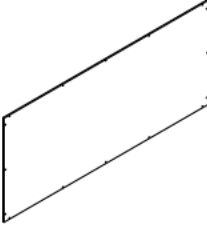
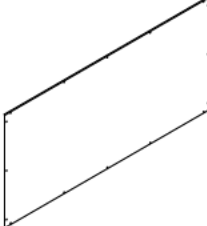
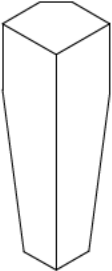
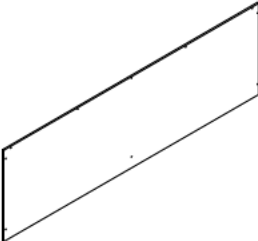
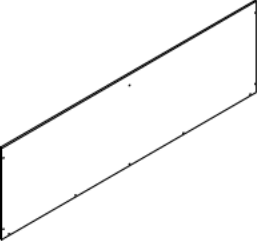

Assembly | Asambla | Assemblage

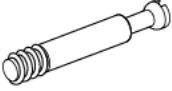
<p>A x1</p>  <p>Top panel Panel superior Panneau supérieur</p>	<p>B x1</p>  <p>Bottom panel Panel inferior Panneau du bas</p>	<p>C x1</p>  <p>Upper left side panel Panel lateral superior izquierdo Panneau latéral supérieur gauche</p>	<p>D x1</p>  <p>Upper right side panel Panel lateral superior derecho Panneau latéral supérieur droit</p>
<p>E x1</p>  <p>Middle panel Panel medio Panneau du milieu</p>	<p>F x2</p>  <p>Upper shelf panel Panel de estante superior Panneau d'étagère supérieur</p>	<p>G x1</p>  <p>Upper rail Carril superior Rail supérieur</p>	<p>H x1</p>  <p>Middle rail Carril medio Rail intermédiaire</p>
<p>I x1</p>  <p>Lower rail Riel inferior Rail inférieur</p>	<p>J x2</p>  <p>Door panel Panle de la puerta Panneau de porte</p>	<p>K x1</p>  <p>Lower panel Panle inferior Panneau inférieur</p>	<p>L x1</p>  <p>Base Base Base</p>
<p>M x1</p>  <p>Lower left side panel Panel lateral inferior izquierdo Panneau latéral inférieur gauche</p>	<p>N x1</p>  <p>Lower right side panel Panel lateral inferior derecho Panneau latéral inférieur droit</p>	<p>O x1</p>  <p>Lower middle panel Panel medio inferior Panneau central inférieur</p>	<p>P x1</p>  <p>Lower shelf panel Panel de estante inferior Panneau d'étagère inférieur</p>

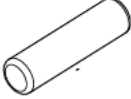
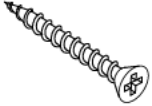
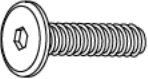

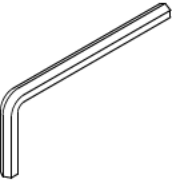

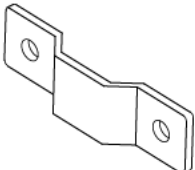
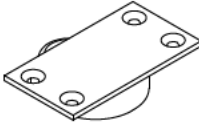
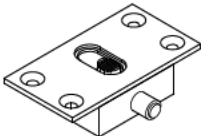
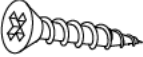
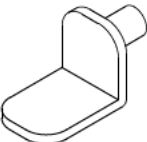
Assembly | Asambla | Assemblage

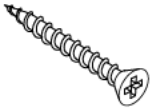
<p>Q x1</p>  <p>Lower door panel Panel de puerta inferior Panneau de porte inférieur</p>	<p>R x3</p>  <p>Drawer front panel Panel frontal del cajón Panneau avant du tiroir</p>	<p>S x3</p>  <p>Drawer back panel Panel trasero del cajón Panneau arrière du tiroir</p>	<p>TL x3</p>  <p>Drawer left side panel Panel lateral izquierdo del cajón Panneau latéral gauche du tiroir</p>
<p>TR x3</p>  <p>Drawer right side panel Panel lateral derecho del cajón Panneau latéral droit du tiroir</p>	<p>U x3</p>  <p>Drawer bottom panel Panel inferior del cajón Panneau inférieur du tiroir</p>	<p>V x1</p>  <p>Top upper back panel Panel trasero superior superior Panneau arrière supérieur supérieur</p>	<p>W x1</p>  <p>Top lower back panel Panel trasero inferior superior Panneau arrière inférieur supérieur</p>
<p>X x4</p>  <p>Leg Pierna Jambe</p>	<p>Y x1</p>  <p>Bottom lower back panel Panel trasero inferior inferior Panneau inférieur inférieur du dos</p>	<p>Z x1</p>  <p>Bottom upper back panel Panel trasero superior inferior Panneau arrière supérieur inférieur</p>	

Assembly | Asamlea | Assemblage

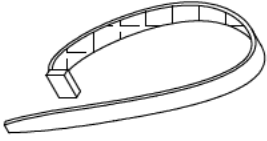
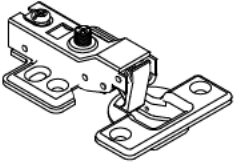
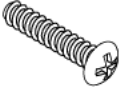
<p>1 x34</p>  <p>Cam Bolt Perno de leva Boulon à came</p>	<p>2 x34</p>  <p>Cam lock Bloqueo de la leva Serrure à came</p>	<p>3 x36</p>  <p>Wood Dowel Taco de madera Cheville en bois Ø1/4"x1"L</p>	<p>4 x24</p>  <p>Screws Tornillo Vis Ø1/4" *1"L</p>
<p>5 x8</p>  <p>Bolts Tornillo Boulon Ø1/4"*2"L</p>	<p>6 x8</p>  <p>Spring washer Arandela de resorte Rondelle élastique</p>	<p>7 x8</p>  <p>Flat washer Arandela plana Rondelle plate</p>	<p>8 x1</p>  <p>Allen wrench Llava Allen Clé Allen</p>
<p>9 x54</p>  <p>Screws Tornillo Vis Ø1/4" *1/2"L</p>	<p>10 x4</p>  <p>Hook Soporte Support</p>	<p>11 x4</p>  <p>Door roller Rodillo de la puerta Rouleau de porte</p>	<p>12 x4</p>  <p>Door pin Perno de la puerta Goupille de porte</p>
<p>13 x32</p>  <p>Screws Tornillo Vis Ø1/4"*1/2"L</p>	<p>14 x12</p>  <p>Shelf pin Estante pin Goupille d'étagère</p>	<p>15 x4</p>  <p>Anchor Ancla Ancre</p>	<p>16 x4</p>  <p>Screws Tornillo Vis Ø5/16" *1-1/2"L</p>

Assembly | Asamlea | Assemblage

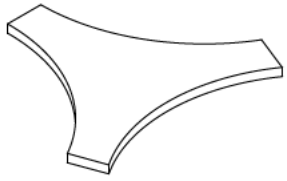
<p>17 x2</p>  <p>Tie Lazo L'attache</p>	<p>18 x2</p>  <p>Hinges Bisagra Charnière</p>	<p>19 x2</p>  <p>Bolts Tornillo Boulon</p> <p>Ø5/32* 5/8"L</p>	<p>20 x34</p>  <p>Cover Tapa Couverture</p>
<p>21 x12</p>  <p>Screws Tornillo Vis</p> <p>Ø1/4*5/8"L</p>	<p>22 x1</p>  <p>Towel bracket Soporte de toalla Support de serviette</p>	<p>23 x1</p>  <p>Cam tool Outil à came Herramienta de leva</p>	

Assembly | Asambla | Assemblage

STEP 1

4		x4
---	---	----

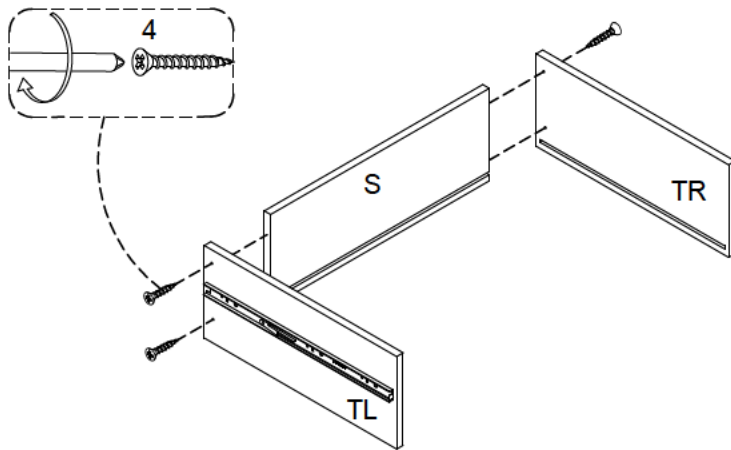

STEP 2

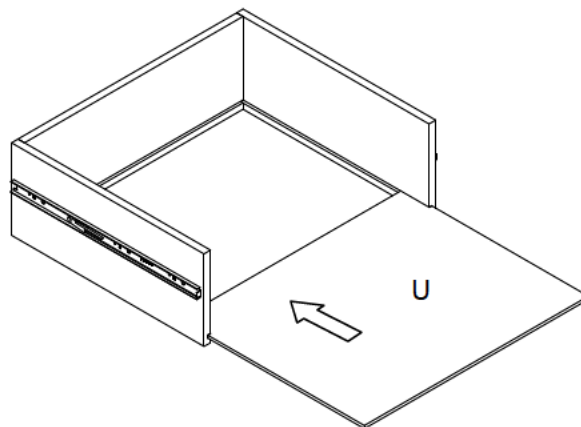



Assembly | Asambla | Assemblage

STEP 3

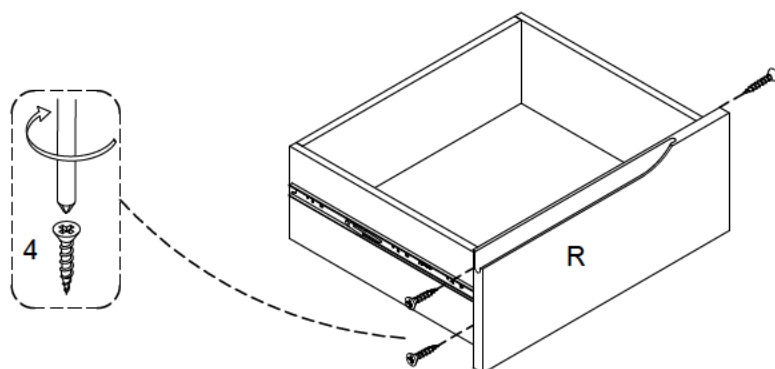
4		x4
---	---	----



STEP 4

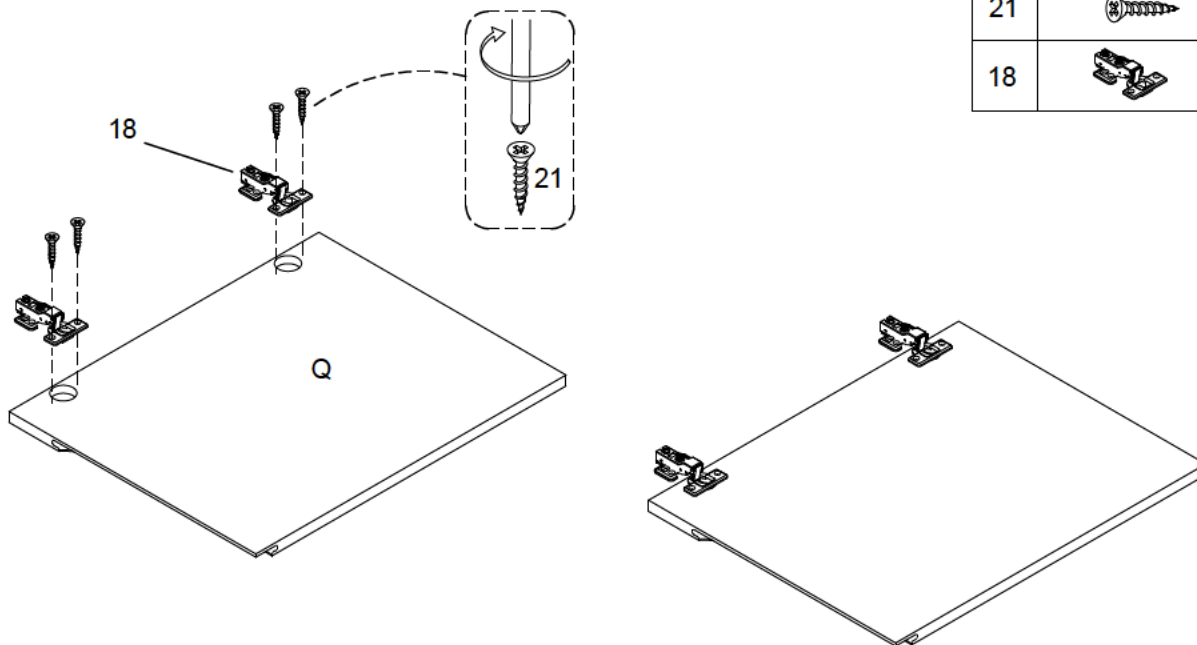

21		x4
18		x2



Assembly | Asambla | Assemblage

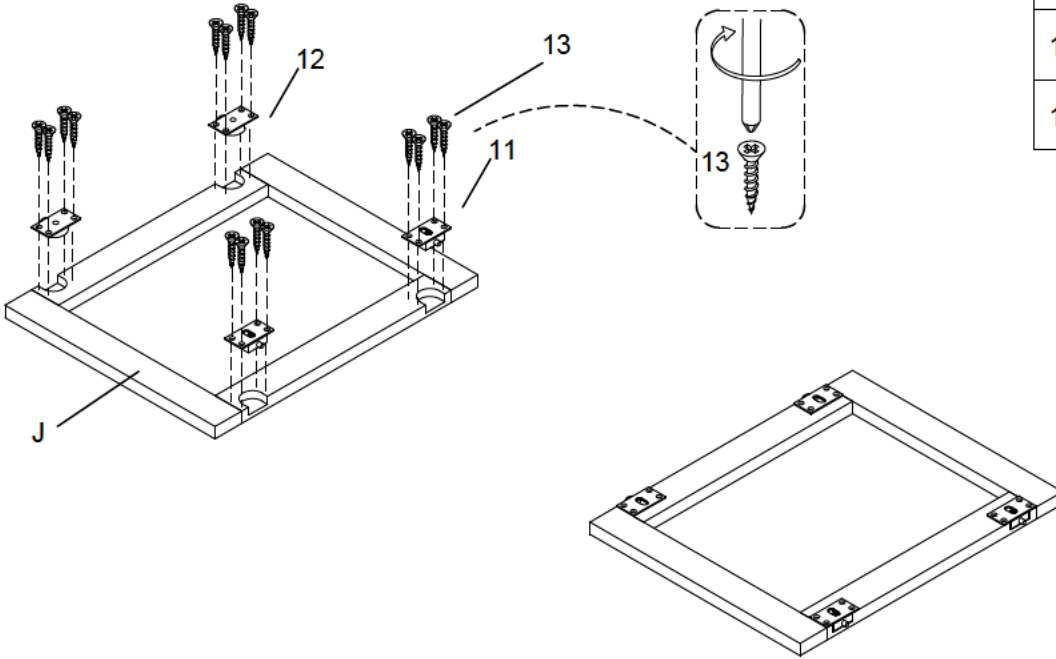

STEP 5

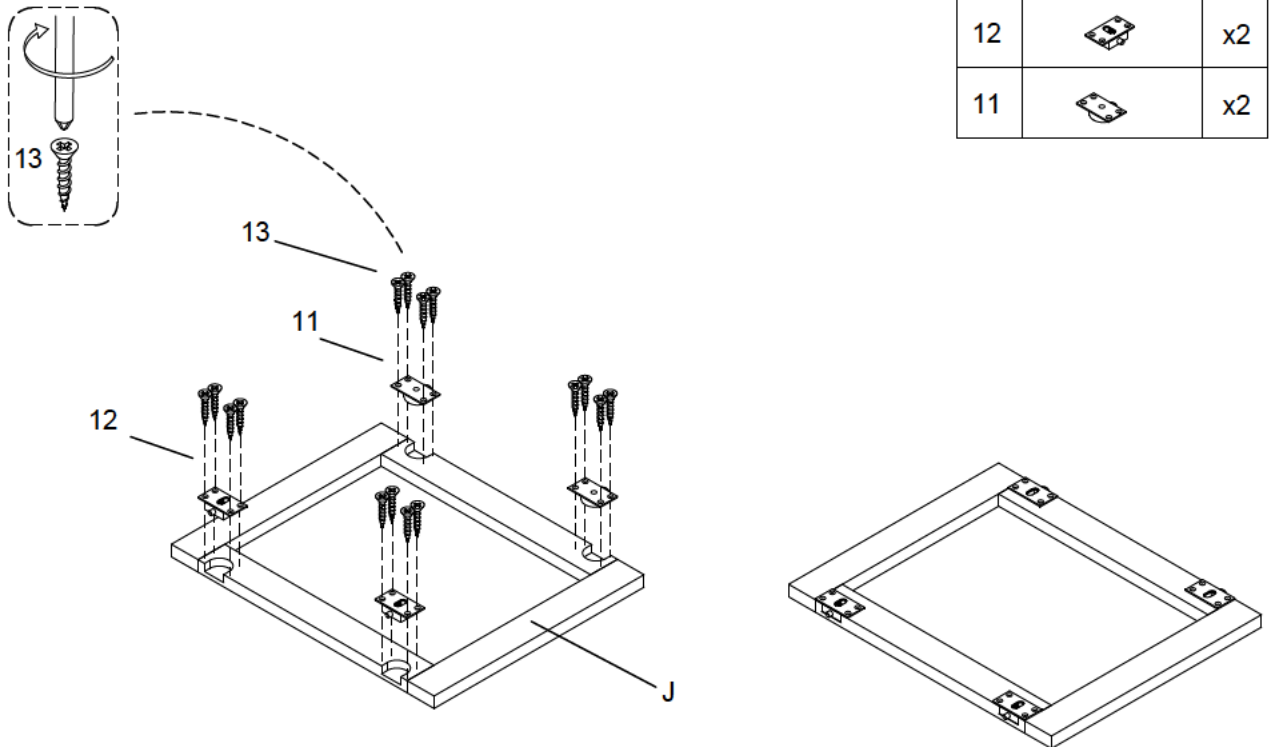

13		x16
12		x2
11		x2

STEP 6



13		x16
12		x2
11		x2

Assembly | Asambla | Assemblage

STEP 7

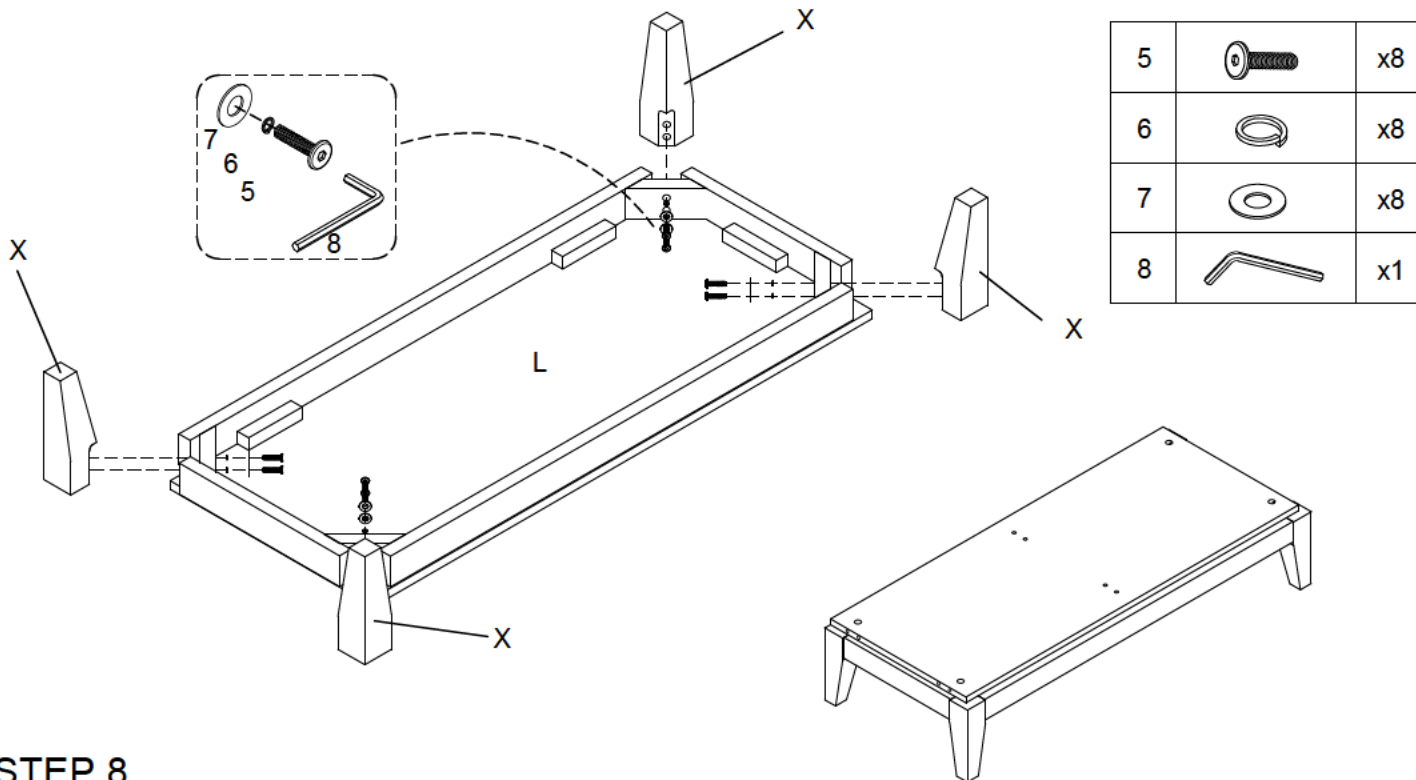

STEP 8

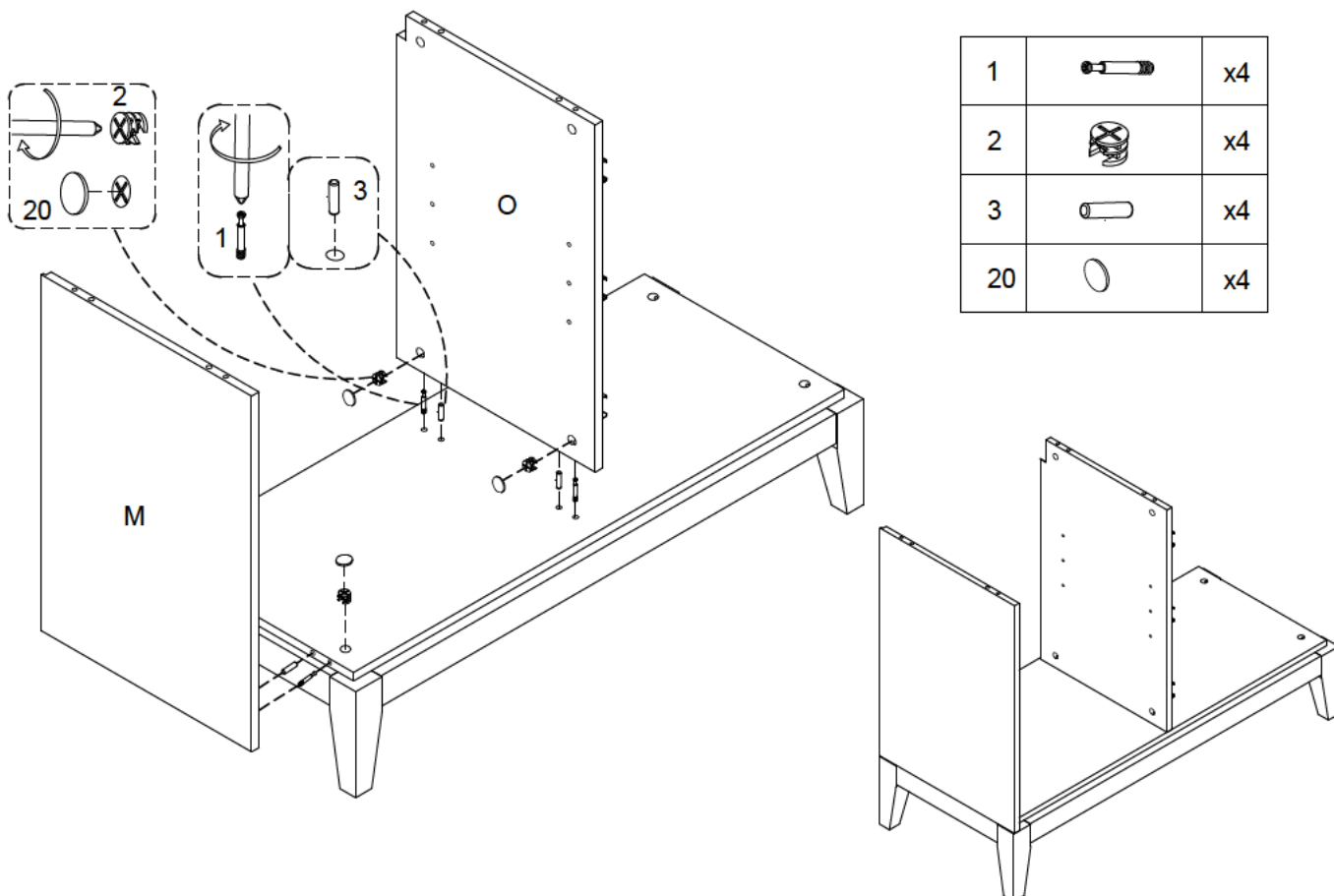

Assembly | Asambla | Assemblage

STEP 9

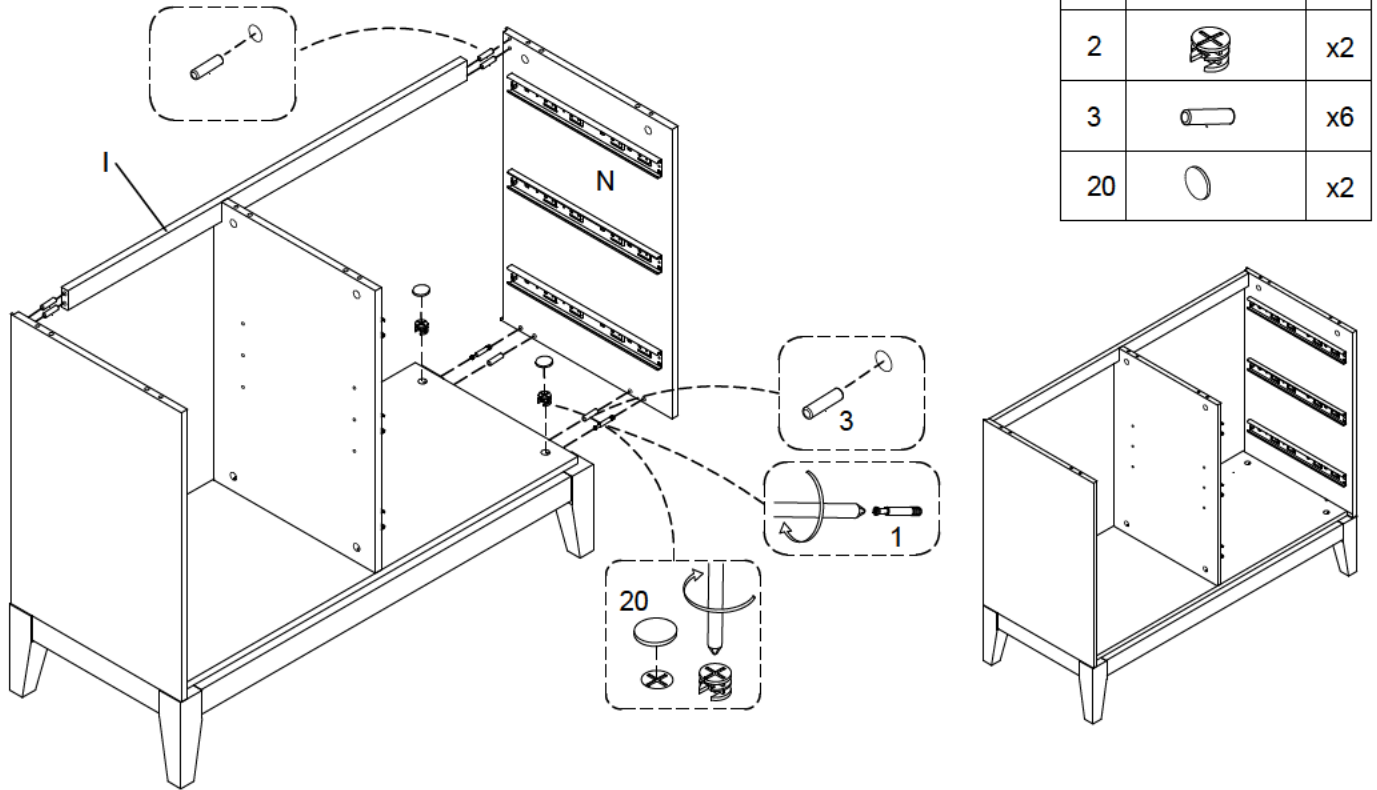

STEP 10

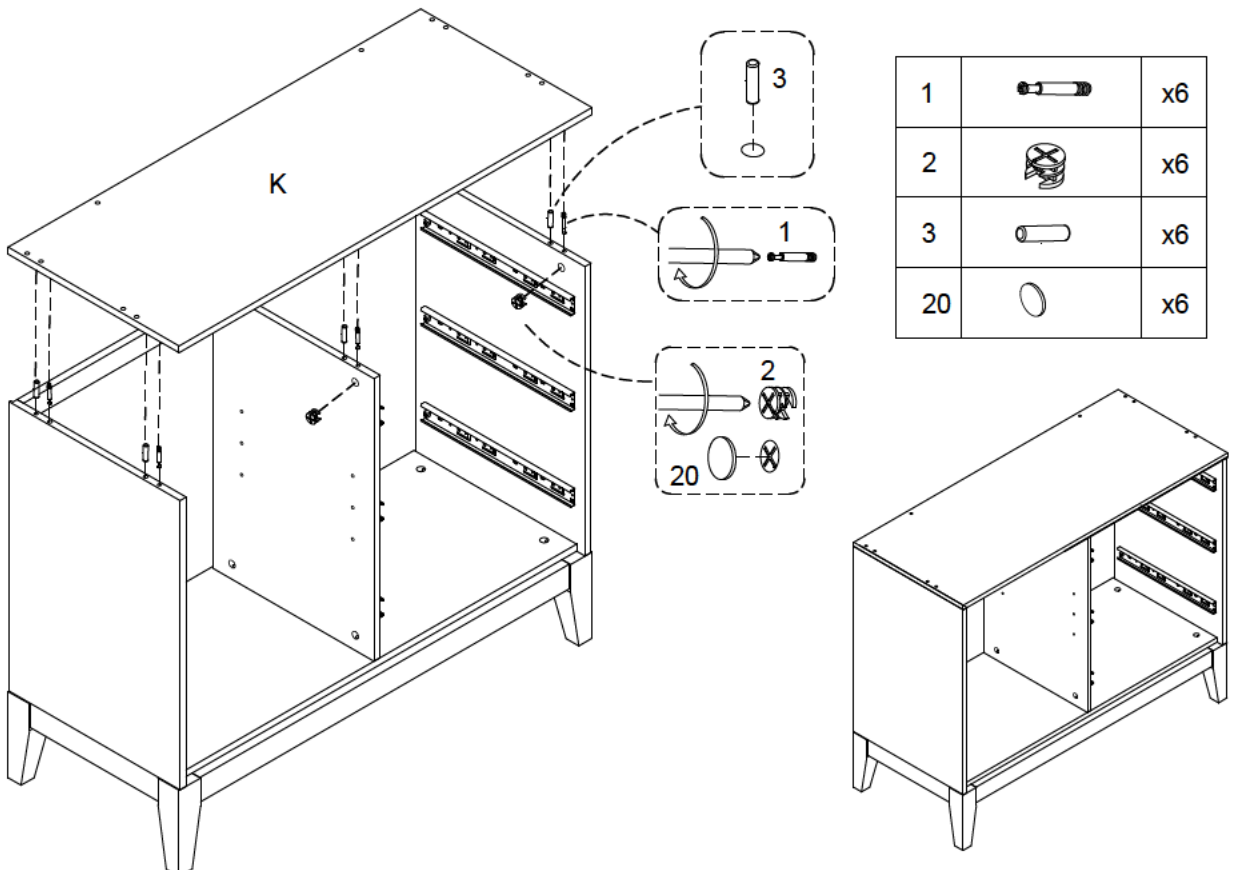

Assembly | Asambllea | Assemblage

Please move glider to the front end before inserting male glide



Assembly | Asambla | Assemblage

STEP 11

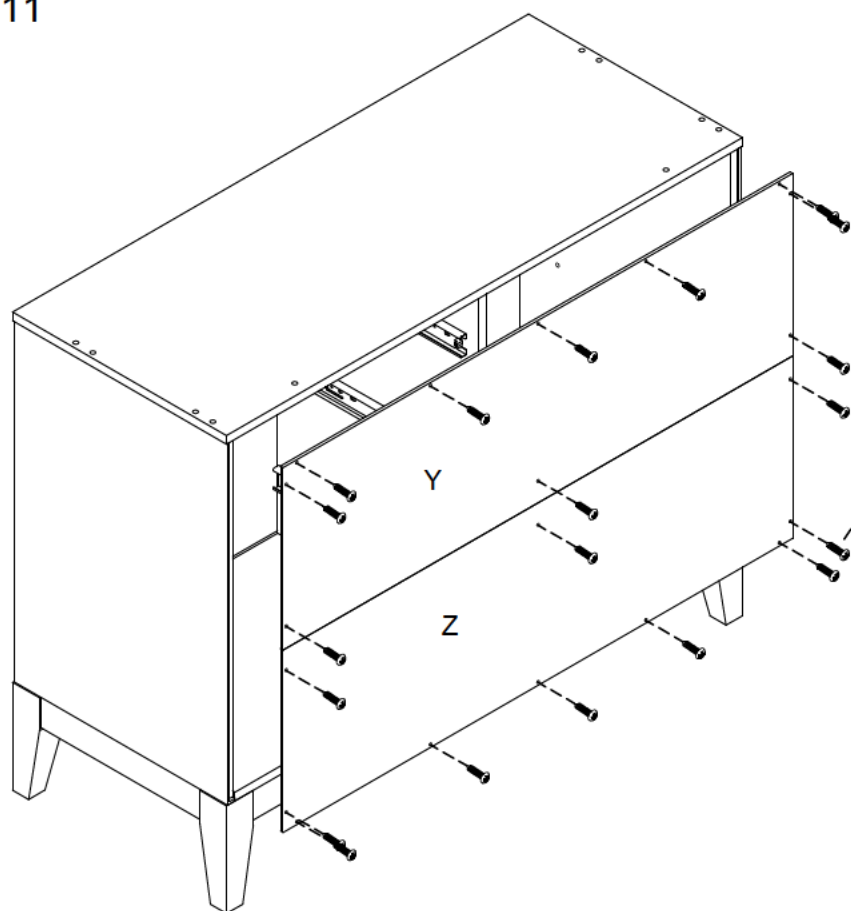

9		x20
---	---	-----

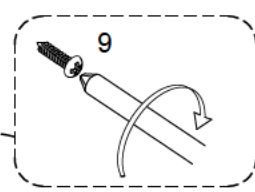

STEP 12

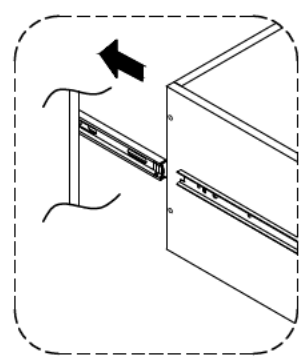
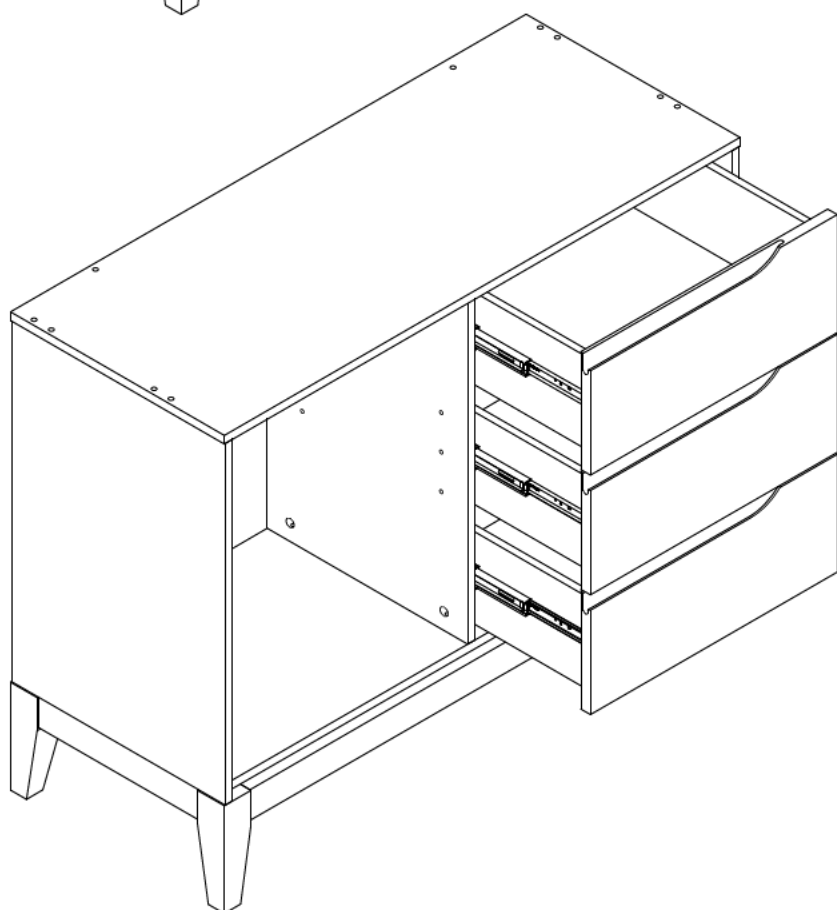

Assembly | Asamblea | Assemblage

STEP 13

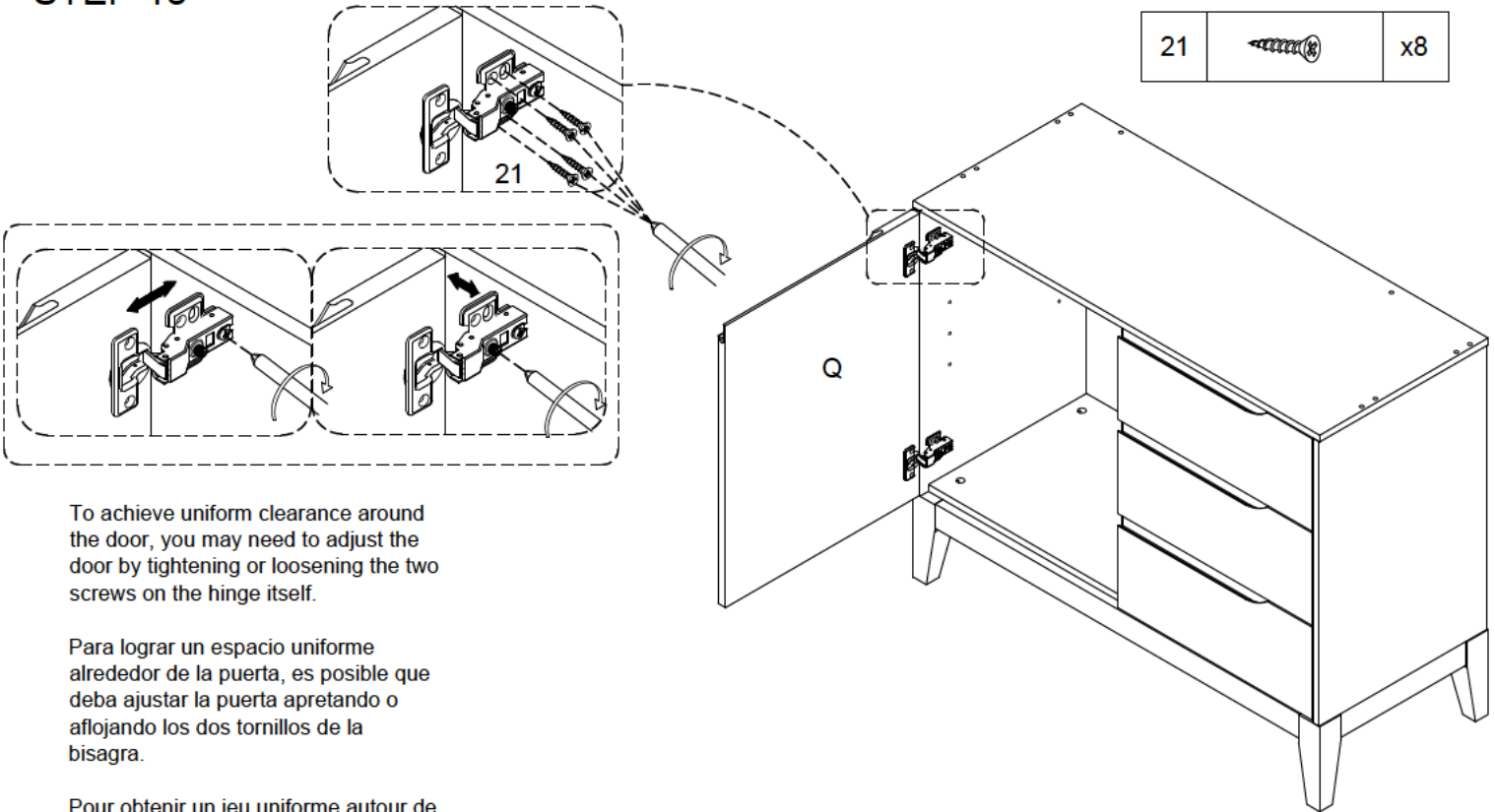

To achieve uniform clearance around the door, you may need to adjust the door by tightening or loosening the two screws on the hinge itself.

Para lograr un espacio uniforme alrededor de la puerta, es posible que deba ajustar la puerta apretando o aflojando los dos tornillos de la bisagra.

Pour obtenir un jeu uniforme autour de la porte, vous devrez peut-être ajuster la porte en serrant ou en desserrant les deux vis de la charnière.

STEP 14

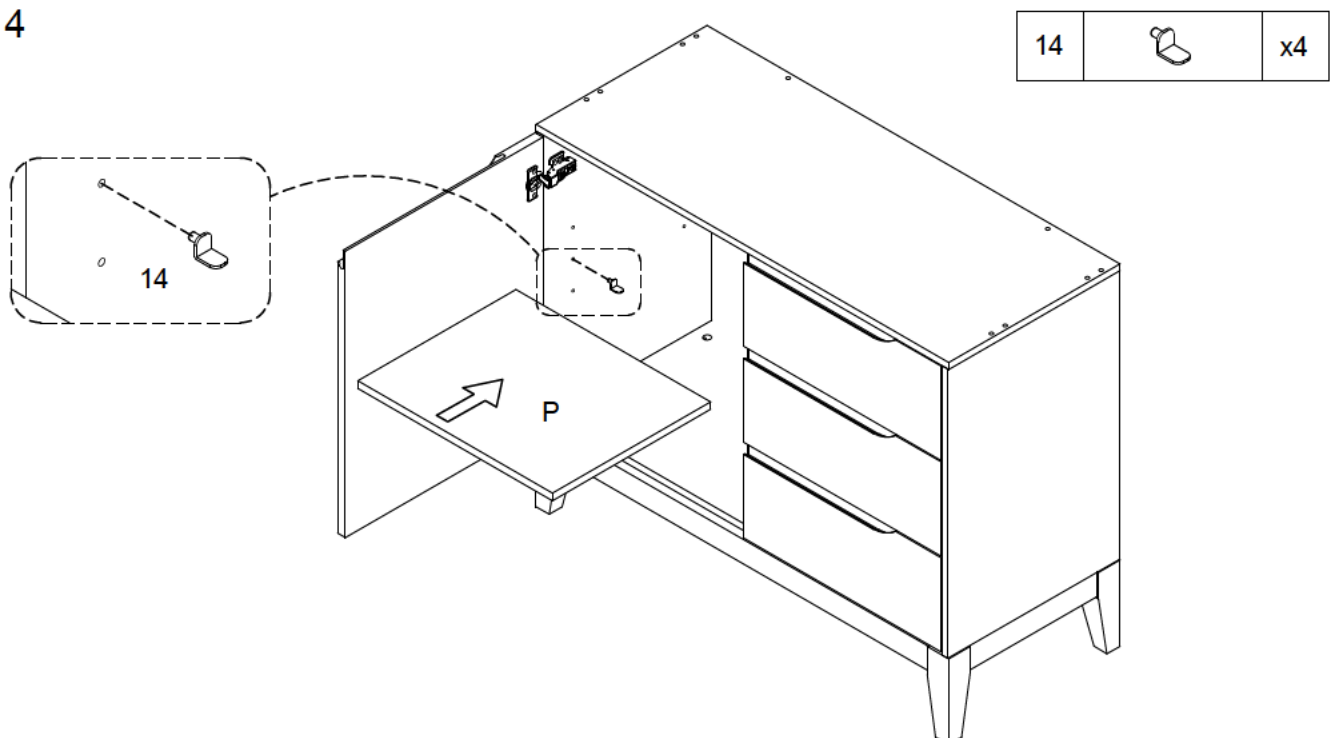

Assembly | Asambla | Assemblage

STEP 15

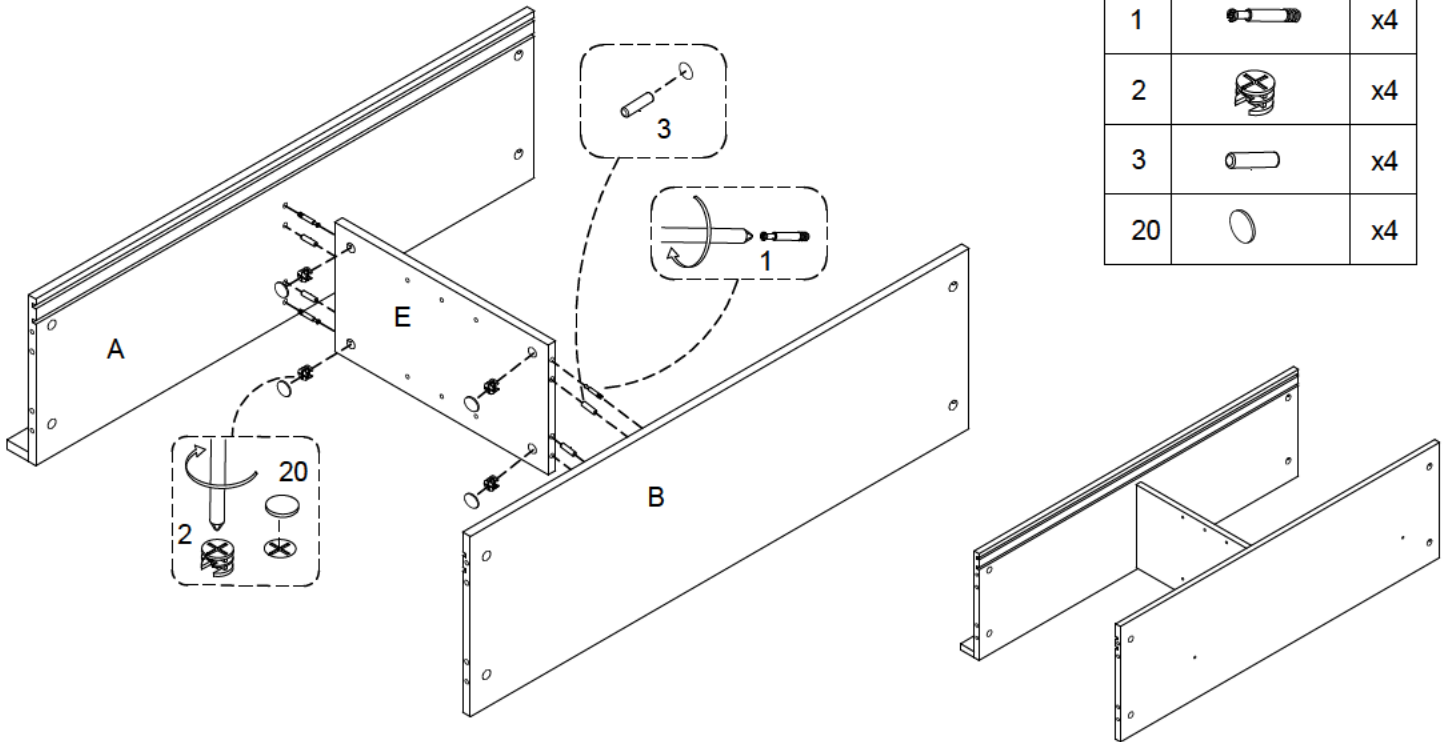

1		x4
2		x4
3		x4
20		x4



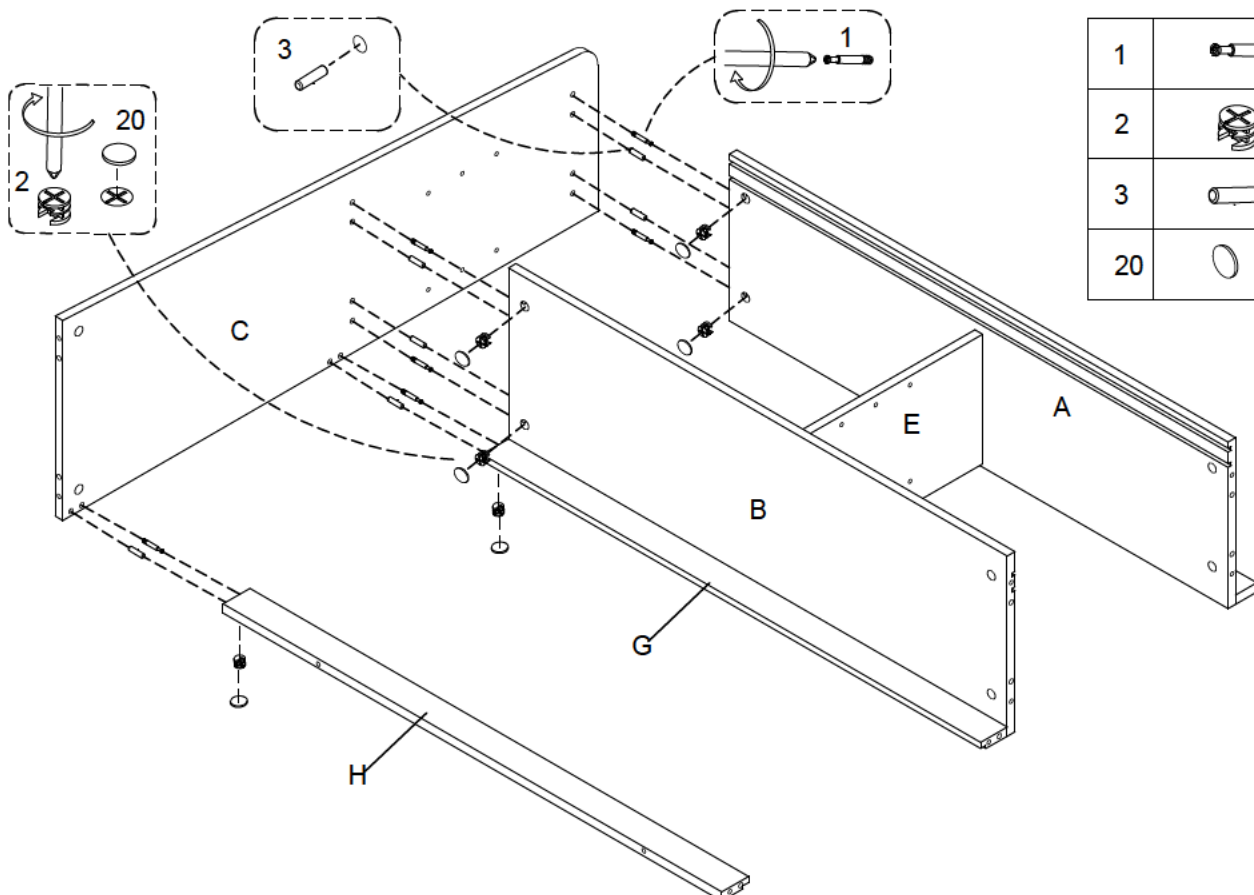

STEP 16



1		x6
2		x6
3		x6
20		x6

Assembly | Asambla | Assemblage

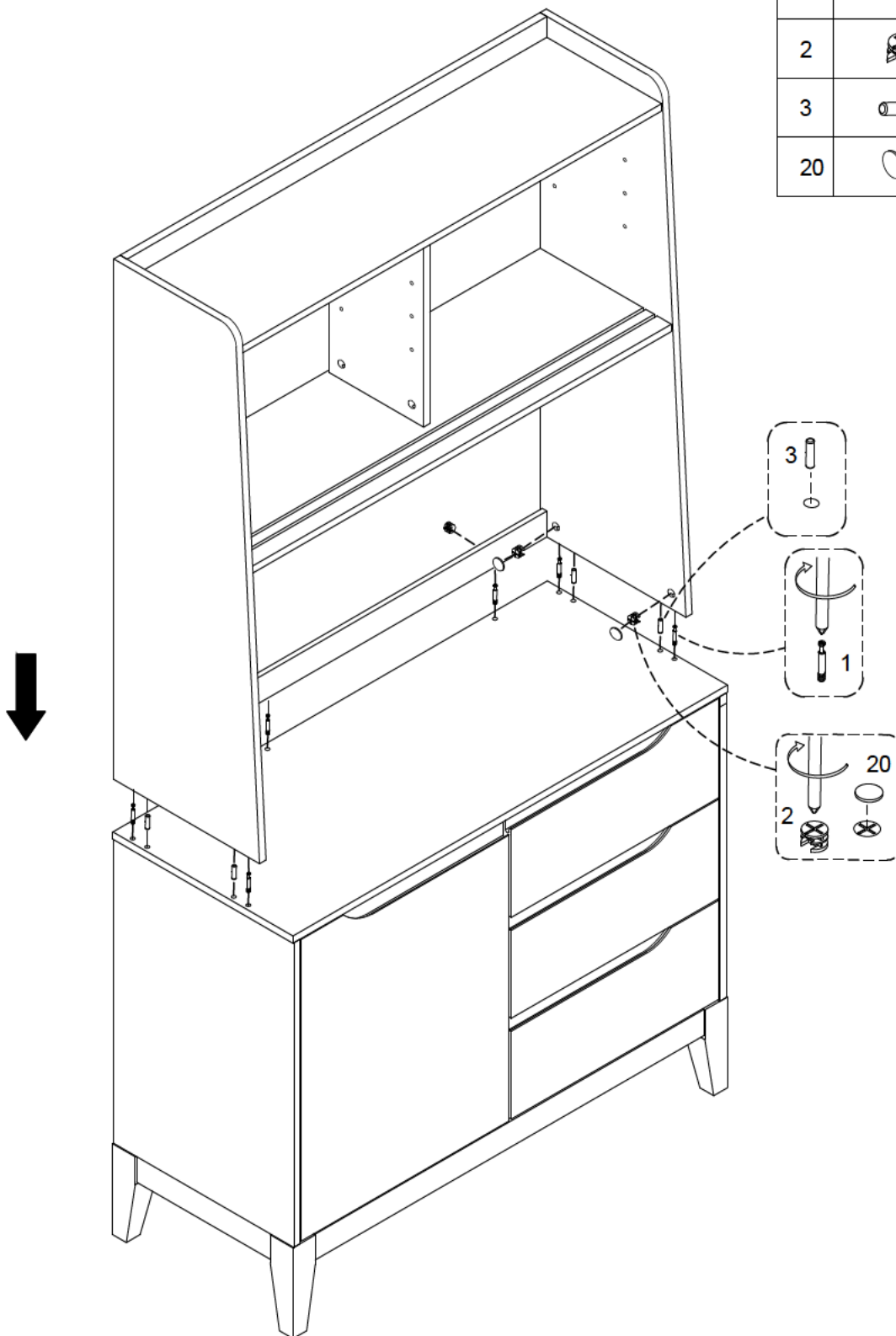

STEP 18

1		x6
2		x6
3		x4
20		x6



Assembly | Asambla | Assemblage

STEP 19

9		x34
10		x2

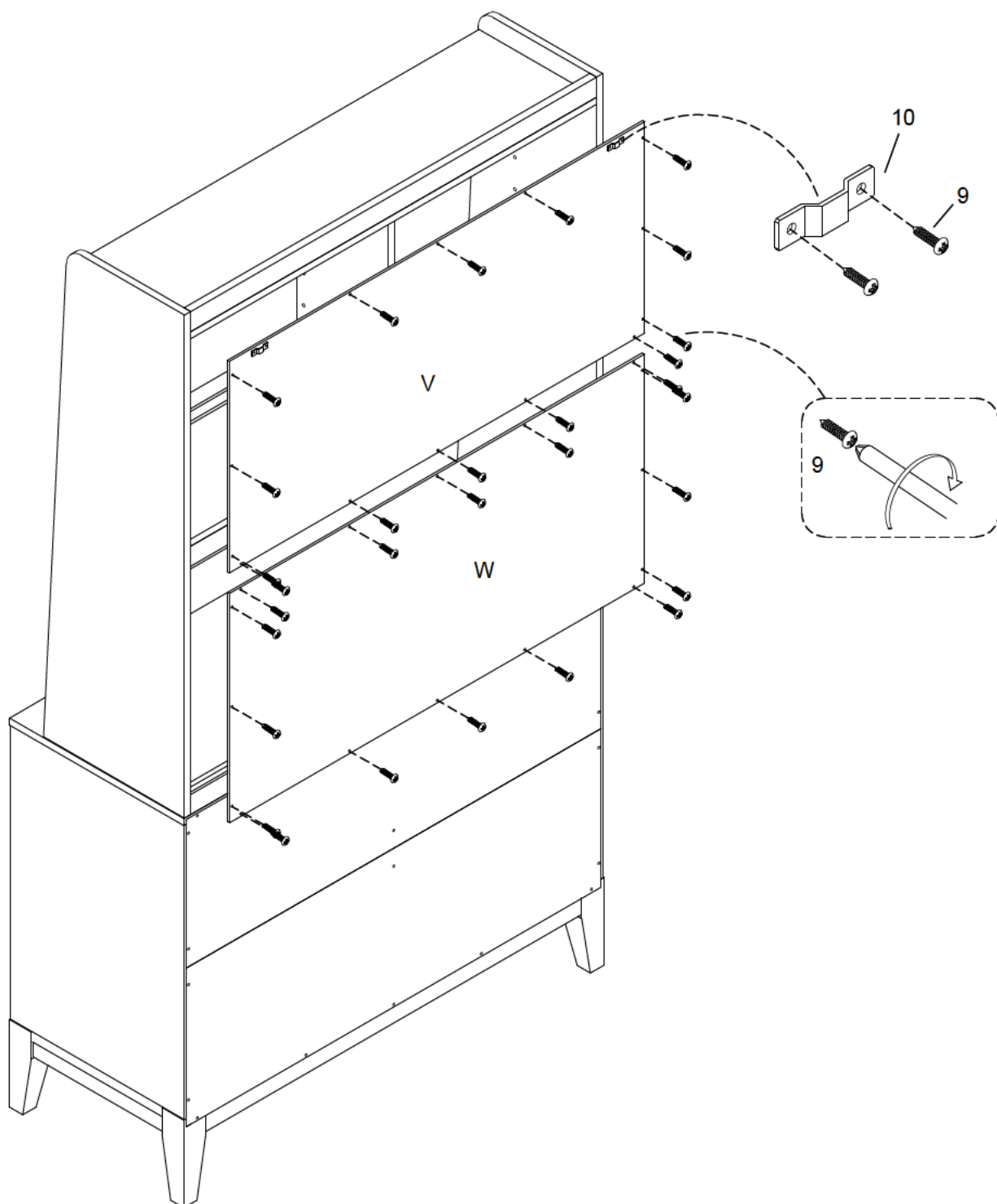

Assembly | Asambla | Assemblage

STEP 20

14		x8
----	---	----

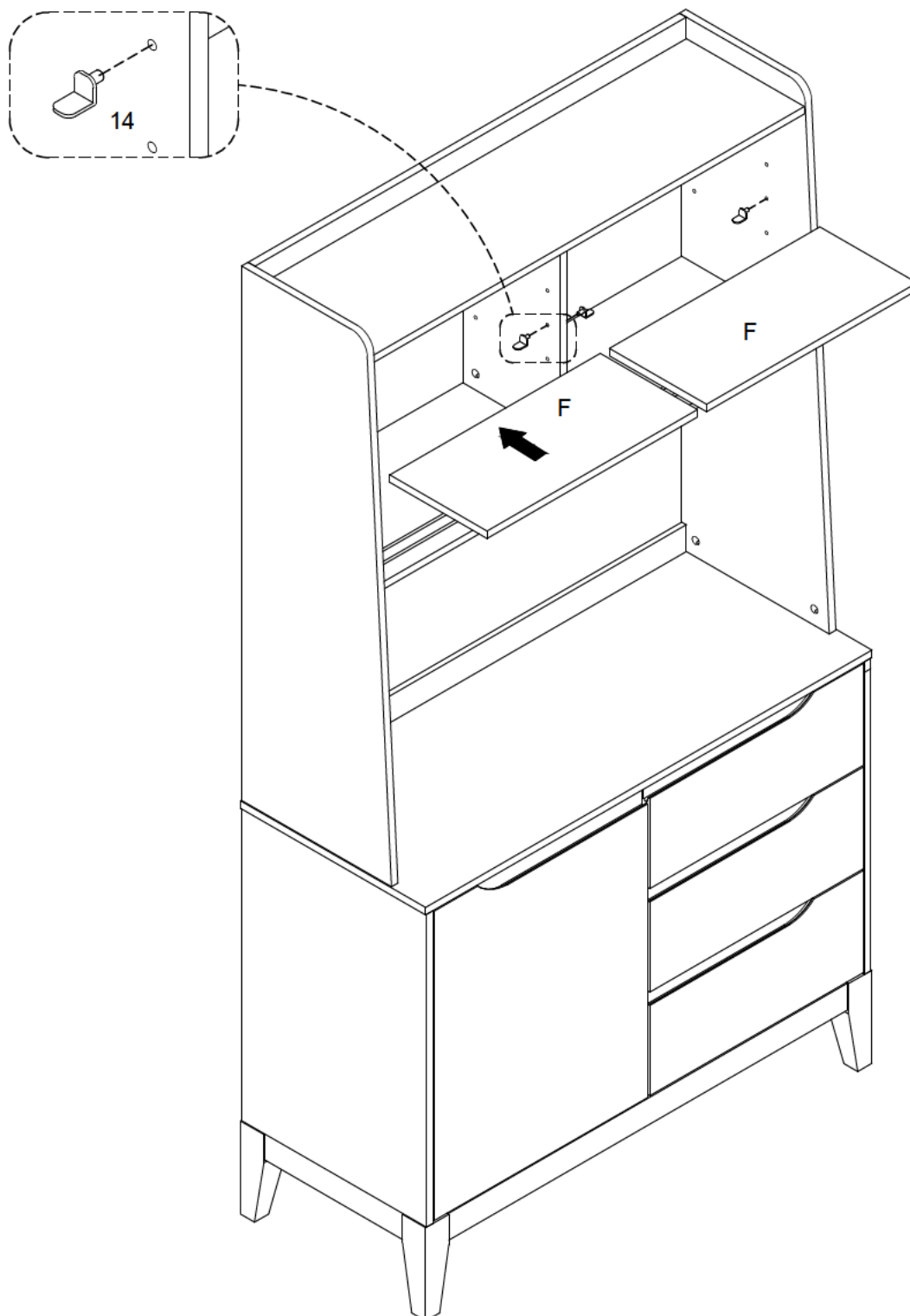

Assembly | Asambla | Assemblage

STEP 21

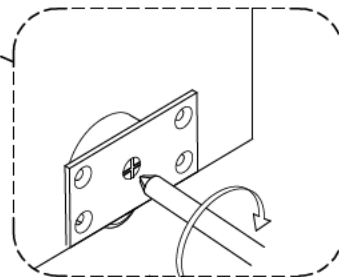
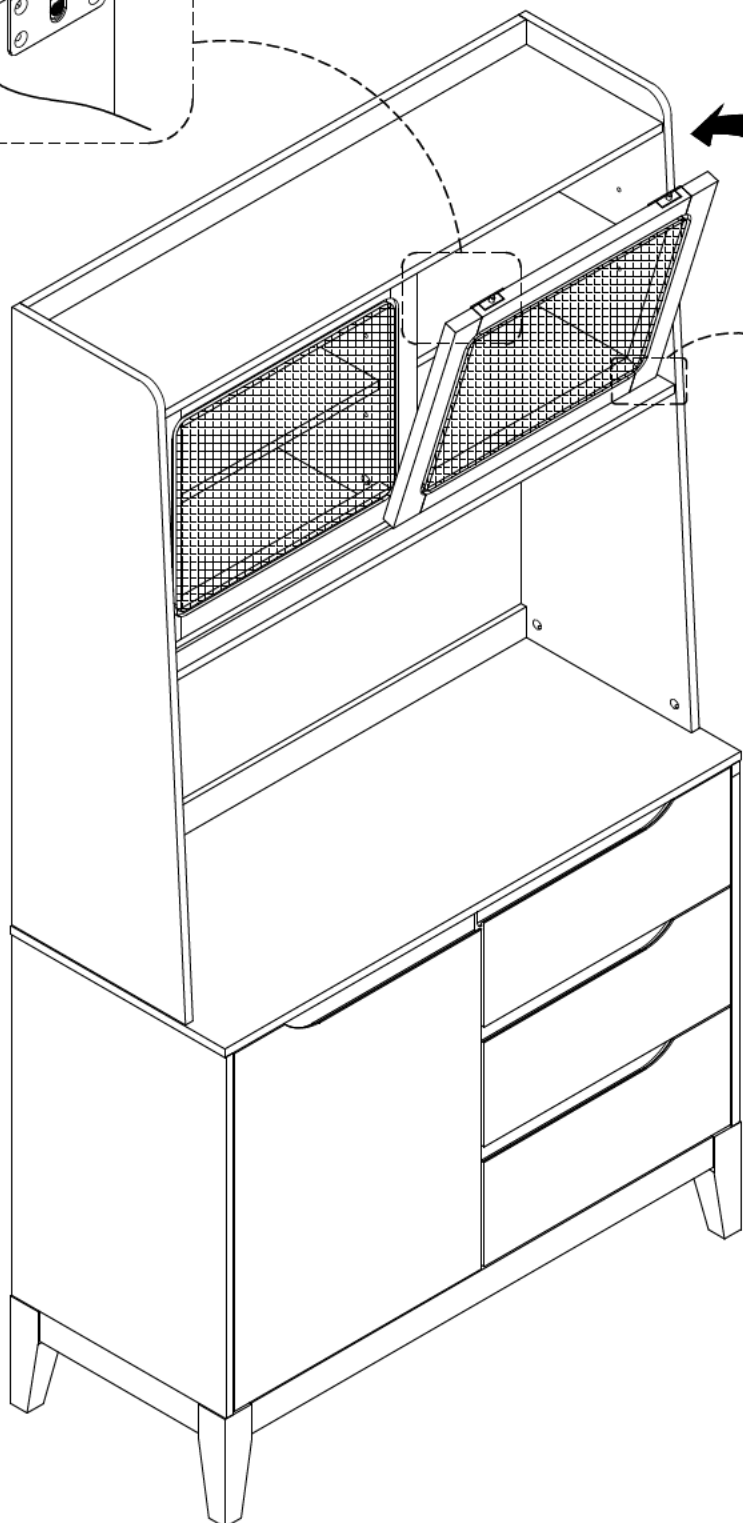
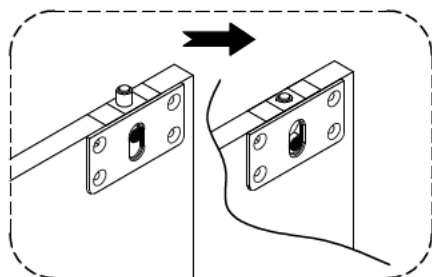

Balance each door by adjusting this screw.

Equilibre cada puerta ajustando este tornillo.

Équilibrez chaque porte en ajustant cette vis.

Assembly | Asambla | Assemblage

STEP 22

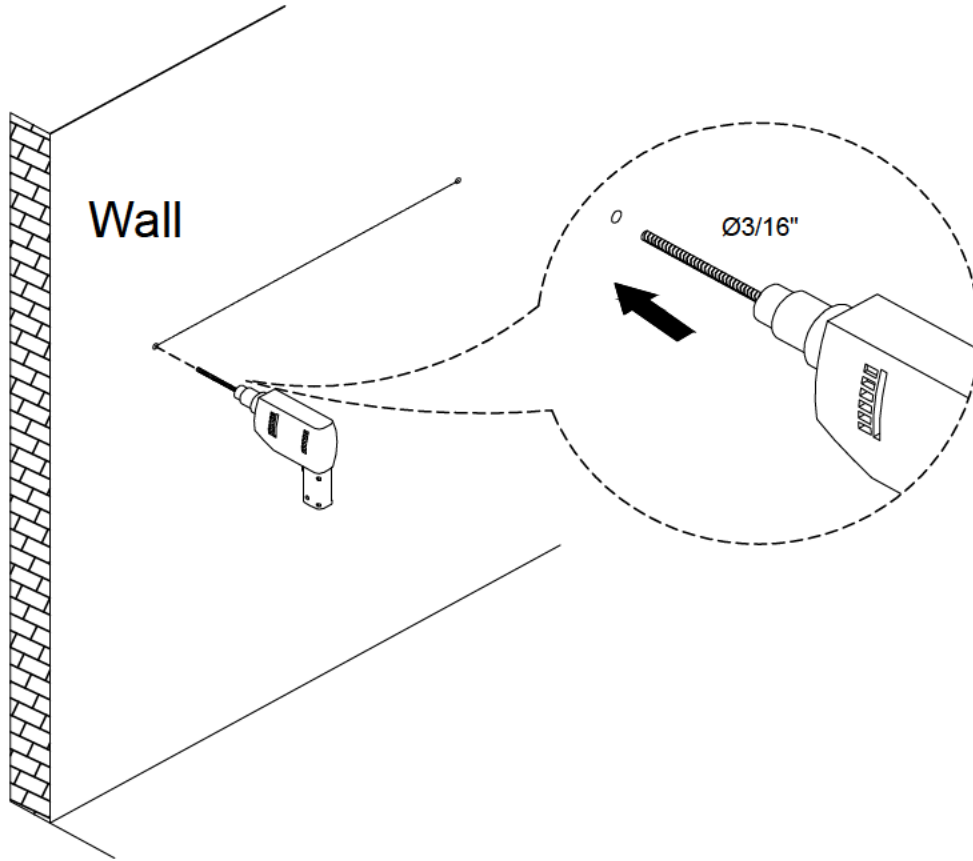

STEP 23

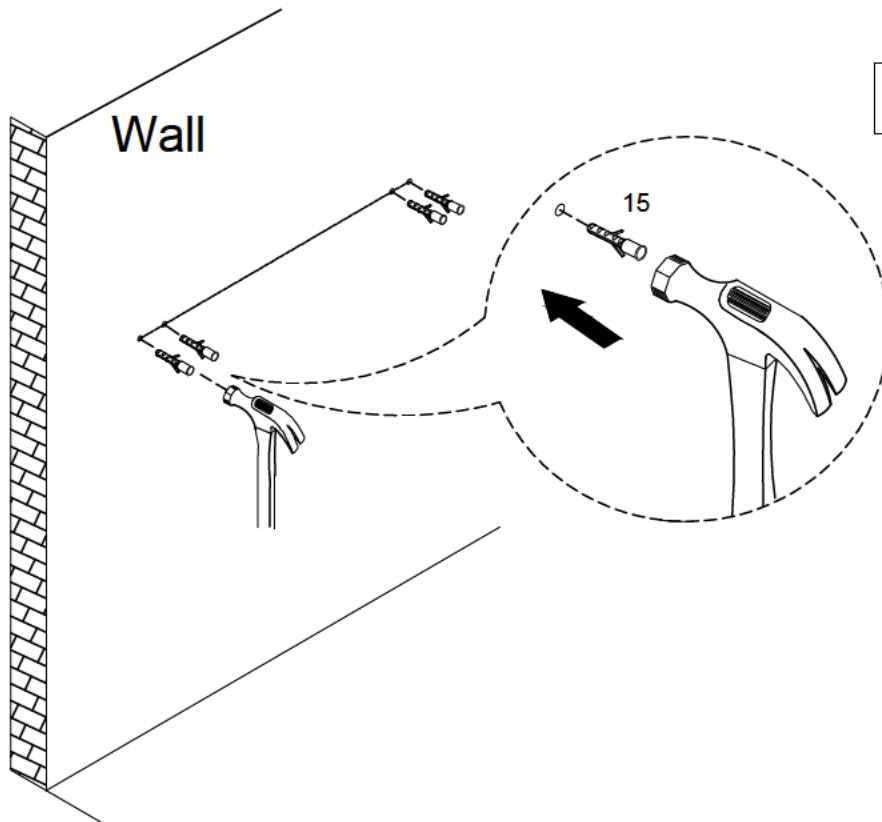

Assembly | Asambla | Assemblage

STEP 24

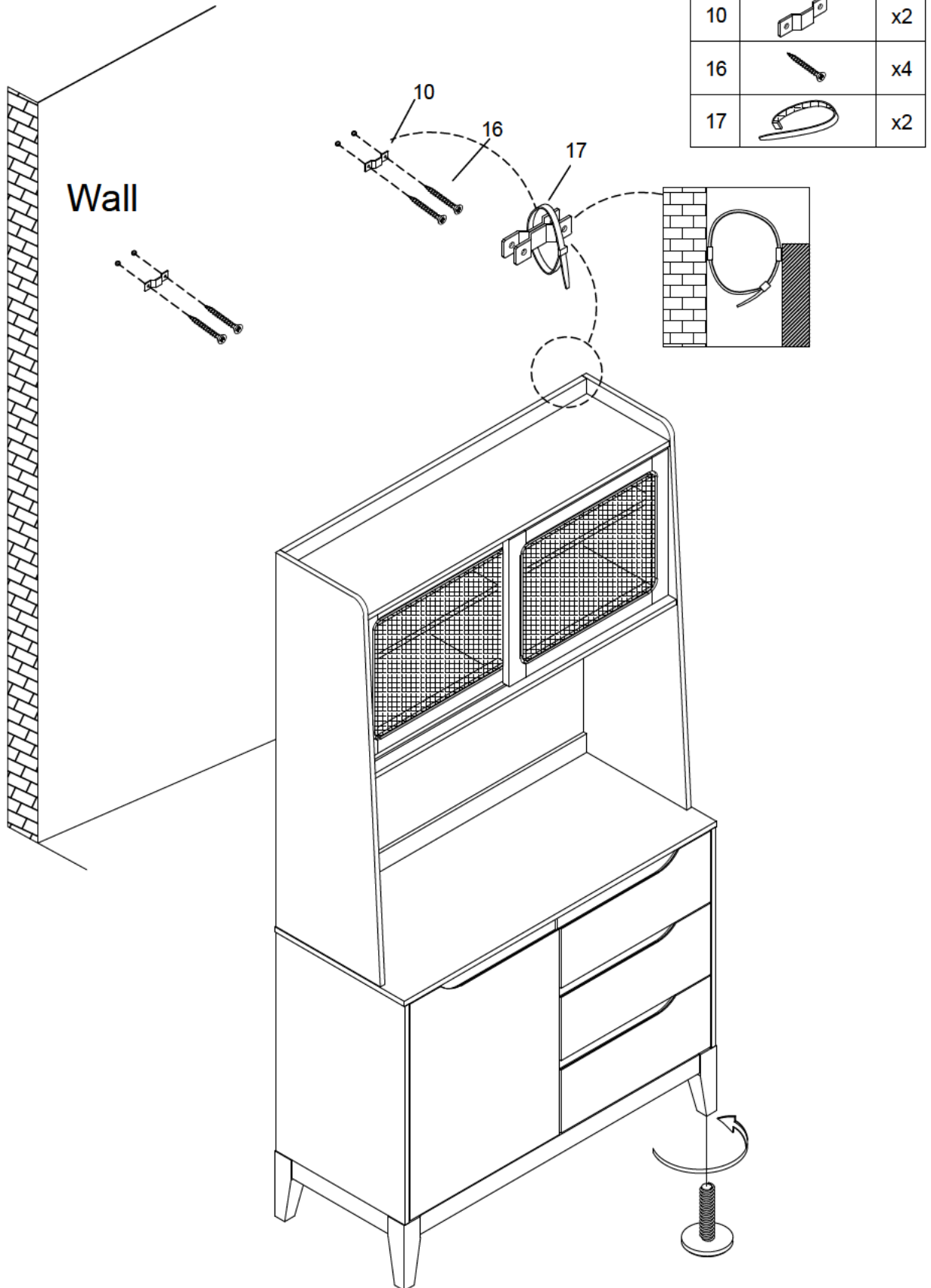

Replacement Parts or Damages

Requests for missing or damaged parts must be requested within one year of purchase. Damages or missing parts reported outside of one year will not be honored. Furniture is under no obligation to provide parts or replacement merchandise. Replacement part requests will not be honored for fully assembled or modified items.

One Year Limited Warranty

Product warranty applies to the original purchaser with items in original factory-sealed cartons. Proof of purchase date, price, and seller must be shown to validate the warranty. This warranty covers defects in manufacturing. It does not apply to any defects caused by negligence, misuse, accidental damage, or improper assembly. Glass and mirrors are excluded from this warranty. Warranty does not extend to cosmetic damage, accidents, misuse, abuse, or neglect. Liability for incidental or consequential damages is excluded to the maximum extent permitted by law.