

Ahokua

Assembly Instruction

Accent Cabinet

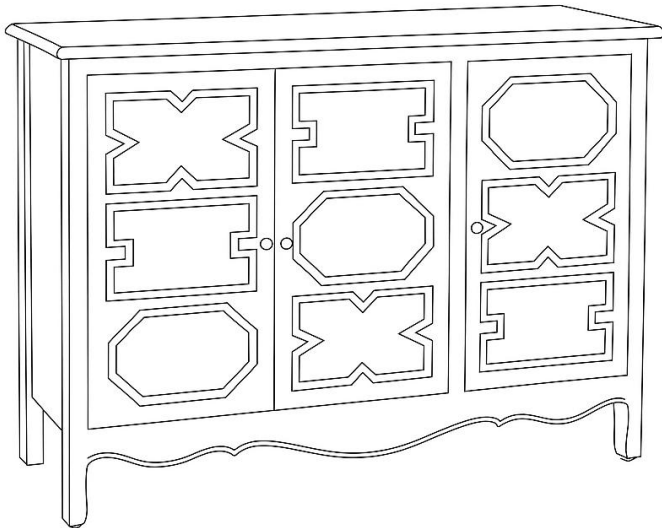









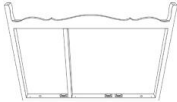

Thanks for buying this Living Room Furniture.

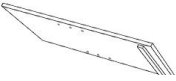
WARNING:

- Read all instructions carefully and completely before assembly and use.
- Retain for future reference.
- **DO NOT use power tools.**
- **DO NOT over-tighten hardware.**
- Periodically check all hardware and re-tighten as necessary.
- DO NOT use product if any component becomes damaged.
- For residential (non-commercial) use only.
- DO NOT sit or stand on product. Use only for intended purpose.
- DO NOT exceed 80lbs for the tabletop and 30lbs for the shelf, evenly distributed.

Parts List

Check all parts before assembly

<p>A. <u>Tabletop</u></p>  <p>*1</p>	<p>B. <u>Front panel</u></p>  <p>*1</p>	<p>C. <u>Back panel</u></p>  <p>*1</p>	<p>D. <u>Side panel</u></p>  <p>*2</p>
<p>E. <u>Bottom panel</u></p>  <p>*1</p>	<p>F. <u>Shelf</u></p>  <p>*1</p>	<p>H1. <u>Hex bolt</u></p>  <p>*8(+1 extra)</p>	<p>H2. <u>Washer</u></p>  <p>*8(+1 extra)</p>
<p>H3. <u>Alley key</u></p>  <p>*1</p>	<p>H4. <u>Foot pad</u></p>  <p>*4</p>	<p>H5. <u>Shelf pin</u></p>  <p>*4</p>	

Step 1: Put the Tabletop (A) on a soft surface to protect the finish.
Attach Back panel (C) to the Top (A) with Hex bolts (H1)&Washers (H2) using
Allen key (H3). **Leave hardware loose in this step**
Insert the Side panels (D) as shown below.

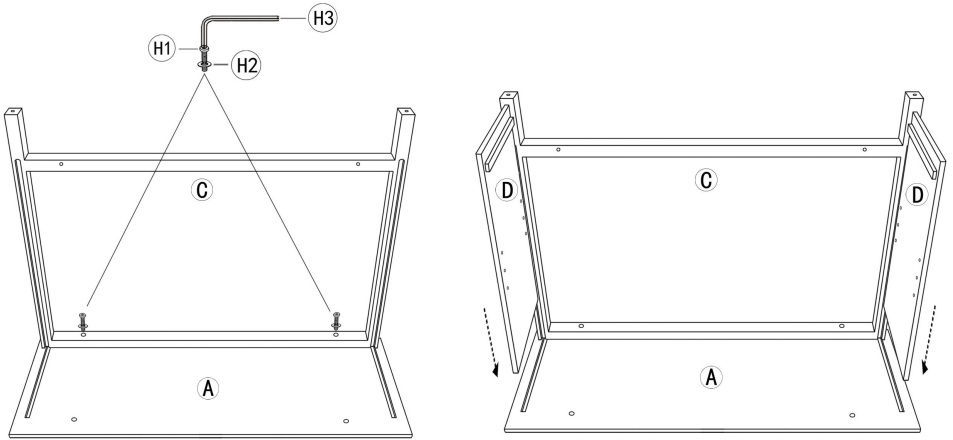

Step 2: Attach Front panel (B) to the Top (A) with Hex bolts (H1)&Washers (H2) using
Allen key (H3). Ensure the side panel (D) aligned with Groove on
the Front panel (B)&Back pane. **Leave hardware loose in this step.**

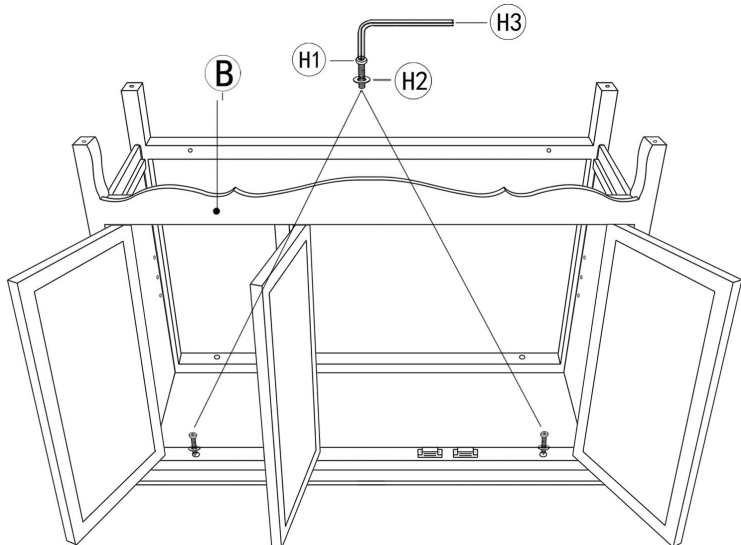

Step 3: Attach the Bottom panel (E) with Hex bolts (H1) and Washers (H2) by Allen key (H3) as shown below. **Fully tighten all bolts from Step 1 to 3.** Attach the Foot pad(H4) to the bottom of the legs.

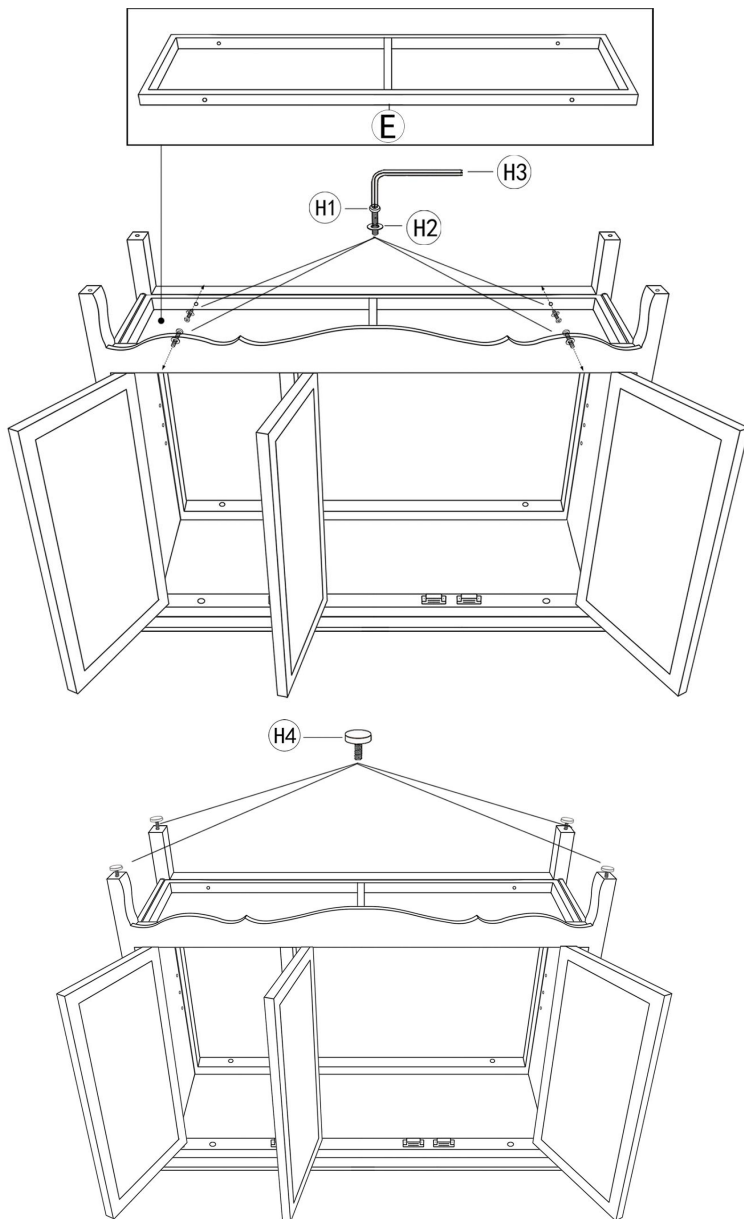

Step 4: Open the doors, insert the Shelf pins (H5) into the holes. Place the Shelf (F) inside as shown in picture below. (Each side panel with 6 adjustable holes.)

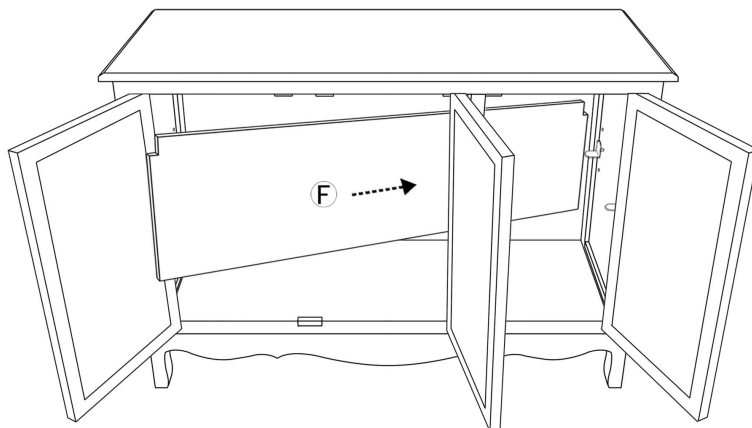
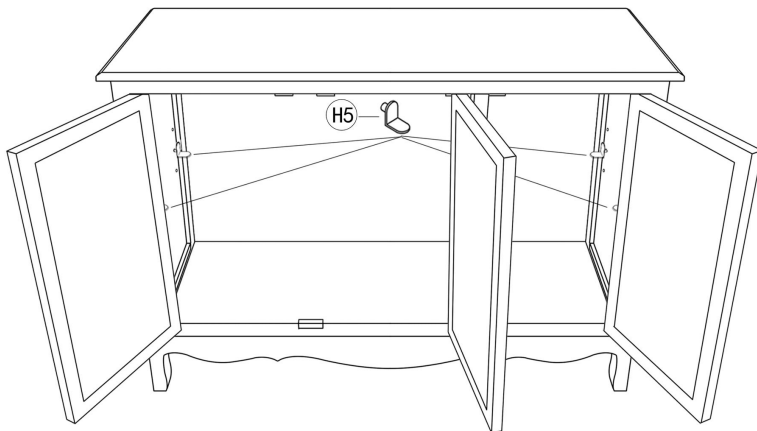

Assembly finished.

Notice:

If you encounter any issues during installation or use, please email us at support@mi-din.com, including your order ID and a detailed description of the problem. If possible, please provide relevant images to expedite assistance. We will strive to resolve any issues promptly.