

© Shire 4X6 Overlap 2018

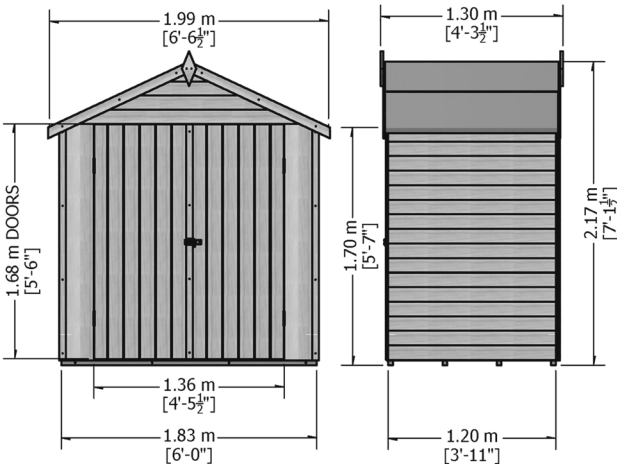

These instructions are for your safety. Please read through them thoroughly before use .
PLEASE KEEP THIS LEAFLET FOR FUTURE REFERENCE

Let's get started...

Important information...



Safety	03
Base and positioning	04
Warranty	04
Care maintenance & Recycling	05



In more detail...

Stacked and Fascia Parts List	06-07
Detailed Technical Drawings	08-09
Hardware	10-11
Before you start	11
Assembly instructions	12-24

EN	For a copy of the instructions or a copy in another language please send an email or write to the address below.
F	Pour obtenir un exemplaire des instructions ou une copie dans une autre langue s'il vous plaît envoyez un e-mail ou écrire à l'adresse ci-dessous.
PL	Na kopii instrukcji lub kopii w innym języku prosimy o wysłanie maila lub pisać na adres podany poniżej.
RUS	Для получения копии инструкции или копия на другом языке, пожалуйста, отправьте по электронной почте или написать по указанному ниже адресу.
TR	Başka bir dilde talimatları veya bir kopyasını bir kopyası için bir e-posta gönderebilir veya aşağıdaki adrese yazınız.

Check that you have noted all the following instructions



- We advise the use of non slip protective gloves throughout the assembly process.
- We advise the use of steel capped protective footwear throughout the assembly process
- We advise that you use a helper to hold the glass in position whilst you nail the beading in place
- We advise the use of protective headwear and safety goggles throughout the assembly process
- Where a ladder is in use another person must hold the ladder.
- Do not attempt to work in windy conditions
- We advise the use of a scaffold tower when fitting the roof, for felting or if you cannot reach from the ground.
- Do not allow children near the tools and work area
- Follow any safety precautions quoted by the manufacturer for any equipment you use
- Check all parts before assembly
- Only use child and animal safe wood preservative
- Do not use creosote
- Allow the wood preservative to fully dry before use
- Regularly check the building for wear and tear

Important!



EVERY PRECAUTION IS TAKEN TO ENSURE THAT YOUR BUILDING HAS NO ELEMENT INCORRECTLY PLACED OR POSSIBLY HAZARDOUS, HOWEVER PRIOR TO USE PLEASE CHECK ALL SURFACES FOR THE FOLLOWING:

- (1) RAISED GRAIN, SPLINTERS: Sand down timber to smooth finish
- (2) NAIL/SCREW/PIN HEADS PROUD: Tap home to be flush with surface of timber
- (3) DAMAGED SCREW HEADS RESULTING IN SHARP SPLINTERS OF METAL: Replace
- (4) SHARP ENDS OF NAILS/ SCREWS/ PINS PROTRUDING THROUGH THE PANEL: Remove and reposition.
- (5) ENSURE ALL PARTS ARE SECURED AGAINST REASONABLE FORCE: Remove and refit
- (6) ENSURE THERE ARE NO LOOSE PARTS: Remove and refit/discard



IMPORTANT ! For your safety please read carefully the safety warnings

Base and Warranty

Preparation of base...

We recommend that the base onto which your building will stand should be at least 75mm larger in each direction than the total floor size of the building.

Actual floor area of the building: 1828mm x 1197mm

Total height clearance: 2166mm

Roof size: 1994mm x 1302mm l

The chosen position in your garden for your building should be excavated to a depth of 75mm to allow a base of sand, on to which paving slabs can be evenly laid. You may also use an adjustable timber base or a concrete base. Whatever base you decide upon IT MUST BE LEVEL AND FIRM.

Warranty...

10 Year anti rot warranty subject to the following -

- The building must be raised so it is not in contact with any water retaining base surface (for example grass).
- This can be achieved using a timber, concrete or slab base
- When using a concrete or slab base use damp proofing strips under the bearers
- The building must have been completely treated and sealed immediately prior to or after assembly
- The building must have been re-treated and re-sealed annually
- If your building has been pressure treated or has any pressure treated parts additional treatment must still be applied .
- Wood is a natural product and therefore the following are excluded from the warranty
 - Colour changes
 - Warping
 - Splitting

The following are also excluded

- Damage resulting from poor assembly
- Poor treatment application
- Poor care and maintenance
- Changes to the design
- Misuse
- General wear and tear

The 5 golden rules of care

- (1) Ensure your base is level and firm
- (2) Ensure the building is not sitting directly on the ground using damp proof membrane or the optional timber base.
- (3) Ensure every piece of timber and surface, especially that is hidden upon assembly is treated with a top quality wood preservative at least twice (see note on pressure treated buildings in warranty section). Turn the panels upside down whilst painting so the treatment runs into the seams.
- (4) Garden buildings are not waterproof, therefore we recommend you seal between all the panels with a silicone based sealant .
- (5) Regularly check your roofing felt for weather damage and leaks

The 7 golden rules of maintenance

- (1) Re apply the timber treatment annually. (see note on pressure treated buildings in warranty section)
- (2) Visually check for weather damage
- (3) Check and replace if necessary any Silicone sealant if used on your building.
- (4) Check the roofing material for wear
- (5) The doors and windows may require periodical adjustment
- (6) Ensure your building is well ventilated especially during hot weather
- (7) During extremely hot periods humidify your building to prevent the timber from drying out .

Recycling and disposal



packaging

1. Pallet and timber widely recycled
2. Cardboard widely recycled
3. Plastic strapping subject to local regulations
4. Plastic sheeting subject to local regulations



Building

1. Timber widely recycled
2. Metal fixings widely recycled
3. Glass widely recycled
4. Roofing felt not currently recycled

Description
(part No) qty

Stacked parts list

FLOOR PANEL
(A0130)x01

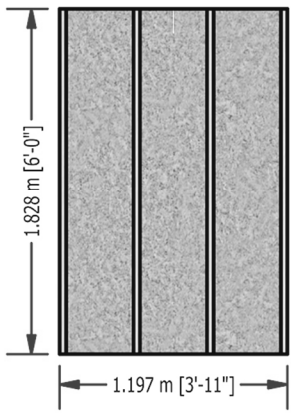

ROOF 1080X1209
(A0121)x02

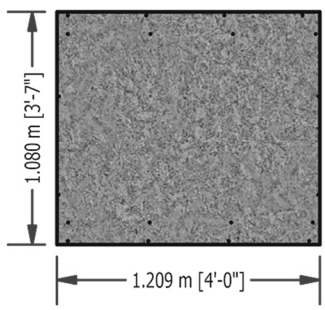

PLAIN PANEL 1197
(A1427)x02

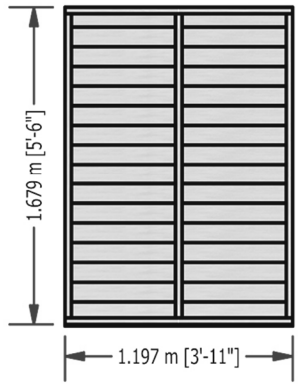

PLAIN PANEL 880
(A1428)x02

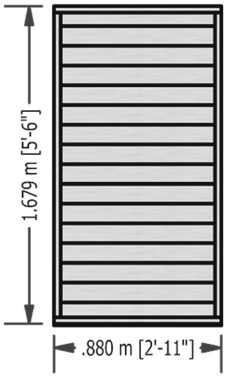

PLAIN WING 200
(A1429)x02

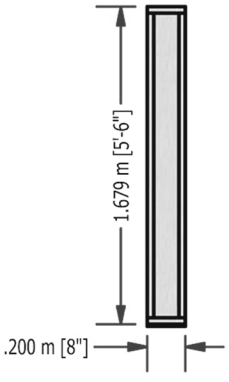

GABLE
(A0840)x02

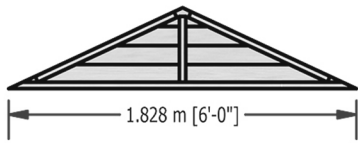

RUSTIC DOOR 674X1690
(A4257)x02

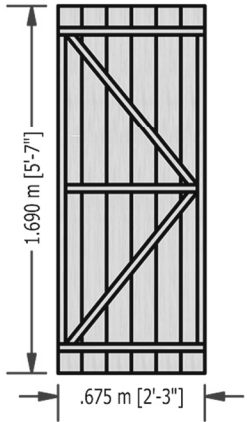

FELT STRIP 1.3M
(A0126)x03

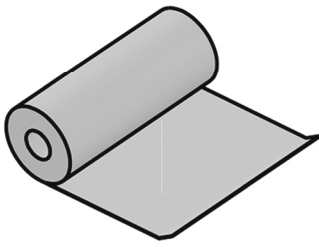

COVERSTRIP 12X48X1690
(A1432)x08

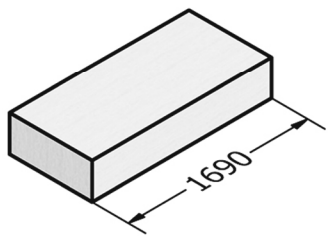

Stacked, Fascia & Nail bag contents

ROOF BEARER 34X34
(A0841)x02

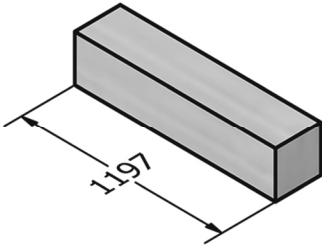

ROOF EDGE 34X34
(A0842)x02

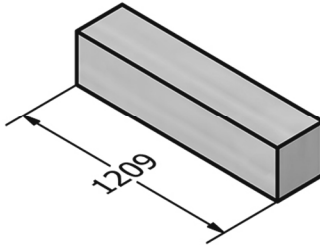

DOOR STOP 12X28X1360
(A0050)x01

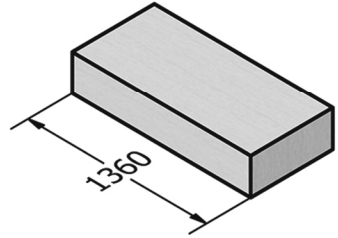

FASCIA 12X70X1145
(A0124)x04

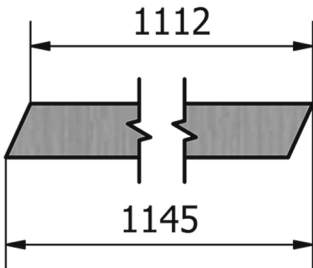

DIAMOND
(A0019)x02

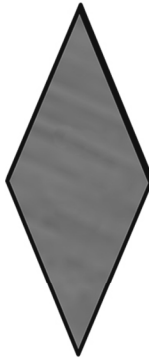

BLOCK 34X34X150
(A0065)x01

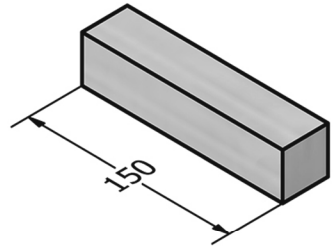

BOLT SPACER 12X48
(A0542)x02

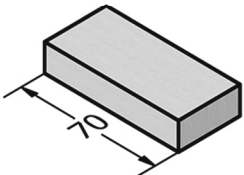

BARREL BOLT
(A0014)x02

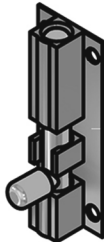

PAD BOLT
(A0053)x01

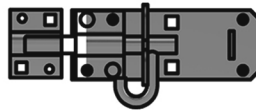

HURLING HINGE 4"
(A4241)x04

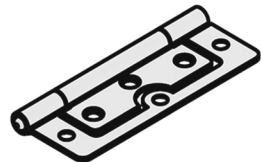

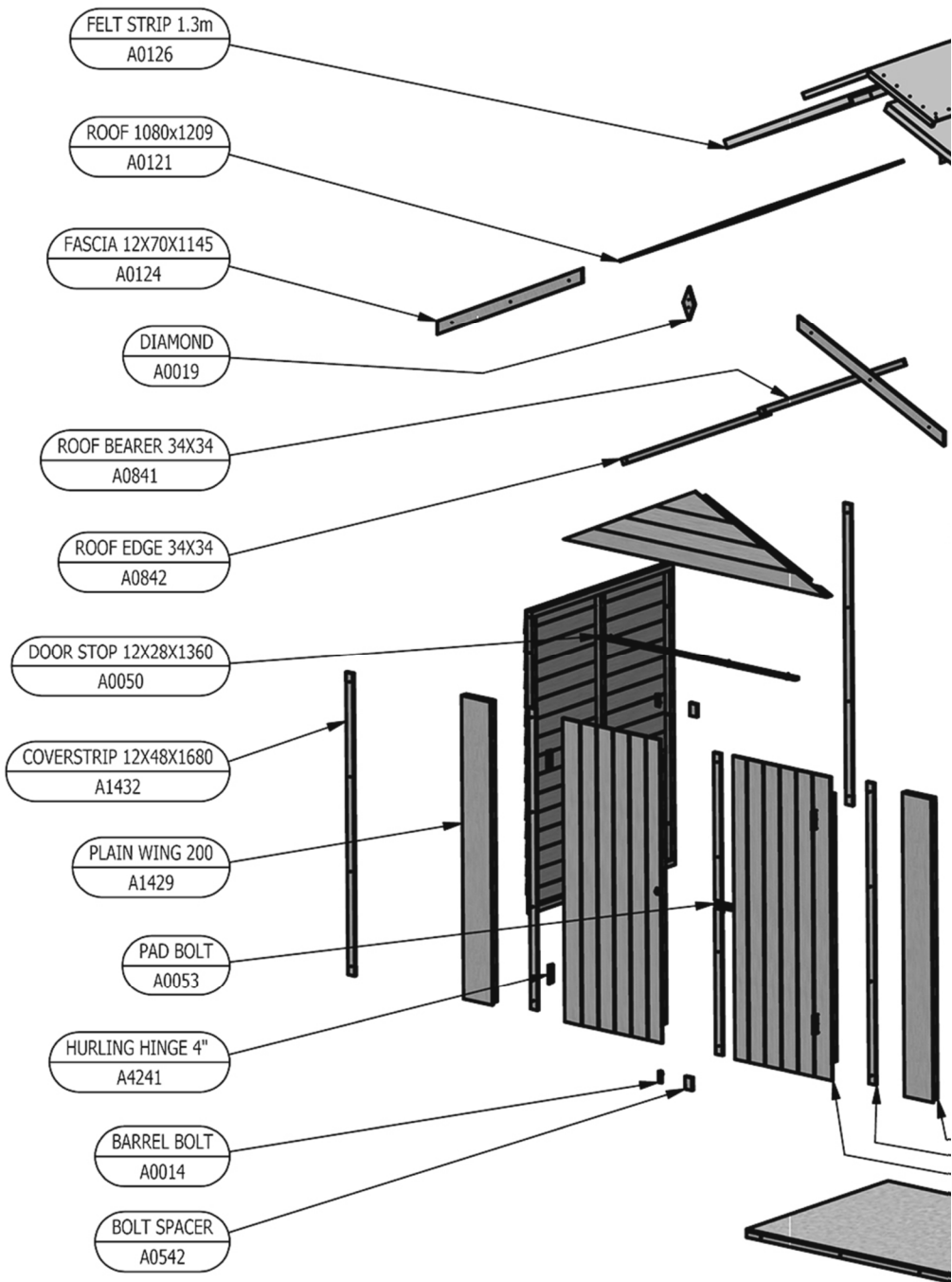

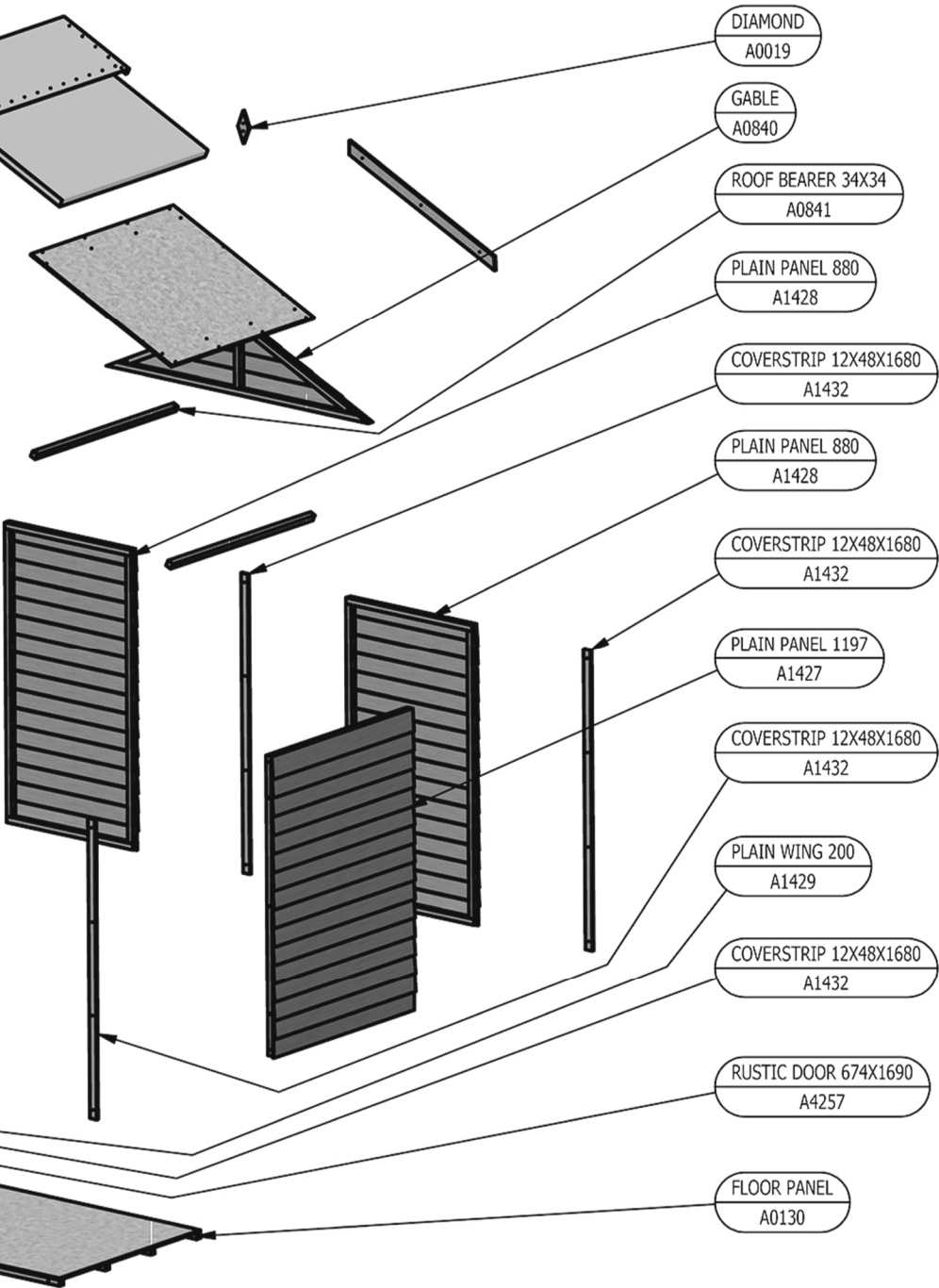

In more detail.....

Hardware Chart Scale 1:1

8mm Felt Nail
(A0266) x100



40mm Round head nail
(A0025) x96

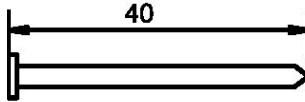

25mm Posi-drive screw
(A0032) x50

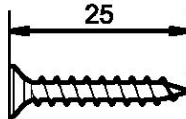

60mm Posi-drive screw
(A0035) x44

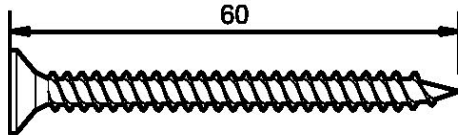

Things to check before you start

- ✓ Ensure your base is ready– See page 3
- ✓ Check all parts as listed in the parts lists
- ✓ Read the instructions fully before starting work
- ✓ Follow all the health and safety guidelines



6mm

When you see the drill icon

Only ever drill through the first piece of framework which will be a pilot hole for the screw to attach the second piece of framework

The required drill bit size is shown with the icon.

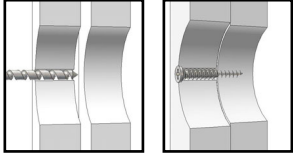

You will need



- Hammer



- Gloves

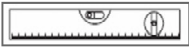

- Spirit level



- Saw



- Ladder

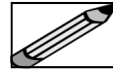

- Pencil

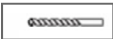

- 1mm, 3mm 5mm
- & 8mm drill bit

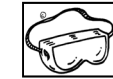

- Goggles



- Drill

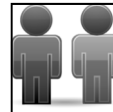

- A helper for some tasks

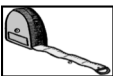

- Tape measure & Ruler



- Screwdriver



- Sand paper



- Safety knife

Assembly

These instructions are for your safety. Please read through them thoroughly before use .
Treat all the parts before assembly –see page 5

GB-IE The "Panel layout" is showing you how you layout the panels.

The door end panels and the opposite end panels FIT INSIDE THE SIDE PANELS!

01

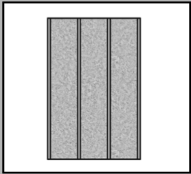

Floor panel
(A0130)x01

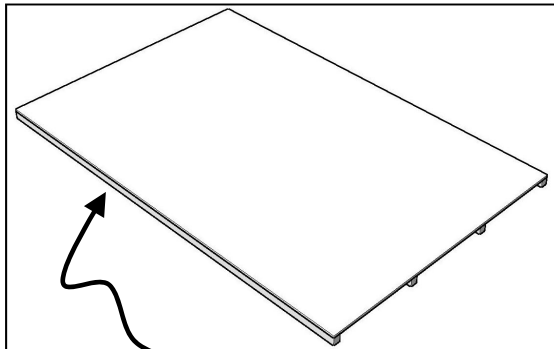
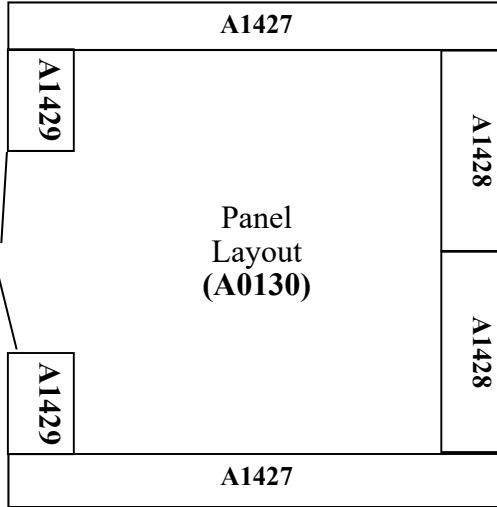

FRONT

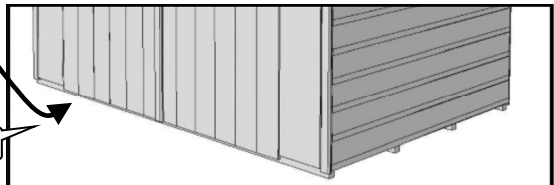

GB-IE

12

Place the **Floor Panel (A0130)** onto your chosen **base**.

Drill one **Plain Panel 1197 (A1427)**, making sure the holes are inline with the floor bearers.
Drill one **Plain Panel 880 (A1428)** as below.
Place the plain panel 1197 onto the floor, so that the cladding overlaps.
Push the plain panel 880 up to the 1197 panel and secure with 3x **60mm Screws (A0035)** using the pilot holes drilled.

02

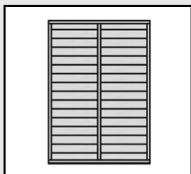
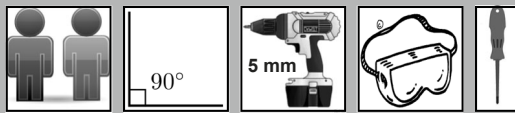

Plain Panel 1197 (A1427)x01

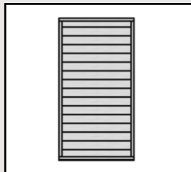

Plain Panel 880 (A1428)x01

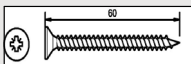

60mm Screw (A0035)x03

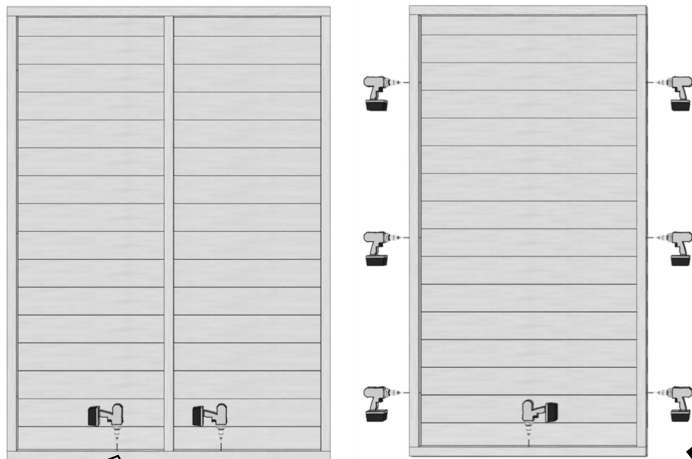

INLINE WITH FLOOR BEARERS

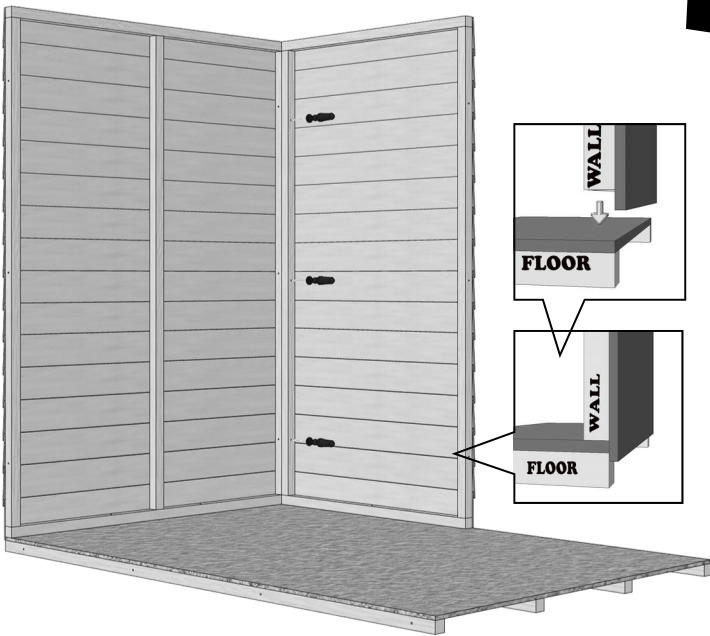

Drill the other **Plain Panel 880 (A1428)** as below. Place onto the floor, next to the other 880 panel and secure with 3x **60mm Screws (A0035)** using the pilot holes drilled in the other panel.

Drill the other **Plain Panel 1197 (A1427)**, making sure the holes are inline with the floor bearers as below. Place onto the floor and secure with 3x **60mm Screws (A0035)** as below.

03

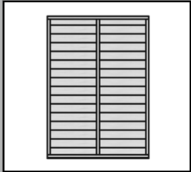
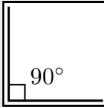
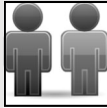

Plain Panel 1197 (A1427)x01

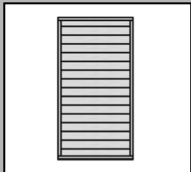

Plain Panel 880 (A1428)x01

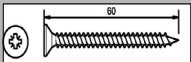

60mm Screw (A0035)x06



Drill the **Plain Wing 200 (A1429)** panels as below.
 Place onto the floor in between the plain panels 1197 as below.
 Secure with 3x **60mm Screws (A0035)** in each side.
 Note: May have to screw at an angle.

04

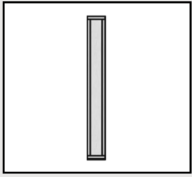

Plain Wing 200
(A1429)x02

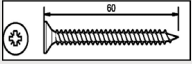

60mm Screw
(A0035)x06

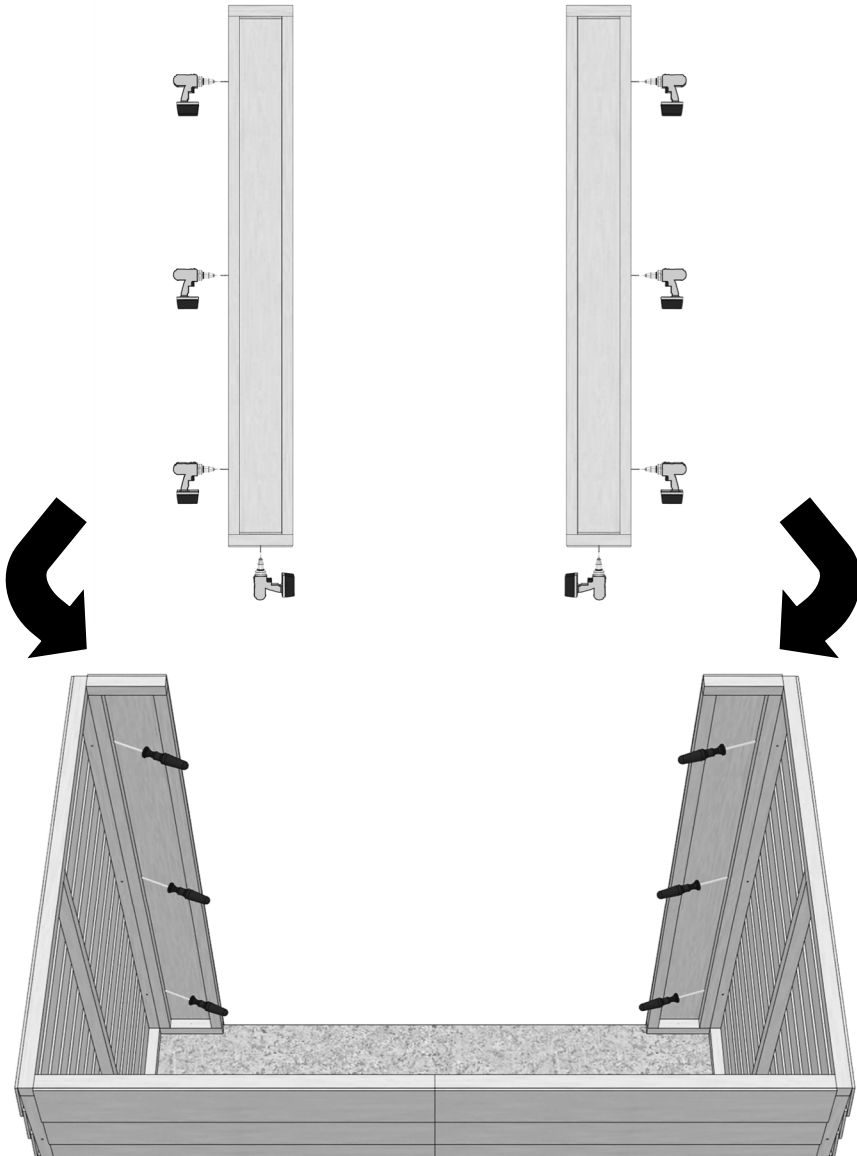
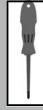
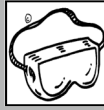
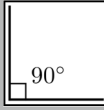

GB-IE

Place the **Gables (A0840)** onto the building so that the framework is flush. Secure with 4x **60mm Screws (A0035)** through the back gable as below. For the front gable, secure with 2 screws on the outer edges, then screw through the top of the wing panels as below.

05

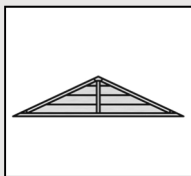

Gable (A0840)x02

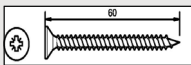

60mm Screw (A0035)x08

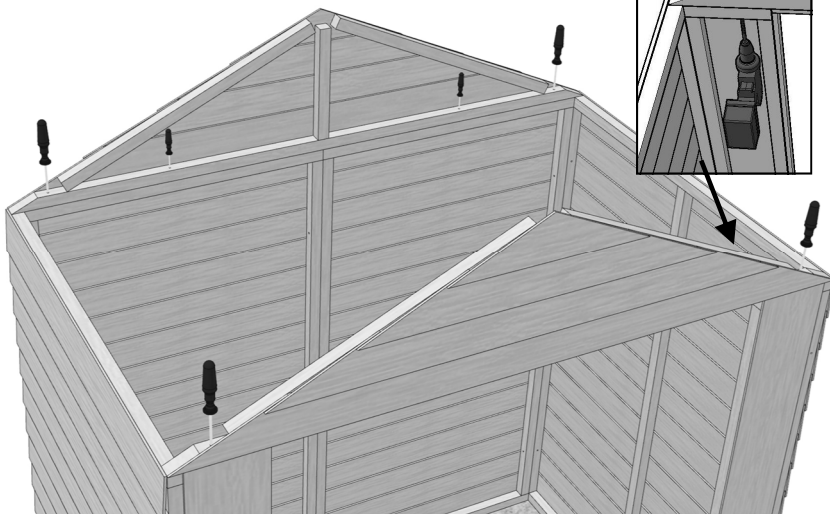
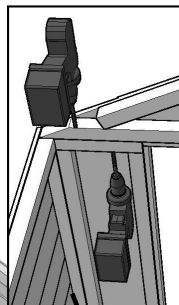
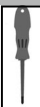
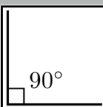

GB-IE

Place the **Roof Bearers 34x34 (A0841)** within the gable slots as below. Secure into the gable framework using 1x **60mm Screw (A0035)** in each end of the bearers as below. Then secure the two bearers together with 3x **60mm Screws (A0035)**.

06

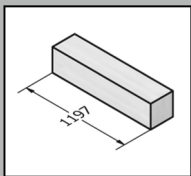

Roof Bearer 34x34 (A0841)x02

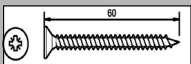

60mm Screw (A0035)x07

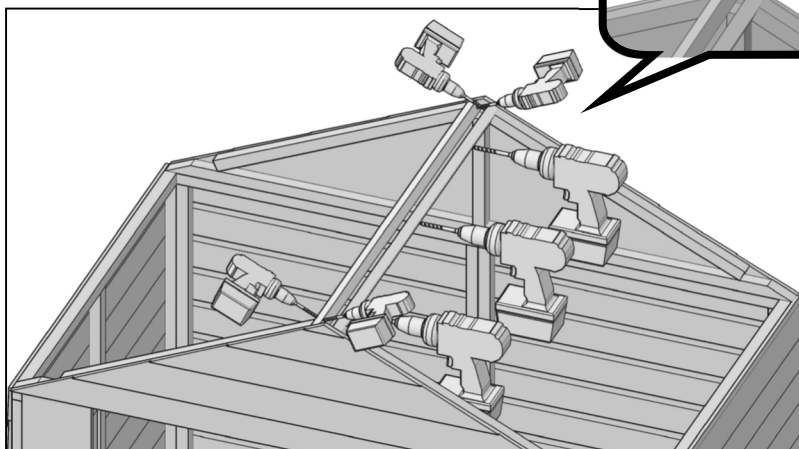
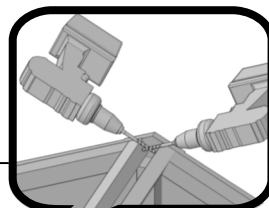
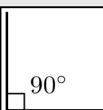

Fix one **Roof Edge 34x34 (A0842)** along the 1209mm edge of the **Roof 1080x1209 (A0121)** using 5x **40mm Nails (A0025)**. Repeat so you have 2 osb roof panels. Place onto the building as below. Make sure the top of the roof panel is flush with the top of the roof bearers. Secure the roof with 4x **40mm Nails (A0025)** along the top roof bearer. Fix with 4 nails along the side walls and 2 nails along each gable side. Repeat with the other roof panel.

07

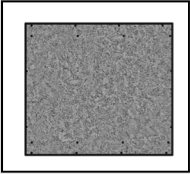
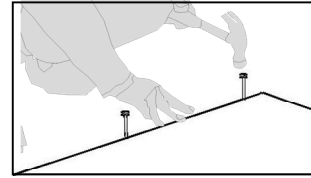

Roof 1080x1209
(A0121)x02

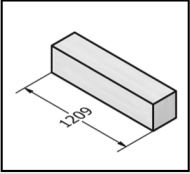

Roof Edge 34x34
(A0842)x02

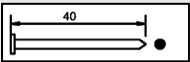

40mm Nails
(A0025)x34

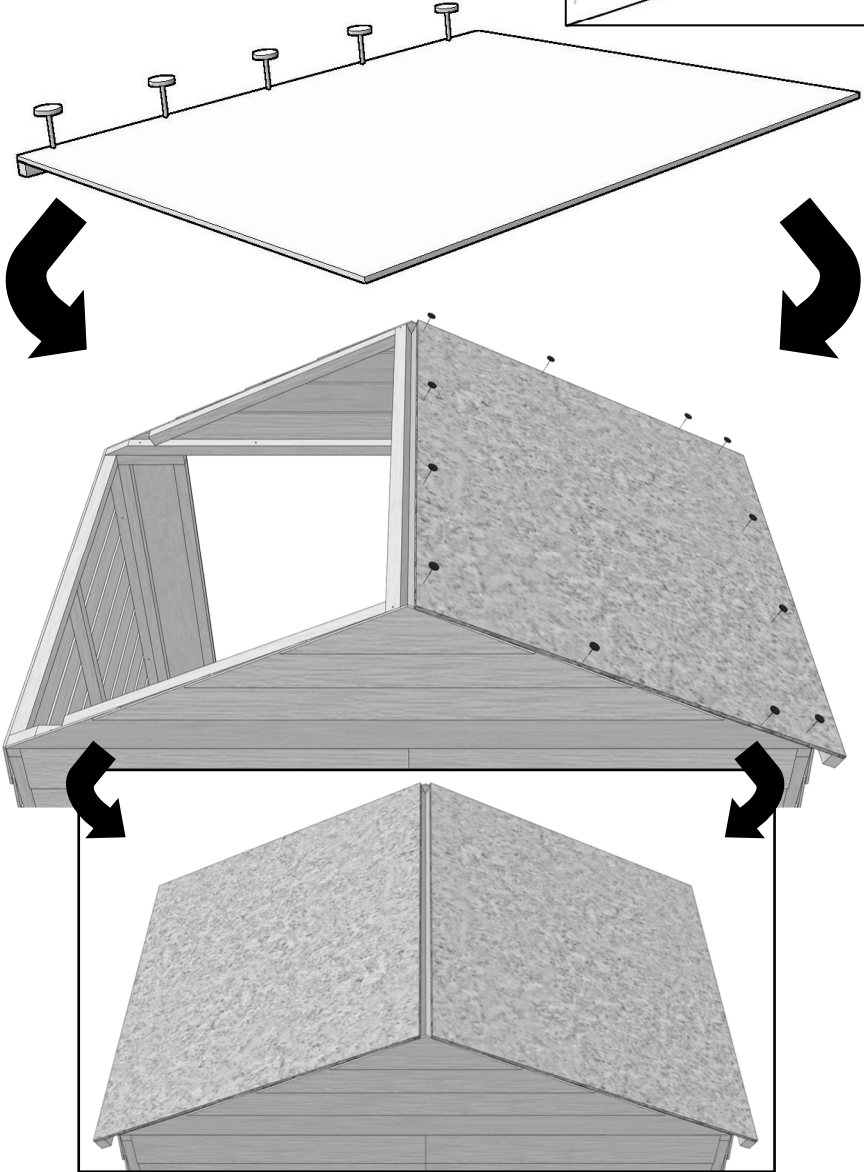

GB-IE

The larger outer part of the **Hurling Hinge 4"** (A4241) fixes to the **Rustic Door** (A4257) framework that is flush with the cladding on the end of the door. The round pivot part protrudes just over the cladding. The countersink must be facing outwards and fix with 3 screws through the outer hinge. Repeat.

08

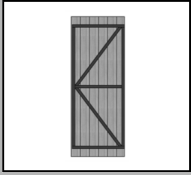

Rustic Door (A4257)x02

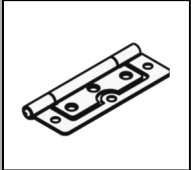

Hurling Hinge 4" (A4241)x04

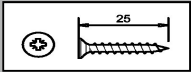

25mm screws (A0032)x12

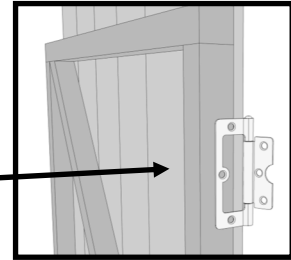
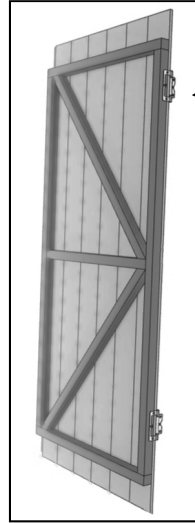
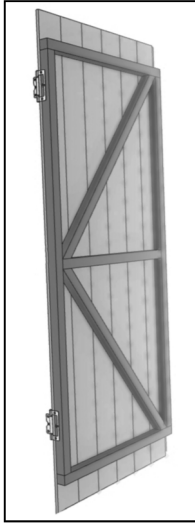
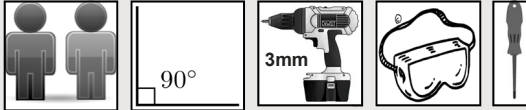

Carefully hang the doors using 1x 25mm **Screw (A0032)** per hinge at first to ensure they are square before adding the rest of the screws. The hinge fits to the end of the wing so only the round pivot is visible when the door is closed.

GB-IE

09

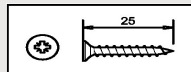

25mm screws (A0032)x12

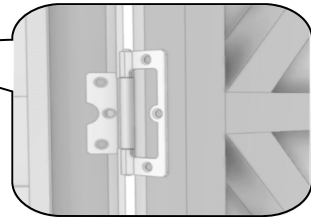
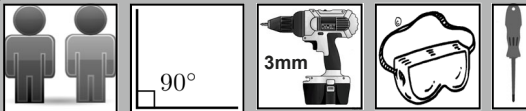

Make sure everything is square and true.

Fix the walls to the floor with 1x **60mm screw (A0035)** using the holes drilled previously.

10

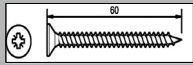

60mm Screw (A0035)x08

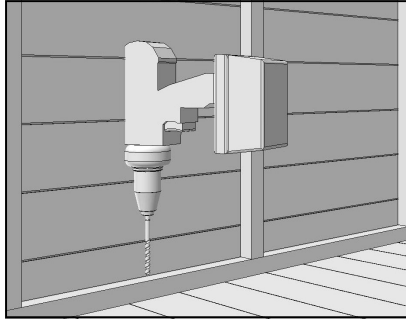
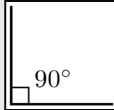

Fix the **Door Stop 12x28x1360 (A0050)** to the gable as below. Make sure the edge is flush with outside gable framework **NOT** the cladding. Secure with 4x **40mm Nails (A0025)**. Fix two **Coverstrips 12x48x1680 (A1432)** using 4x **40mm Nails (A0025)** to the wing Framework, making sure it stick outs to act as a door stop.

11

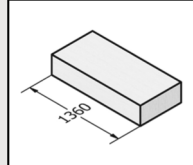

Door Stop 12x28x1360 (A0050)x01

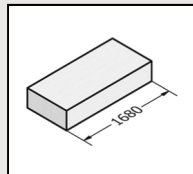

Coverstrip 12x48x1680 (A1432)x02

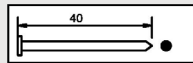

40mm Nails (A0025)x12

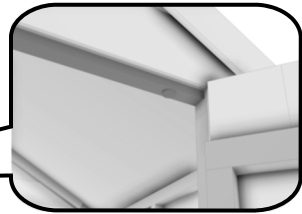
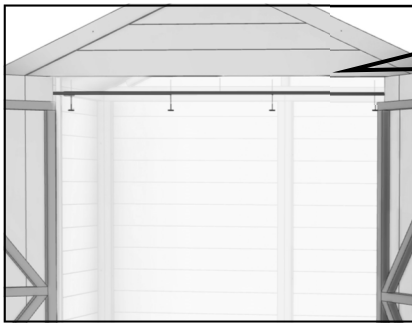

Fit a **Barrel Bolt (A0014)** to the top and bottom of the secondary door with a **Bolt Spacer (A0542)** between the bolt and the door using 4x **25mm Screws (A0032)**.

Make sure the screws go through the door bolt and the shim directly into the door.

Then drill an 8mm hole for the bolt shaft. Repeat for bottom of the door.

12

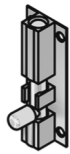

Barrel Bolt (A0014)x02

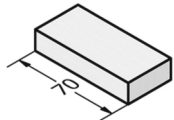
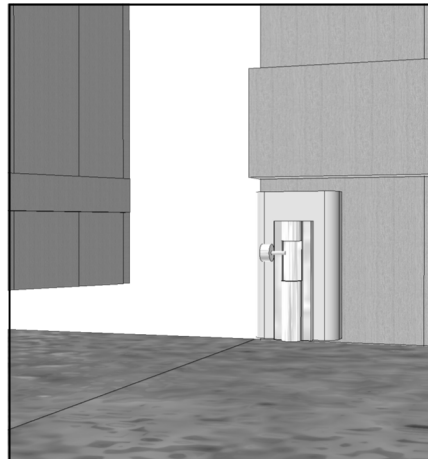
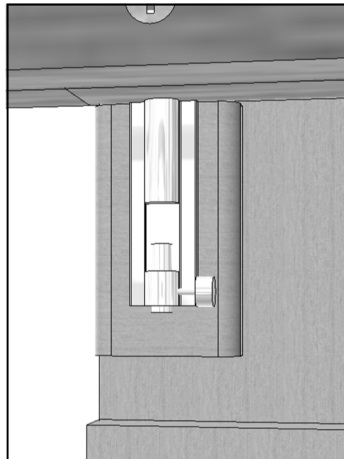

Bolt Spacer (A0542)x02

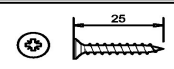

25mm screws (A0032)x08

Fix the **Block 34x34x150 (A0065)** to the middle bar on the back of the primary door as below.

Secure with 2x **60mm Screws (A0035)**.

13

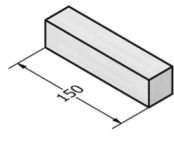
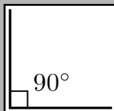

Block 34x34x150 (A0065)x01

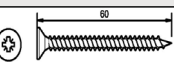

60mm Screw (A0035)x02

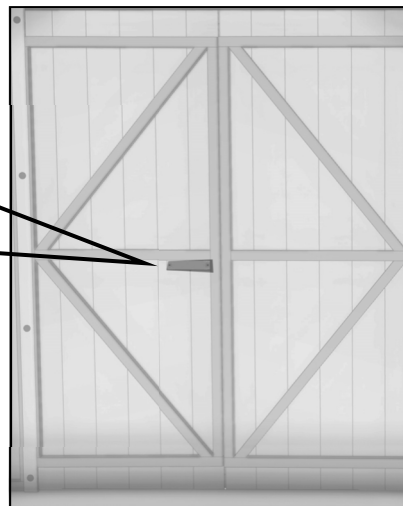
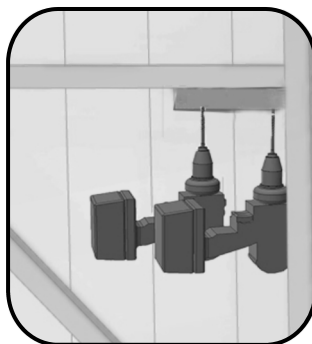

GB-IE

Fix the **Pad Bolt (A0053)** to the primary door as below.
 Secure with **4x 25mm Screws (A0032)**.
 Fix the catch to the secondary door using **2x 25mm Screws (A0032)**.

14

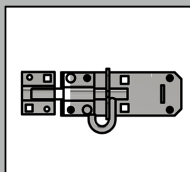
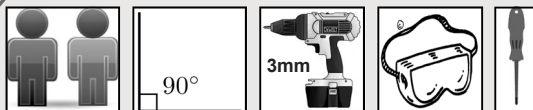

Pad Bolt (A0053)x01

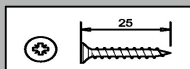

25mm screws (A0032)x06

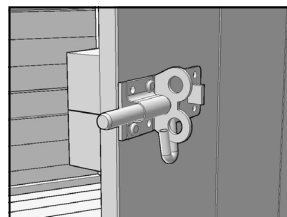
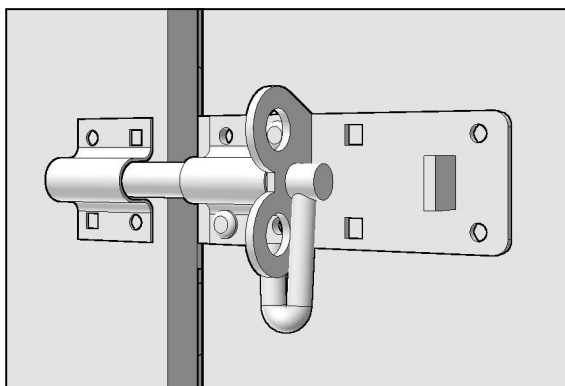

GB-IE

Take one **Coverstrip 12x48x1680 (A1432)** and place against the primary door.
 Mark above and below the pad bolt as below. Cut this section out so you have two pieces.
 Secure to the top and bottom of the primary door using **3x 25mm Screws (A0032)** in each.
 Make sure the strip covers over the secondary door slightly to close the gap.

15

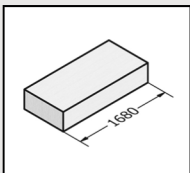

Coverstrip 12x48x1680 (A1432)x02

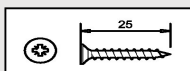

25mm screws (A0032)x06

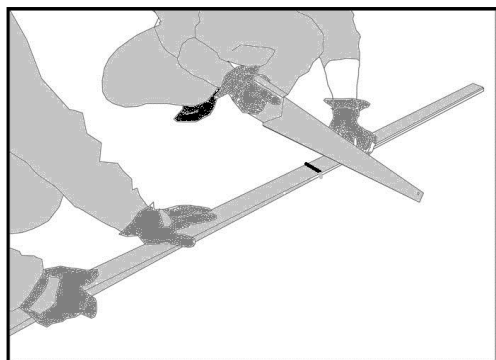
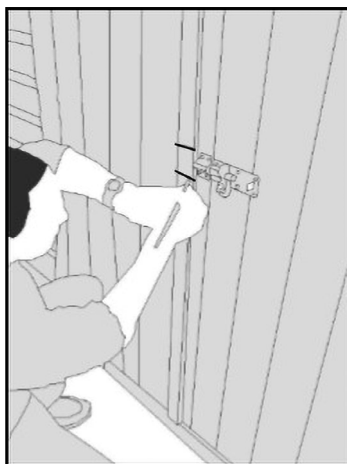

3 Strips of **Felt 1.3m (A0126)** have been supplied .

Fit the 2 lower strips first folding the felt over the roof edging, with an even overhang front and back then secure with a couple of nails at the top to hold the felt in position and at the bottom nail at approximately 100mm centres using **8mm Felt Nails (A0266)**.

The third piece overlaps the lower pair and goes over the ridge. Nail at approximately 100mm centres.

16

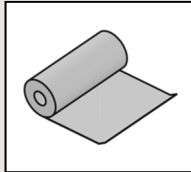

Felt Strip 1.3m
(A0126)x03

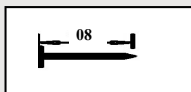

8mm Felt Nails
(A0266) x96

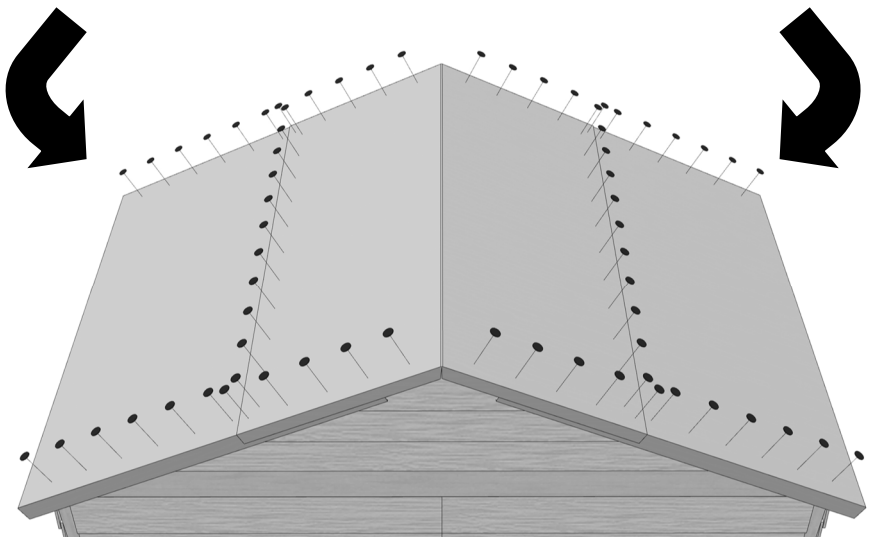
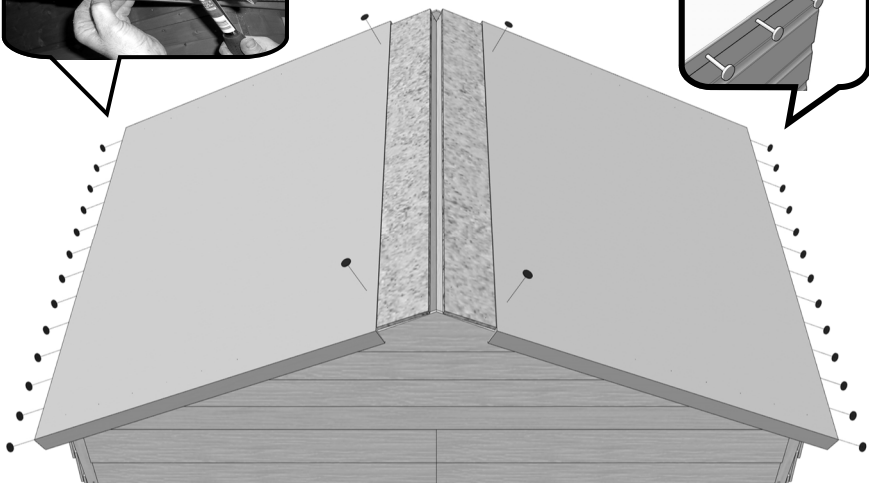
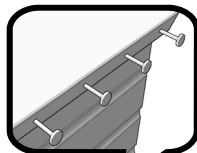
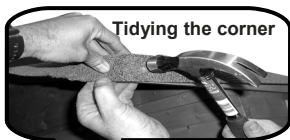
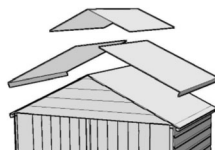
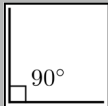

17

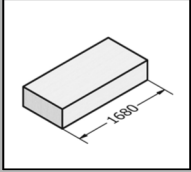

Coverstrip 12x48x1680 (A1432)x05

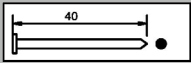

40mm Nails (A0025)x20

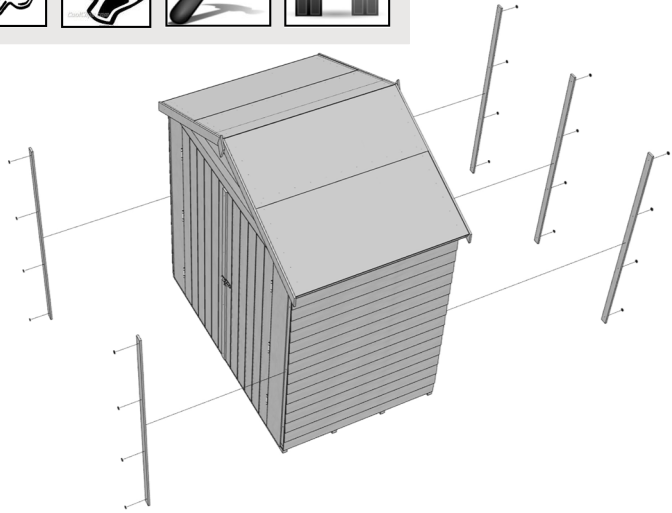

Fix the **Fascia 12x70x1145 (A0124)** to the front and back of the building as below using **3x 40mm Nails (A0025)** in each.
Fix the **Diamonds (A0019)** using **2x 40mm Nails (A0025)**.

18

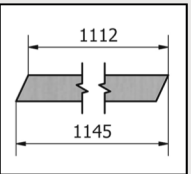

Fascia 12x70x1145 (A0124)x04

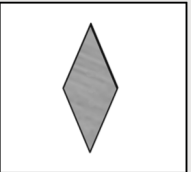

Diamond (A0019)x02

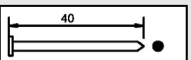

40mm Nails (A0025)x16

