

ASSEMBLY INSTRUCTION

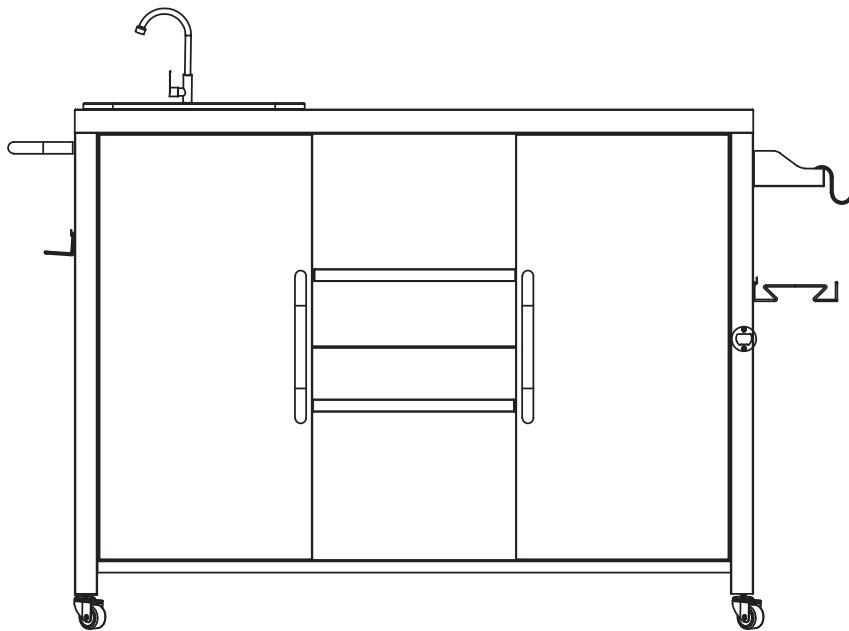







Grill Cart with Sink



Assembly Instructions

Caution : You must read this before you proceed

Care & Maintenance

- ⊘  ● Not for commercial use. For residential use only.
- ⊘  ● Do not put hot items directly on furniture surface.
- ⊘  ● Do not clean furniture with harsh cleansers or polish.
- ✓  ● To obtain the longest lifespan of your outdoor products, minimizing exposure to direct sunlight is recommended.
- ⊘  ● Children should not climb or jump on the furniture.
- ⊘  ● Do not write on furniture without a padded barrier to protect the surface.
- ✓  ● To obtain the longest lifespan of your outdoor products, avoid extended and lengthy exposure to rain, snow, and direct sunshine. Whenever possible cover the product and /or place under patio or awnings.
- ⊘  ● Stains may be removed with mild soap solution and damp cloth.
- ✓  ● Dust and pick-up spills using a clean, non-colored, lint-free cloth.

Please look in Mobile washbasin for hardware packs and legs.
Sets often ship in multiple boxes and may arrive a day or two apart.



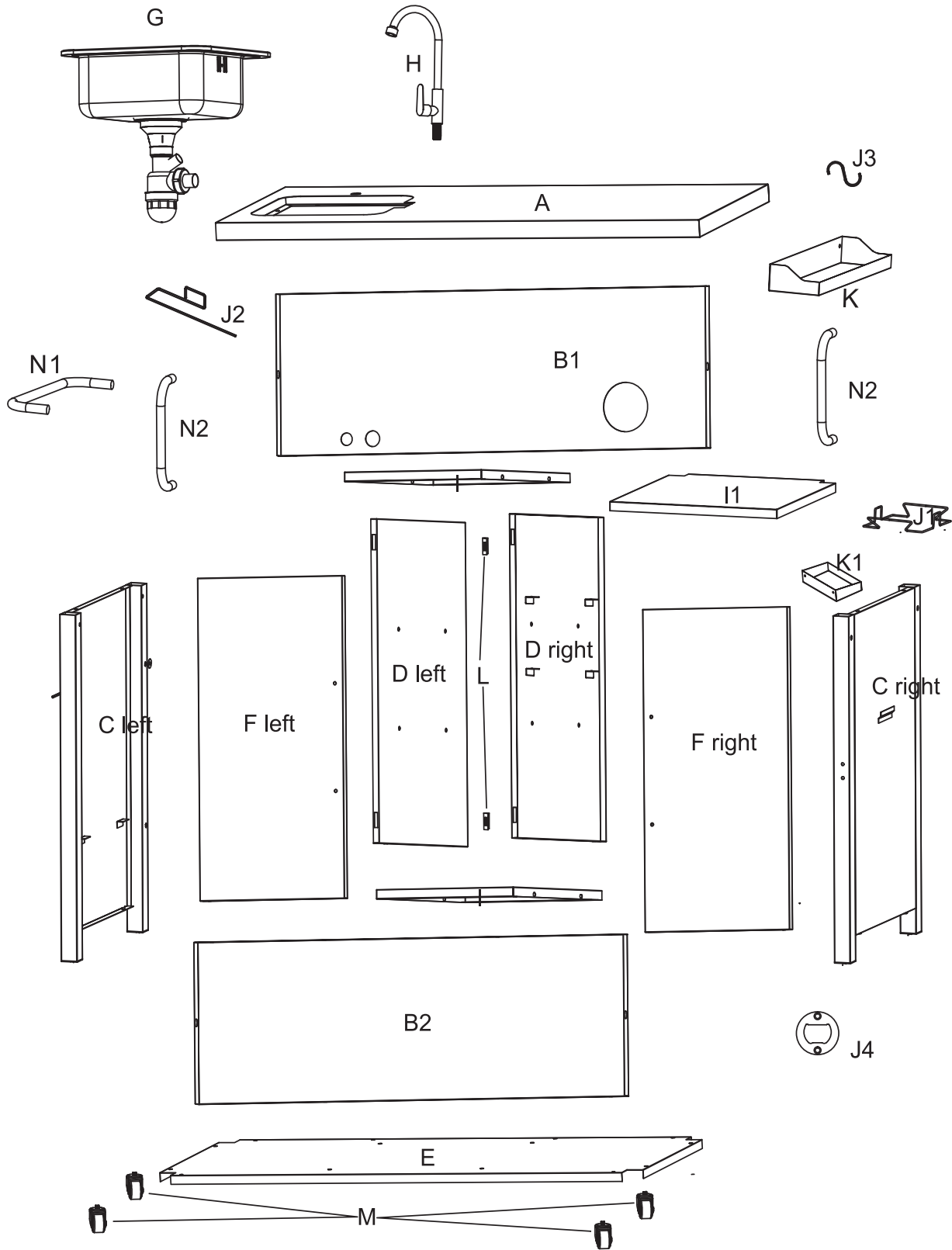

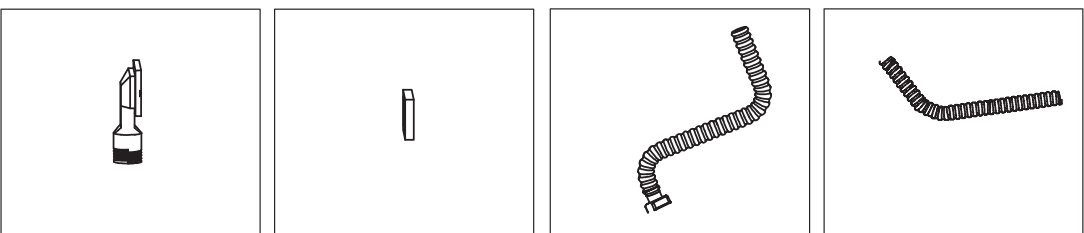
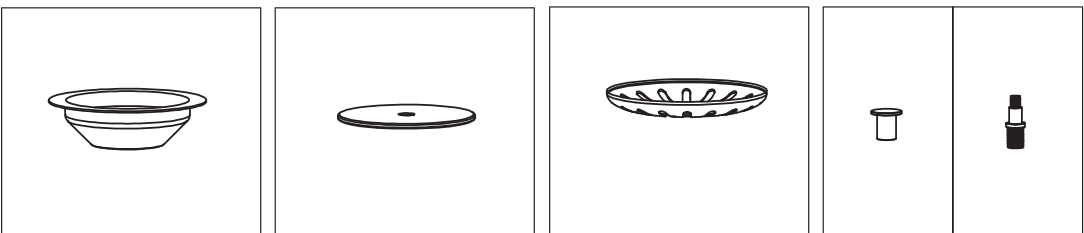
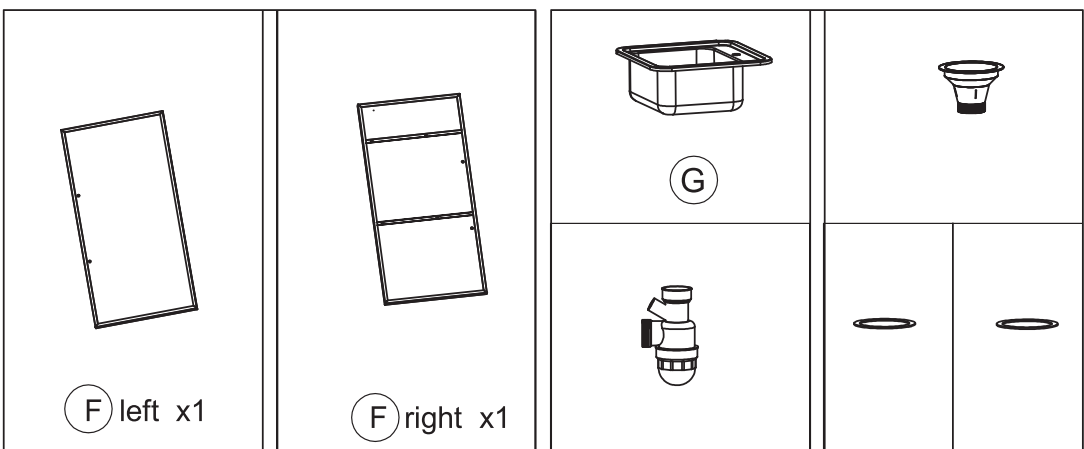
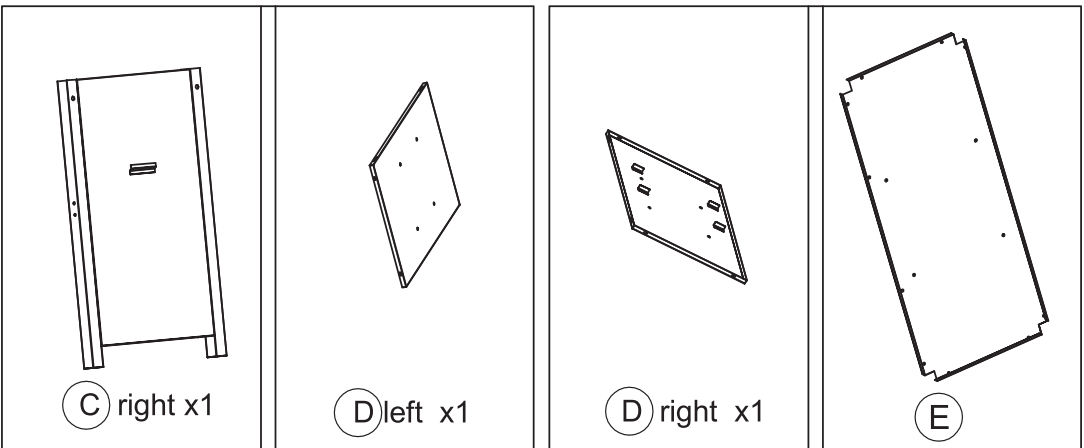
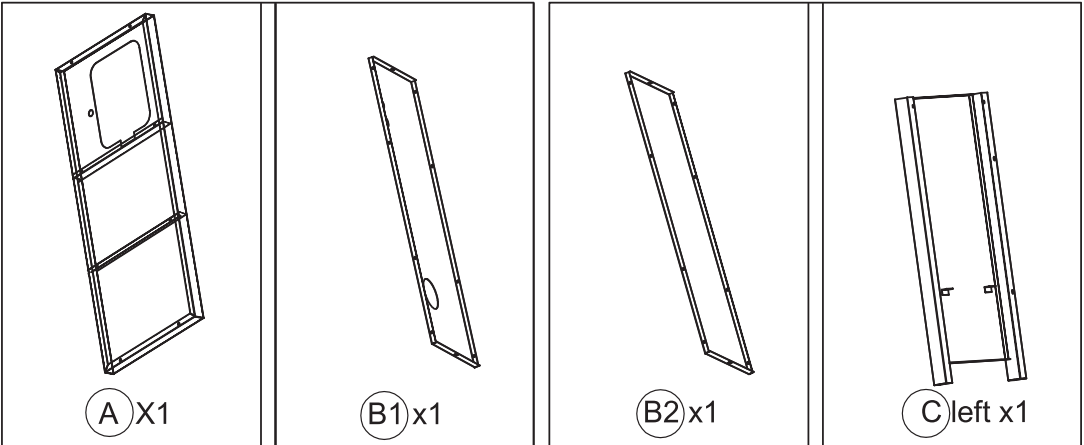

Assembly Instruction



Parts Lists

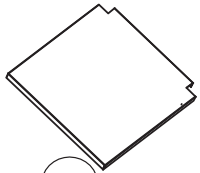
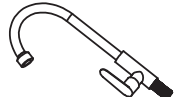

Parts Lists

 H1)x1	 H2)x1	 H3)x1	 H4)x1	 H5)x1	 I)x2
 I1)x1	 H				

Hardware

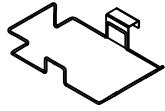

J1 x1



J2 x1



J3 x4



J4 x1

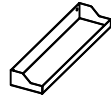

K x1



K1 x1



M x4



N1 x1



N2 x2



M6x10mm

1 x42



M6x15mm

2 x4



M6x50mm

3 x2



M4x25mm

4 x2



M6

5 x4



M6

6 x36



6mm

7 x1

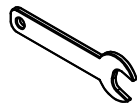

8 x1



M5

9 x4

Before installing the Grill Cart with Sink , you should prepare the following tools for installation:

Screwdriver

Allen wrench

Small wrench

Cordless drill

Assembly Instruction

<1>

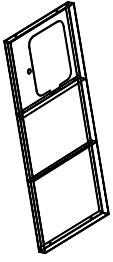

(A) x1

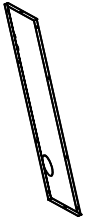

(B1) x1



M6x10mm

(1) x4



M6

(2) x4

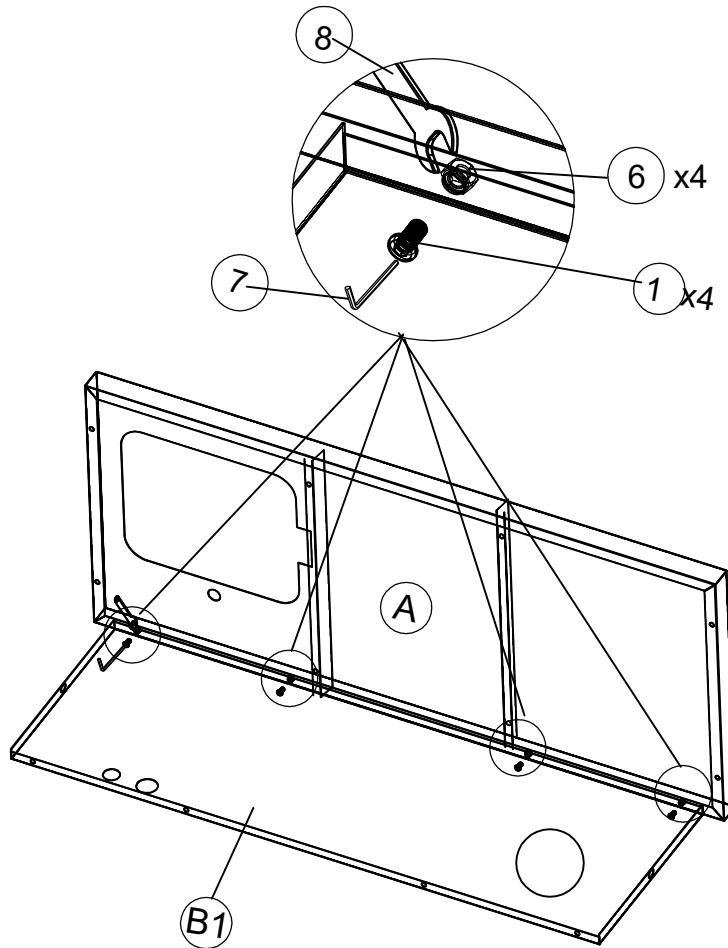

picture 1

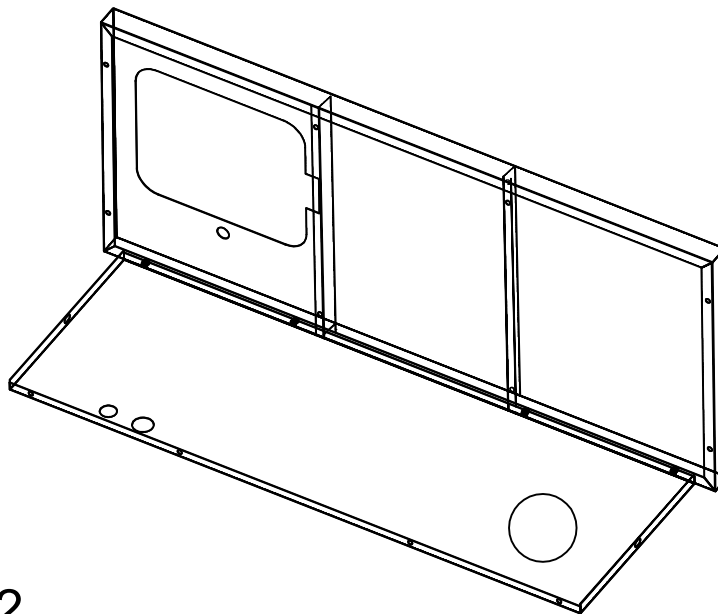

picture 2

Step 1: Install (A) and (B1) part

As shown in picture 1 and picture 2: First, put (A) and (B1) together, use screws (1) to pass through the holes in both (B1) and (A), connect (B1) to (A), connect them with the nuts (2), and then tighten them by the Allen wrench (7) and the Small wrench (8).

Note: All the corresponding hole positions and the screws and the nuts must be concentric.

Assembly Instruction

<2>

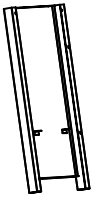

Ⓒ left x1

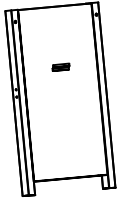

Ⓒ right x1



M6x10mm

① x6



M6

⑤ x2



M6

⑥ x4

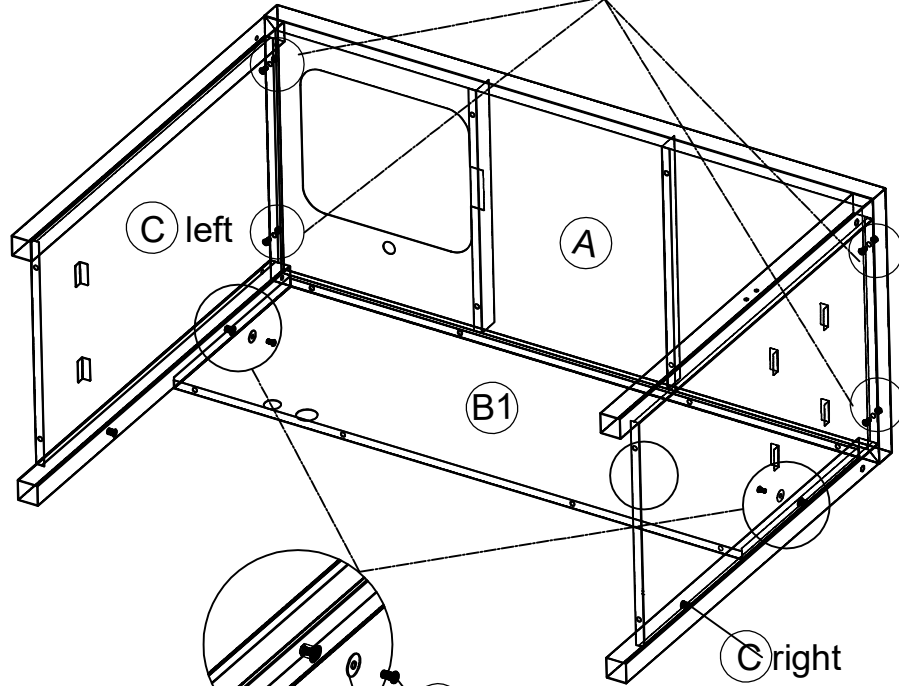
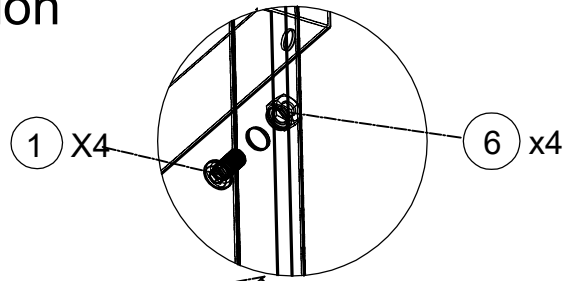

picture 3

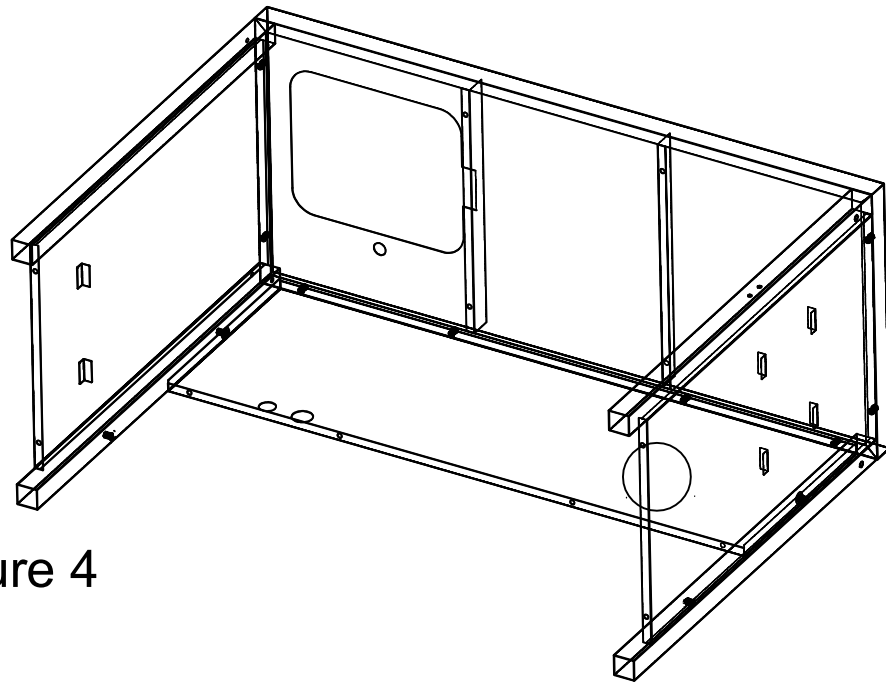
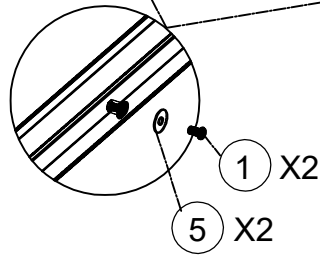

picture 4

Step 2 : Install Ⓒleft and Ⓒright

As shown in the picture 3 and picture 4: First ,connect Ⓒleft and Ⓒright together , Using the screws ① and the nuts ⑥. Then connect them and ① together ,using the screws ①. Tighten all the screws and the nuts.

Note:All the corresponding hole positions must be concentric.

Assembly Instruction

<3>

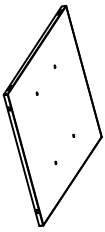

ⓓ left x1

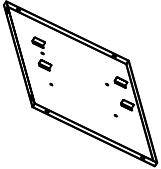

ⓓ right x1

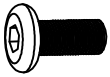

M6x10mm

① x4



M6

⑥ x4

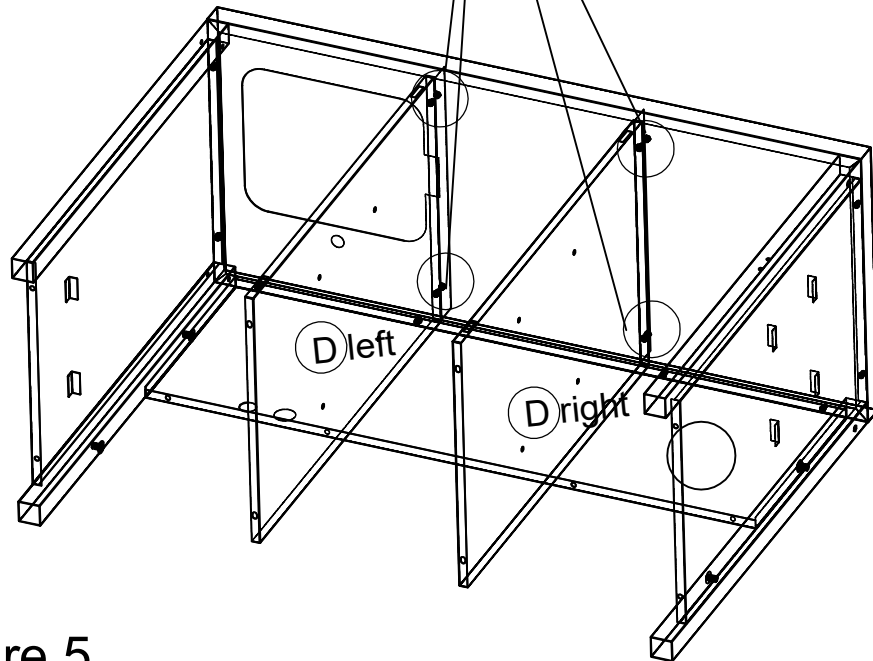
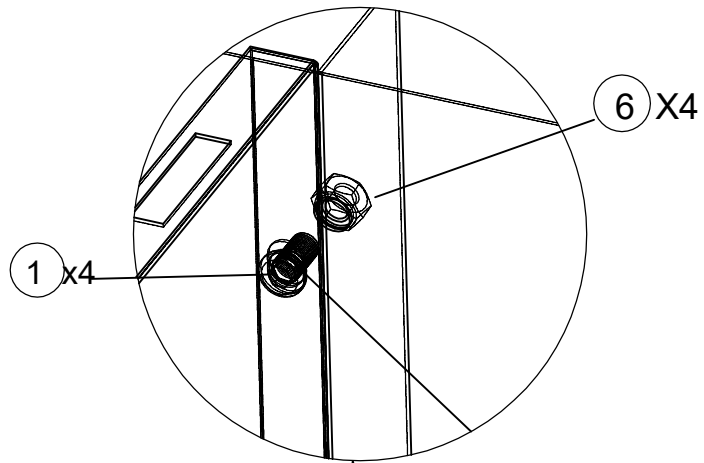

picture 5

Step 3 : Install ⓓleft and ⓓright

As shown in the picture 5:

Note: All the corresponding hole positions must be concentric.

Assembly Instruction

<4>

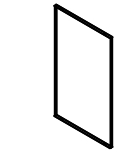
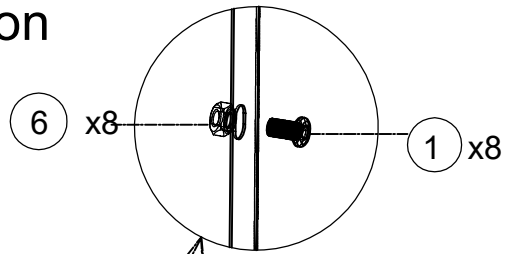

1 x2



1 x8



M6

2 x8

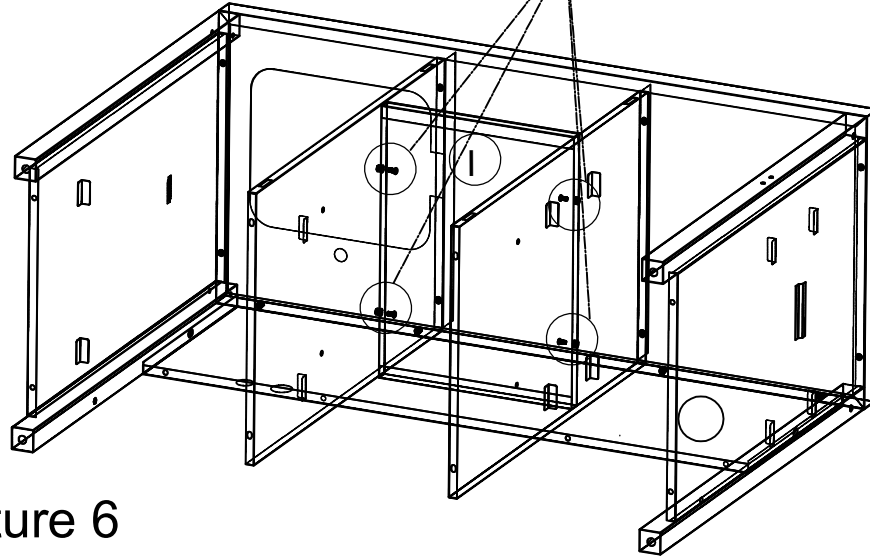

picture 6

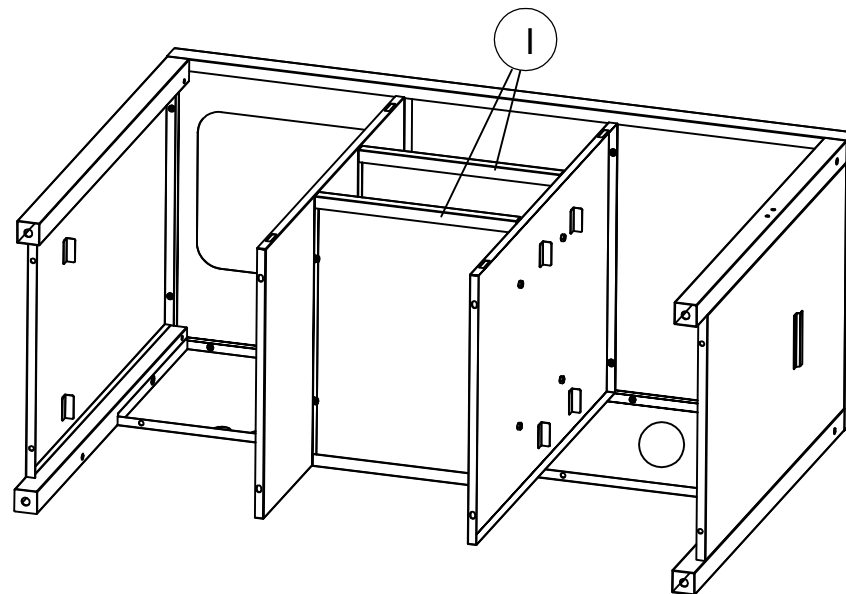

picture 7

Step 4 : Install ① X2

As shown in the picture 6 and picture 7:

Note: All the corresponding hole positions and the screws, nuts must be concentric.

Assembly Instruction



M6x10mm

1 X6



M6

5 X2



M6

6 X4

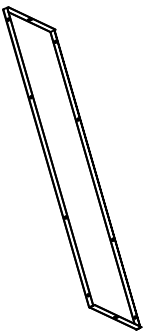

B2 X1

<5>

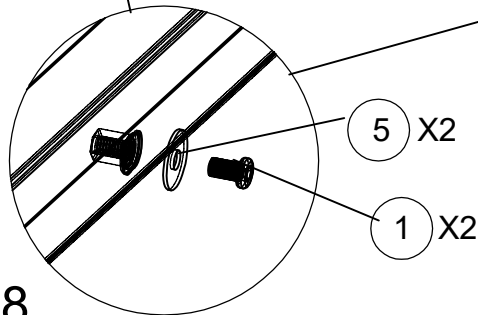
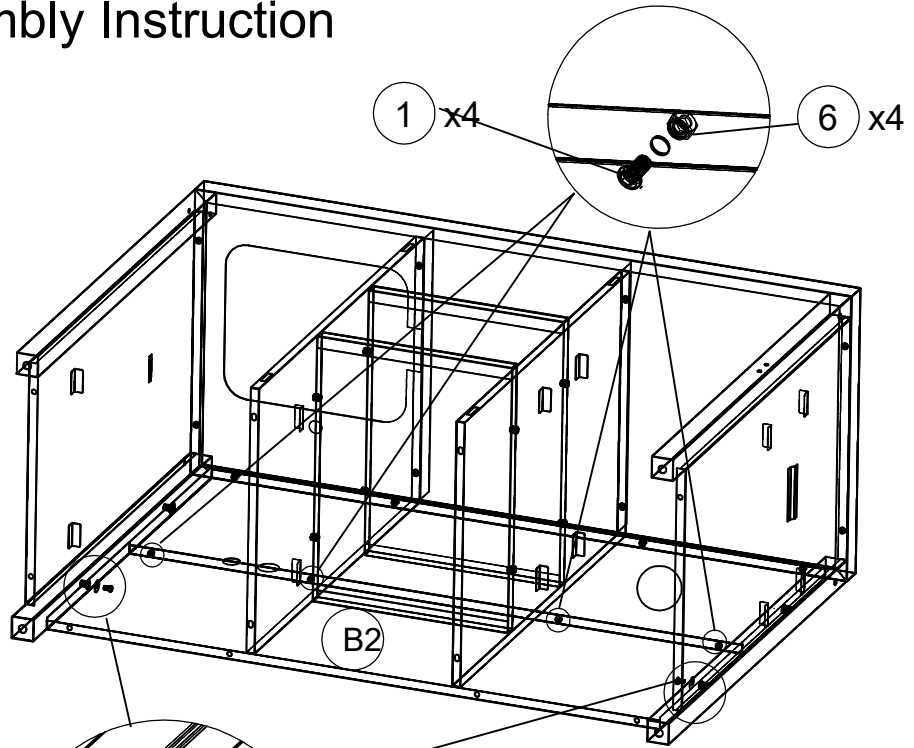

picture 8

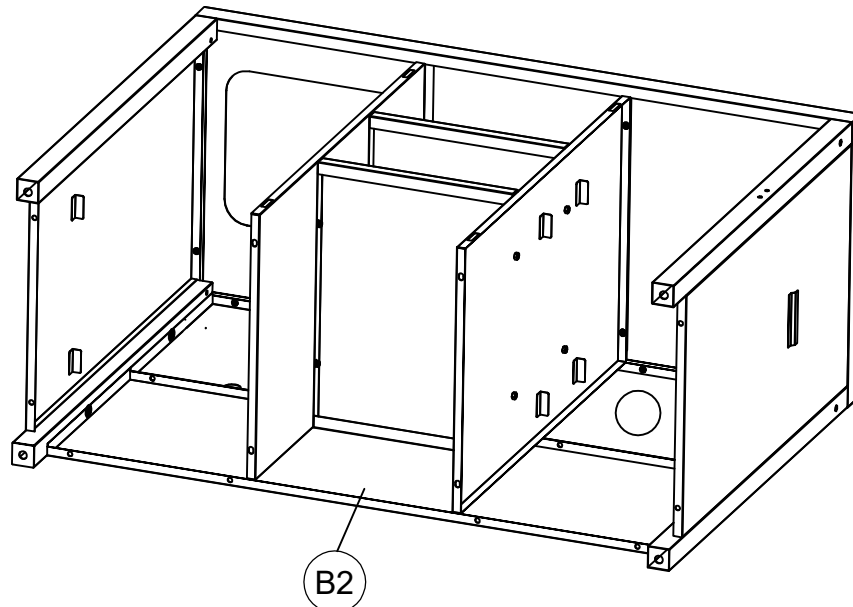

picture 9

Step 5: Install the (B2) part

As shown in the picture 8 and picture 9:

Note: All the corresponding hole positions must be concentric.

Assembly Instruction

<6>



M6x10mm

1 x12



M6

6 x12

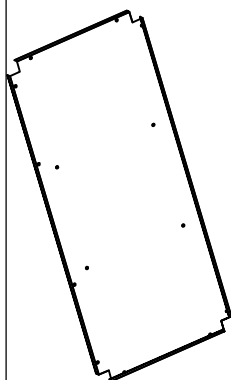

E X1

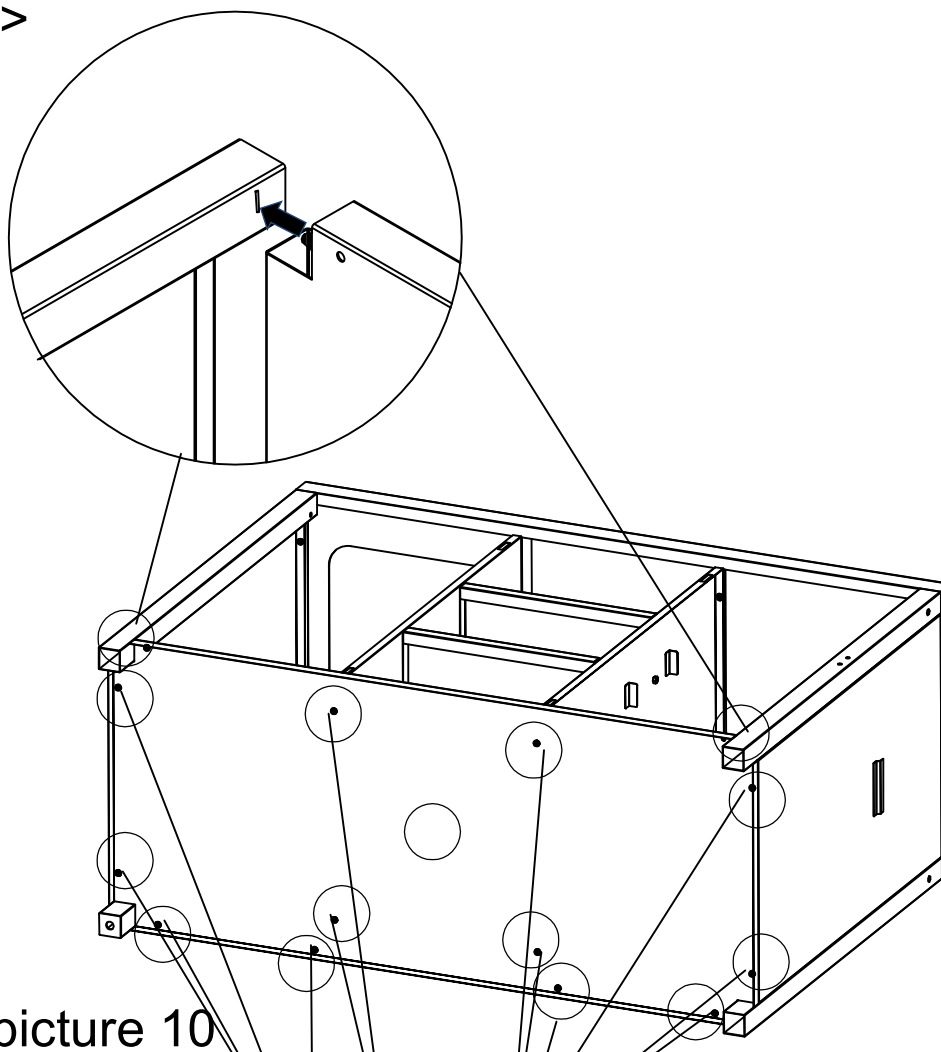

picture 10

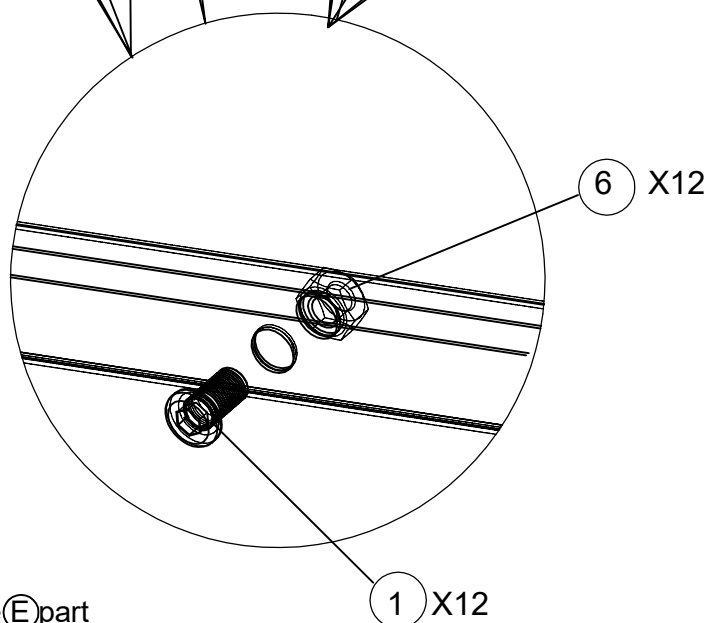

Step 6: Install the E part

As shown in the picture 10 :

Note: All the corresponding hole positions must be concentric.

Assembly Instruction

<7>



M x4

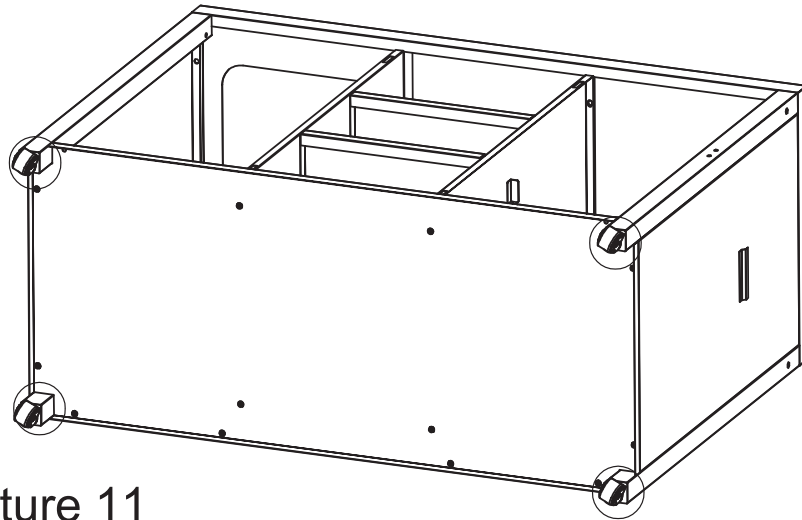

picture 11

Step 7: Install the universal wheels (M)

As shown in the picture 4 to 5: Put the mobile folding table upside down, then install the universal wheels (M) on each of the four legs. make the screws of the universal wheels and the holes on the legs are concentric. and then tighten all the screws of the universal wheels.

Assembly Instruction

<8>

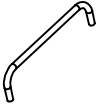

(N1) x1



M6x50mm

(3) x2

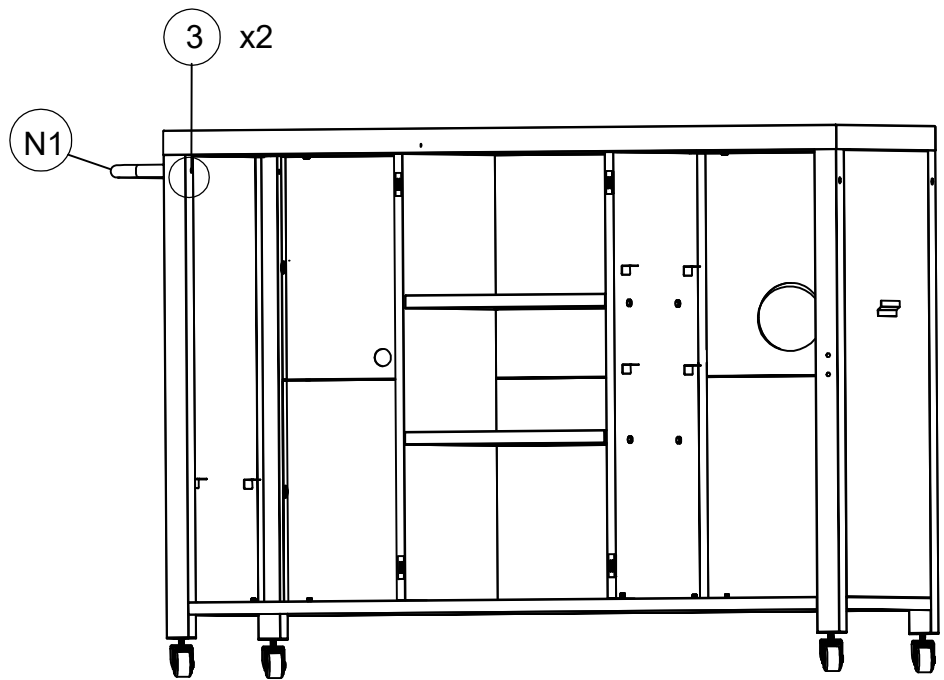

picture12

Assembly Instruction

<9>

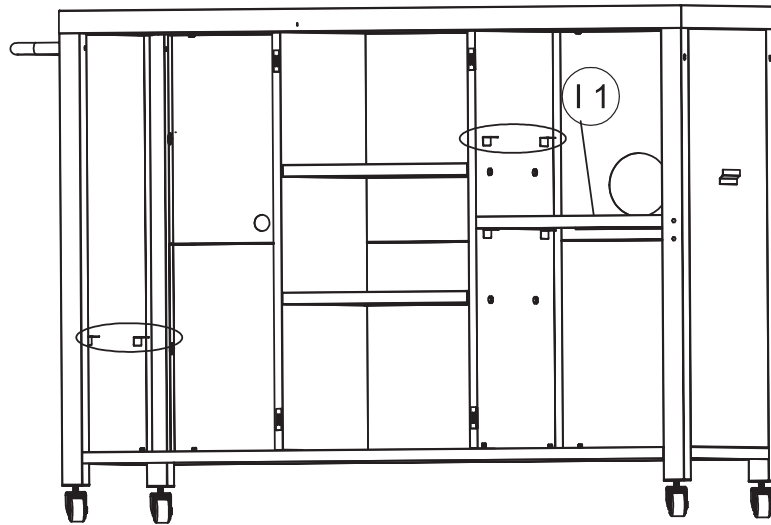
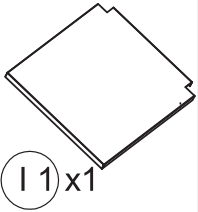

picture 13

The shelf board (11) can be interchanged both left-right and top-bottom

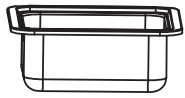

Gx1



Assembly Instruction

<10>

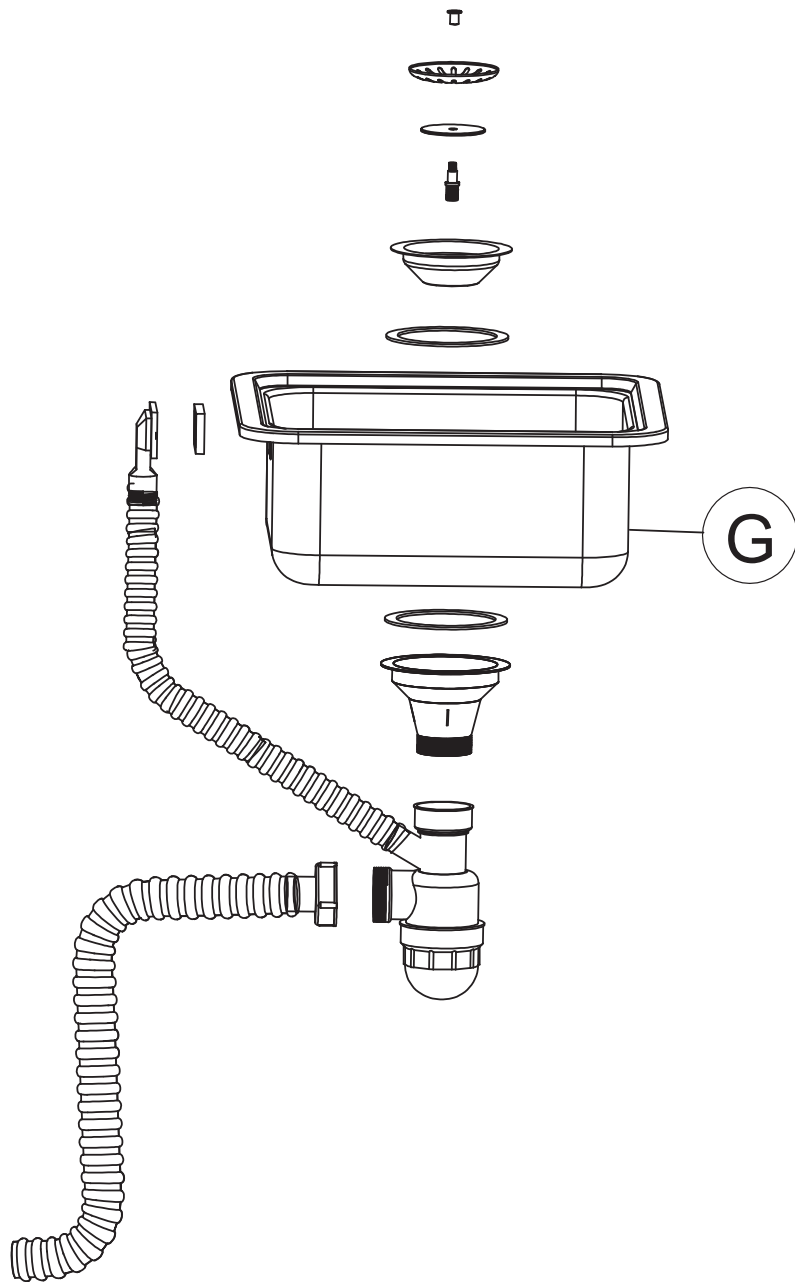

picture 14

Step 10: Install the Washbasin components
Please refer to the exploded view diagram instructions included in the packaging for assembly.

Assembly Instruction

<11>

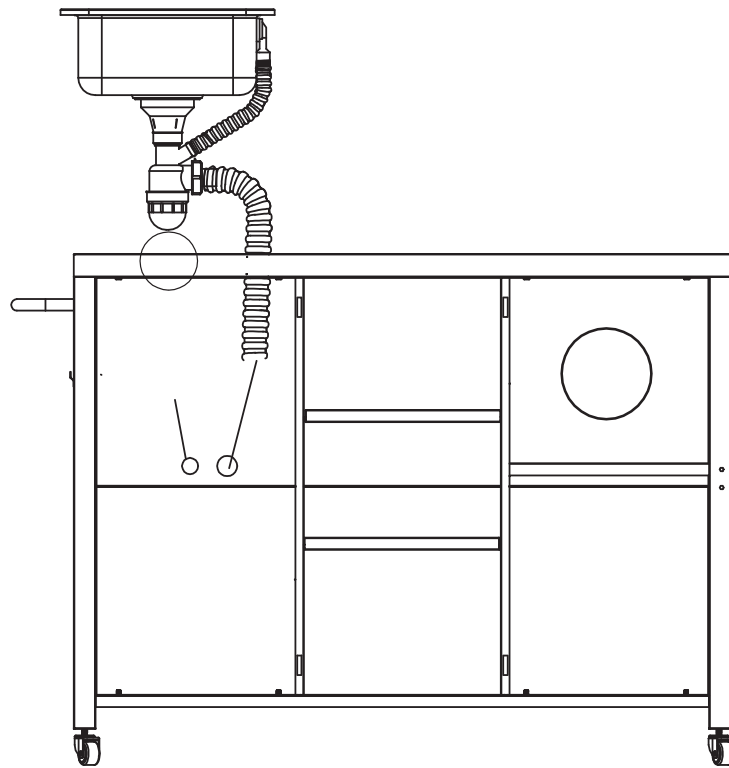

picture 15

Step 11: Install the Washbasin

As shown in the picture15 and picture 18 : You must tighten the nut G8 and the nut G7
Note:All the corresponding hole positions must be concentric.

15

Assembly Instruction

<12>



H x1



H1 x1



H2 x1



H3 x1



H4 x1

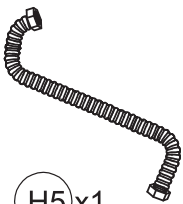

H5 x1

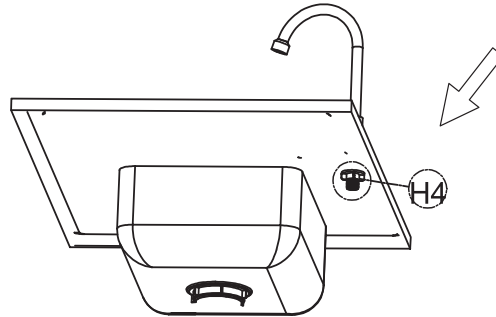
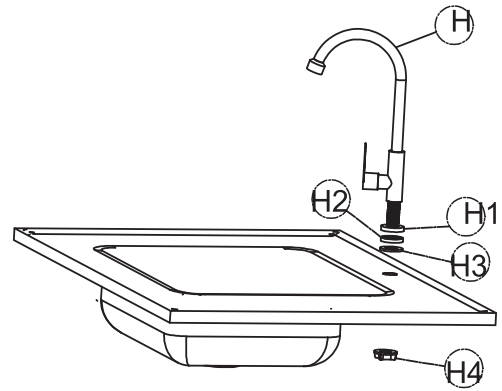

picture 16

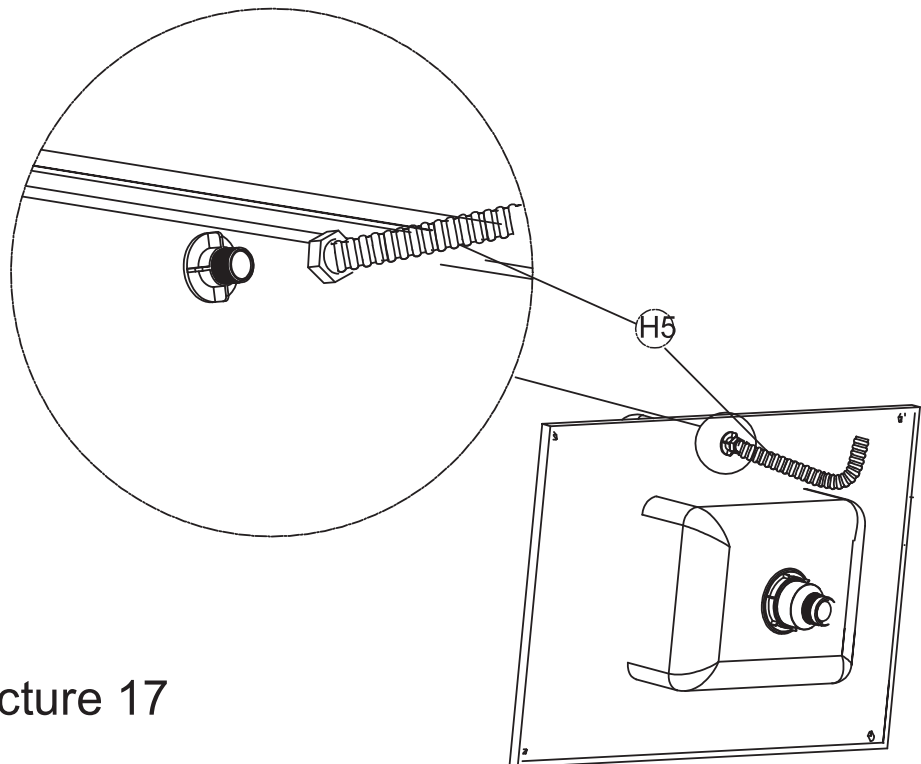

picture 17

16

Step 12: Install the Faucet components
As shown in the picture 16 to picture 17: You must tighten the nut H5.
Note: All the corresponding hole positions must be concentric.

Assembly Instruction

<13>

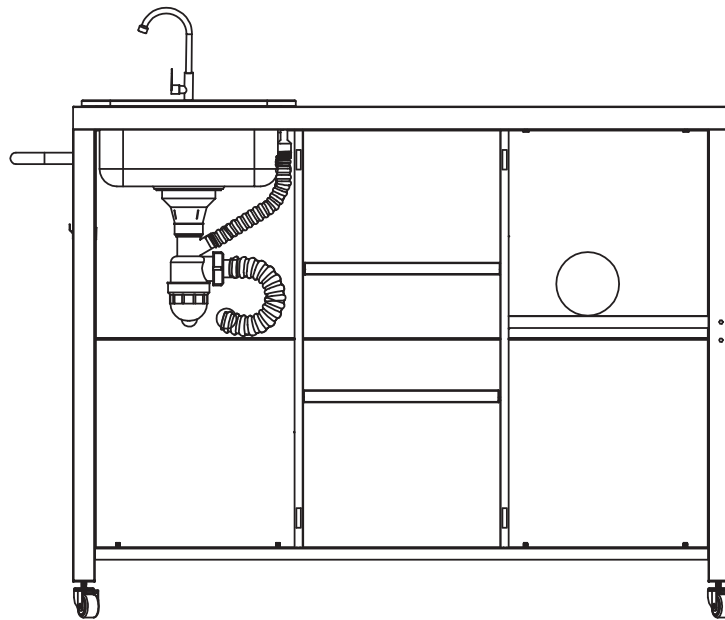

picture 19

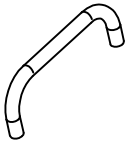

N2 x2

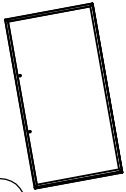

F left x1

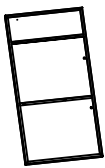

F right x1



M6x15mm

3 x4

Assembly Instruction

<14>

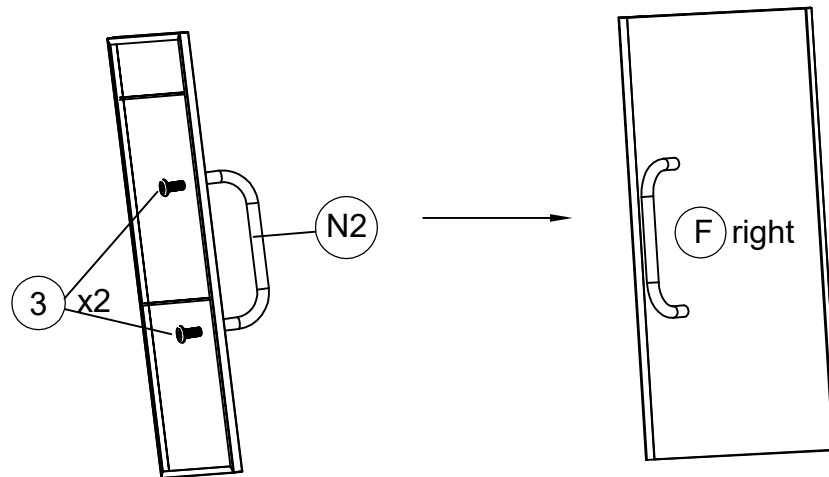
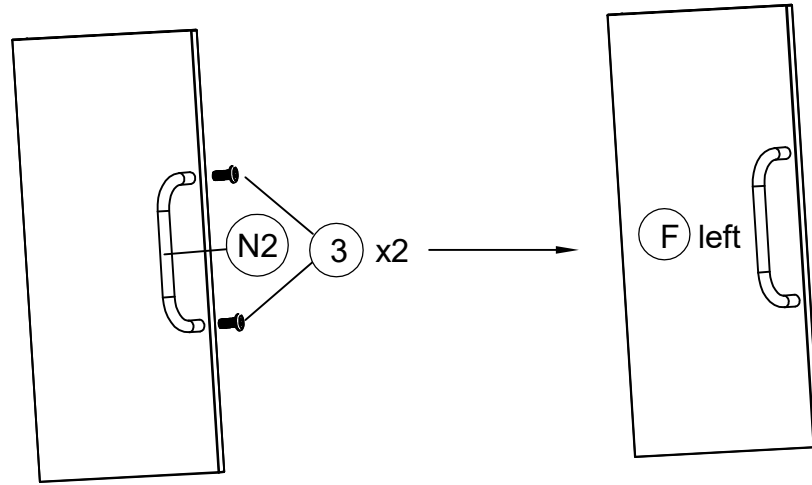

picture 20

Step 14 : Install the door handle (N2)

As shown in the picture 20:

Note: All the corresponding hole positions must be concentric.

Assembly Instruction

<15>



(K1) x1



M6x10mm

(1) x 2

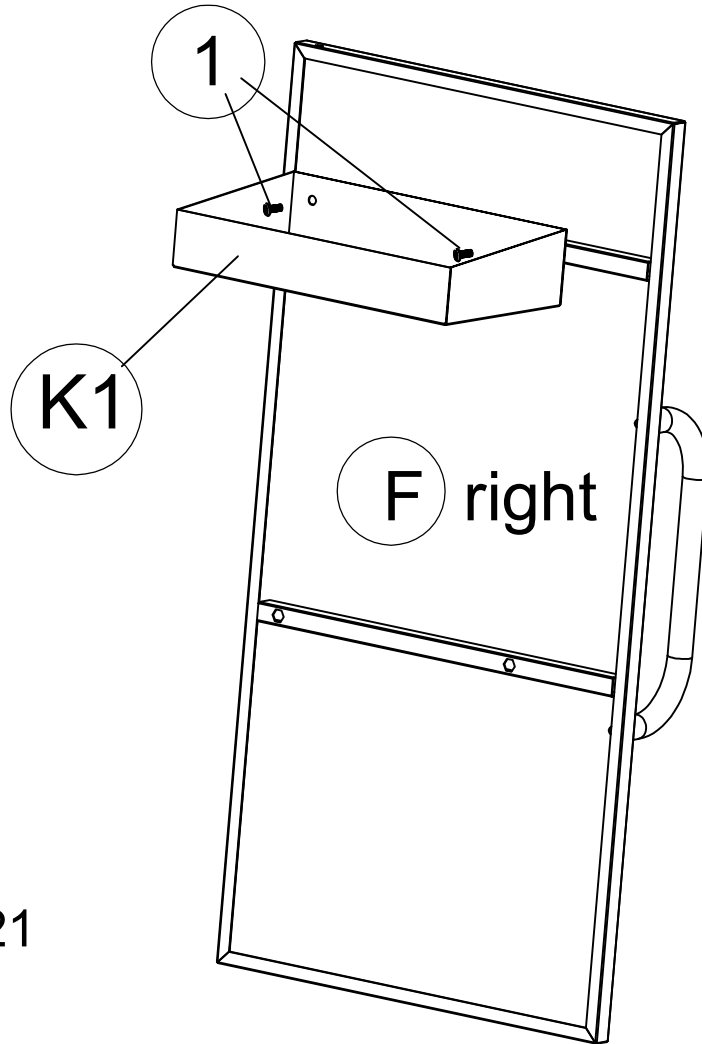

picture 21

Step 15 : Install the (K1) part
As shown in the picture 21:

Note: All the corresponding hole positions must be concentric.

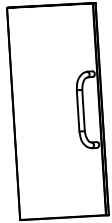

Assembly Instruction

<16>

F left x1

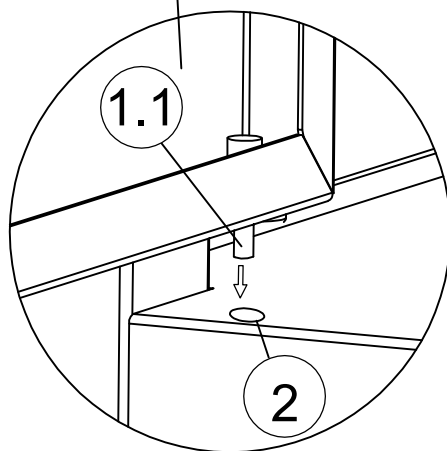
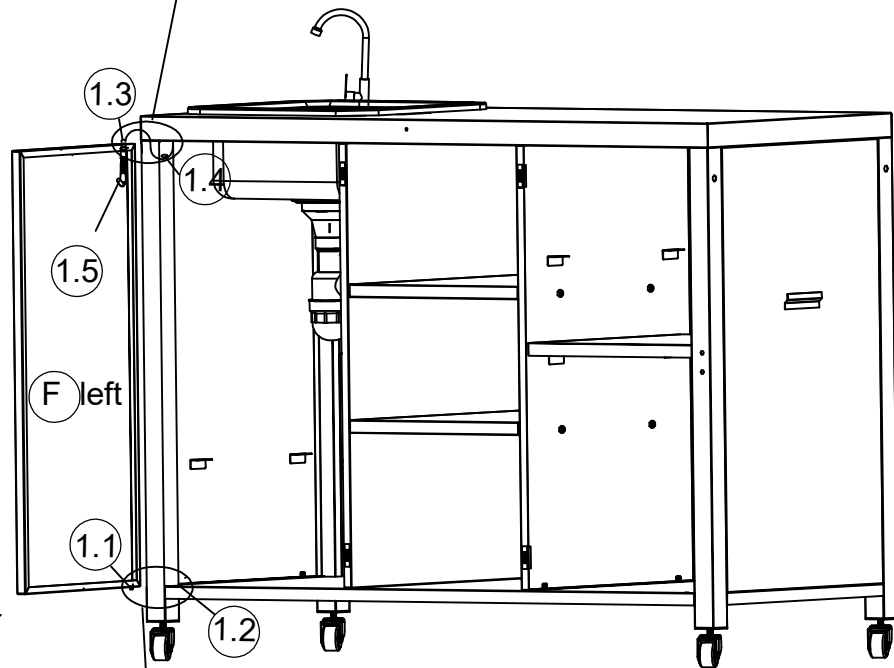
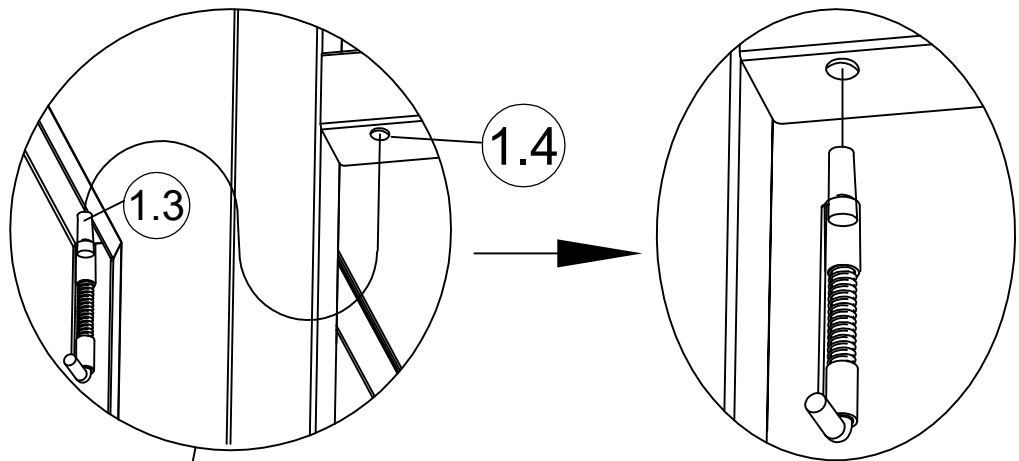

picture 22

Step 16 : Install the doors

As shown in the picture 22: First , install the left door ,Make 1.1 target 1.2,as the picture 16,then pull the plug 1.5 down as the picture 17,and make 1.3 target 1.4 ,thenre-lease your hand. Using the same method ,you can install the F right door.

Note:All the corresponding hole positions must be concentric.

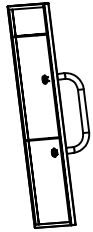

Fright x1

Assembly Instruction

<17>

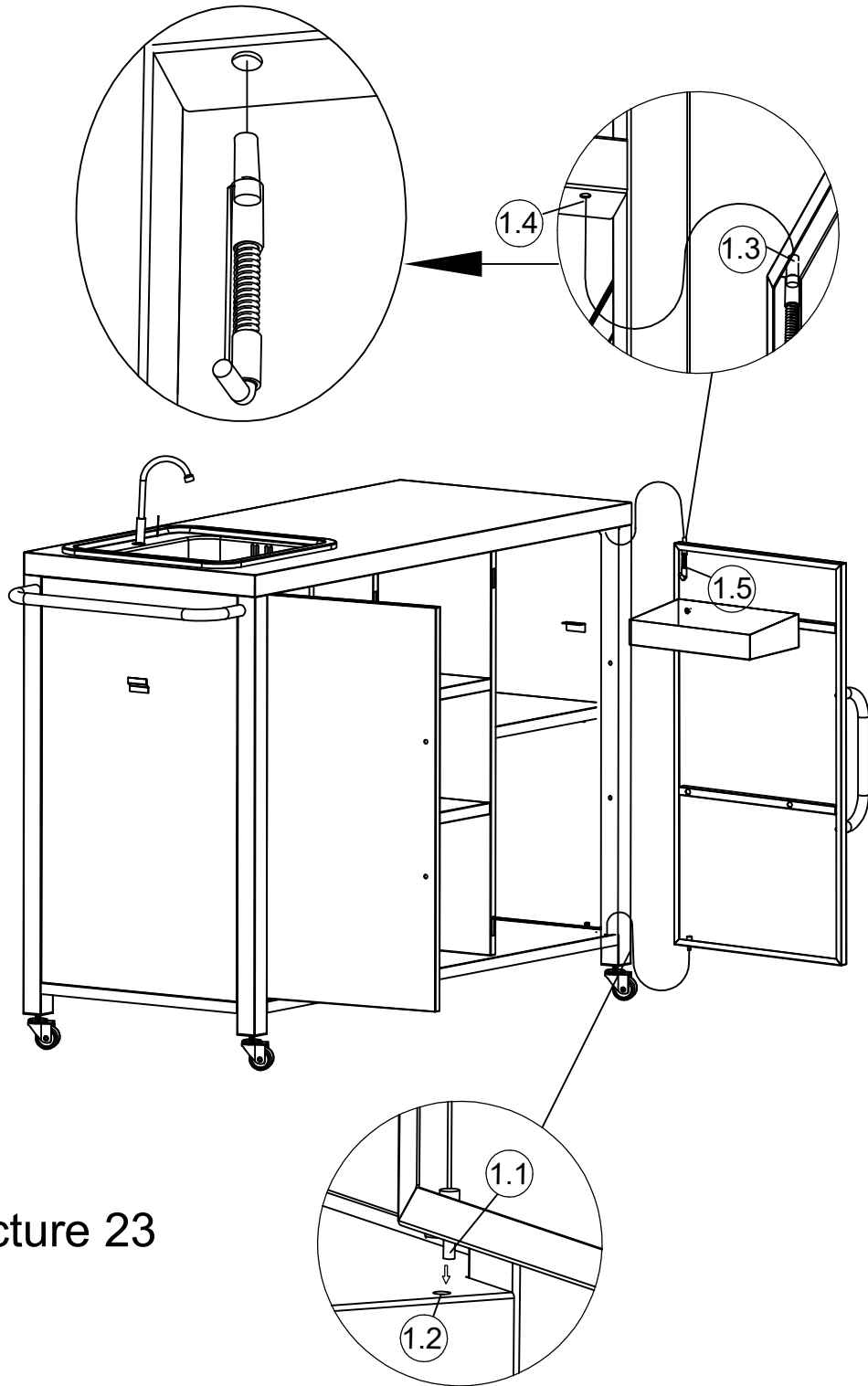

picture 23

Step 17 : Install the doors

As shown in the picture 23: First , install the left door ,Make 1.1 target 1.2,as the picture 16,then pull the plug 1.5 down as the picture 17,and make 1.3 target 1.4 ,then release your hand. Using the same method ,you can install the Fright door.

Note:All the corresponding hole positions must be concentric.

Assembly Instruction

<18>

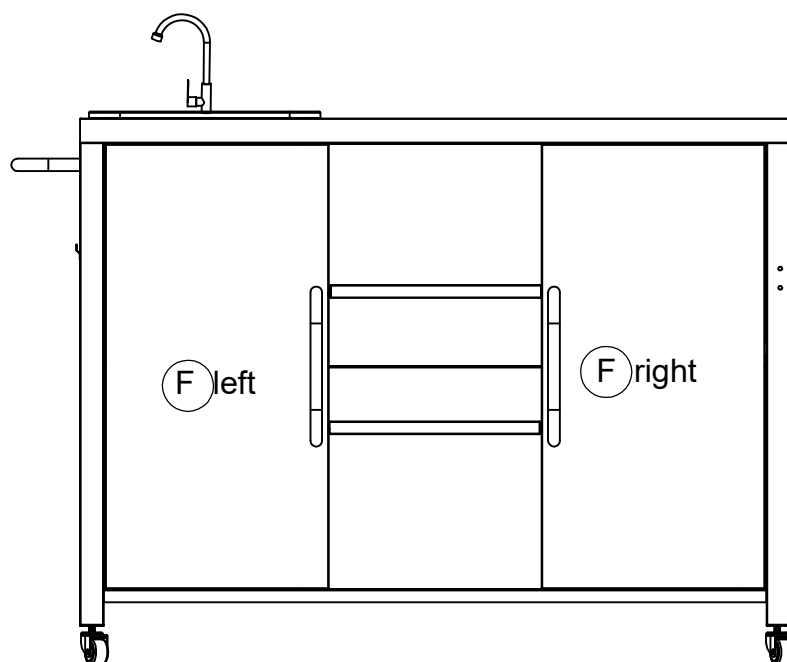

picture 24

Assembly Instruction

<19>



J4 x1



M4x25mm

4 x2



9 x4

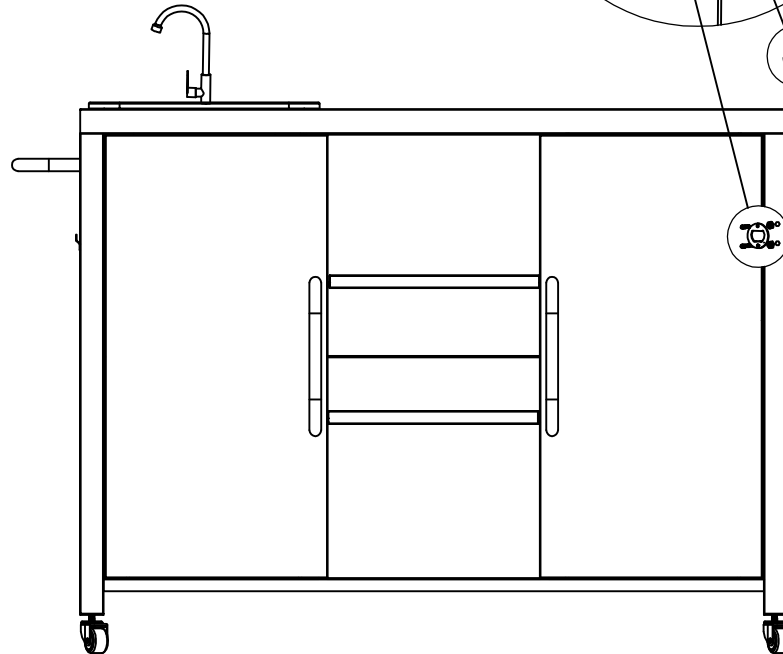
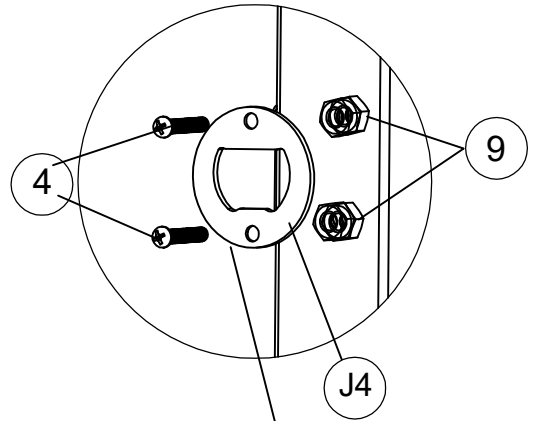

picture 25

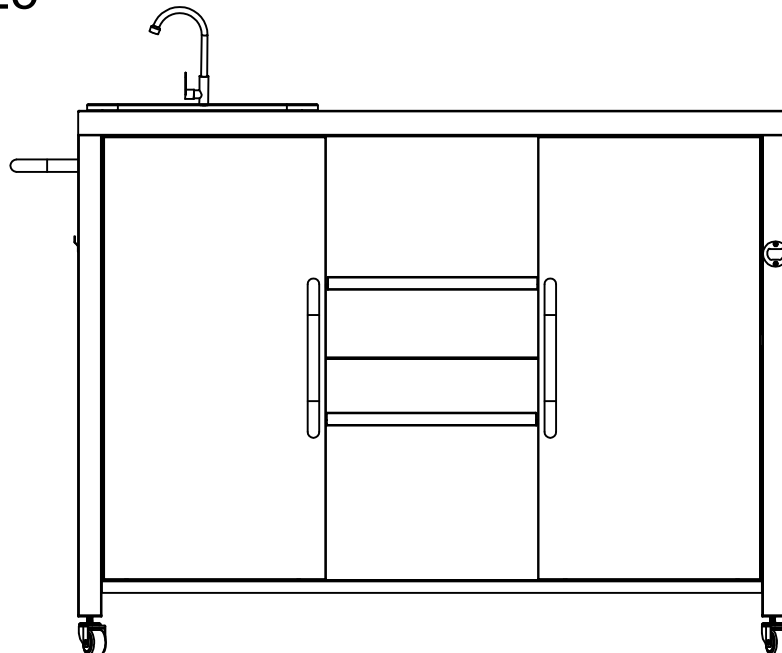

picture 26

Step 19 : Install J4

As shown in the picture 25 to picture 26: Put 9 between J4 ,then connect them by the screws 4

Assembly Instruction

<20>

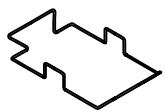

ⓐ x1



ⓑ x4



M6x10mm

ⓓ x2

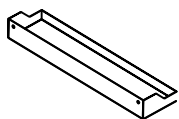

ⓔ x1

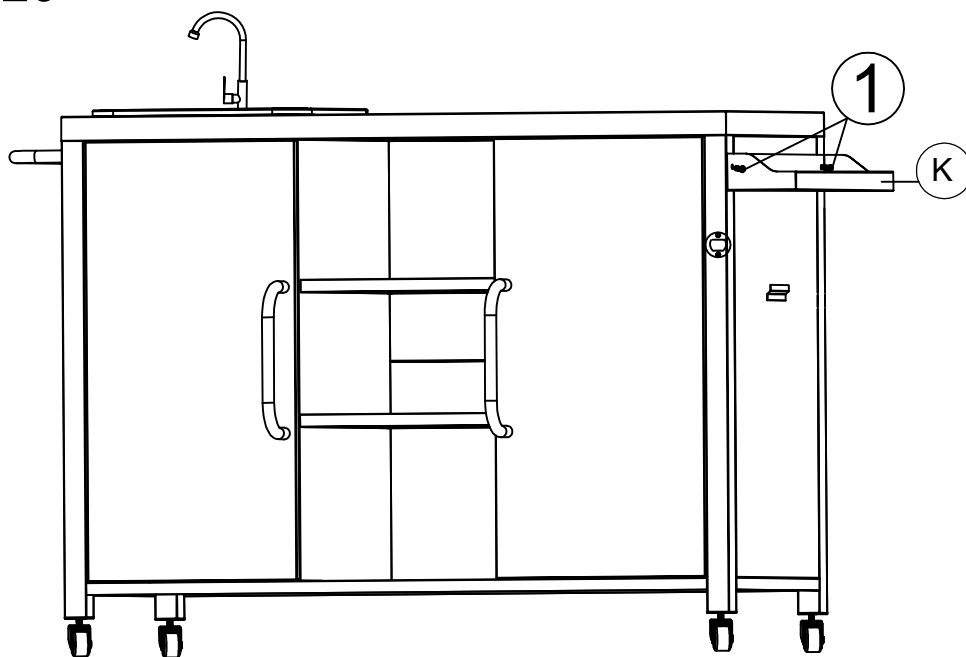

picture 27

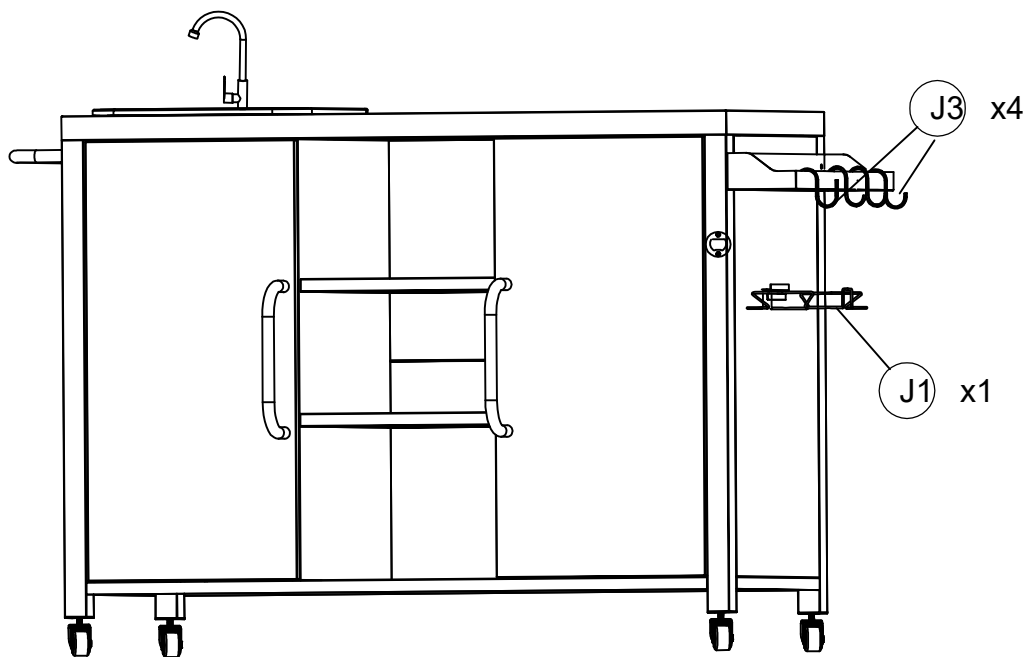

picture 28

Step 20 : Install ⓔ and ⓐ and ⓑ
As shown in the picture 27 and 28:

Assembly Instruction

<21>



J2 x1

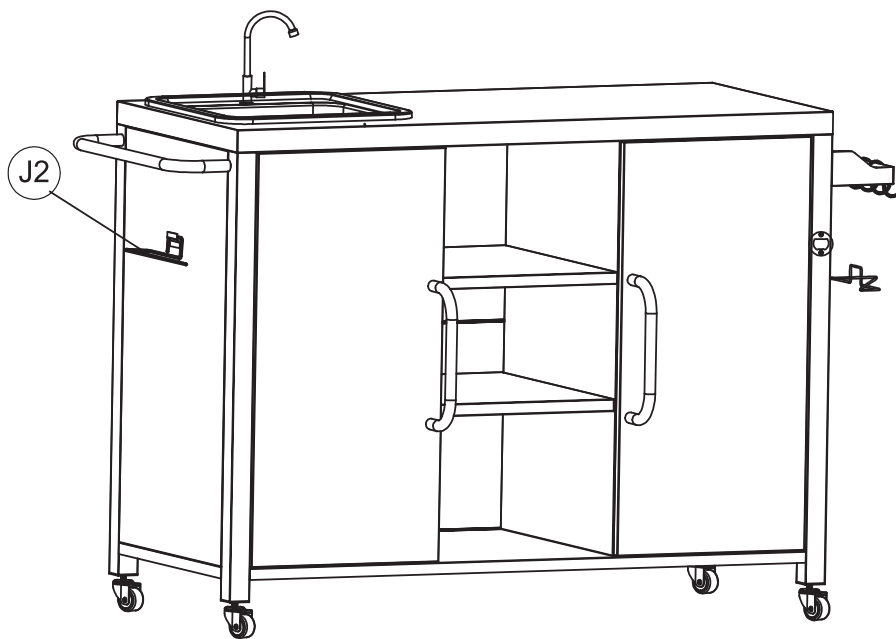

picture 29

Step 21: Install J2
As shown in the picture 29:

Assembly Instruction

<22>

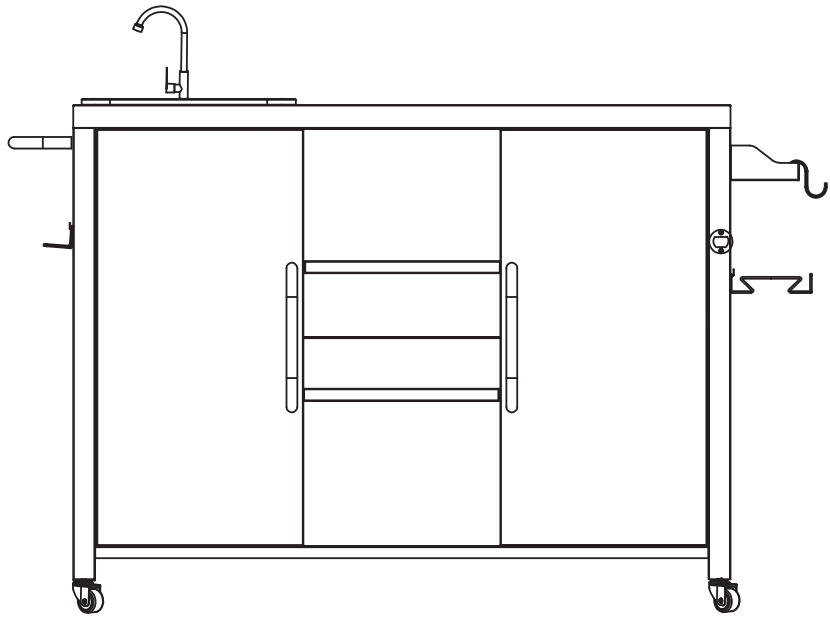

Please remove the desktop protective film before using the product.

Questions & Answers about Proposition 65

- What is Proposition 65?

Proposition 65 requires businesses to provide warnings to Californians about significant exposures to chemicals that cause cancer, birth defects or other reproductive harm. These chemicals can be in the products that Californians purchase, in their homes or workplaces, or that are released into the environment. By requiring that this information be provided, Proposition 65 enables Californians to make informed decisions about their exposures to these chemicals.

Proposition 65 also prohibits California businesses from knowingly discharging significant amounts of listed chemicals into sources of drinking water.

Proposition 65 requires California to publish a list of chemicals known to cause cancer, birth defects or other reproductive harm. This list, which must be updated at least once a year, has grown to include approximately 900 chemicals since it was first published in 1987.

- What types of chemicals are on the Proposition 65 list?

The list contains a wide range of naturally occurring and synthetic chemicals that include additives or ingredients in pesticides, common household products, food, drugs, dyes, or solvents. Listed chemicals may also be used in manufacturing and construction, or they may be byproducts of chemical processes, such as motor vehicle exhaust.

- What does a warning mean?

If a warning is placed on a product label or posted or distributed at a workplace, a business, or in rental housing, the business issuing the warning is aware or believes that it is exposing individuals to one or more listed chemicals.

By law, a warning must be given for listed chemicals unless the exposure is low enough to pose no significant risk of cancer or is significantly below levels observed to cause birth defects or other reproductive harm.

- Where can I get more information on Proposition 65?

If you have specific questions on the administration or implementation of Proposition 65, you can contact OEHHA's Proposition 65 program at P65.Questions@oehha.ca.gov, or by phone at (916) 445-6900.