

ASSEMBLY INSTRUCTIONS

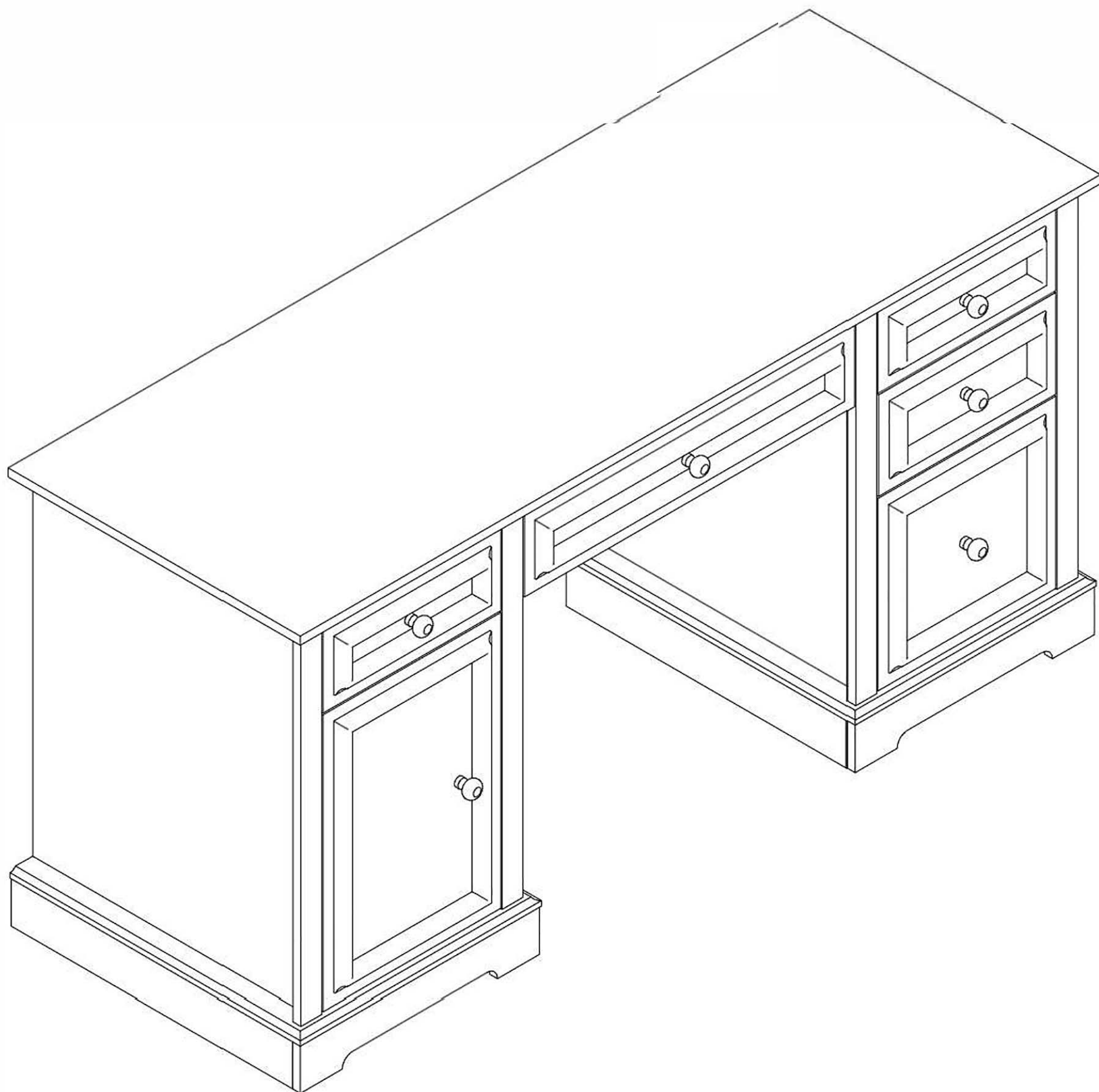

Thank you for purchasing our product!

Please refer and use this assembly instruction to assemble the product.

Contact our customer service department in case there are any missing or damage parts or hardware. Please also tell us your "Order ID"

ASSEMBLY PREPARATION:

1. Remove all packaging materials, staples and packing straps from the carton.
2. Refer to Parts List and Hardware List and ensure they are correct before assembly. Contact customer service for missing parts.
3. Place all wooden parts on a clean, flat and soft surface (e.g. carpet or rug) to prevent parts from getting scratched.

SAFETY PRECAUTION:

1. Keep all hardware parts out of reach of children.
2. Dispose plastic packaging material immediately to avoid any risk of suffocation to children and animals..

TIPS FOR ASSEMBLY:

1. Allow ample room for assembly and in close proximity to where product will be placed.
2. Assemble the product on a surface that does not scratch or damage the exterior gloss and finish of the furniture.
3. Identify all of the parts, hardware and quantities required for each step.
4. During assembly, do not over-tighten any fittings as this may cause damage.
5. DO NOT USE POWER TOOLS TO ASSEMBLE THIS PRODUCT.
6. Always place the product on a flat, level surface.
7. Do not sit or stand on the partially assembled product; only use the product for which it is intended.

CARE AND MAINTENANCE:

- Use a slightly damp cloth to clean the product. Do not use bleach or abrasive cleaning material.
- Check all the fittings periodically and re-tighten as necessary. Do not use the product if any of the parts is damaged or broken.
- Never allow any kind of liquid to remain on your furniture. Absorption can cause wood to warp or delaminate.
- Do not place hot items (e.g. hot drinks) directly onto the wood surface.





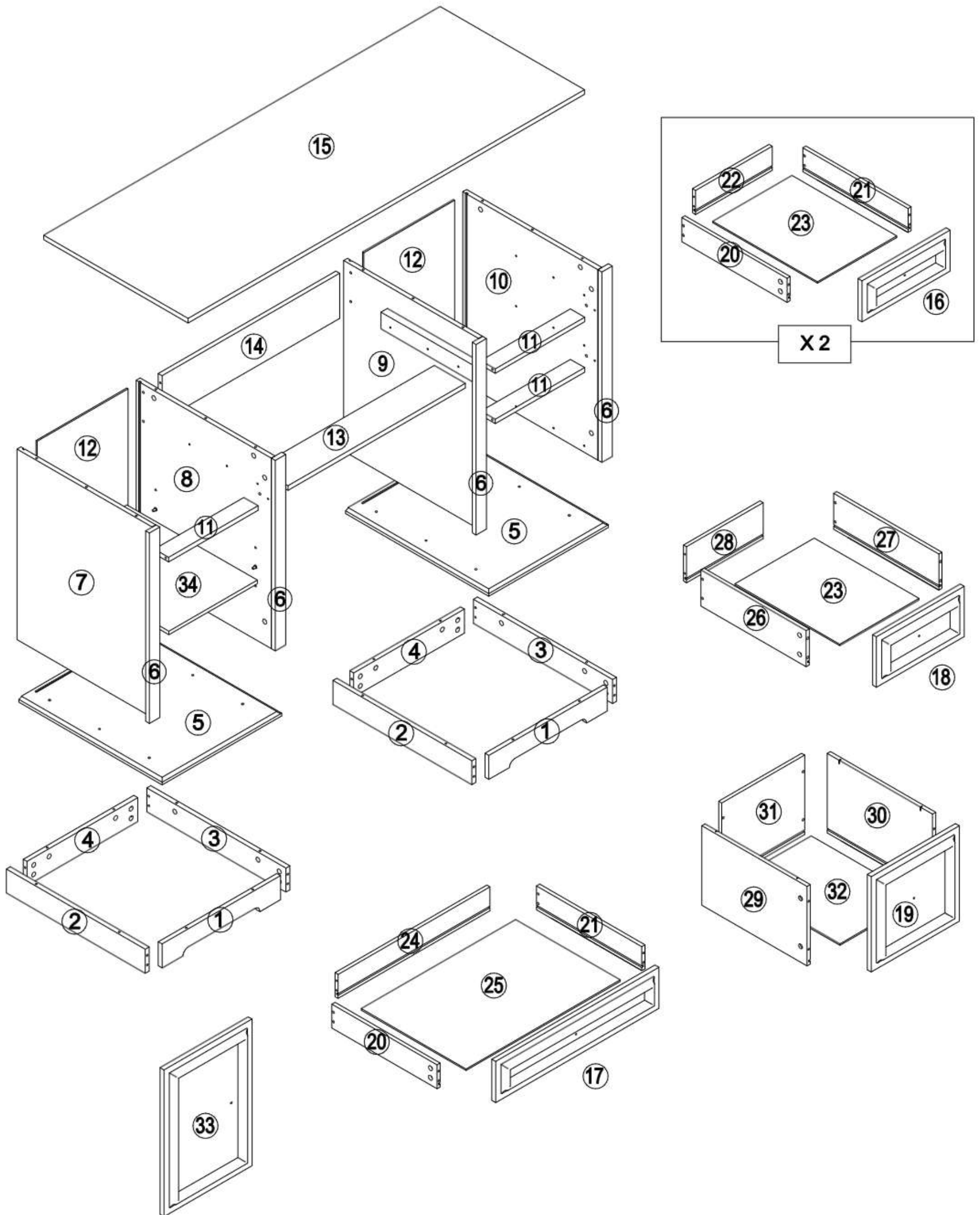



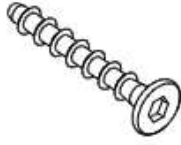
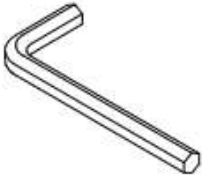

Part List

Please check if all the pieces listed bellow are received

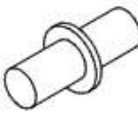
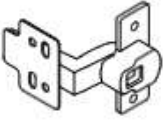

Hardware List

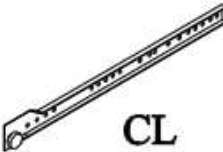
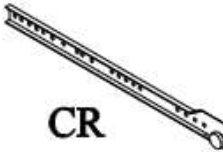
Please check if all the piece listed bellow are received

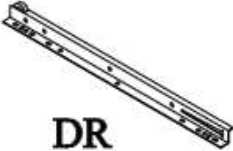
<p>A</p>  <p>Cam Bolt Ø6.5 x 33mm Qty: 81</p>	<p>B</p>  <p>Cam Lock Ø15 x 9.5mm Qty: 81</p>	<p>C</p>  <p>Wood Dowel Ø8 x 30mm Qty: 22</p>	<p>D</p>  <p>Screw Ø6*38mm Qty: 32</p>
<p>E</p>  <p>Qty: 1</p>	<p>F</p>  <p>Knop Qty: 6</p>	<p>G</p>  <p>Bolt M4x15mm Qty: 6</p>	<p>H</p>  <p>Shelf support Qty: 4</p>
<p>I</p>  <p>Hinge Qty: 2</p>	<p>J</p>  <p>Screw Ø3*12mm Qty: 72</p>	<p>K</p>  <p>Plastic wedge Qty: 8</p>	<p>L</p>  <p>Screw Ø3*16mm Qty: 8</p>
<p>M</p>  <p>File support Qty: 2</p>	<p>N</p>  <p>CL Qty: 5</p>	<p>O</p>  <p>CR Qty: 5</p>	<p>P</p>  <p>DL Qty: 5</p>
<p>Q</p>  <p>DR Qty: 5</p>			

ASSEMBLY
REQUIREMENTS

3 Hours
Assembly Time
(Approximate)

2 -Person Assembly



Tools Required (Not Provided):

Phillips Screwdriver  ⊕

Flat Head Screwdriver  ⊖

Step 1

I. Screw in cam-bolt (A) into the designated holes on panel (1,2,3,5).

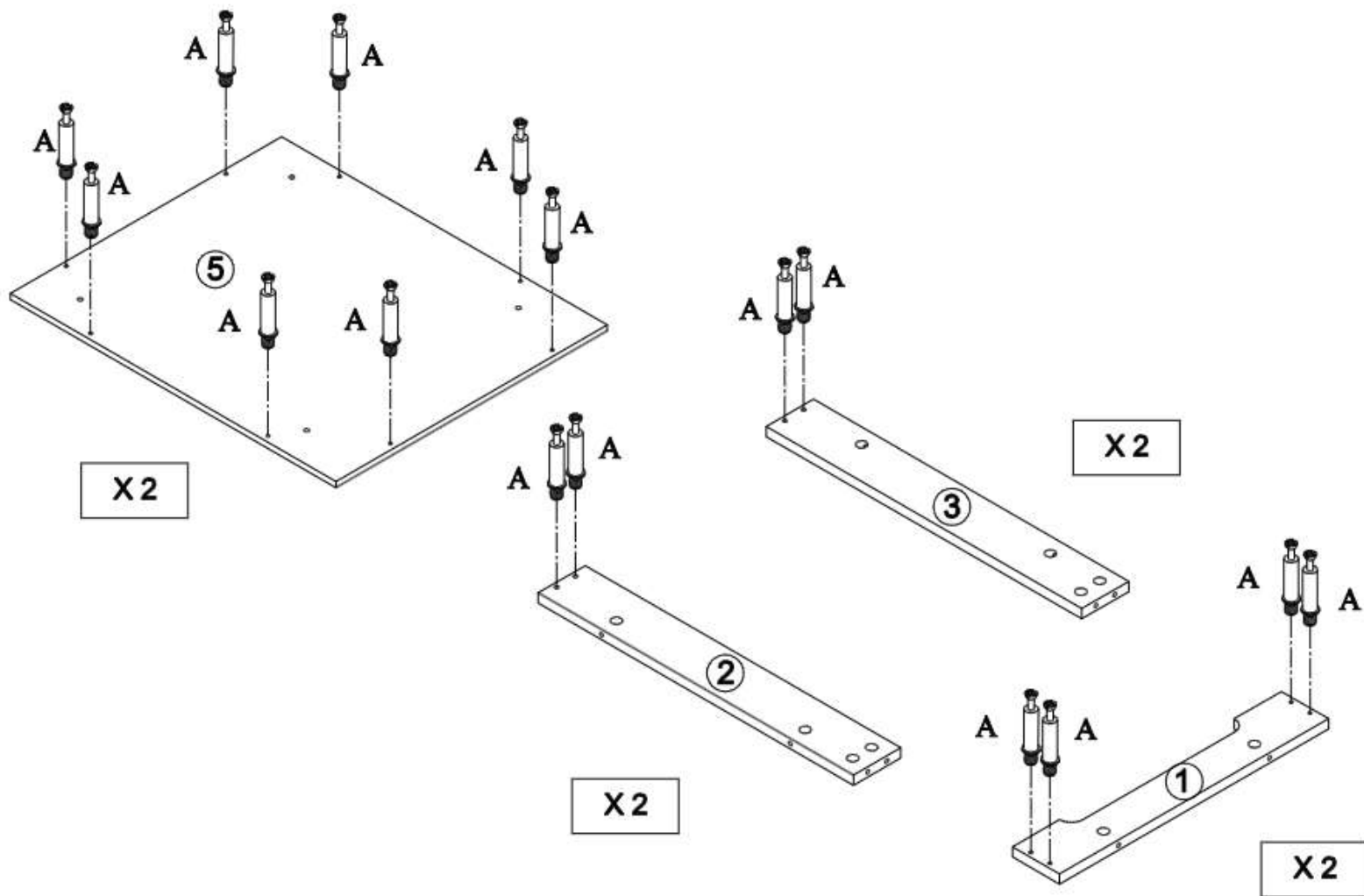
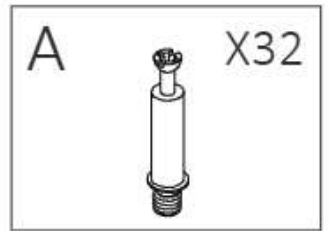

Step 2

I. Attach panel (4) to panel (3), insert cam-lock (B) into the holes on panel (4), then turn clockwise to lock onto cam-bolt.

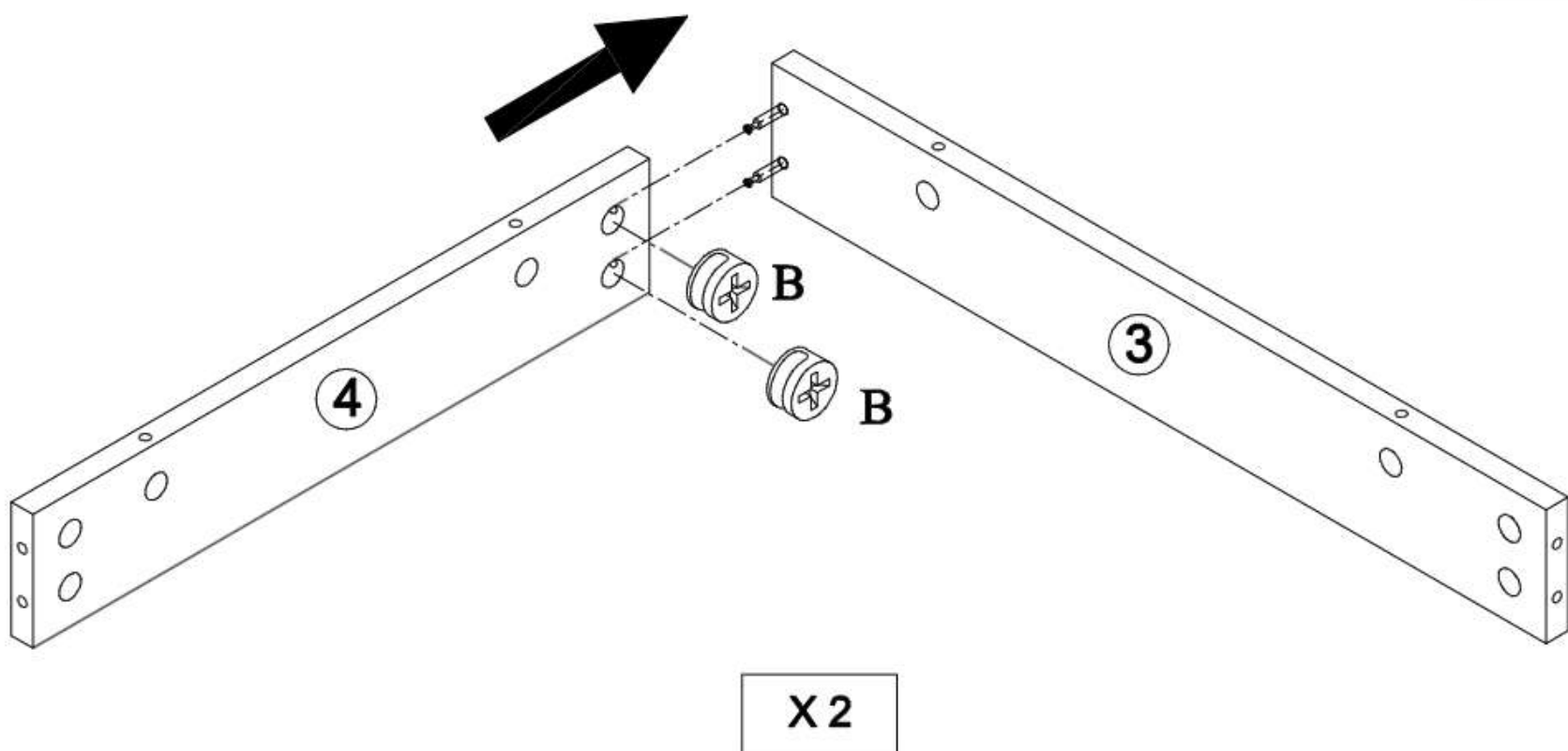
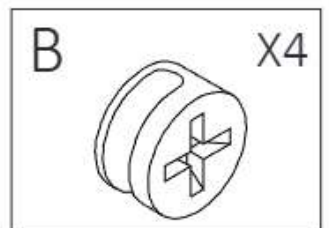

Step 3

I. Attach panel (2) to panel (4), insert cam-lock (B) on panel (4), then turn clockwise to lock onto cam-bolt.

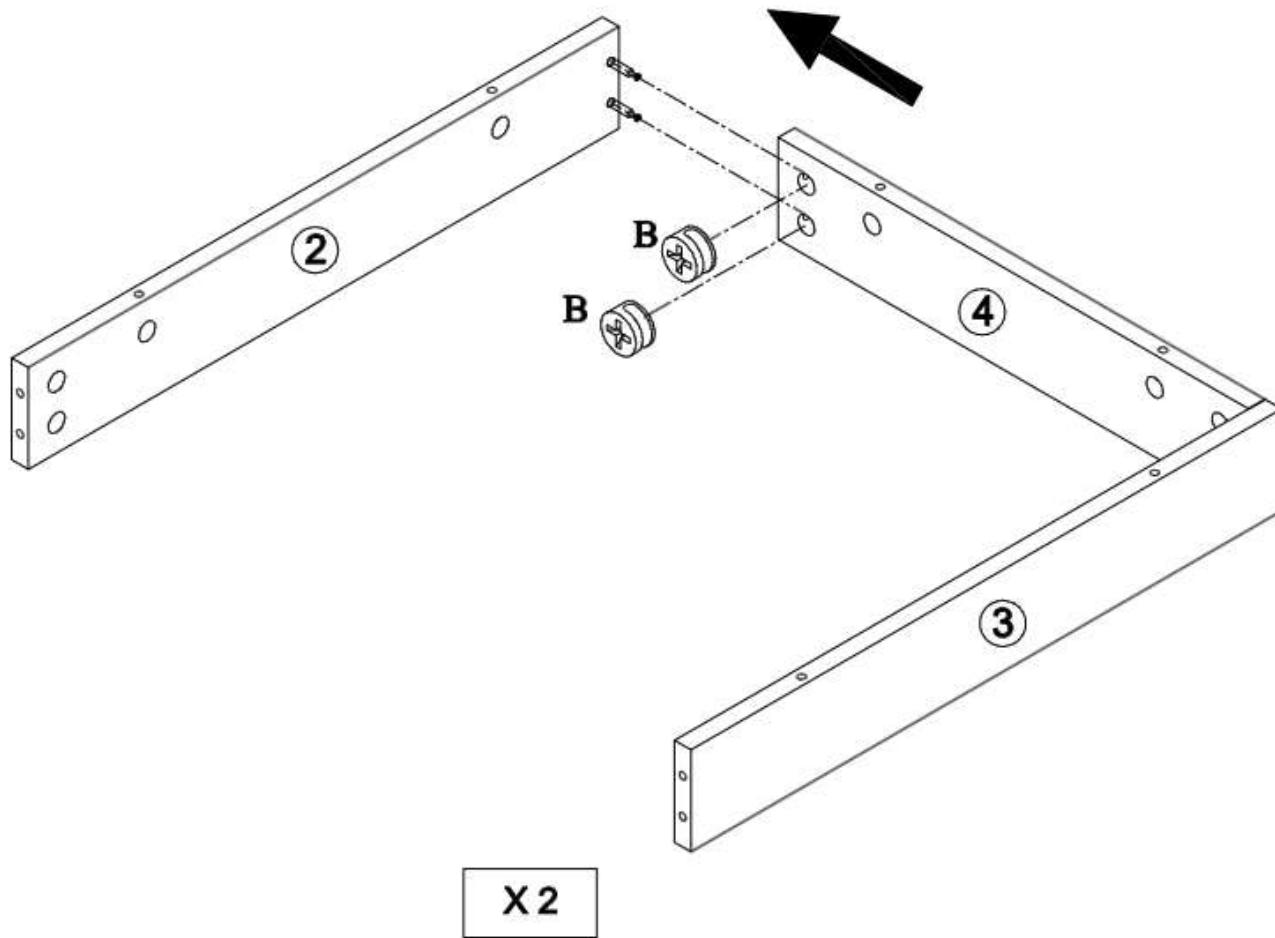
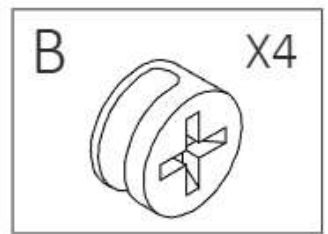

Step 4

I. Attach panel (1) to panel (2,3), insert cam-lock (B) on panel (2,3), then turn clockwise to lock onto cam-bolt.

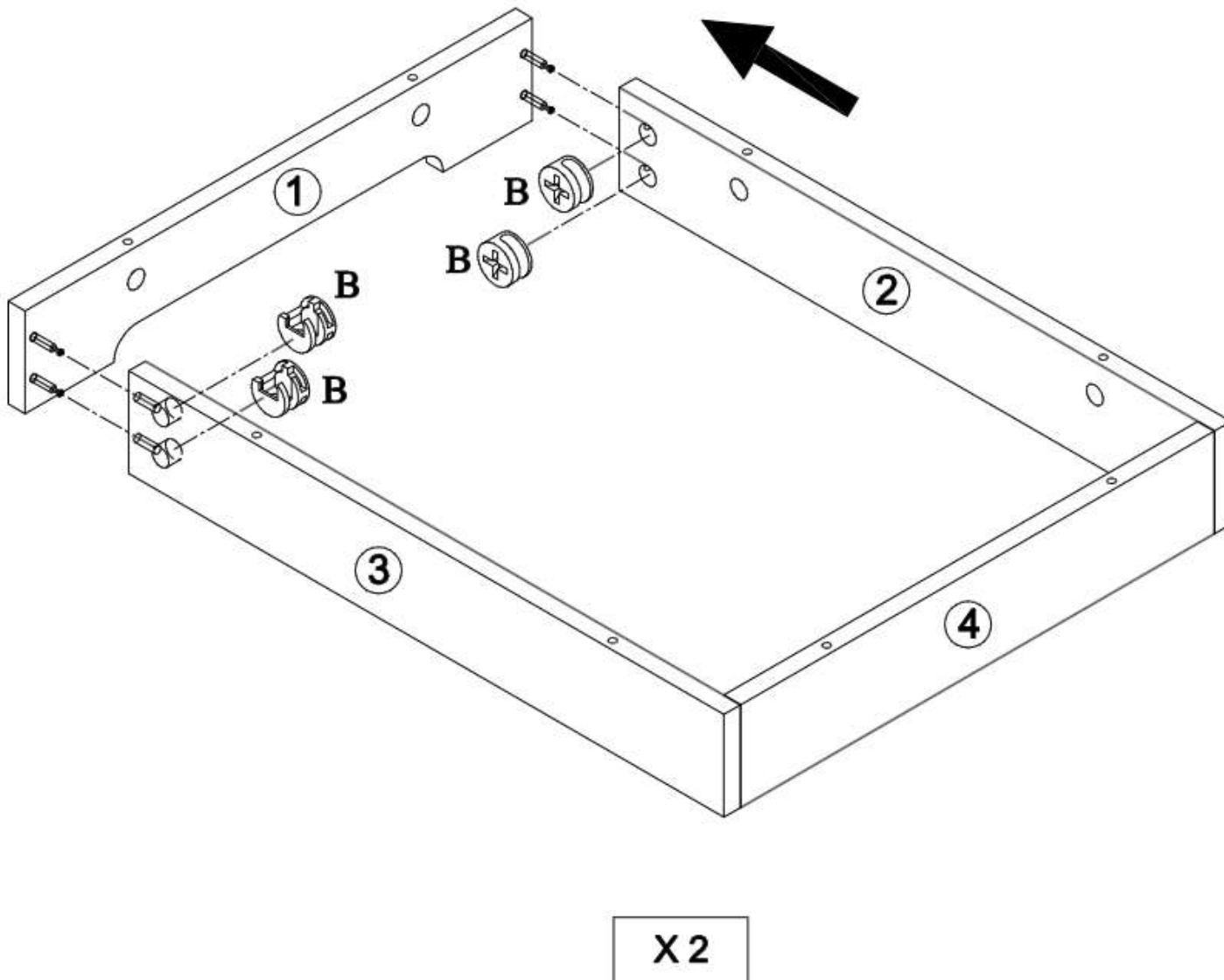
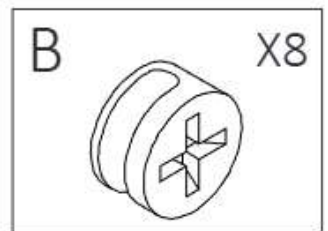

Step 5

I. Attach panel (1,2,3,4) on to panel (5), insert cam-lock (B) into the panel (1,2,3,4), then turn clockwise to lock onto cam-bolt.

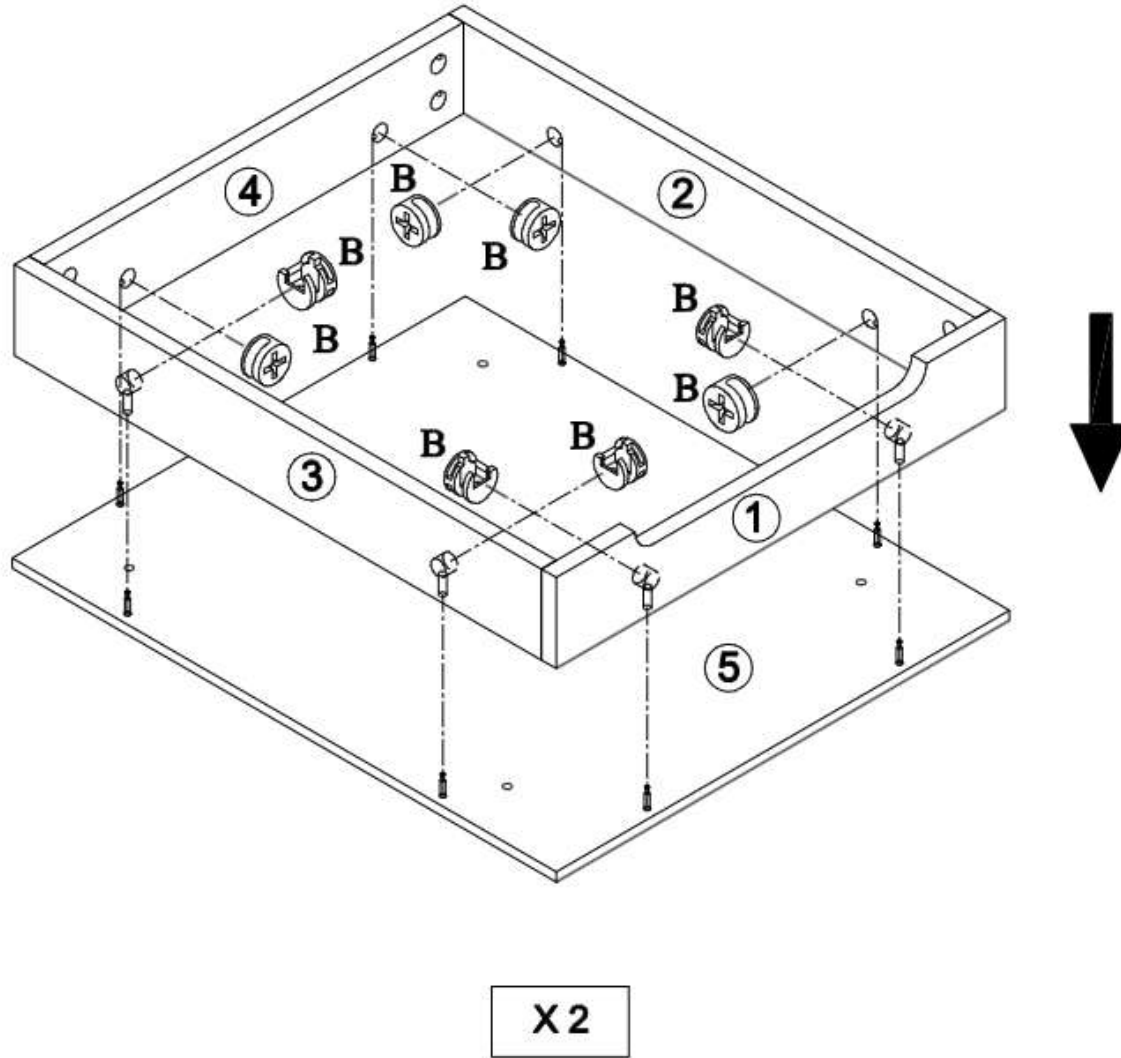
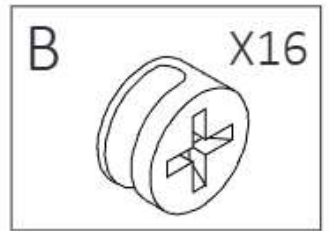

Step 6

I. Screw in cam-bolt (A) into the designated holes on panel (6,7).

II. Insert wood dowel (C) to panel (7).

III. Using screw (J) secure slide rail CL (N) to panel (7) with screwdriver tighten.

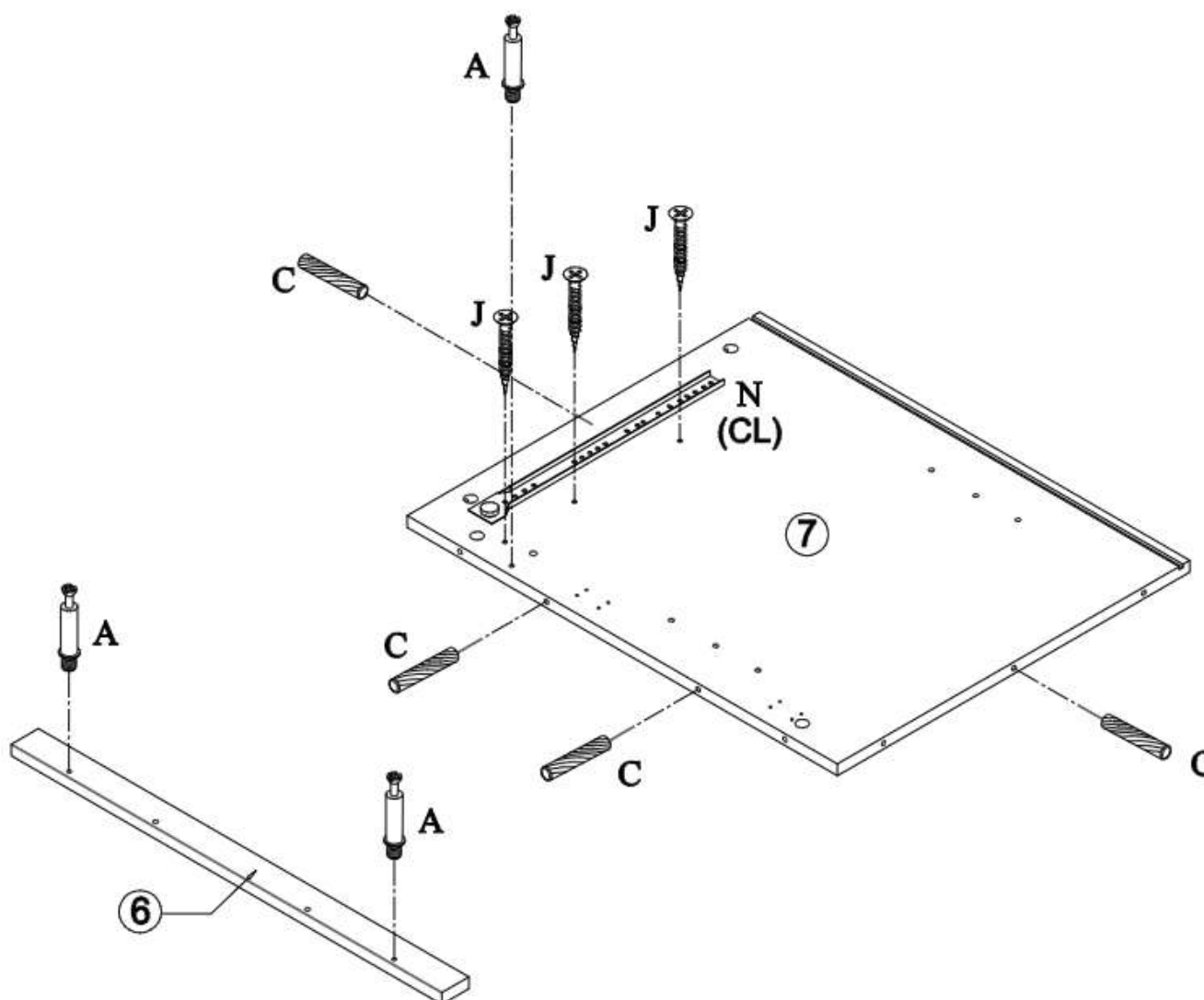
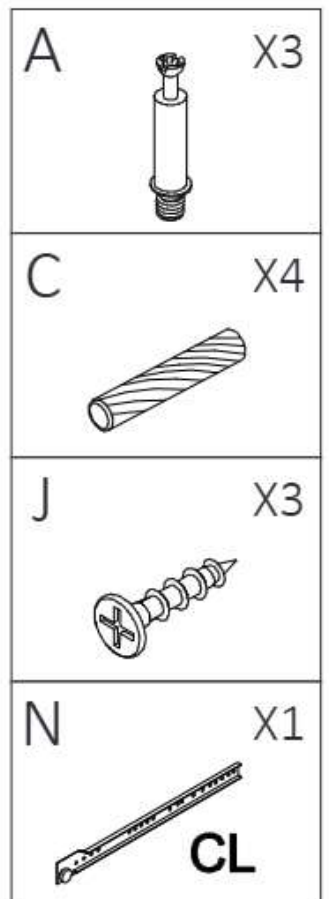

Step 7

I. Attach panel (6) to panel (7), insert cam-lock (B) into the panel (7), then turn clockwise to lock onto cam-bolt.

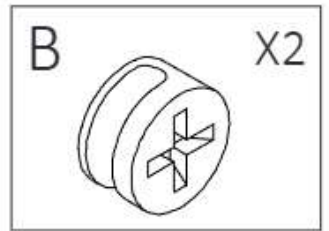
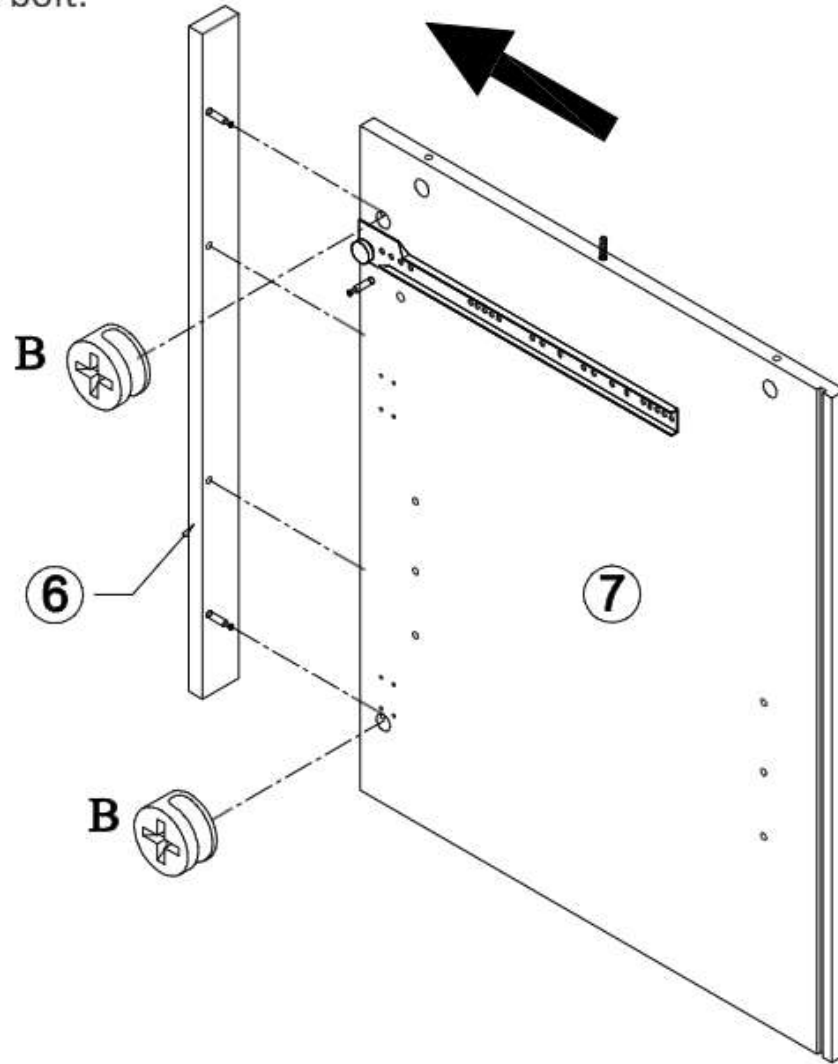

Step 8

I. Screw in cam-bolt (A) into the designated holes on panel (6,8).

II. Insert wood dowel (C) to panel (8).

III. Using screw (J) secure slide rail CL (N) to panel (8) with screwdriver tighten.

IV. Using screw (J) secure slide rail CR (O) to panel (8) another side with screwdriver tighten.

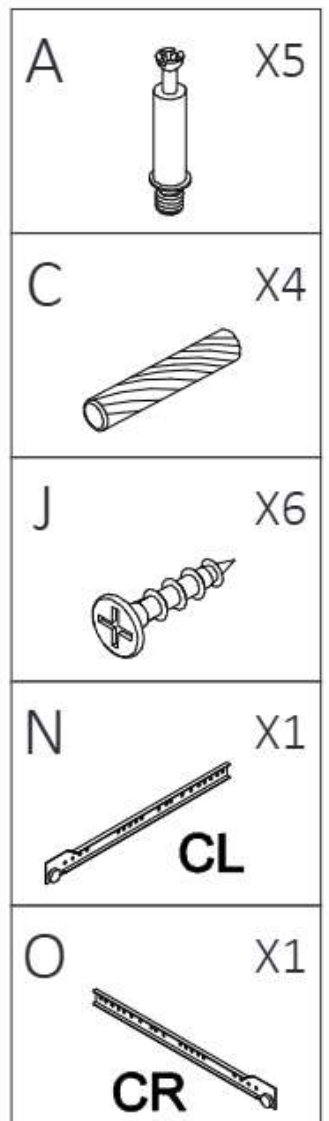
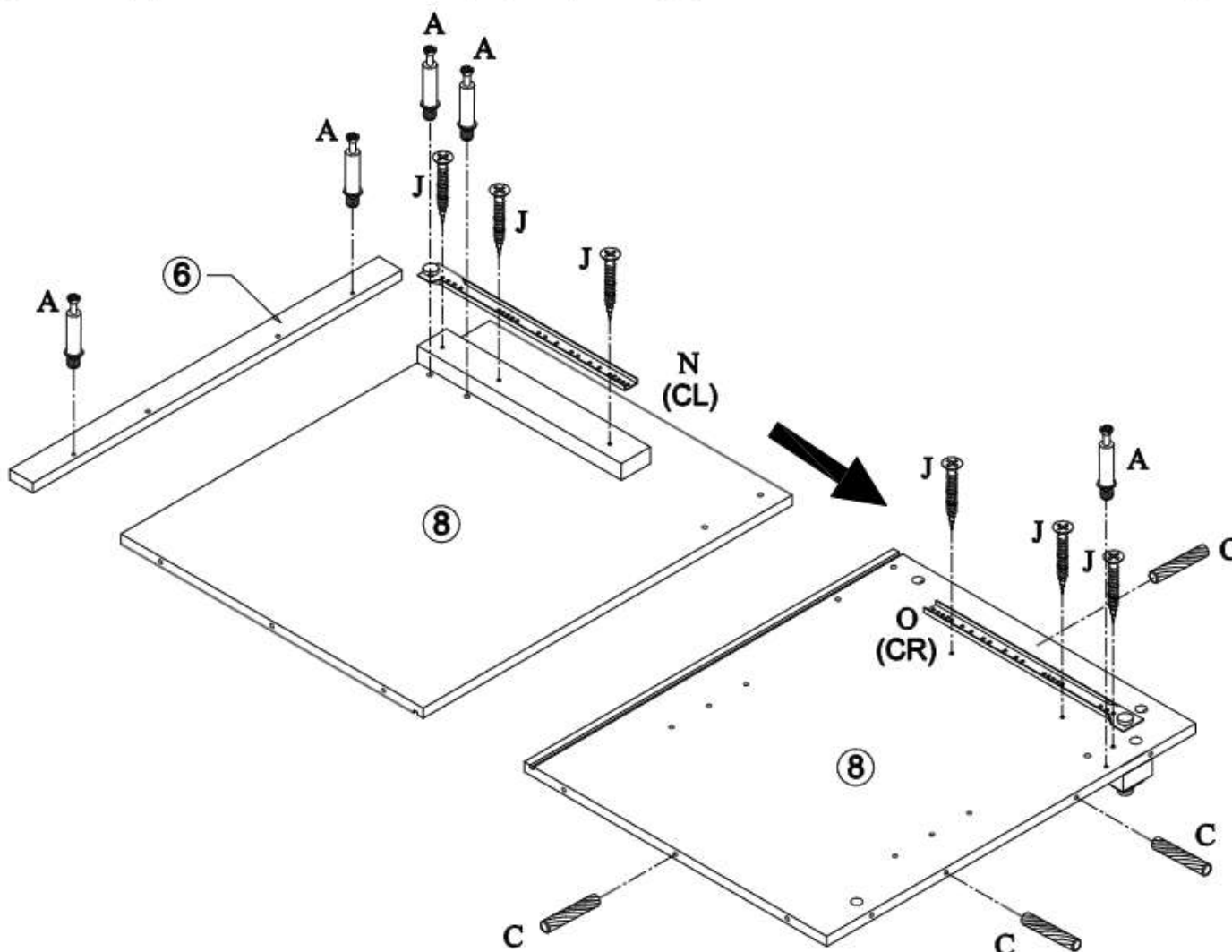

Step 9

I. Attach panel(6)to panel(8),insert cam-lock (B) into the panel (8),then turn clockwise to lock onto cam-bolt.

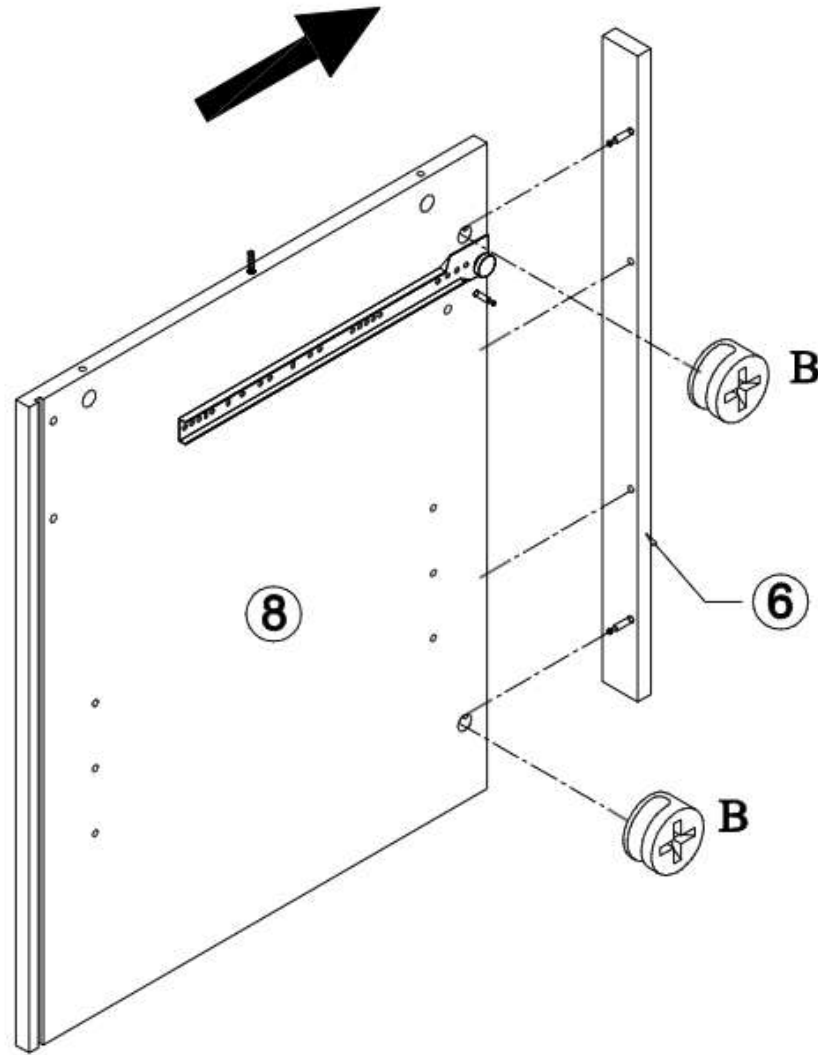
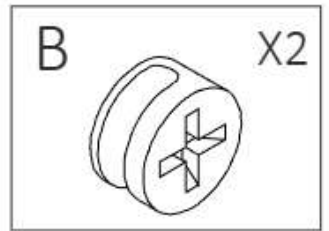

Step 10

I. Insert wood dowel (C) to panel (11).

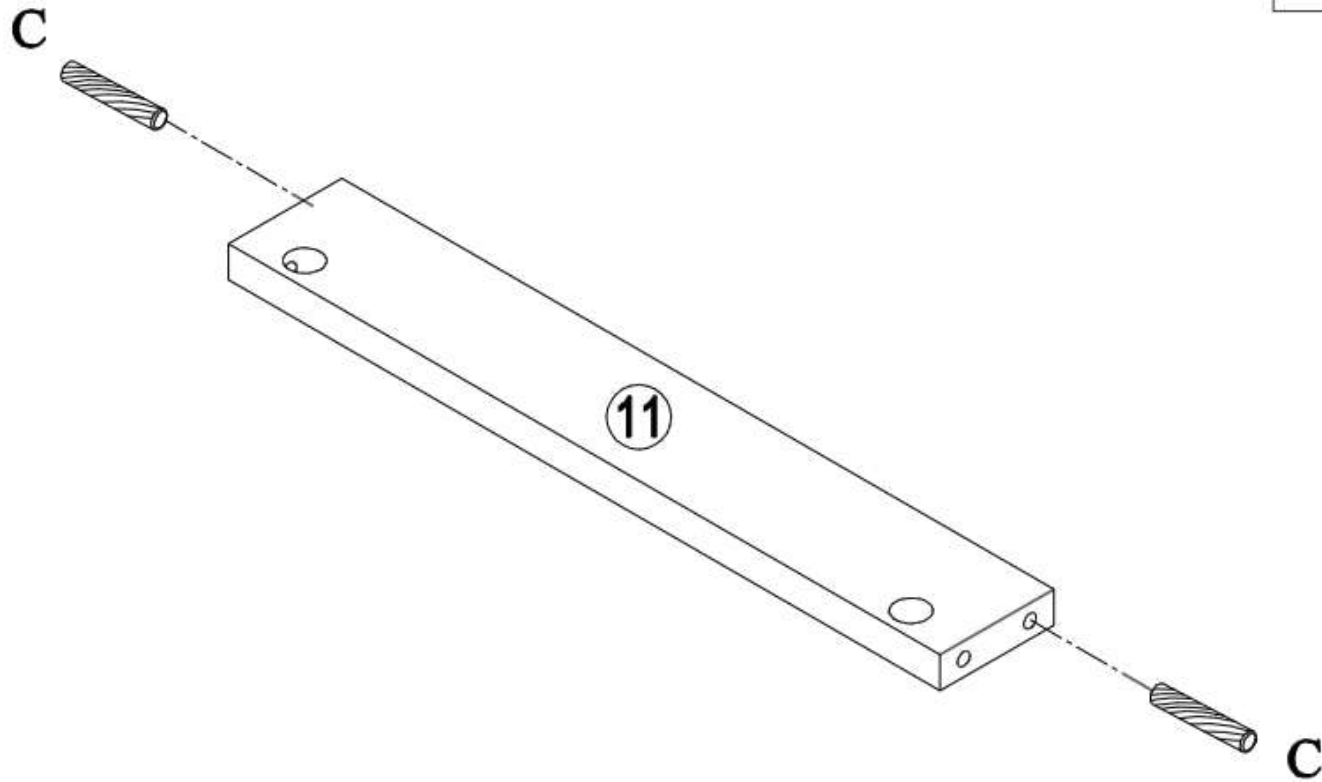
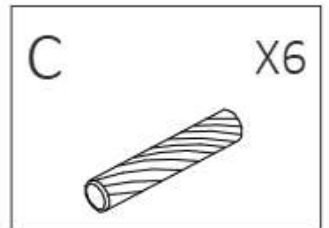

X 3

Step 11

I. Attach panel(11) to panel(7), insert cam-lock (B) into the panel (11), then turn clockwise to lock onto cam-bolt.

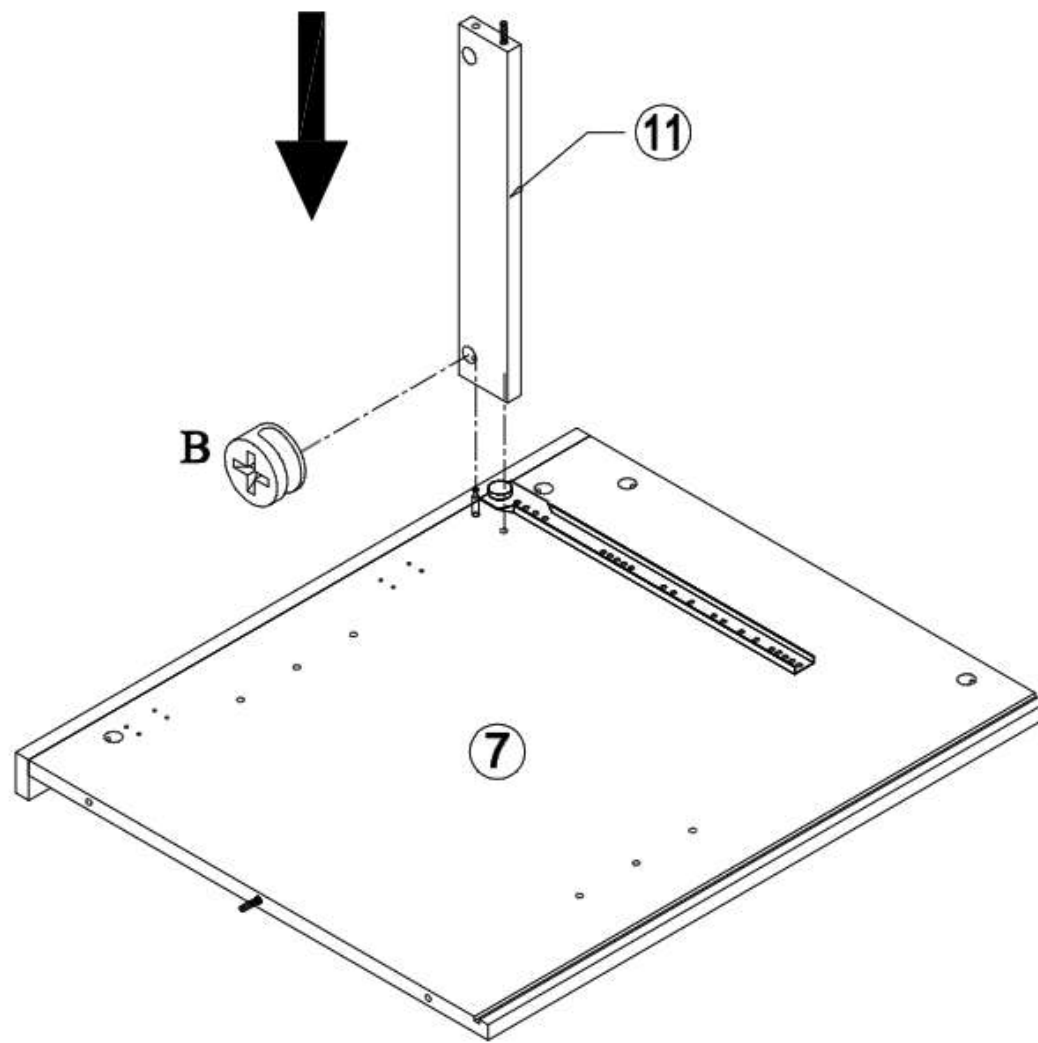
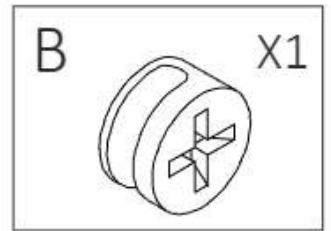

Step 12

I. Attach panel(8) to panel(11), insert cam-lock (B) into the panel (11), then turn clockwise to lock onto cam-bolt.

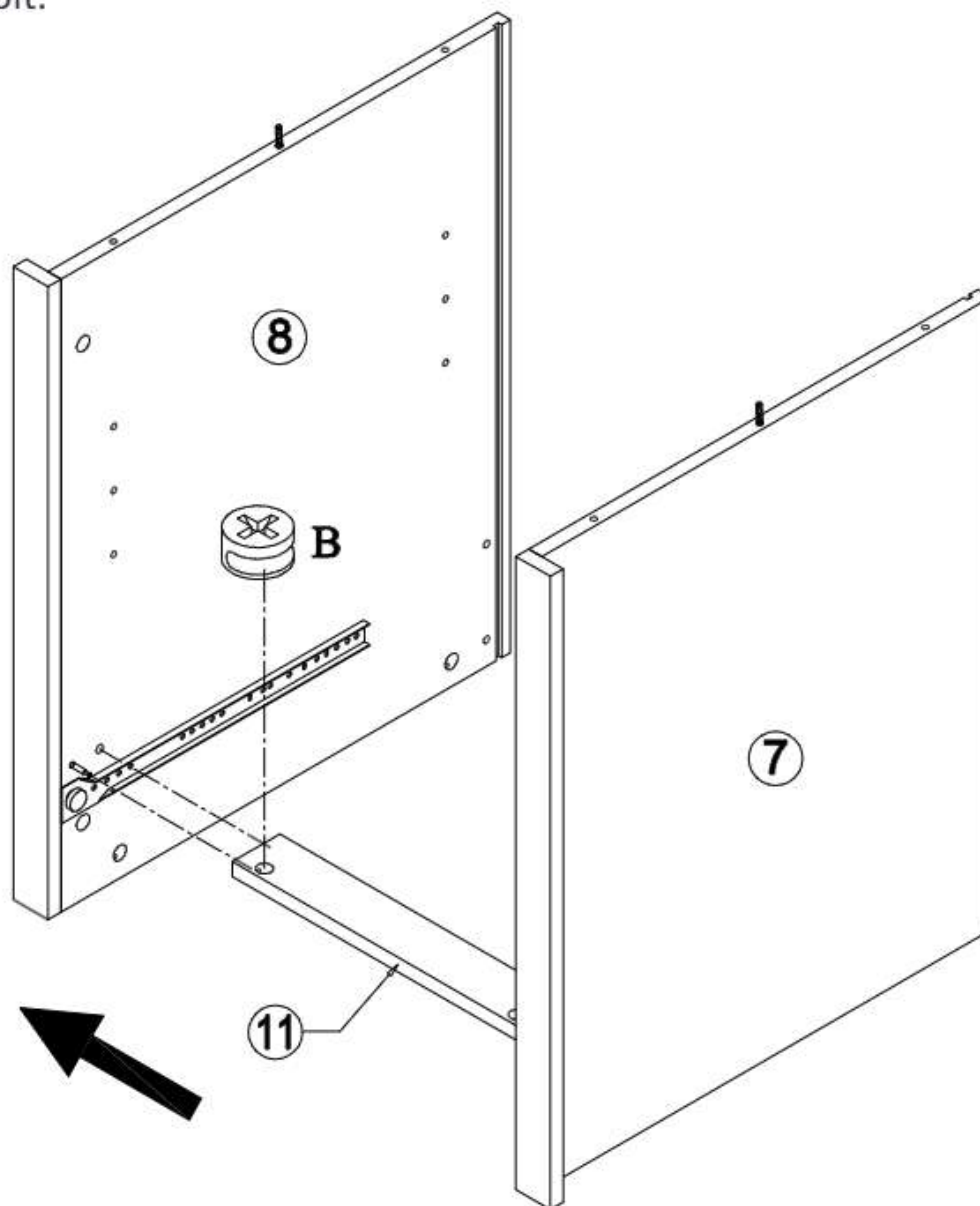
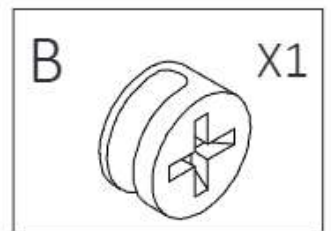

Step 13

I. Attach panel (5) to panel (7,8), using screw (D) attach panel (5) to panel(7,8) with hex key (E) as per diagram.

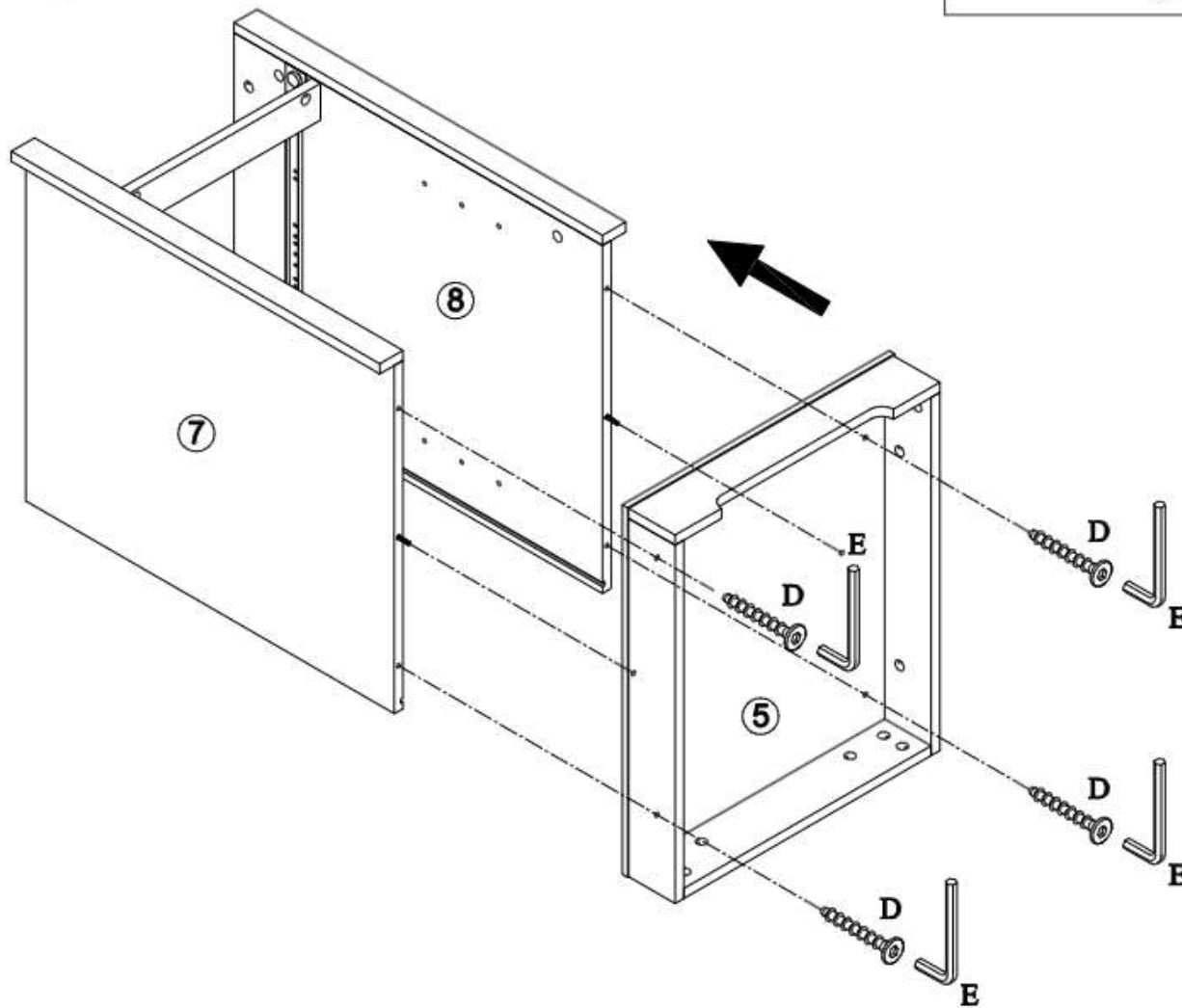
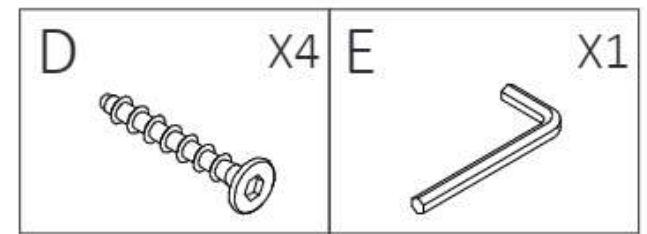

Step 14

I. Screw in cam-bolt (A) into the designated holes on panel (6,9).

II. Insert wood dowel (C) to panel (9).

III. Using screw (J) secure slide rail CL (N) to panel (9) with screwdriver tighten.

IV. Using screw (J) secure slide rail CR (O) to panel (9) another side with screwdriver tighten.

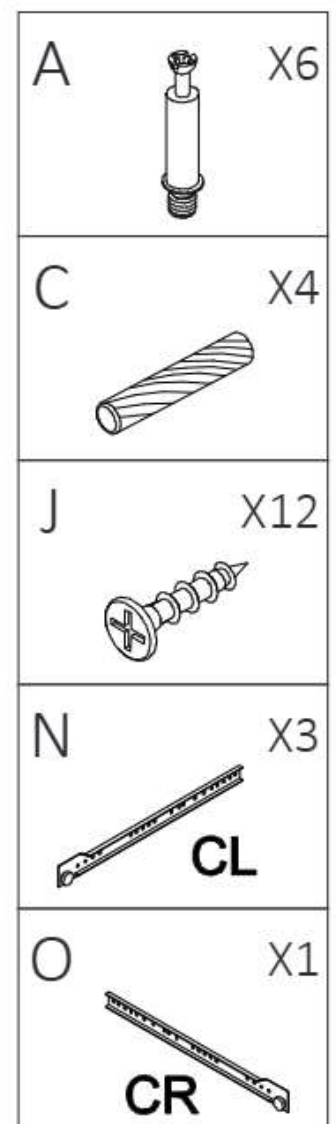
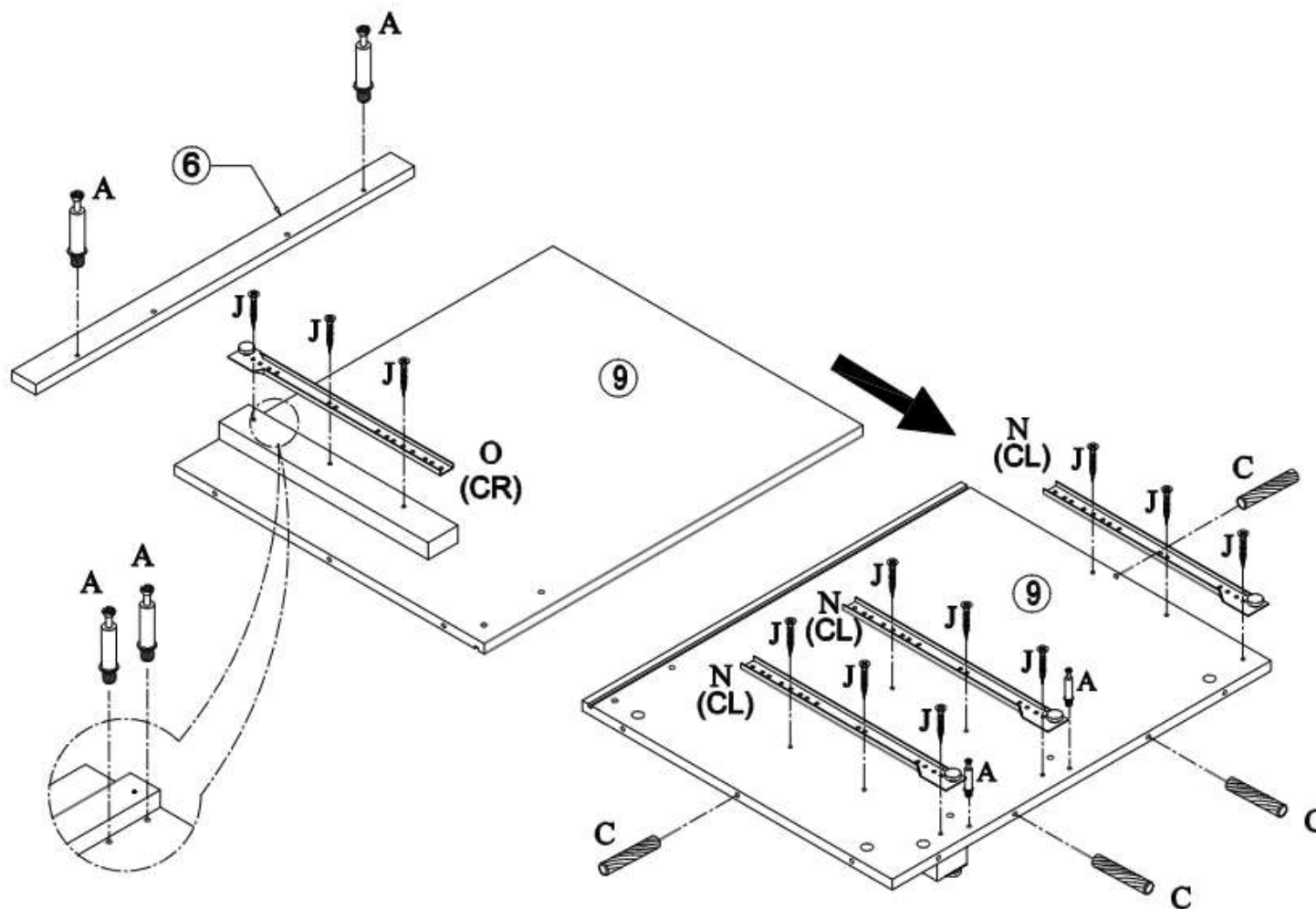

Step 15

I. Attach panel (6) to panel (9), insert cam-lock (B) into the panel (9), then turn clockwise to lock onto cam-bolt.

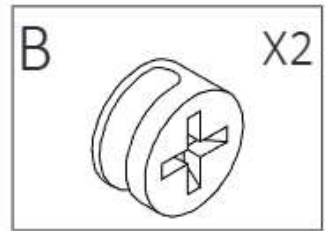
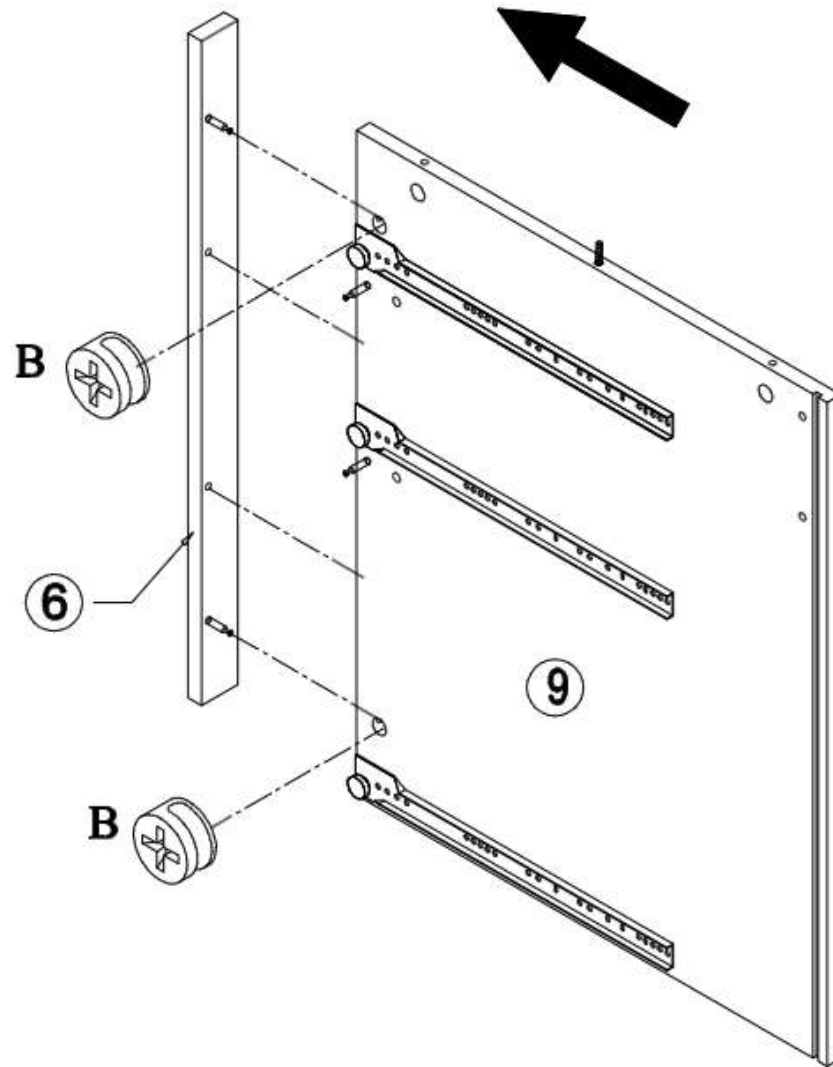

Step 16

- I. Screw in cam-bolt (A) into the designated holes on panel (6,10).
- II. Insert wood dowel (C) to panel (10).
- III. Using screw (J) secure slide rail CR (O) to panel (10) with screwdriver tighten.

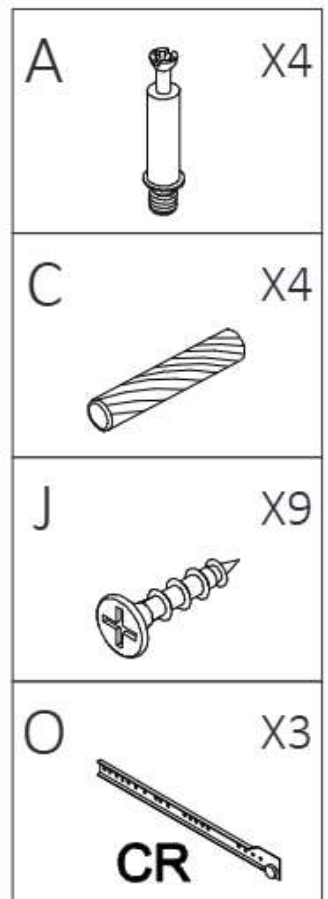
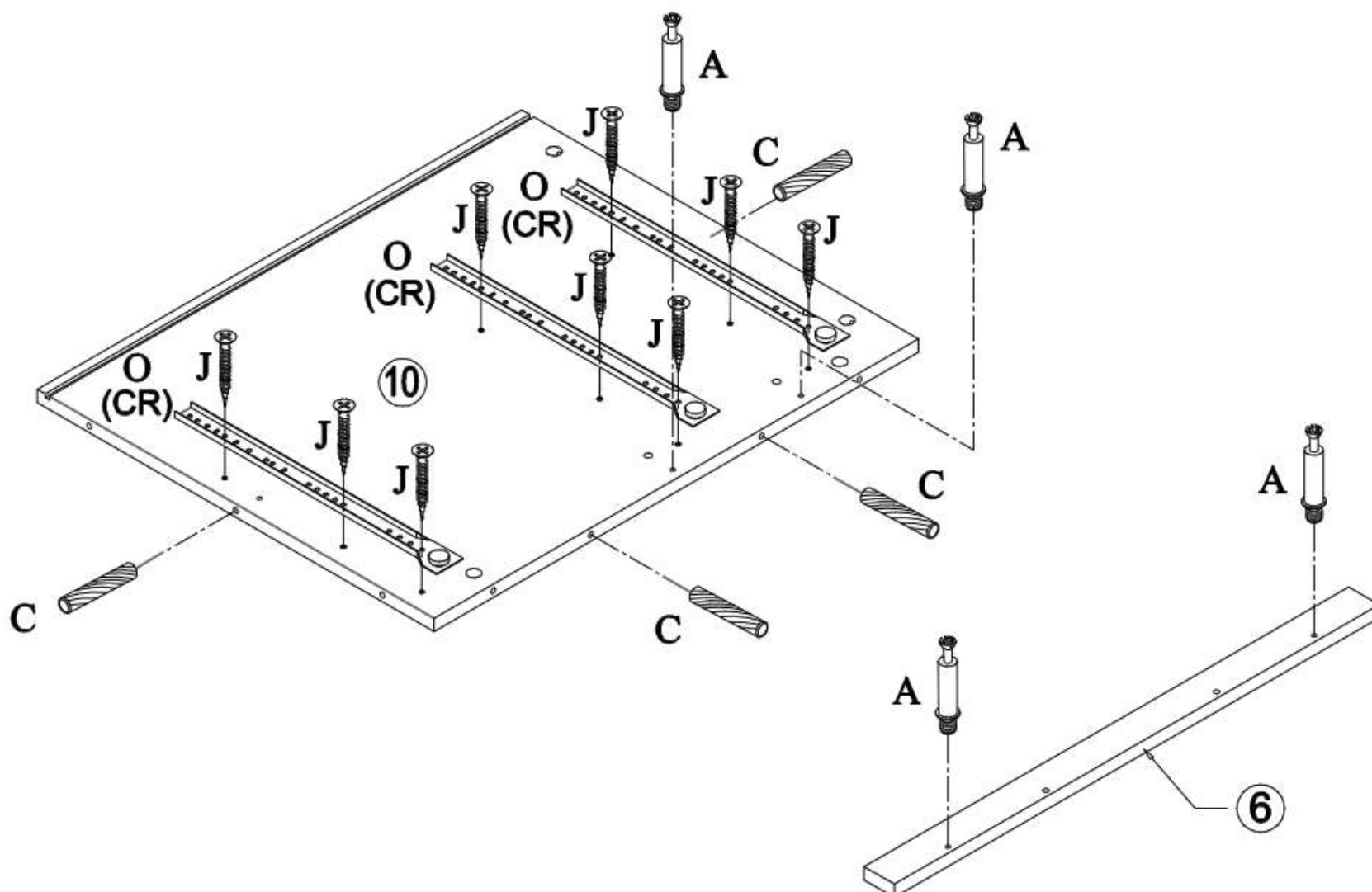

Step 17

I. Attach panel (6) to panel (10), insert cam-lock (B) into the panel (10), then turn clockwise to lock onto cam-bolt.

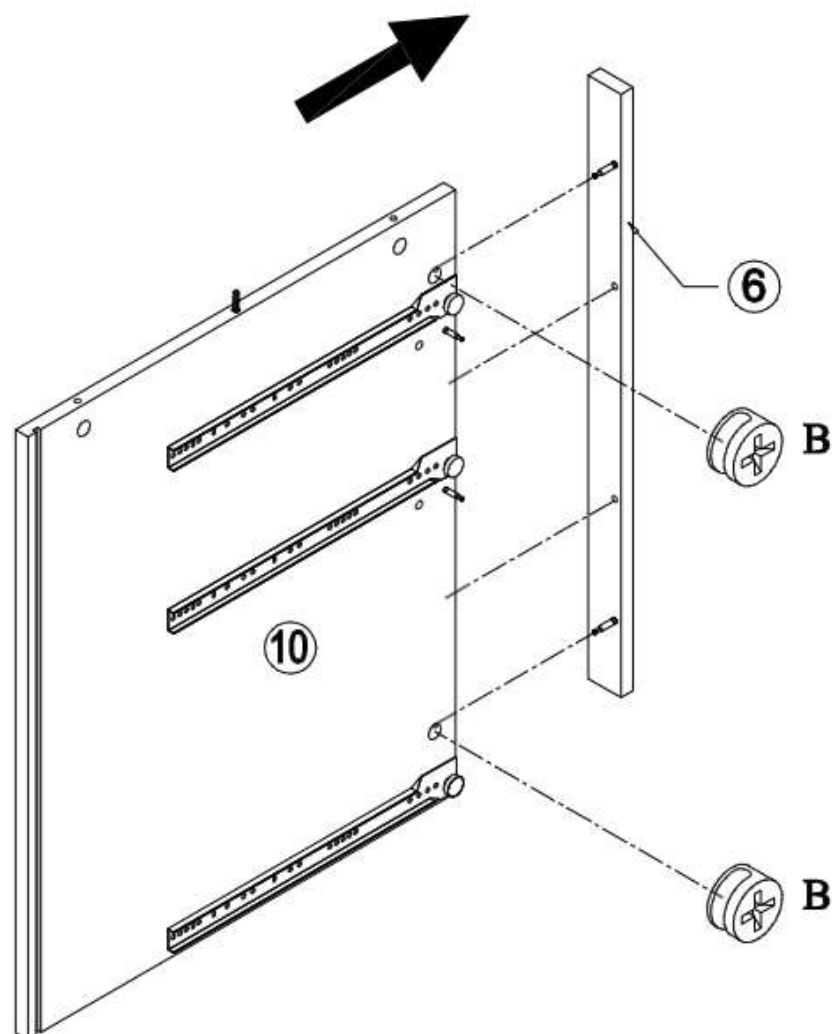
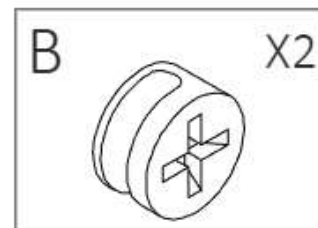

Step 18

I. Attach panel (11,11) on to panel (10), screw in cam-lock (B) into the designated holes on panel (11,11).

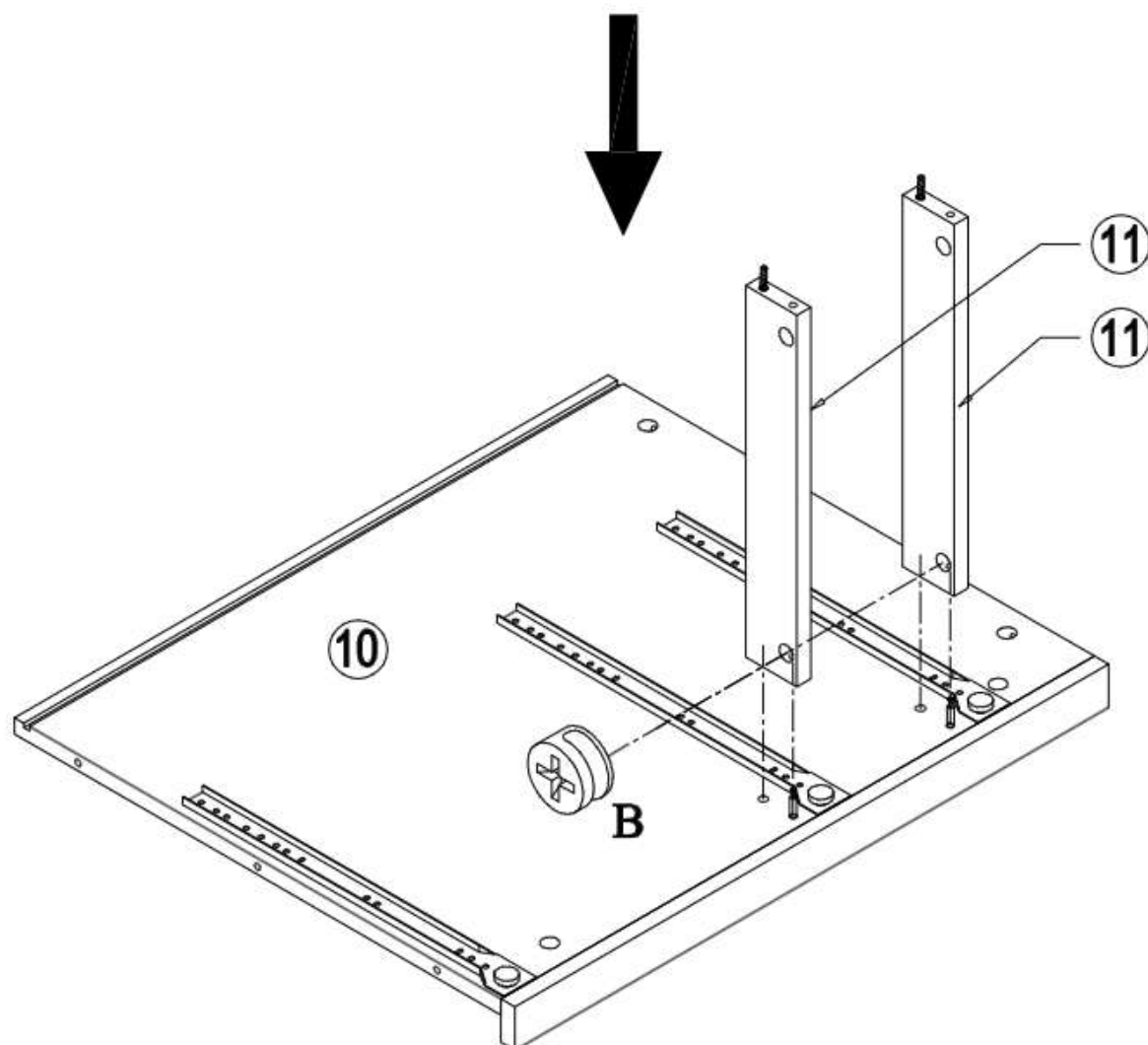
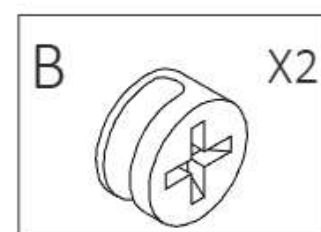

Step 19

I. Attach panel(11,11) to panel(9), insert cam-lock (B) into the panel (11,11), then turn clockwise to lock onto cam-bolt.

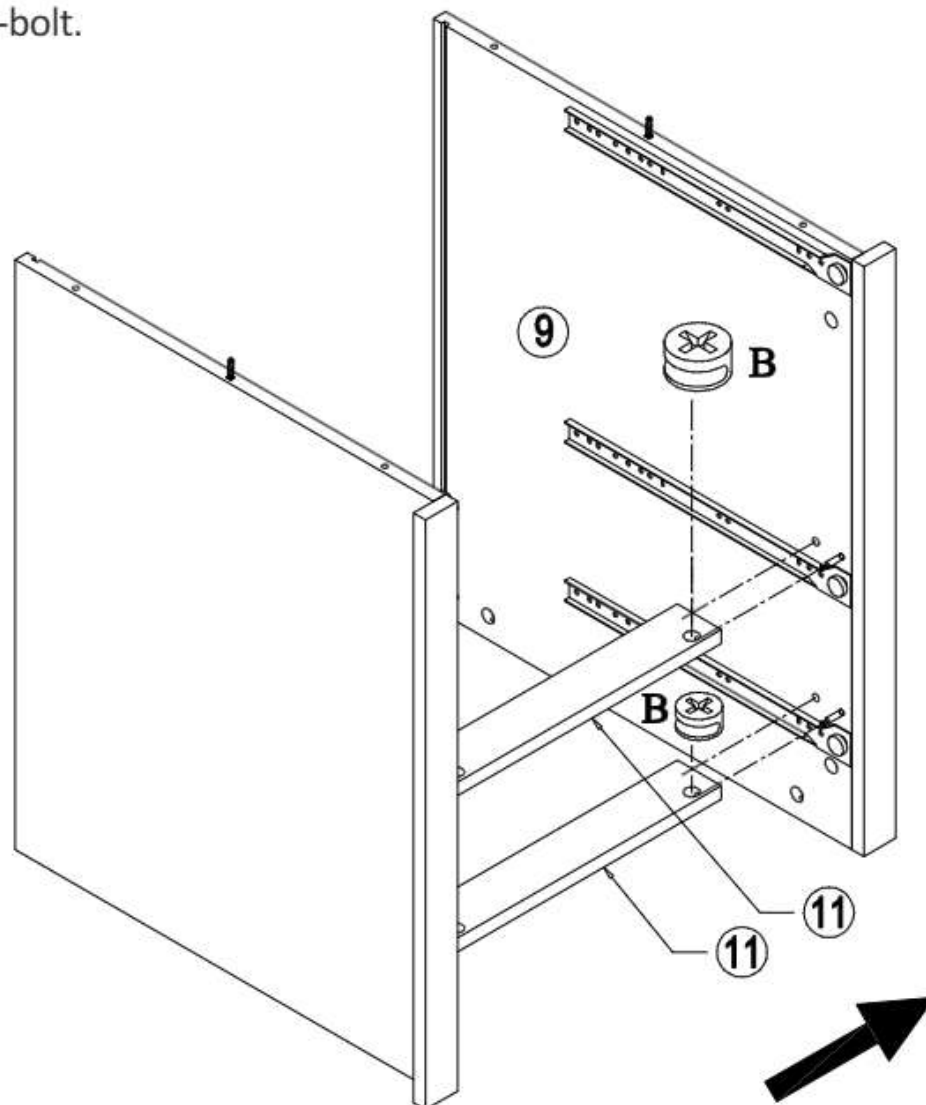
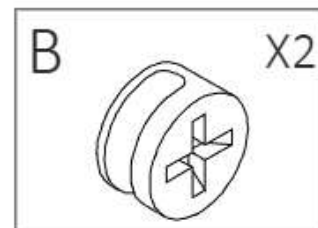

Step 20

I. Attach panel(5) to panel (9,10), using screw (D) attach panel (5) to panel(9,10) with Hex key (E) as per diagram.

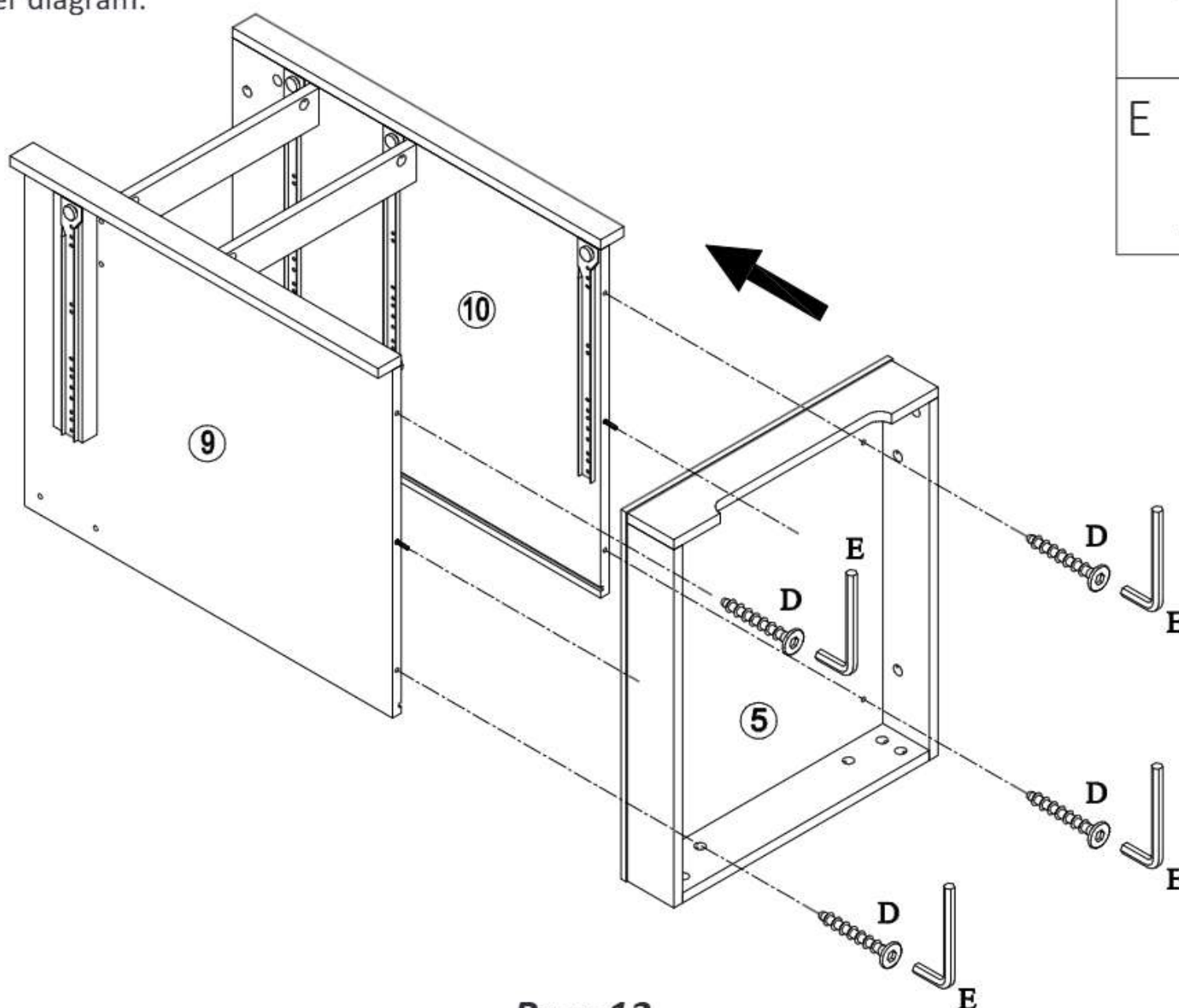
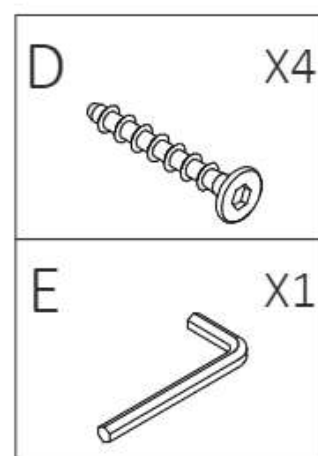

Step 21

I. Attach panel (13) on to panel (8), screw in cam-lock (B) into the designated holes on panel (13).

II. Attach panel (14) on to panel (8), using screw (D) attach panel (8) to panel (14) with hex key (E) as per diagram.

III. Attach panel (13) on to panel (9), screw in cam-lock (B) into the designated holes on panel (13).

IV. Attach panel (14) on to panel (9), using screw (D) attach panel (9) to panel (14) with hex key (E) as per diagram.

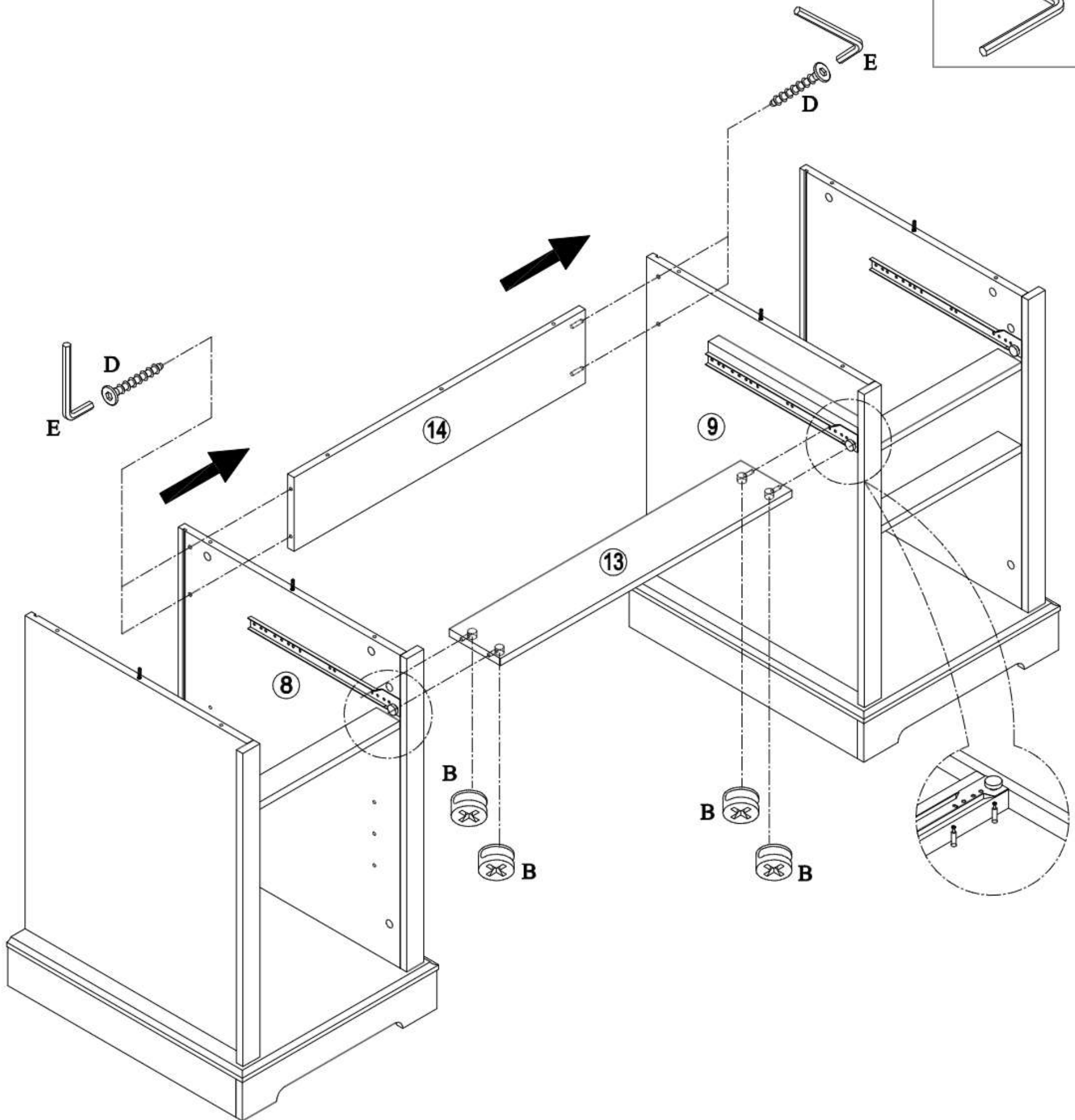
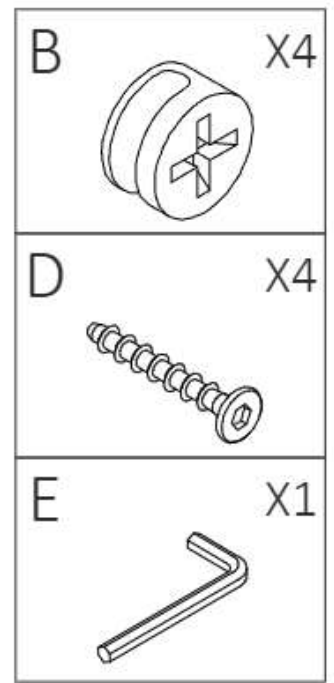

Step 22

I. Place panel (12,12) as per diagram.

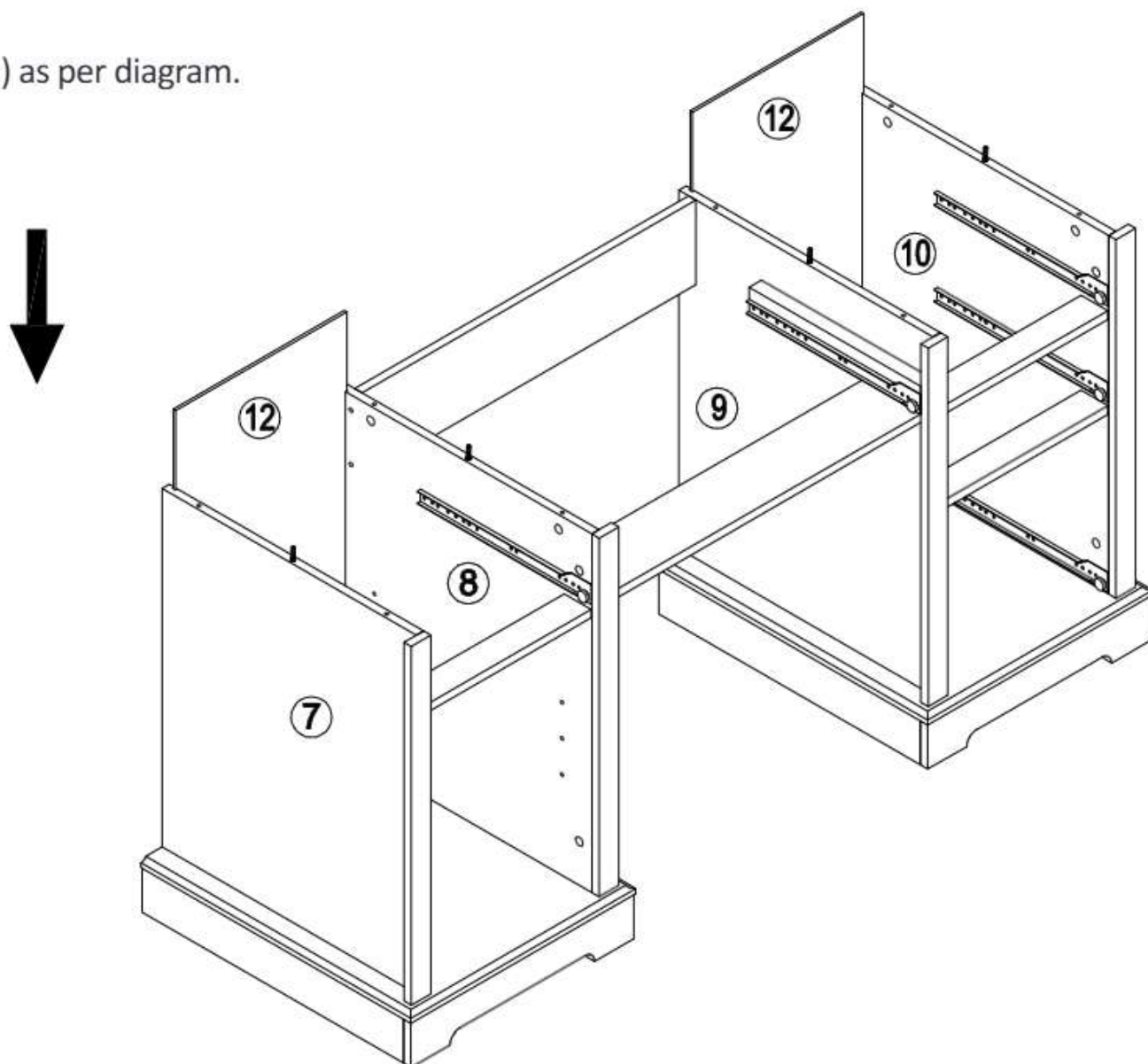

Step 23

I. Screw in cam-bolt (A) into the designated holes on panel (15).

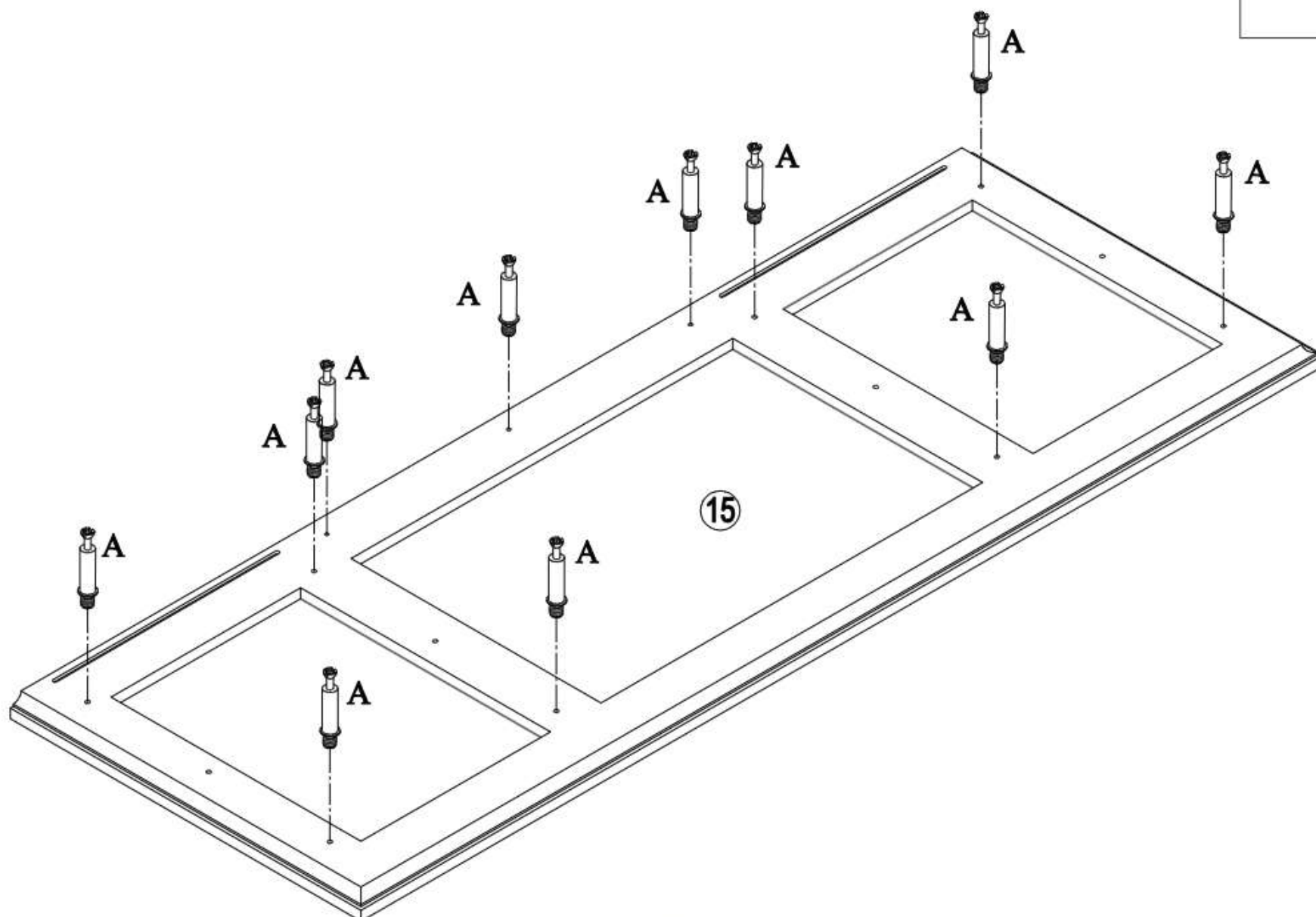
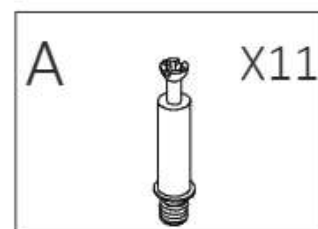

Step 24

I. Attach panel (15) to panel (7,8,14,9,10), Screw in cam-lock (B) into the designated holes on panel(7,8,14,9,10), then turn clockwise to lock onto cam-bolt.

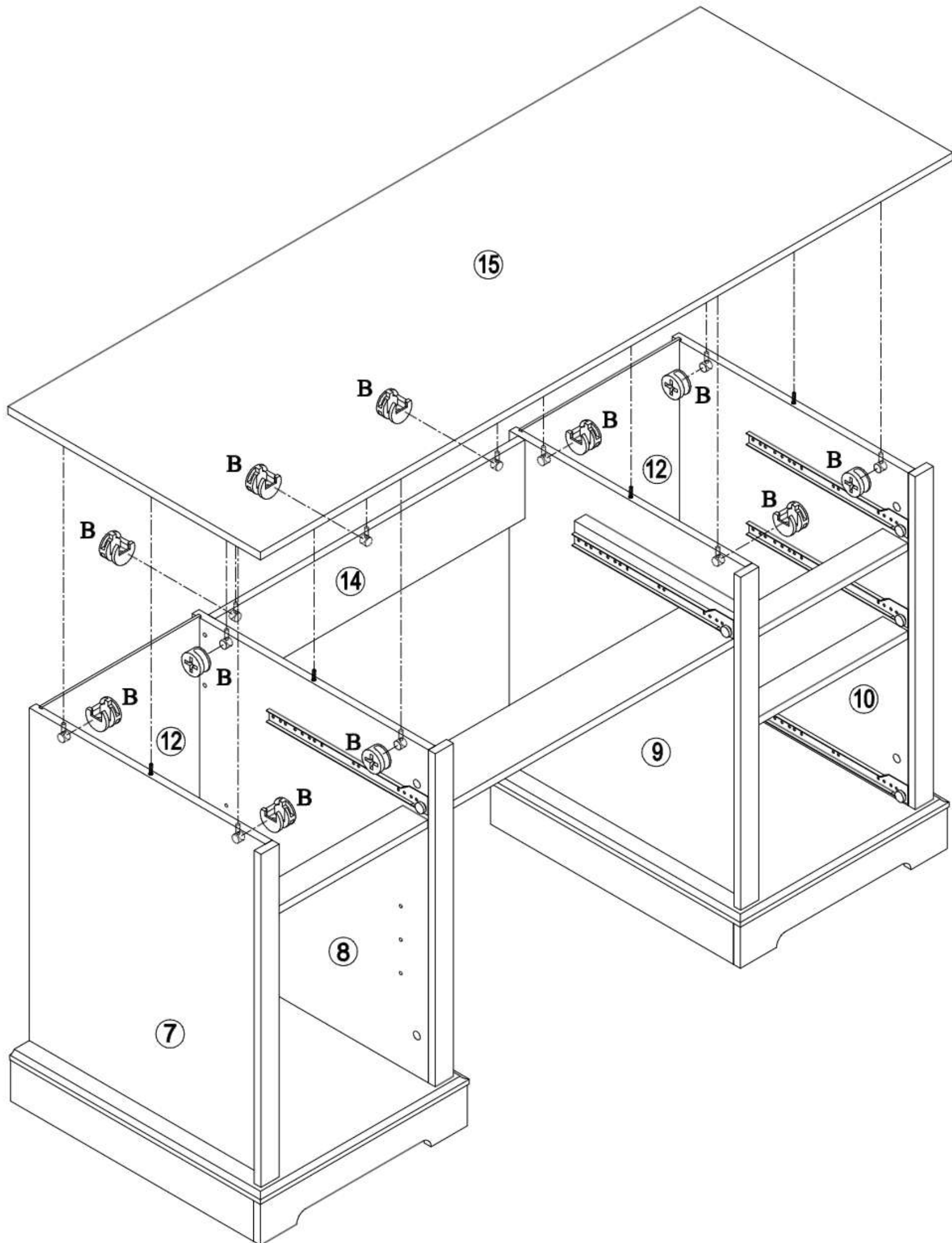
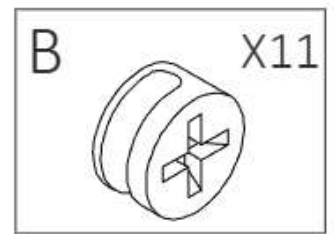

Step 25

I.Screw in cam-bolt (A) into the designated holes on panel (16,17,18,19).

II.Using Screw (G) secure Handle (F) to panel (16,17,18,19) with screwdriver as per diagram.

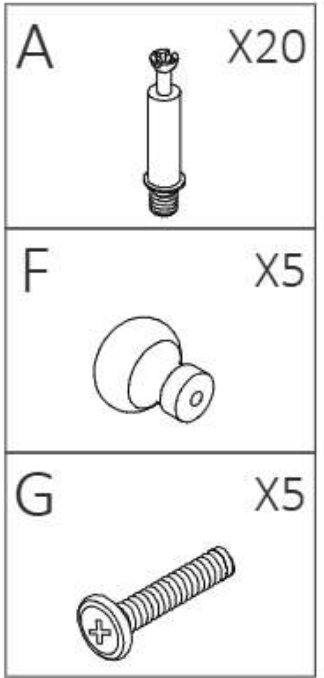
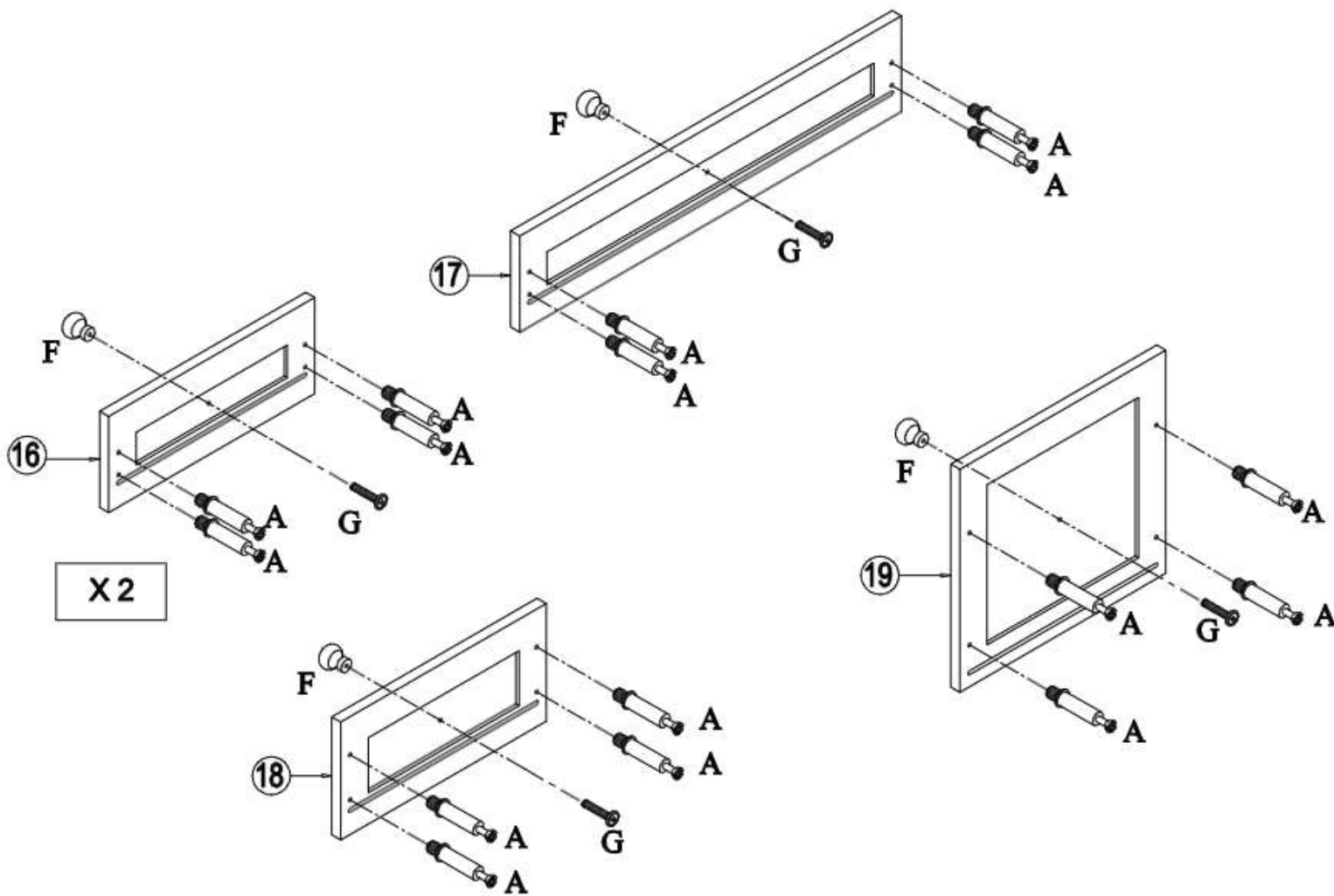

Step 26

I.Attach panel (22) on to panel (20),using screw (D) attach panel (20) to panel(22) with hex key (E) as per diagram.

II.Attach panel (22) on to panel (21),using screw (D) attach panel (21) to panel(22) with hex key (E) as per diagram.

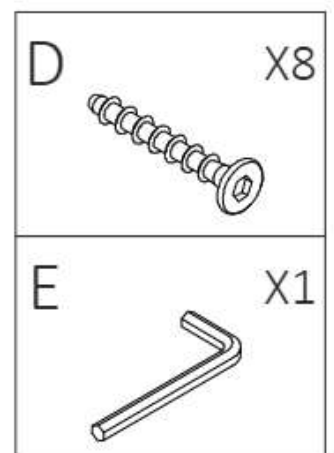
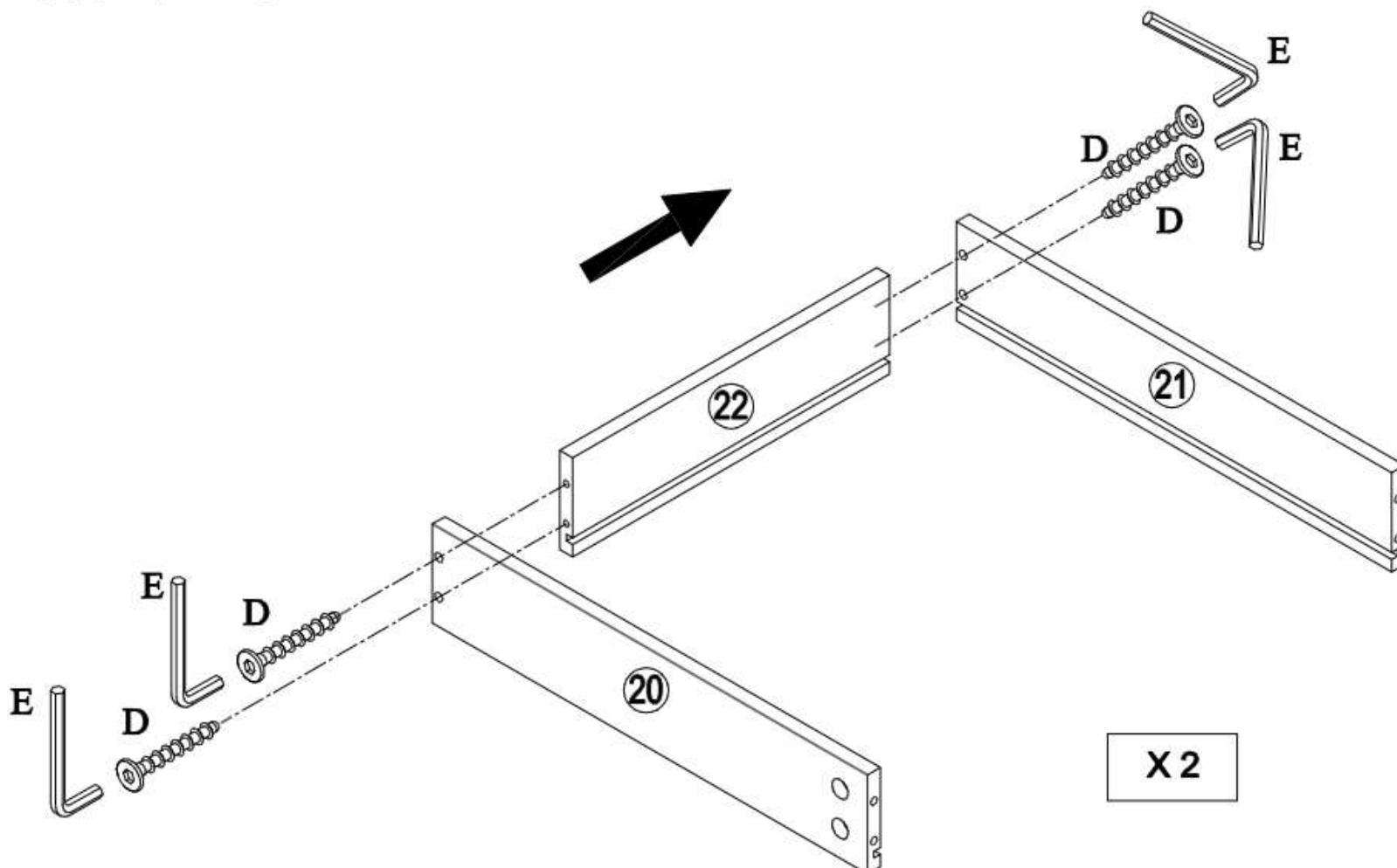

Step 27

I. Place panel (23) as per diagram.

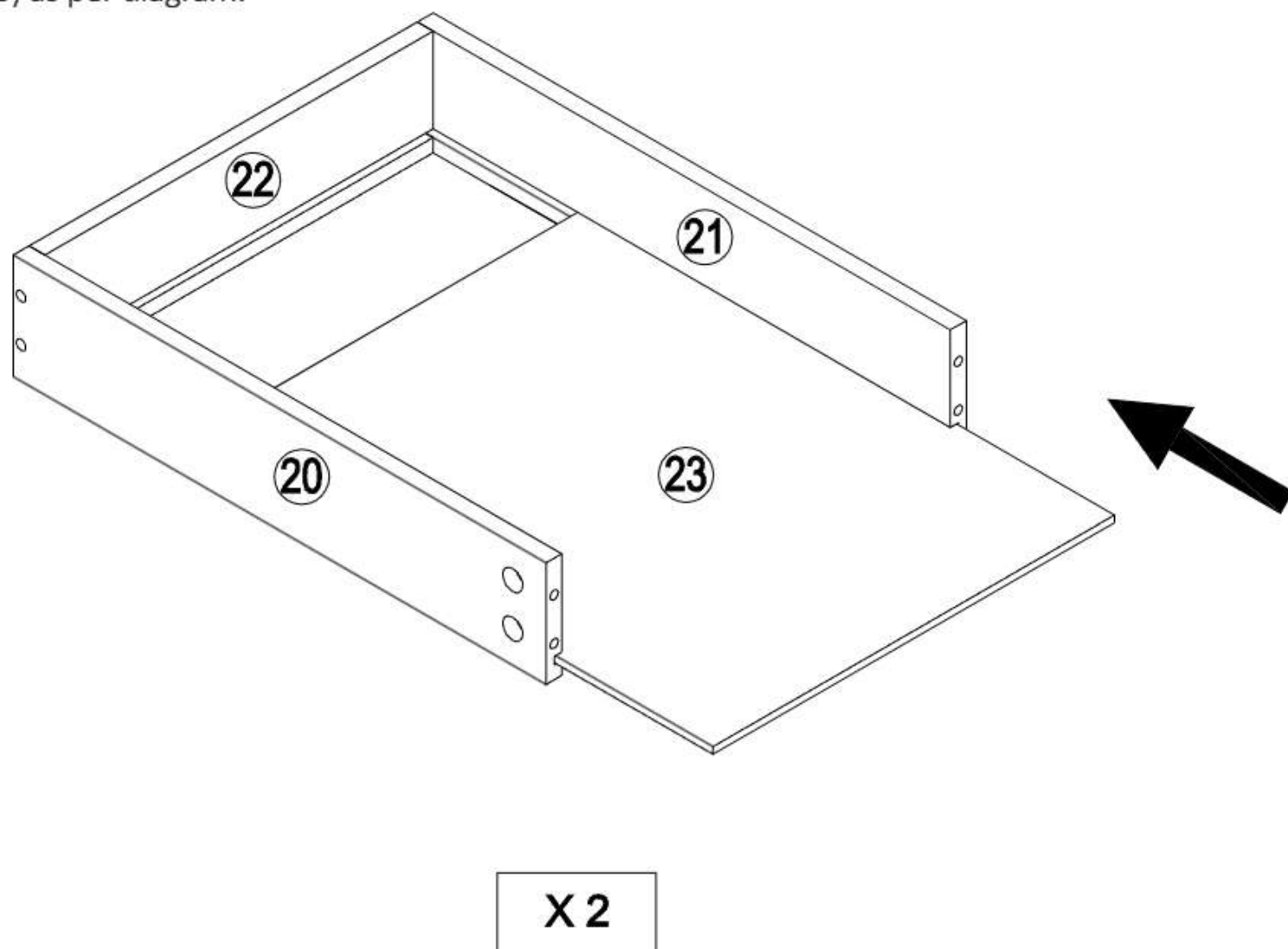

Step 28

I. Attach panel (16) to panel (20,21), insert cam-lock (B) into the panel (20,21), then turn clockwise to lock onto cam-bolt.

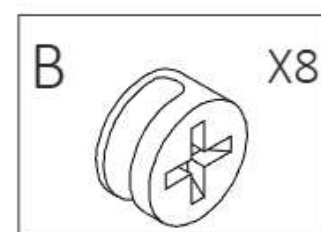
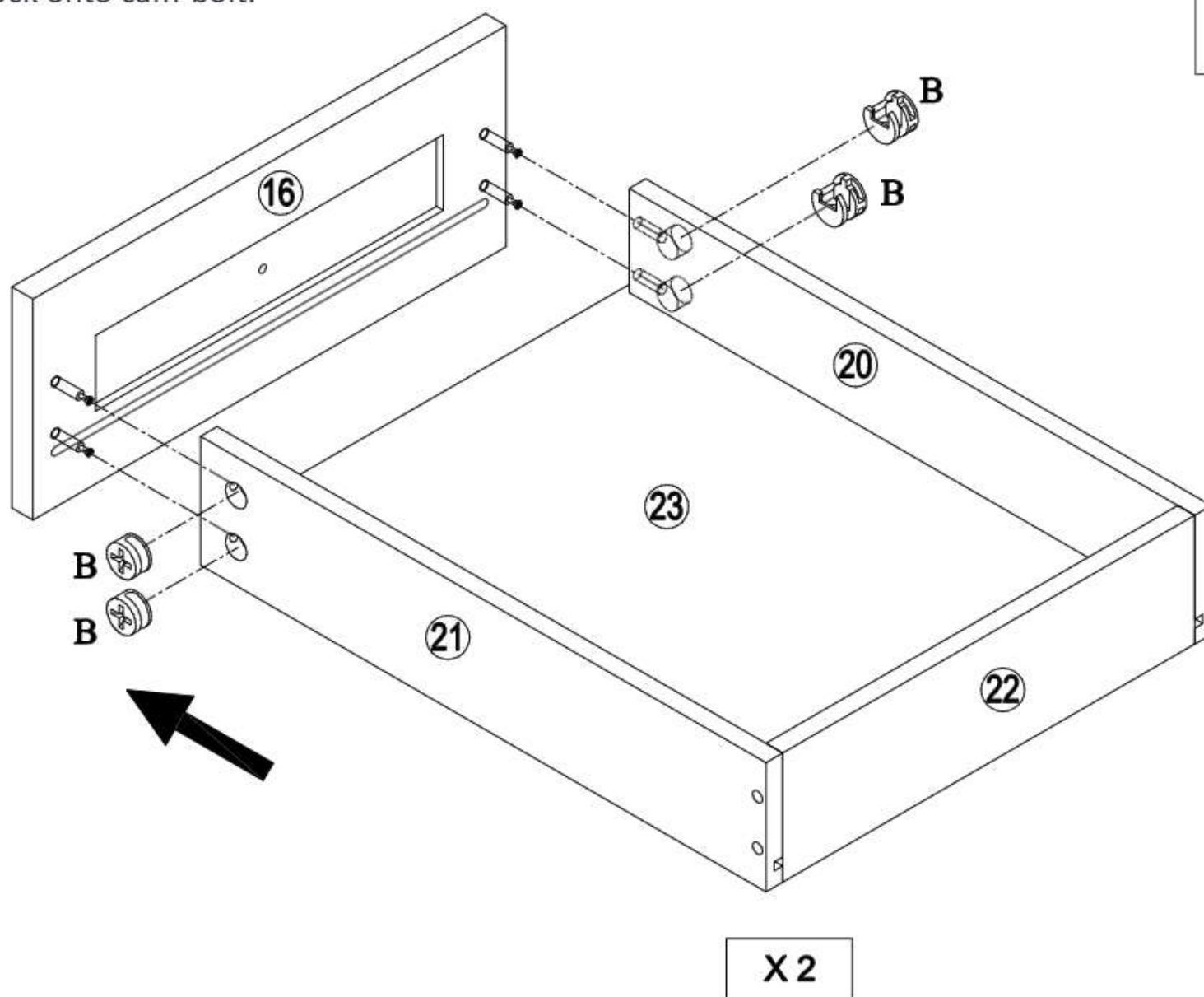

Step 29

I. Using screw (J) secure slide rail DL (P) to panel (20) with screwdriver tighten.

II. Using screw (J) secure slide rail DR (Q) to panel (21) with screwdriver tighten.

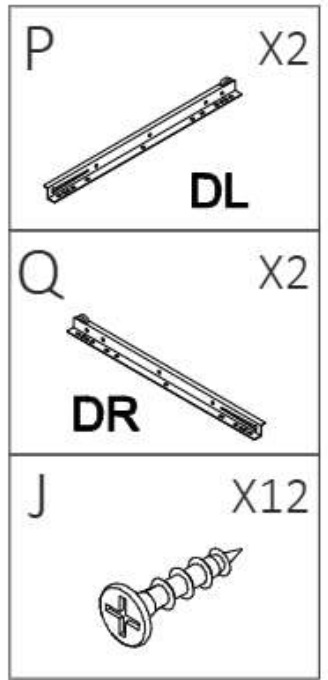
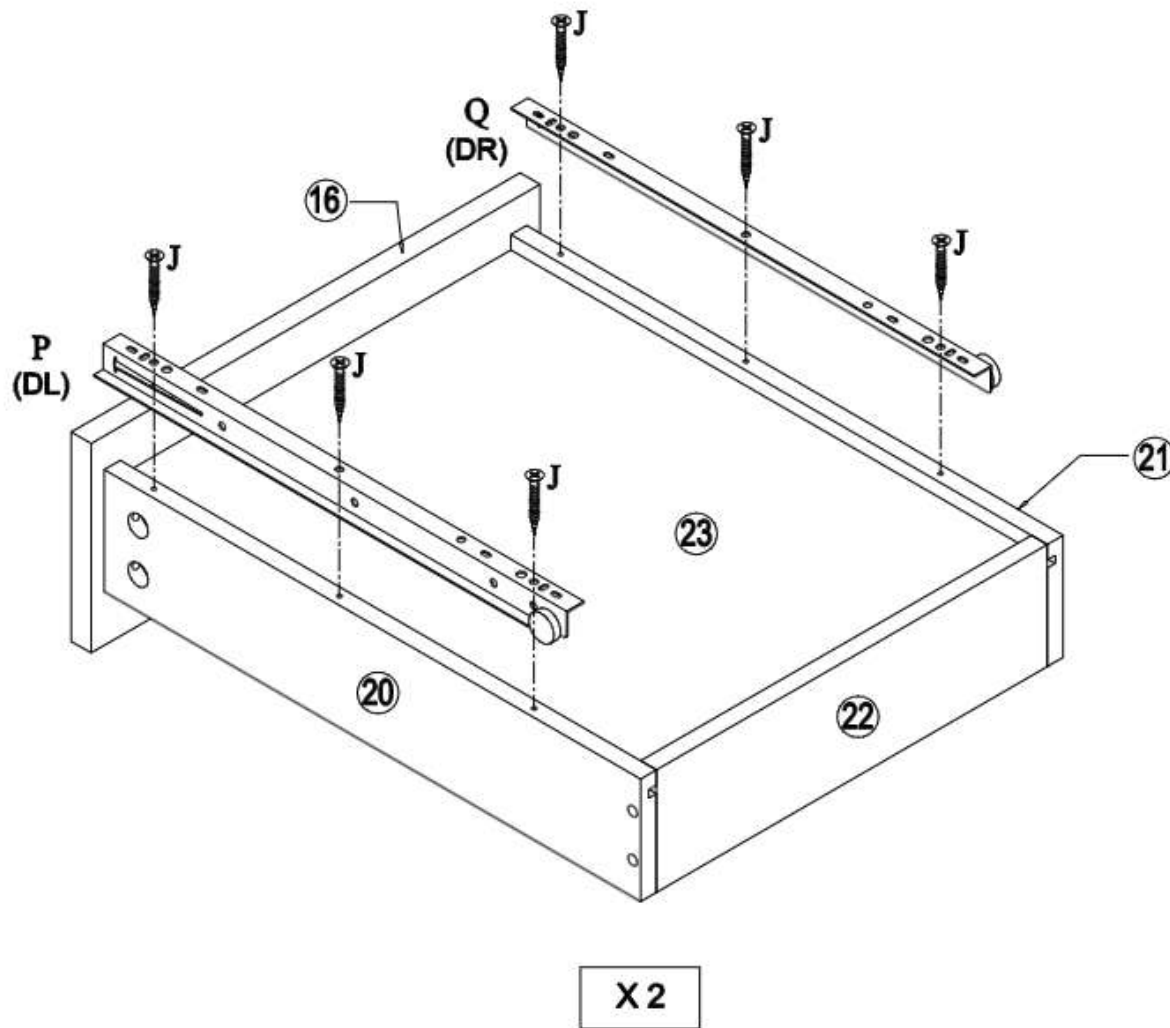

Step 30

I. Attach panel (24) on to panel (20), using screw (D) attach panel (20) to panel (24) with hex key (E) as per diagram.

II. Attach panel (24) on to panel (21), using screw (D) attach panel (21) to panel (24) with hex key (E) as per diagram.

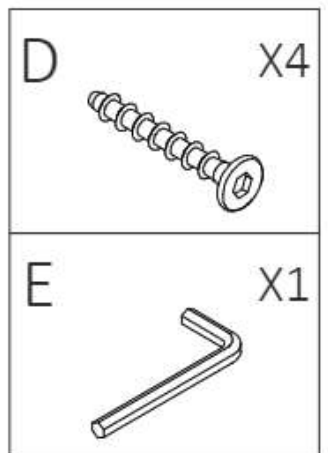
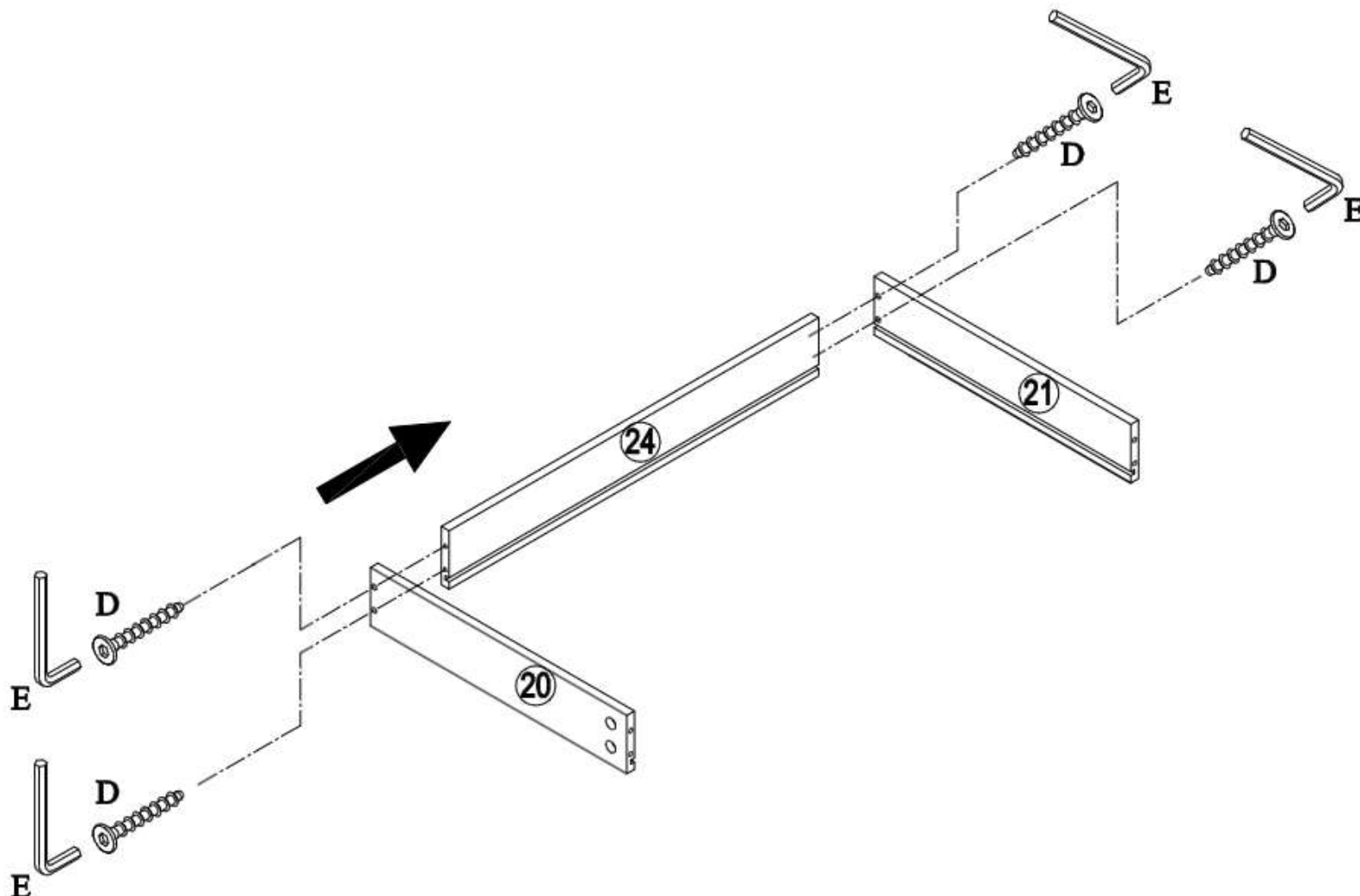

Step 31

I. Place panel (25) as per diagram.

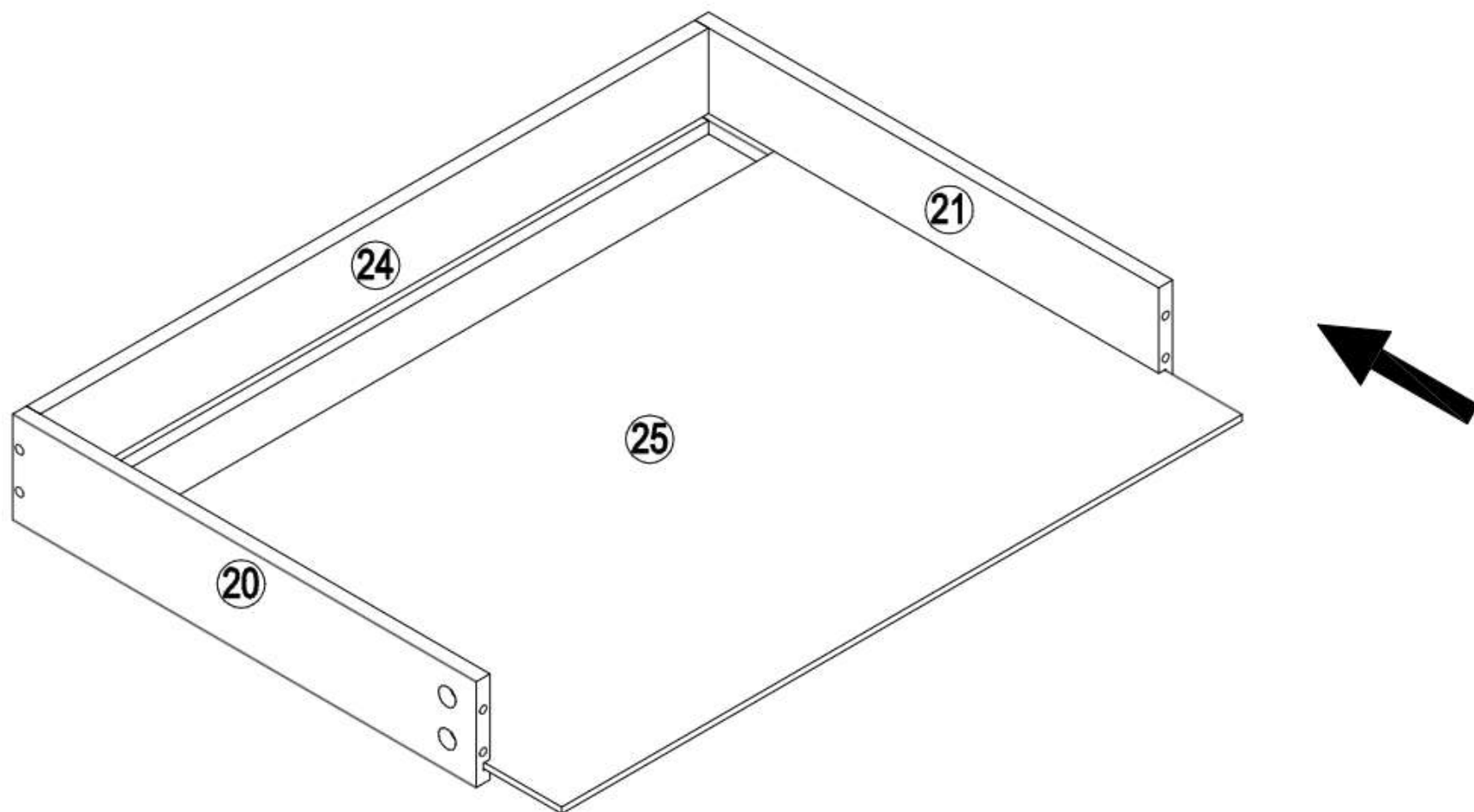

Step 32

I. Attach panel (17) to panel (20,21), insert cam-lock (B) into the panel (20,21), then turn clockwise to lock onto cam-bolt.

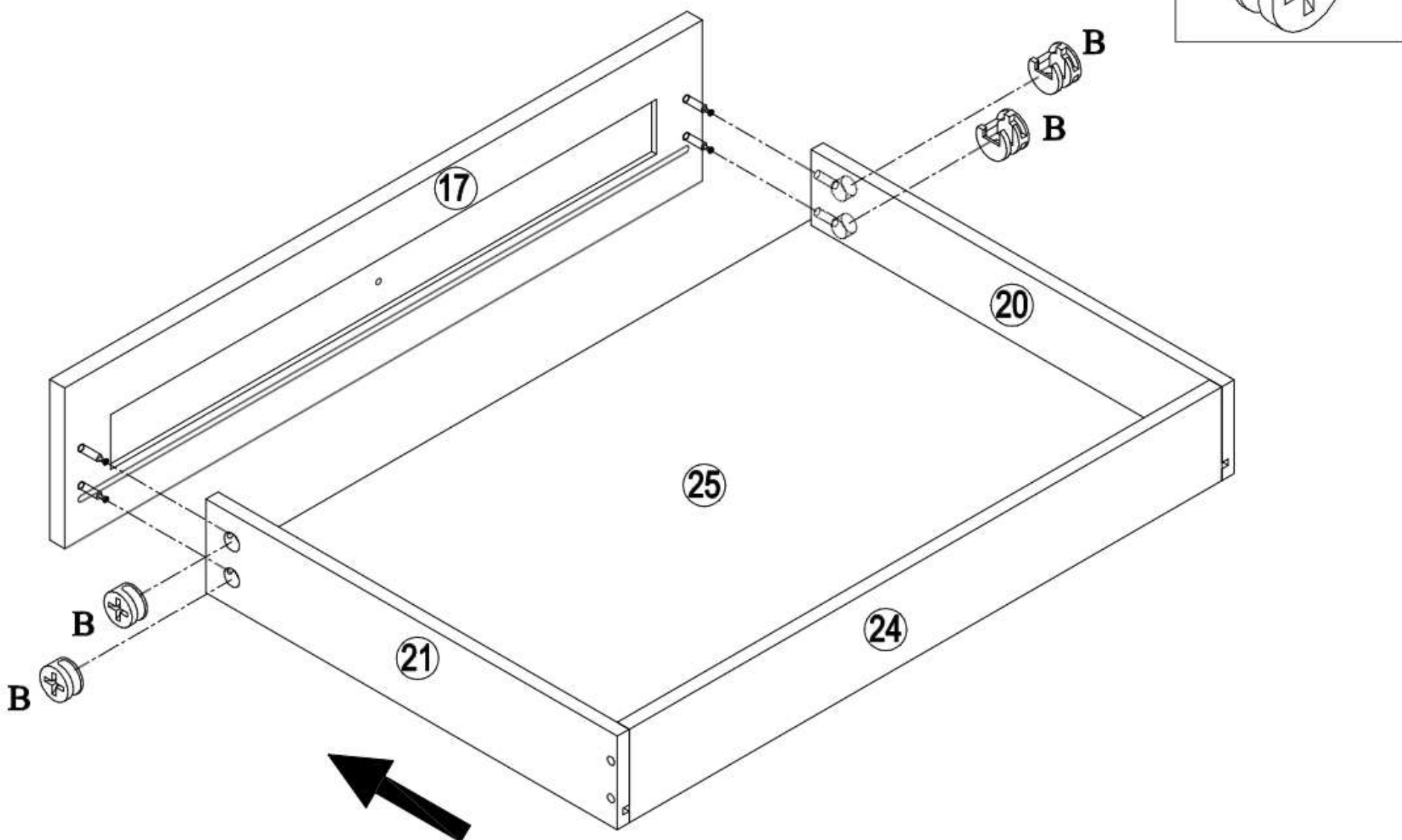

Step 33

I. Using screw (J) secure slide rail DL (P) to panel (20) with screwdriver tighten.

II. Using screw (J) secure slide rail DR (Q) to panel (21) with screwdriver tighten.

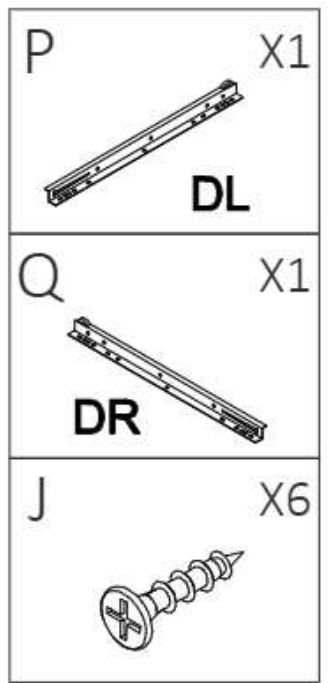
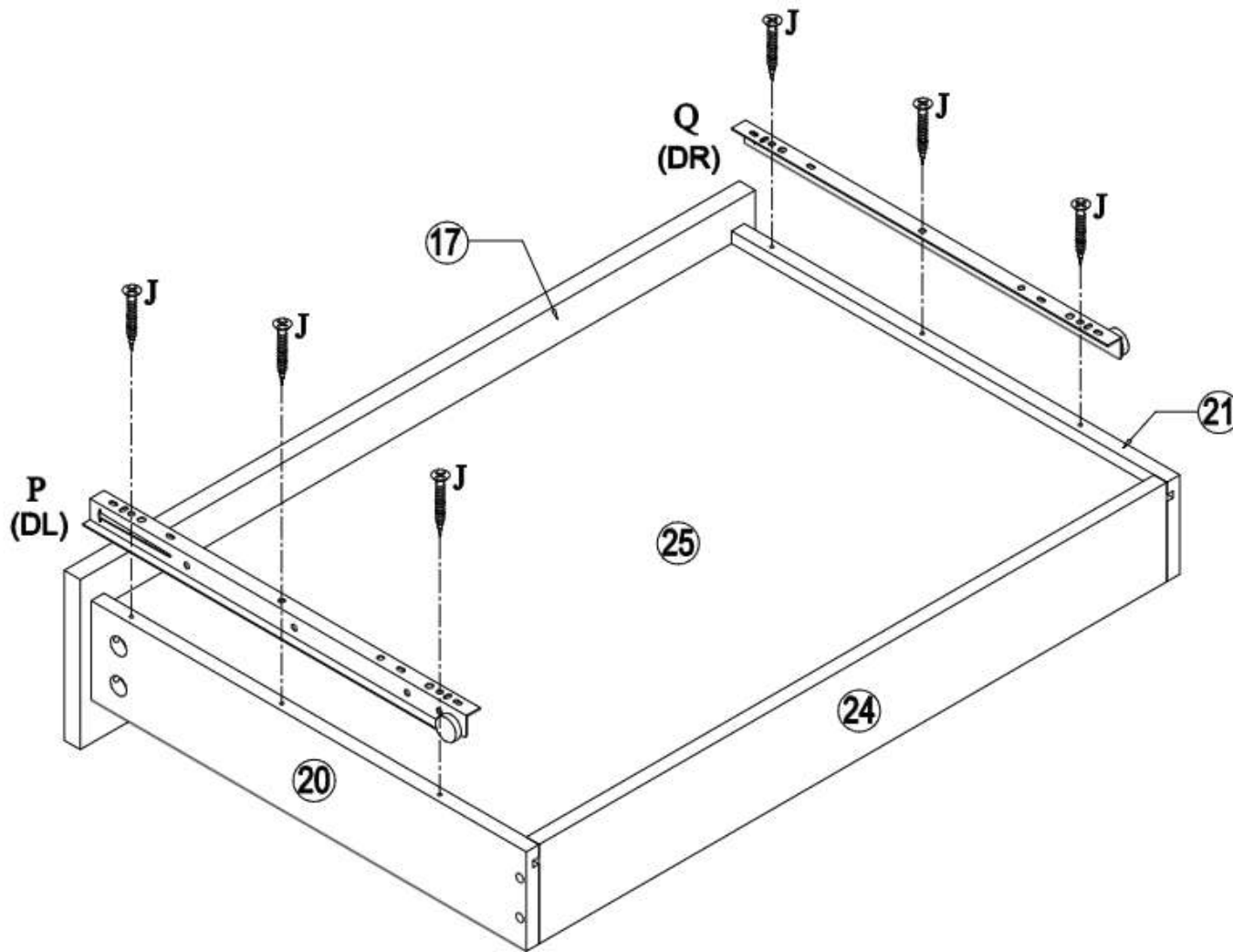

Step 34

I. Attach panel (28) on to panel (26), using screw (D) attach panel (26) to panel (28) with hex key (E) as per diagram.

II. Attach panel (28) on to panel (27), using screw (D) attach panel (27) to panel (28) with hex key (E) as per diagram.

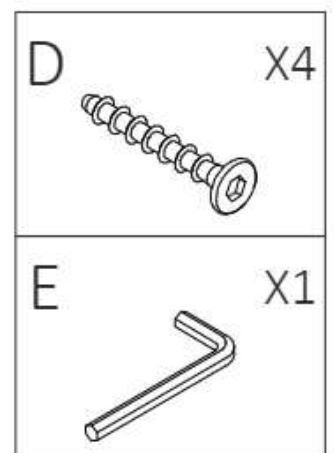
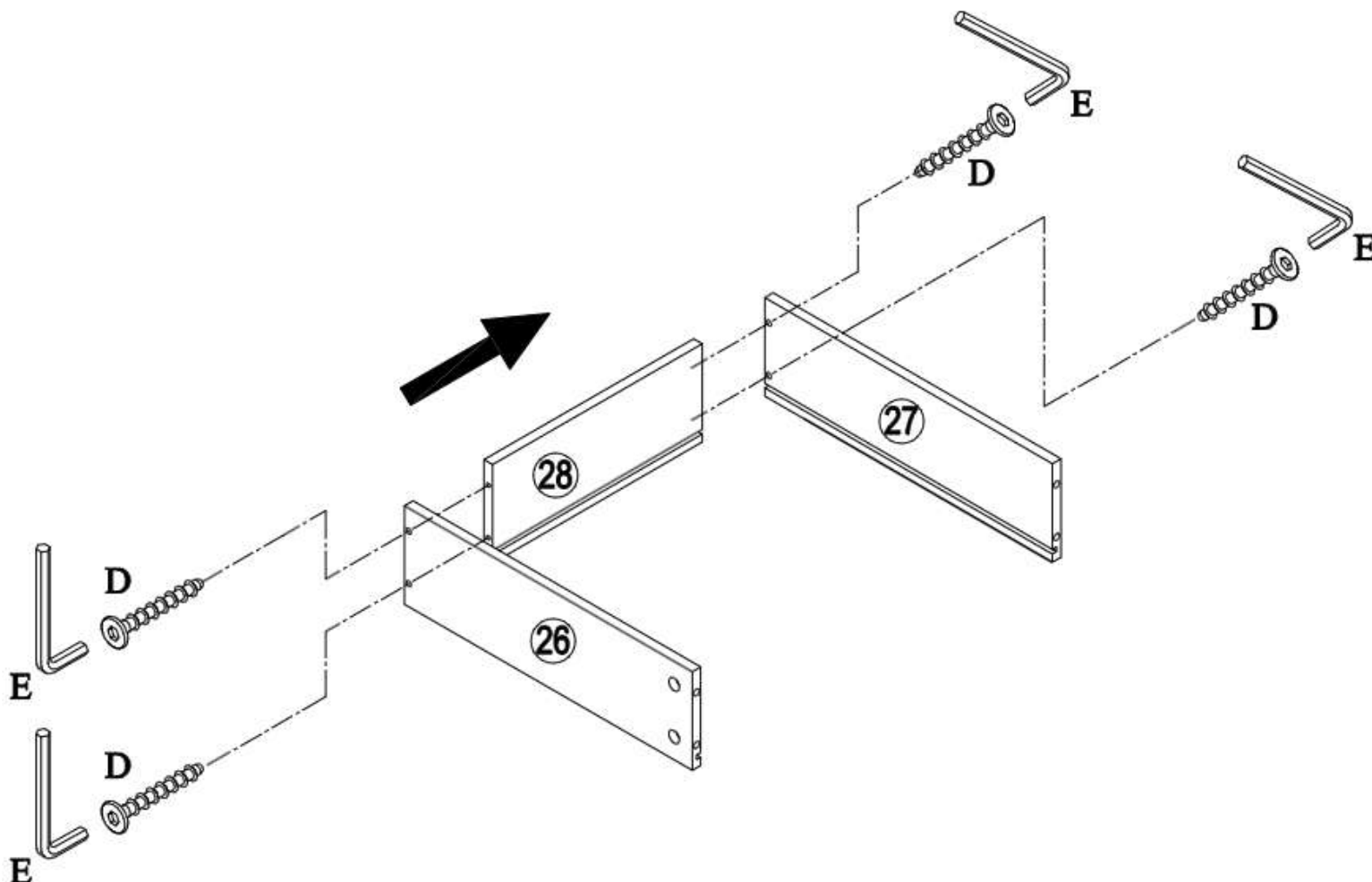

Step 35

I. Place panel (23) as per diagram.

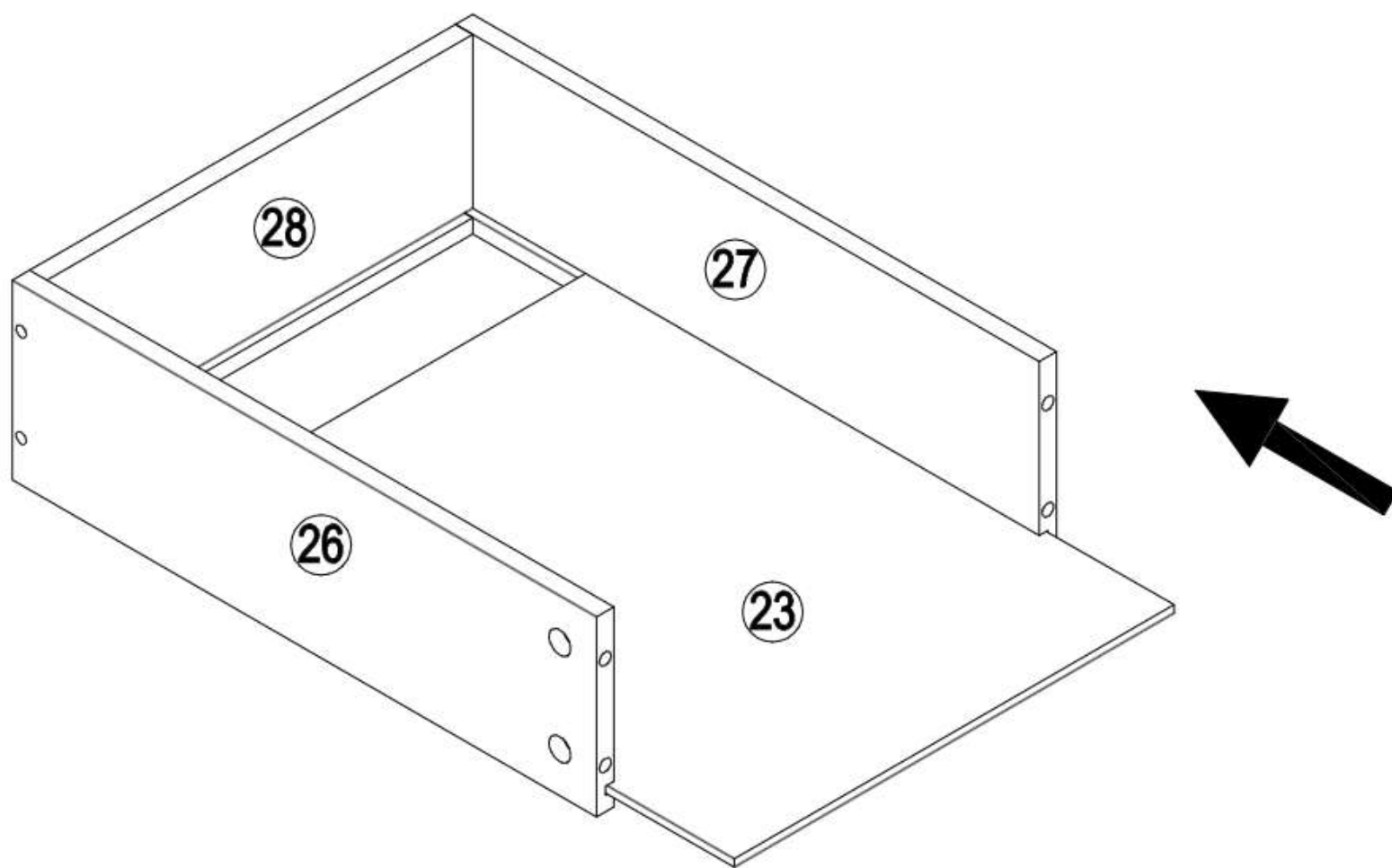

Step 36

I. Attach panel (18) to panel (26,27), insert cam-lock (B) into the panel (26,27), then turn clockwise to lock onto cam-bolt.

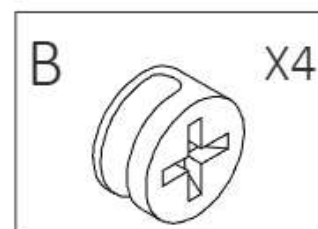
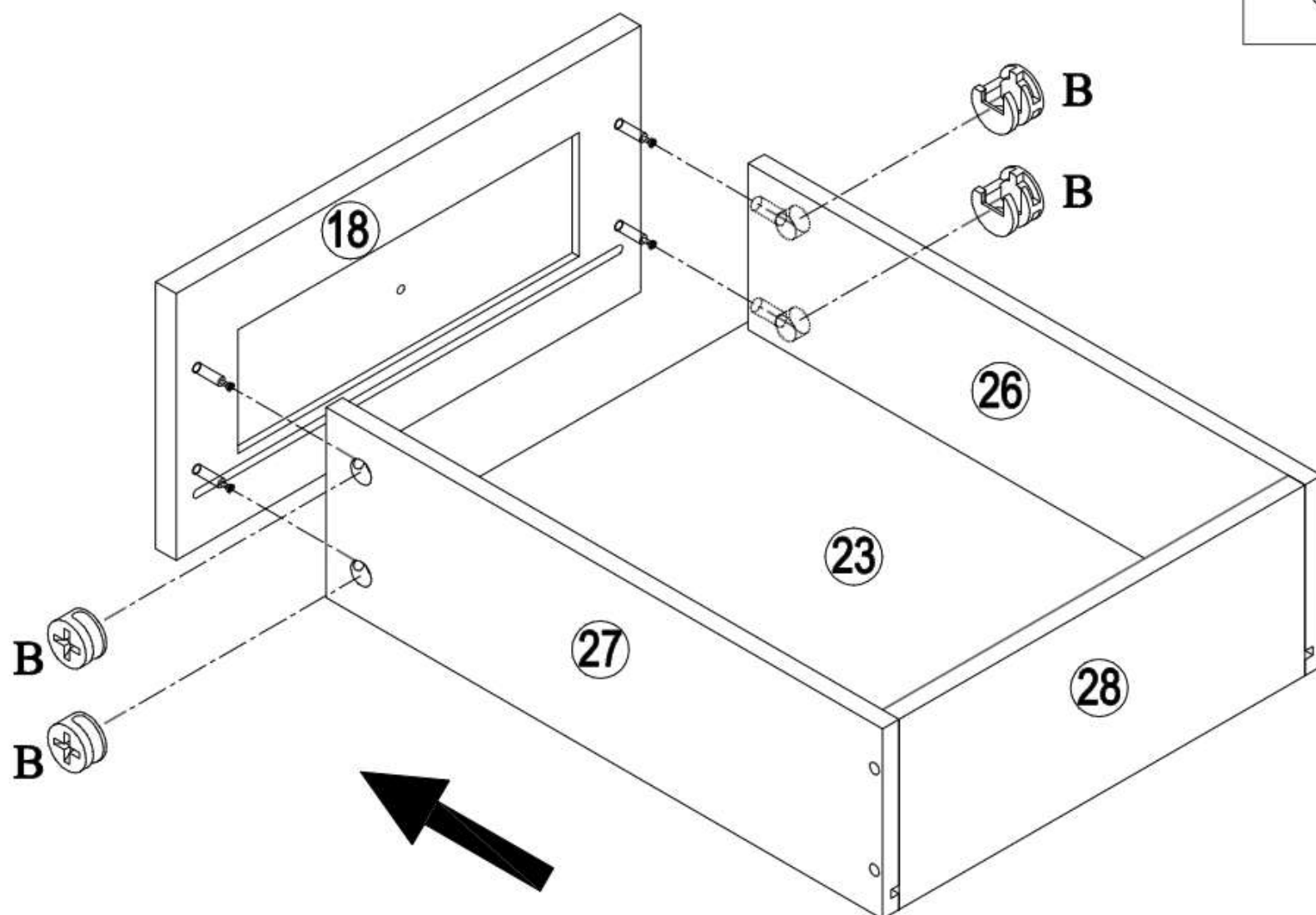

Step 37

I. Using screw (J) secure slide rail DL (P) to panel (26) with screwdriver tighten.

II. Using screw (J) secure slide rail DR (Q) to panel (27) with screwdriver tighten.

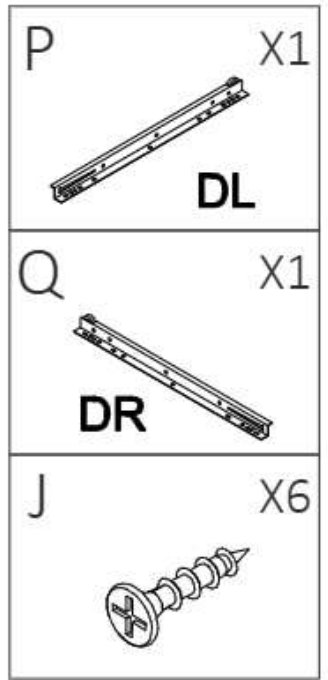
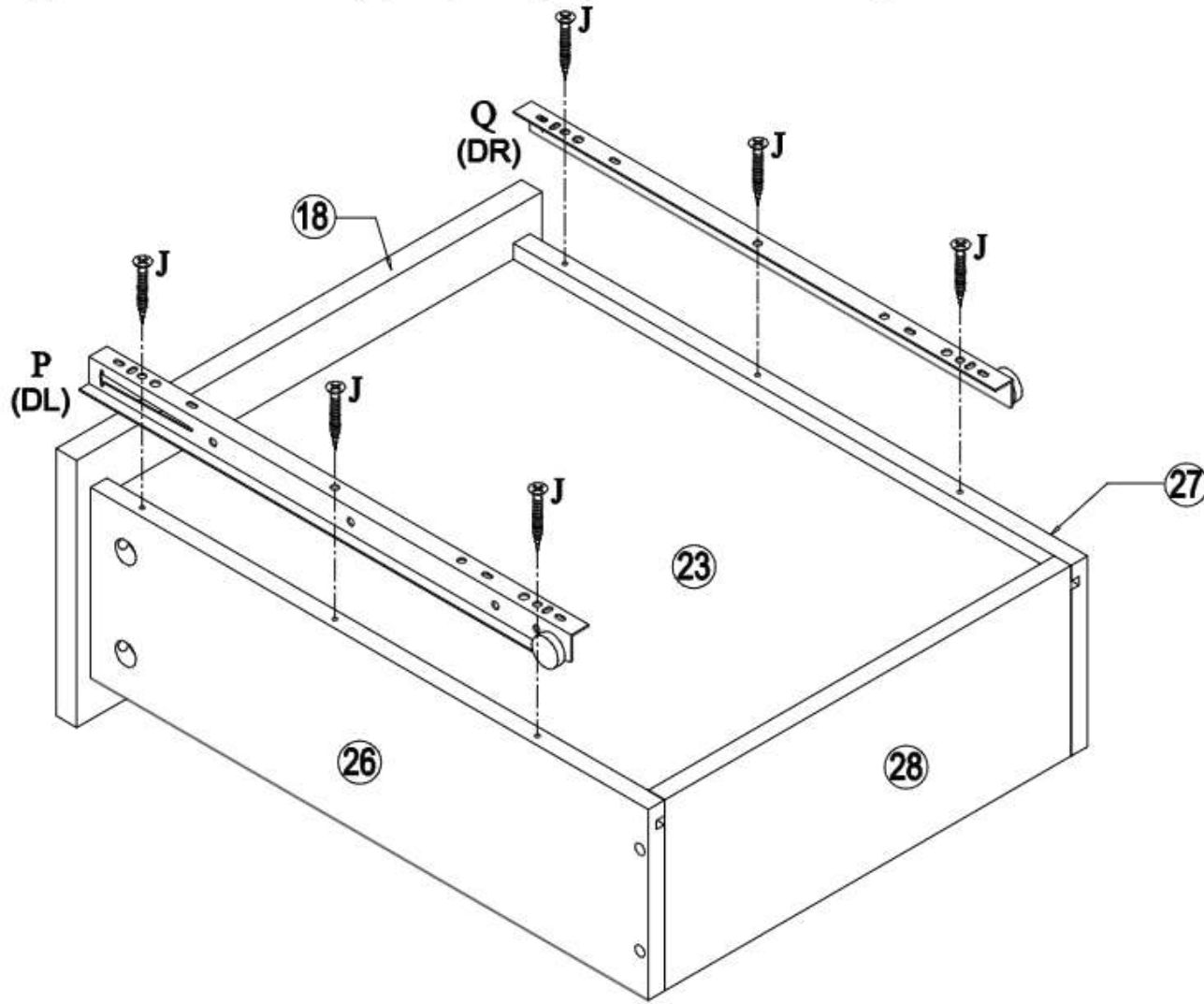

Step 38

I. Attach panel (31) to panel (29,30), using screw (D) attach panel (31) to panel(29,30) with hex key (E) as per diagram.

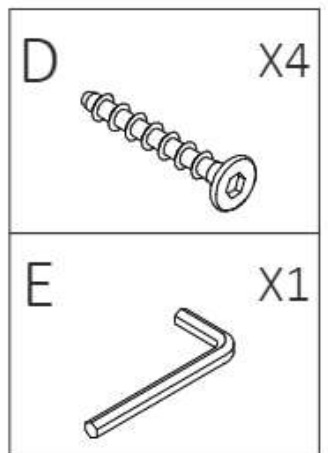
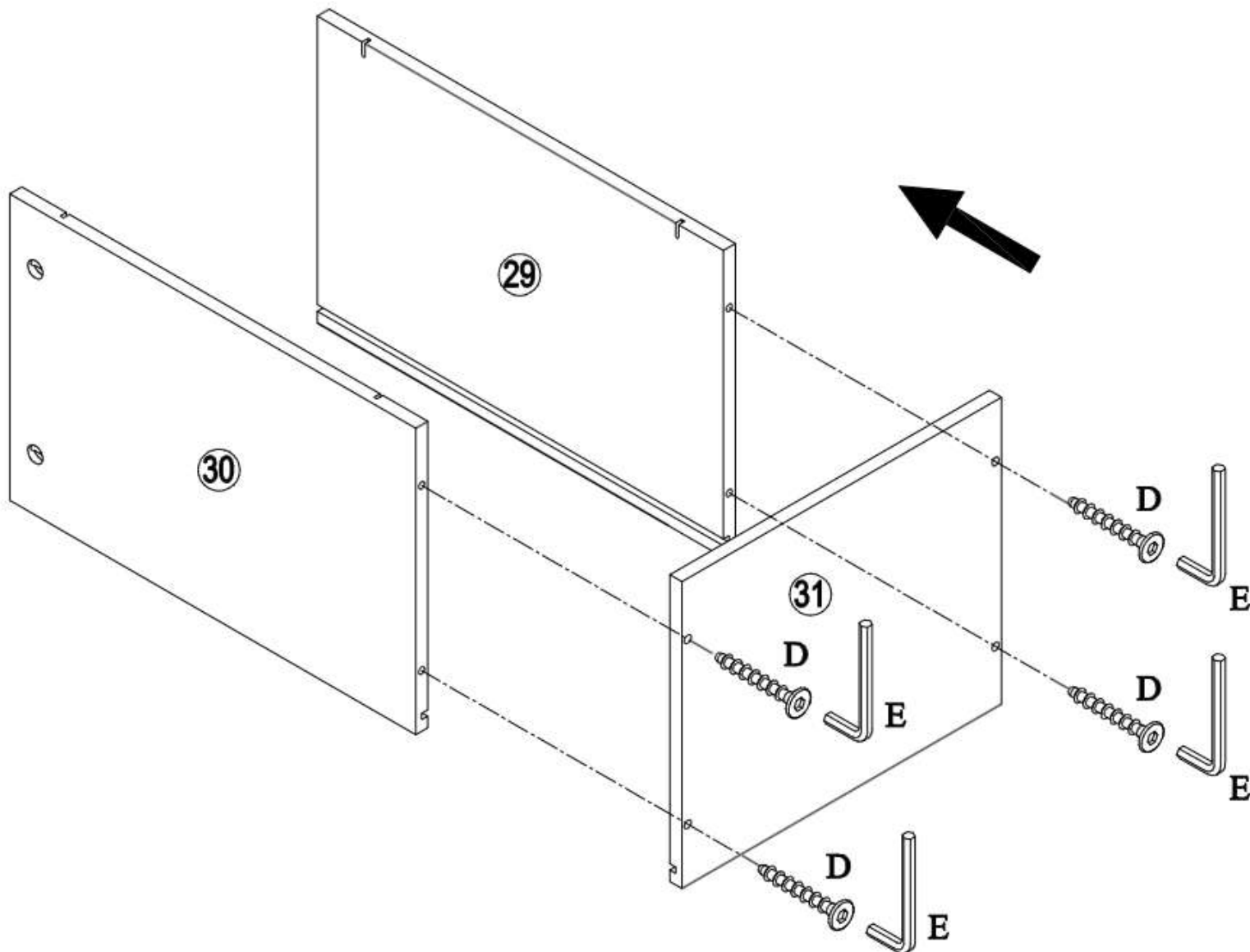

Step 39

I. Place panel (32) as per diagram.

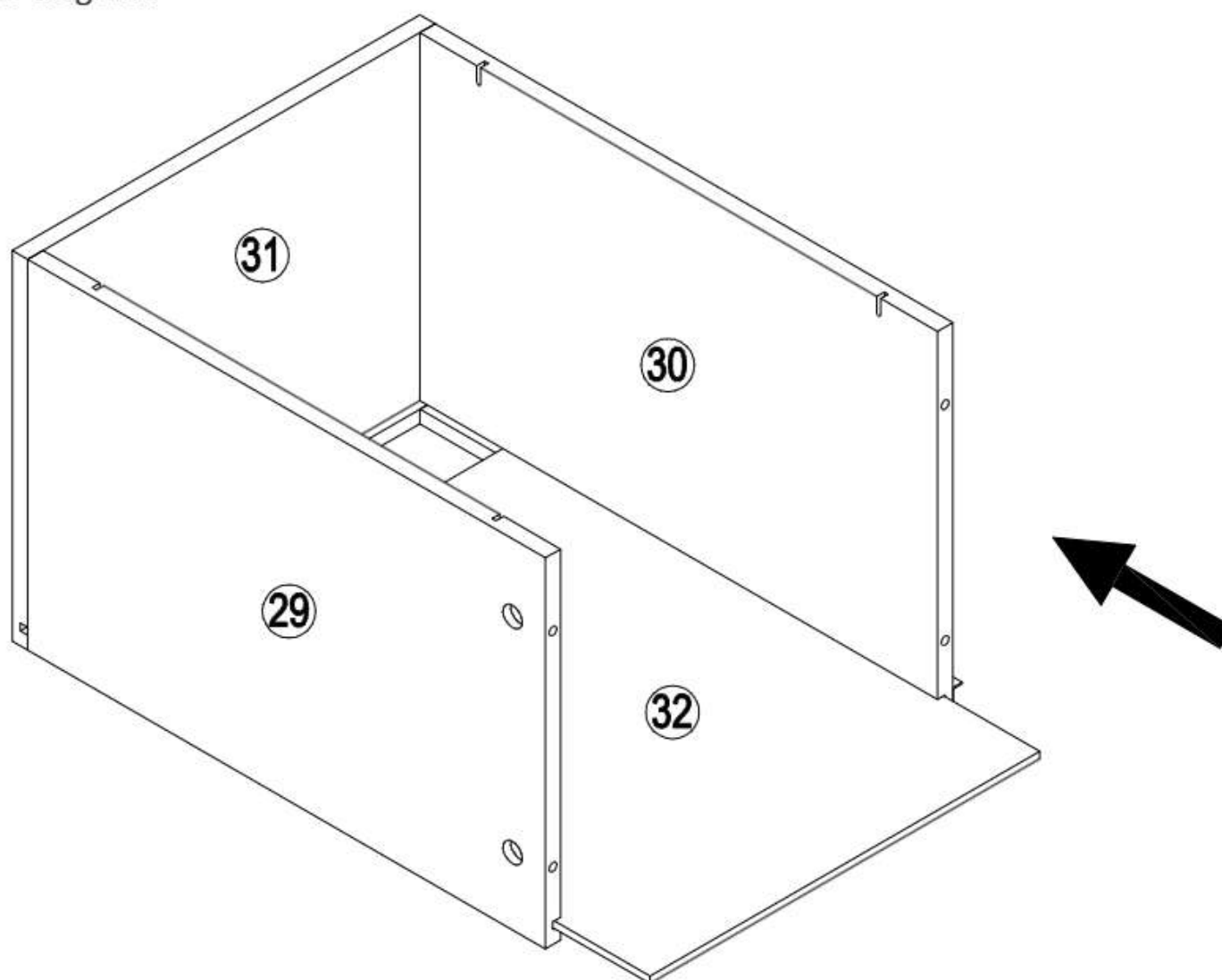

Step 40

I. Attach panel (19) to panel (29,30), insert cam-lock (B) into the panel (29,30), then turn clockwise to lock onto cam-bolt.

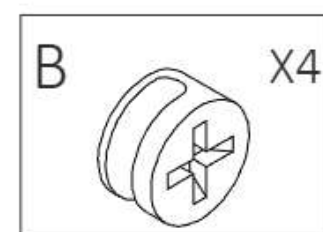
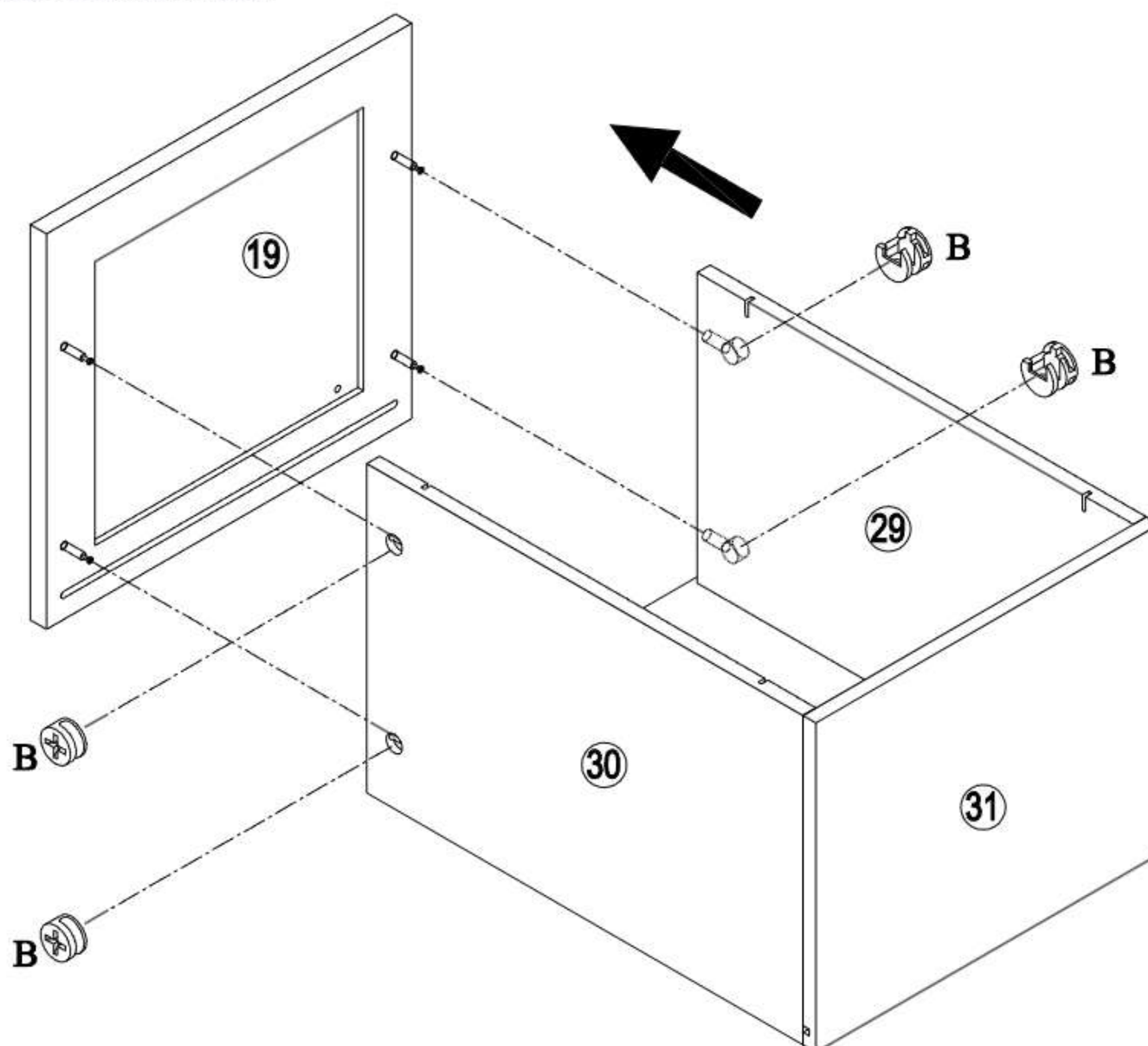

Step 41

I. Using screw (J) secure slide rail DL (P) to panel (29) with Screwdriver tighten.

II. Using screw (J) secure slide rail DR (Q) to panel (30) with screwdriver tighten.

Note Slide rail needs to distinguish between left and right and direction

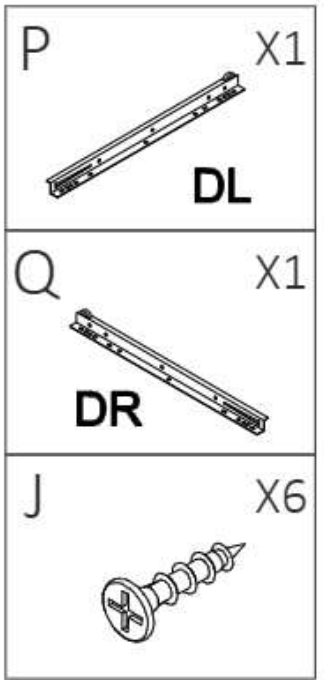
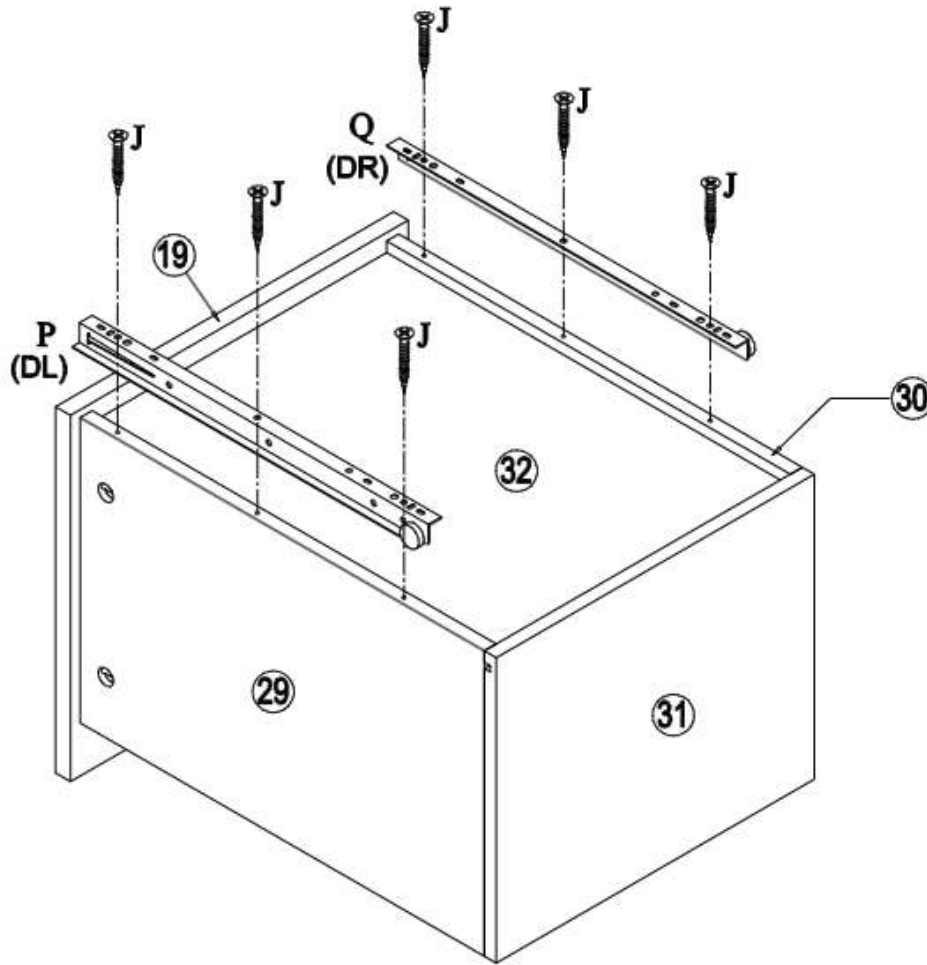

Step 42

I. Place file support shelf (M) on panel (29,30) as per diagram.

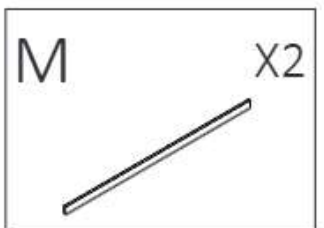
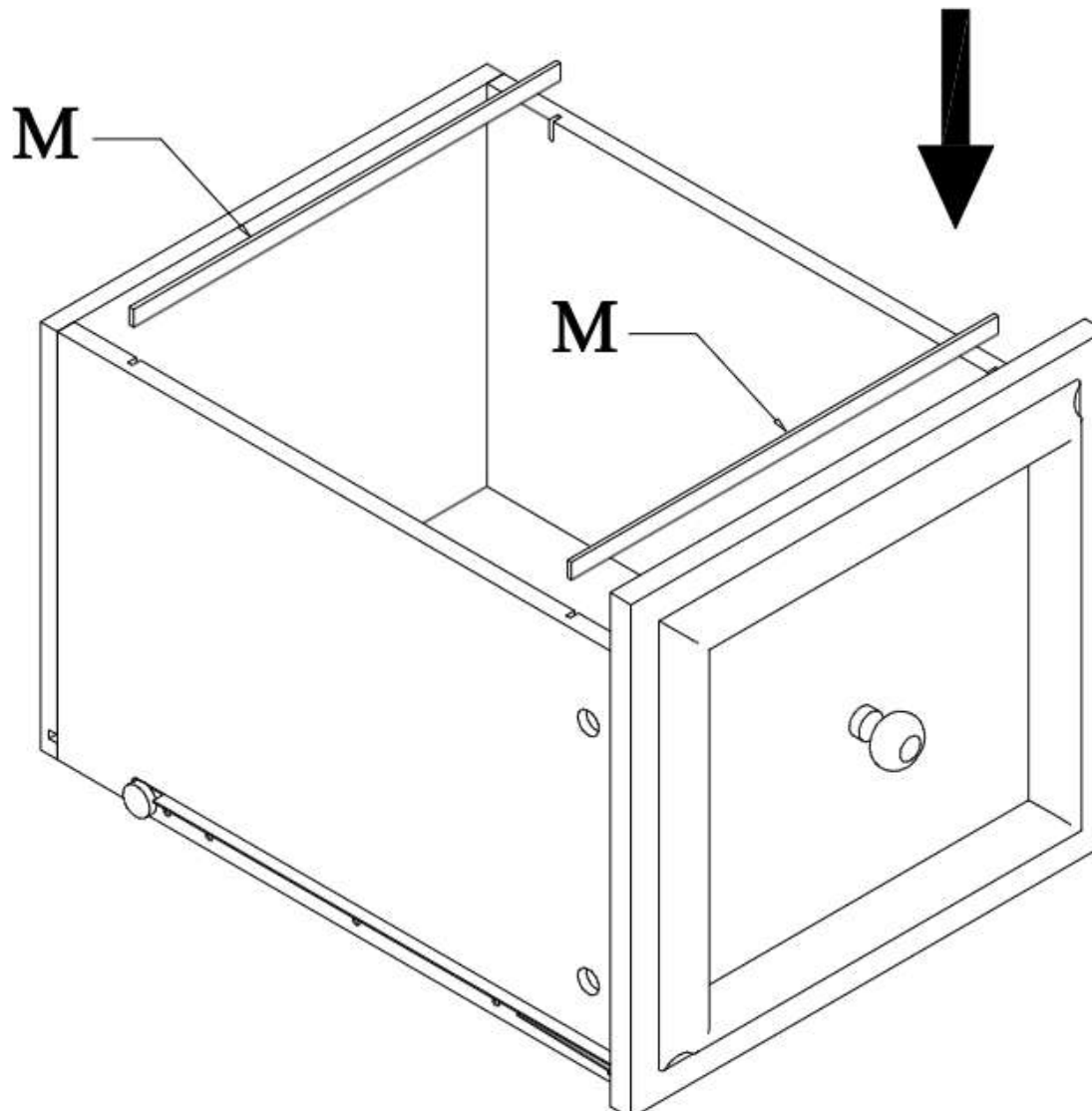

Step 43

I. Place drawers as per diagram.

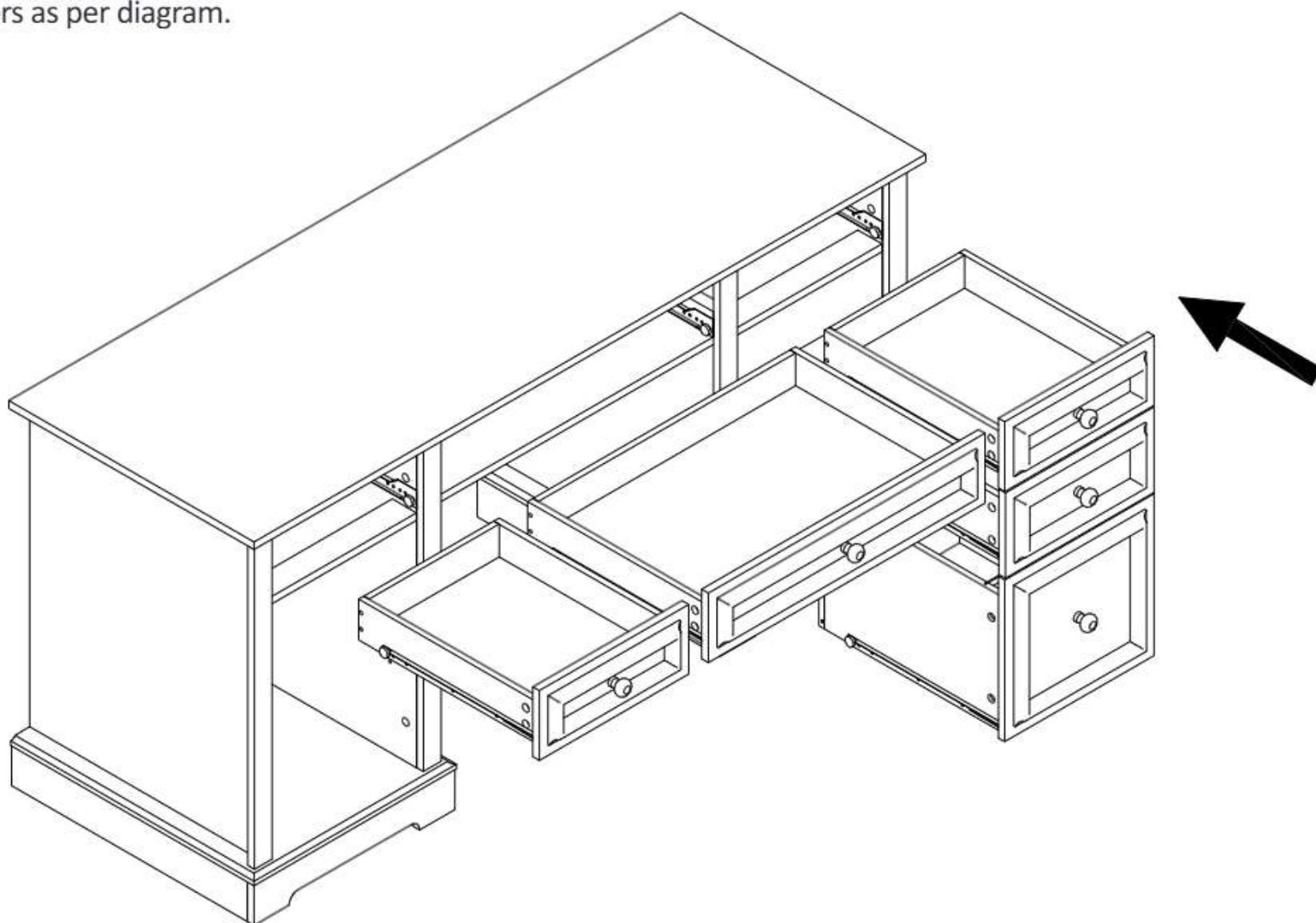

Step 44

I. Insert shelf support pin (F) into panel (7,8) as per diagram.

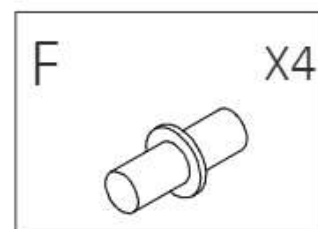
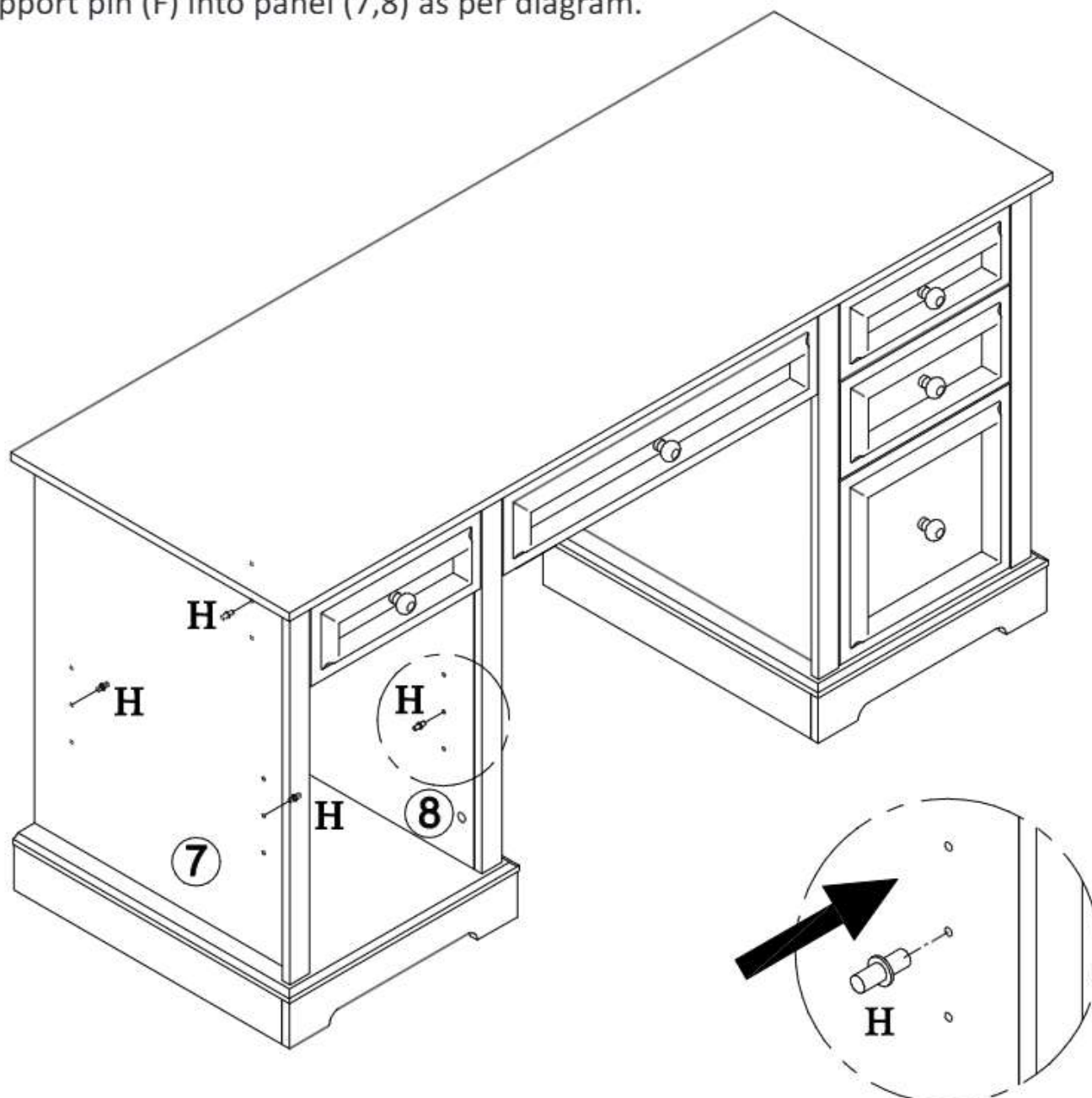

Step 45

I. Put the adjustable panel (34) on to the shelf support pins.

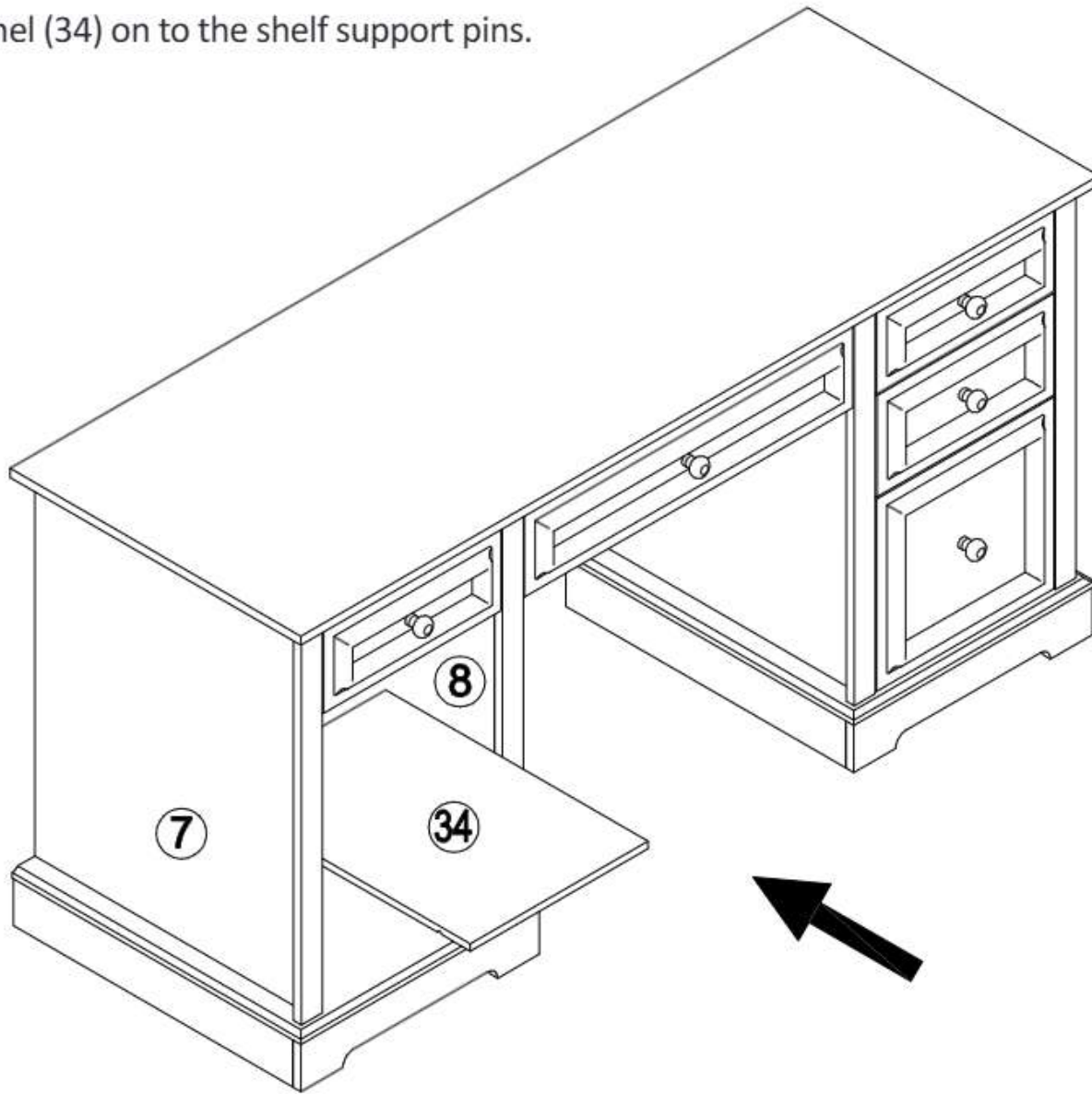

Step 46

I. Using screw (J) attach hinge (I) to panel (33) with screwdriver.

II. Using screw (G) secure handle (F) to panel (33) with screwdriver as per diagram.

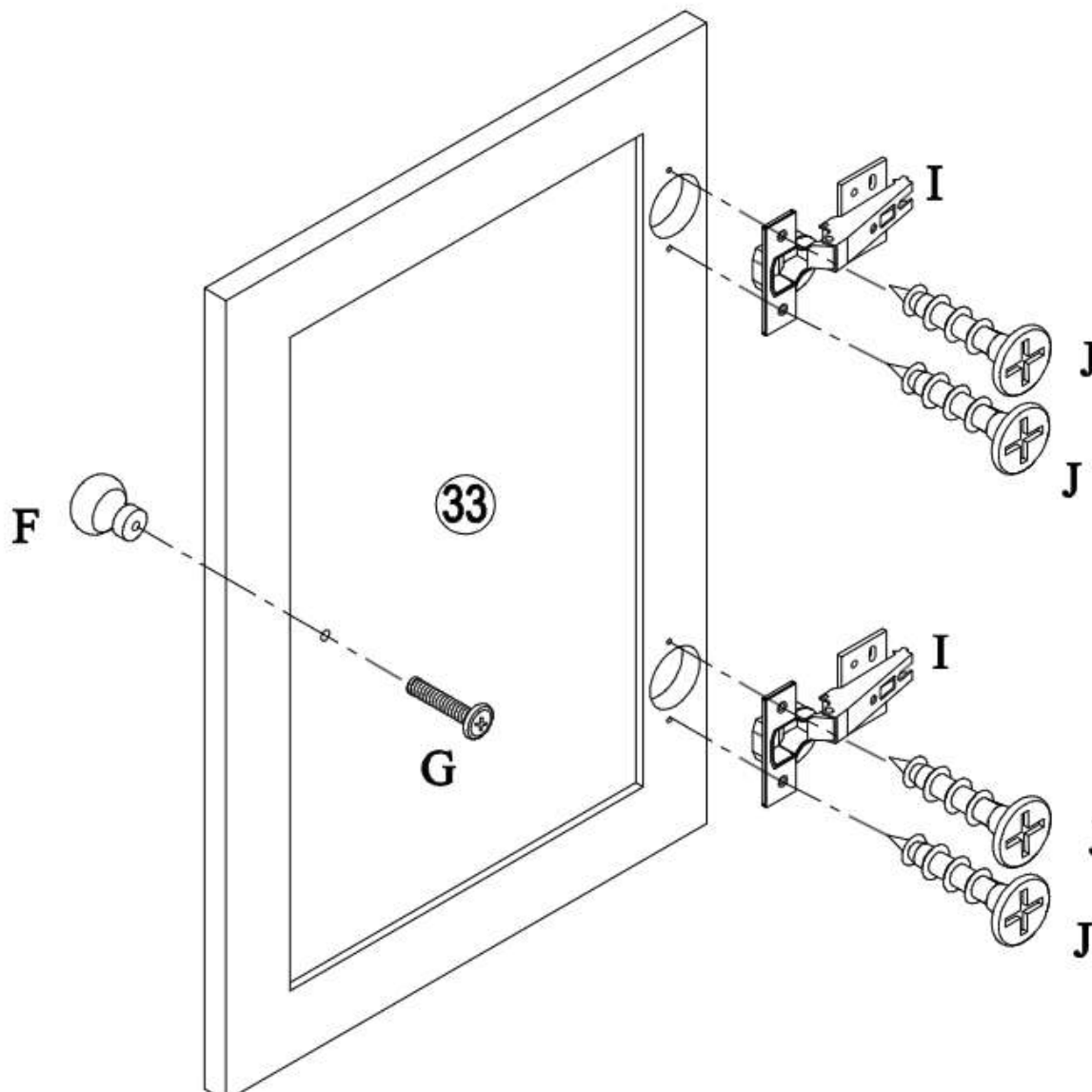

F	X1	
G	X1	
I	X2	
J	X4	

Step 47

I. Using screw (J) attach hinge (I) on panel (34) to panel (7) with head screwdriver.

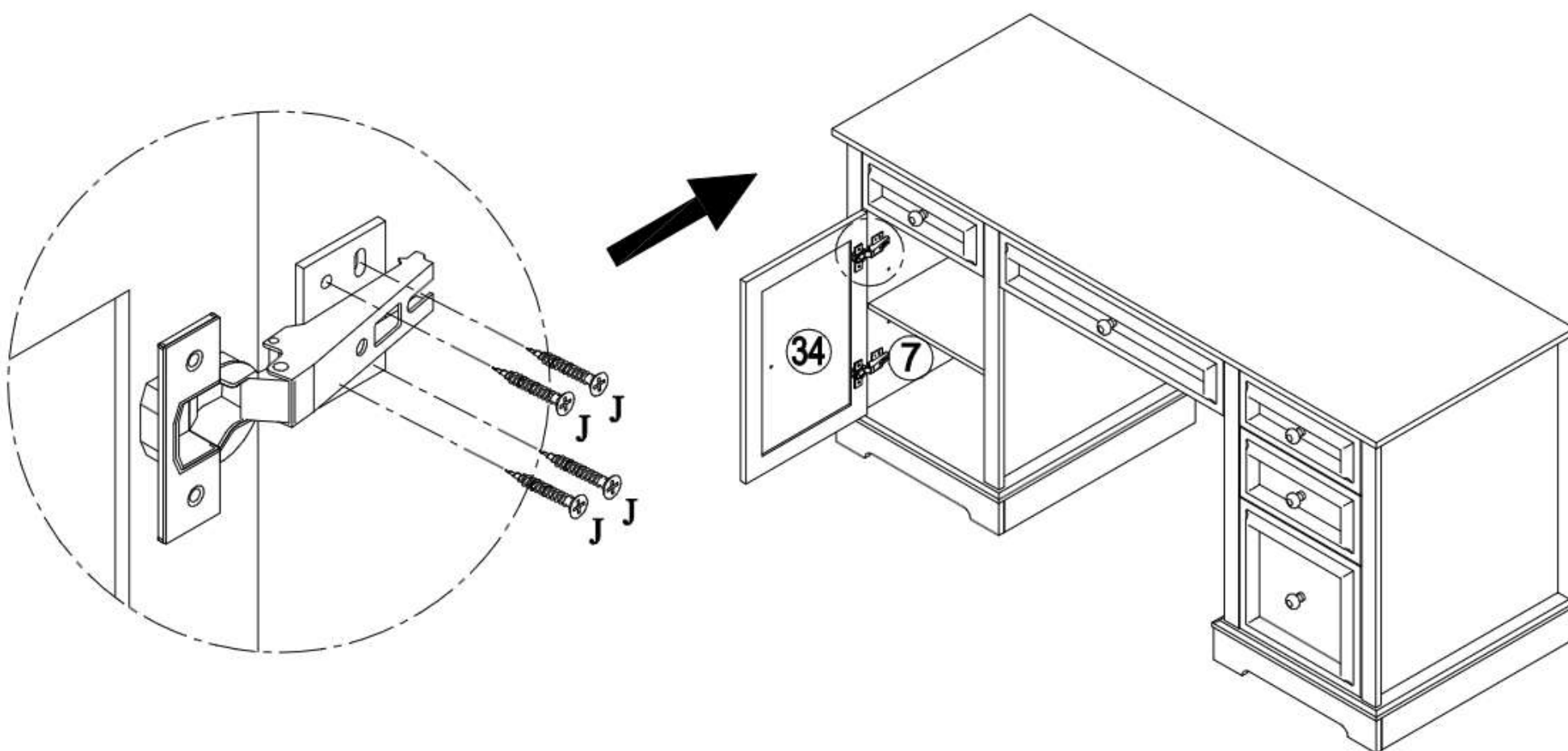
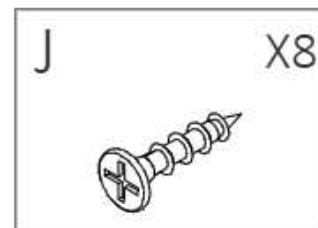

Step 48

I. Using screw (L) attach plastic wedge (K) to panel (12,12) with screwdriver as per diagram.

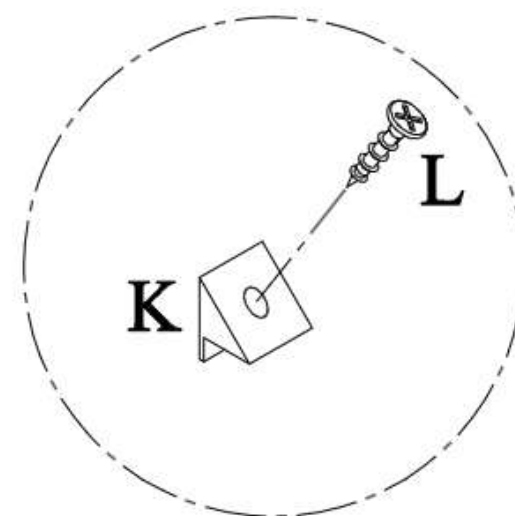
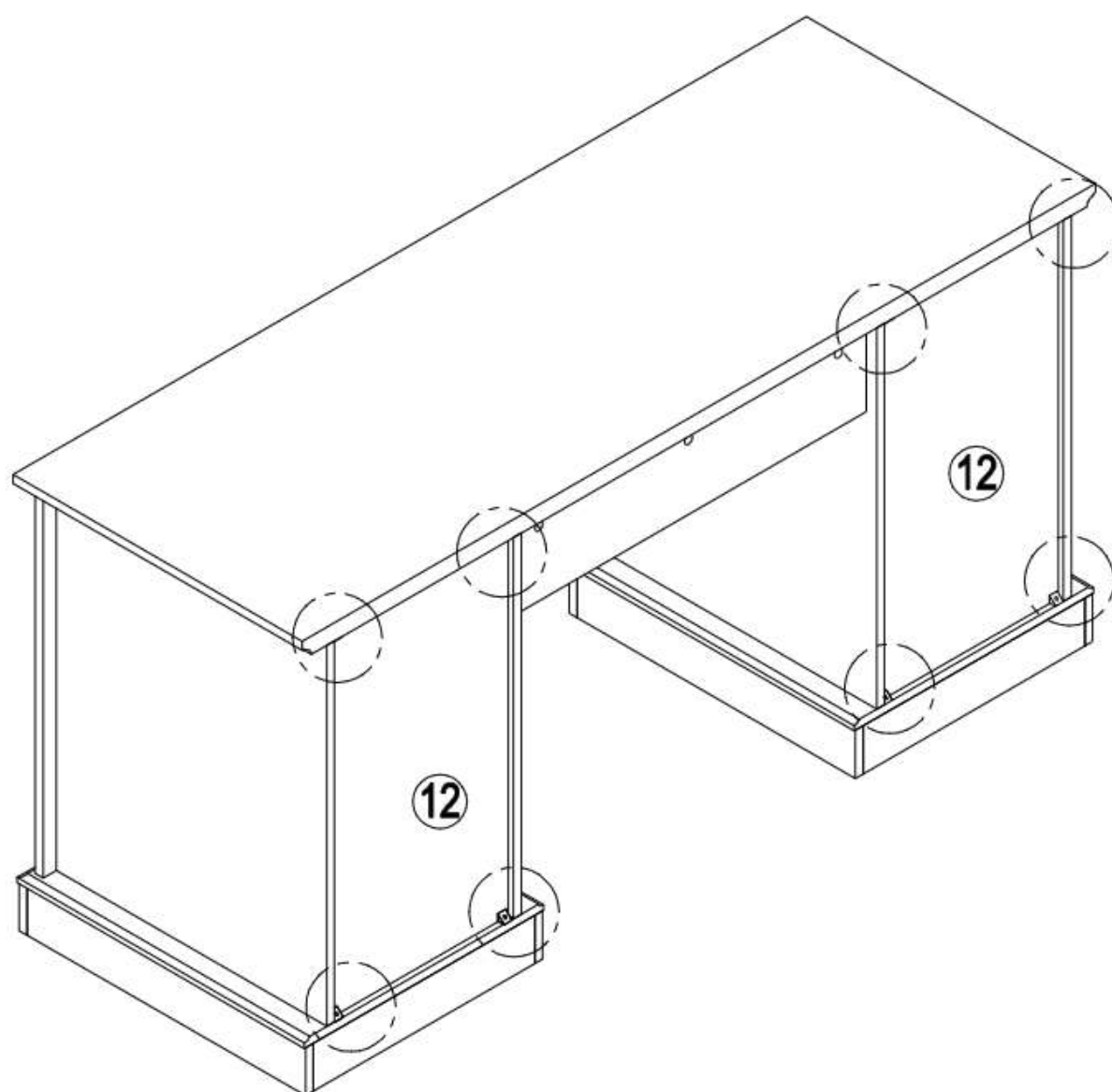
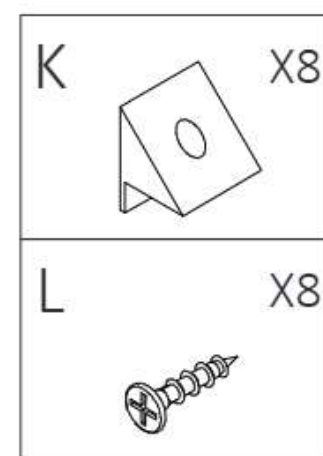

The ways to adjust the door

- Before adjusting the hinge, please check whether the cabinet is skewed.
- If the skew can not be repaired, please remove the anti-tipping device first, then adjust the cabinet to vertical position.
- Please adjust the hinge with the door open.
- Please operate it with more than 2 people, one person holds the door and the other one adjusts the screw.

Components Name

The door side

The cabinet side

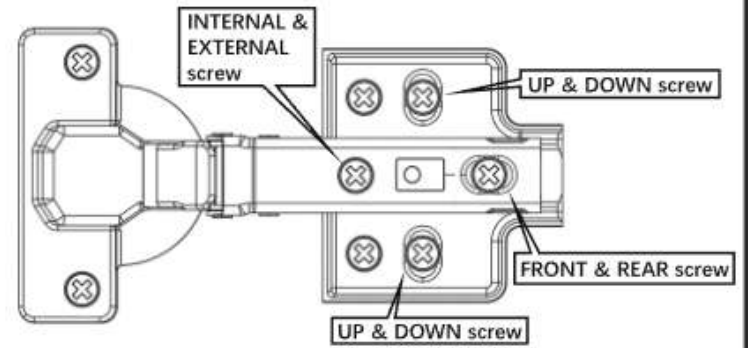

When door is crooked



Please take the following steps to adjust first.

1 Rotate the "front and rear screws" to the left

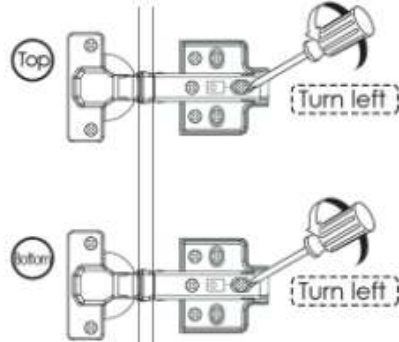

2 Push the door to the cabinet

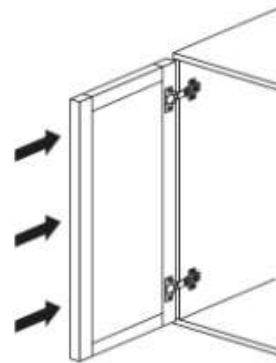

3 Rotate the "front and rear screws" to the right

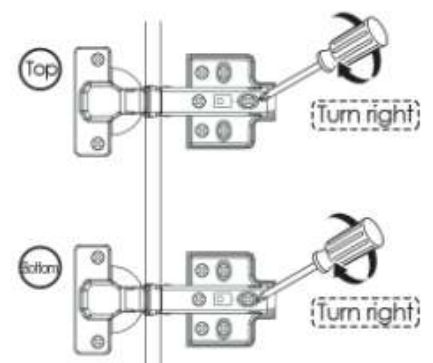

※ After adjusting the "front and rear screw", the door still does not change, please turn the "internal & external screw" to the right slightly.

When door is leaning

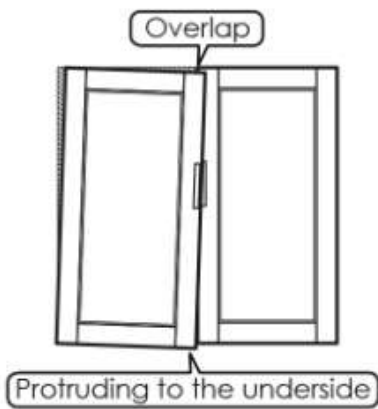

1 Turn "internal & external screw" to the left can make the top of the door tilted outward.

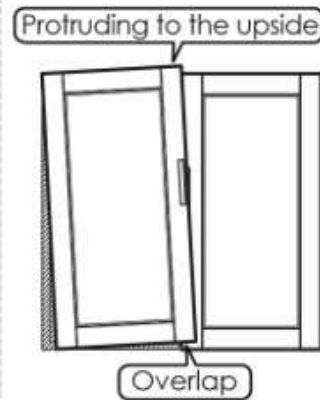
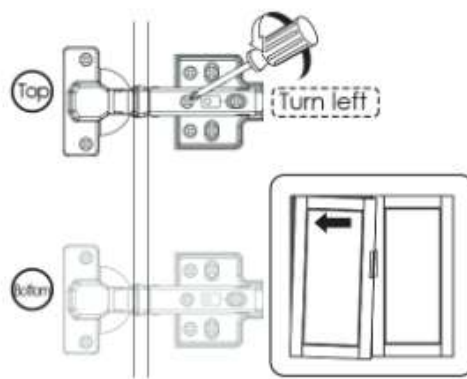

1 Turn "internal & external screw" to the left can make the bottom of the door tilted outward.

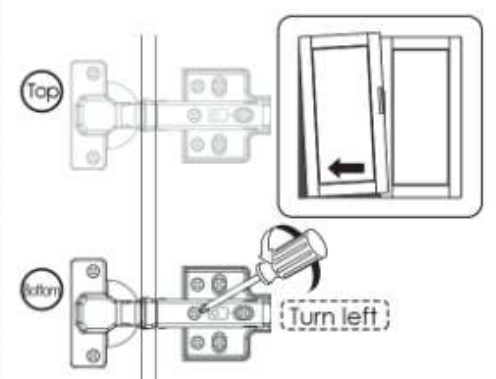

When 2 doors are not tight

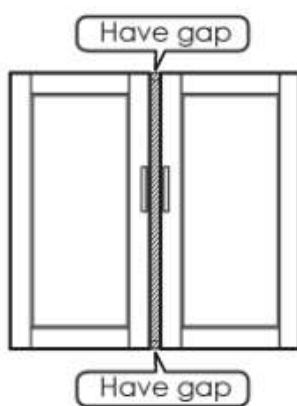

1 Turn "internal & external screw" to the right can make the door approach inside. Please adjust the doors little by little.

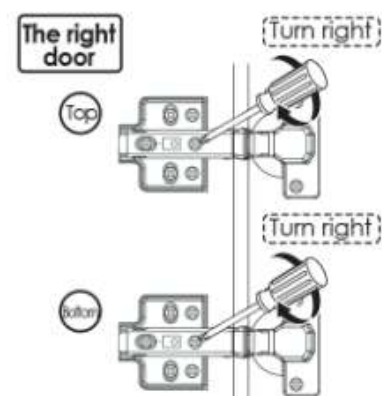
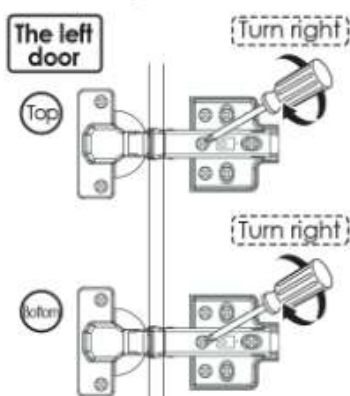

※ If the 2 doors are overlap, please turn the "internal & external screw" to the left.

When the door is higher on top

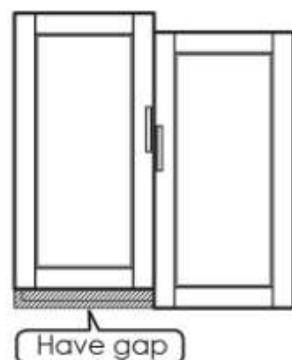

1 Turn "up & down screw" to the left

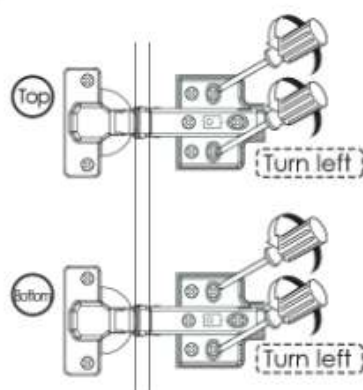

2 Lower the door's height so that 2 doors are of the same height.

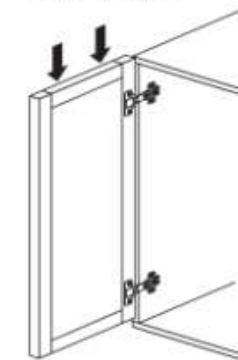

3 Turn "up & down screw" to the right

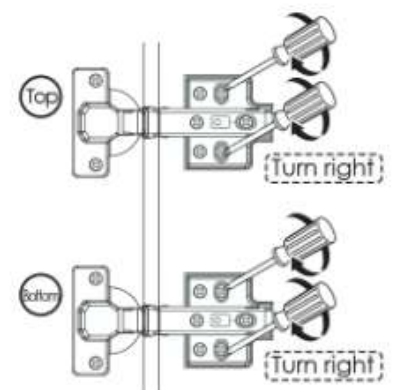

※ If the door is lower on bottom, please lift up the left door slightly on step 2