

Cabinet

Assembly Instruction - Please keep properly for future reference.

If you find any missing boxes, damaged parts, or accessory shortages, please contact the customer service team of your purchasing channel immediately. We will resolve the issue as quickly as possible.

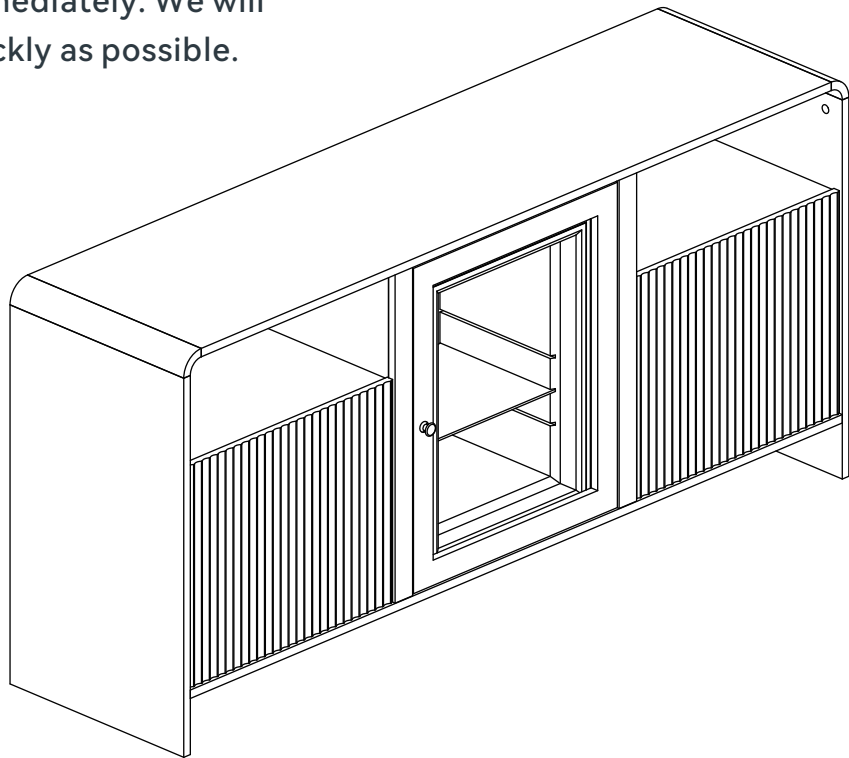

Dimensions

Width-59.8 inch
Depth-15.7 inch
Height-28.2 inch

EN

THE FOLLOWING INFORMATION:

- Order number
- Purchase platform
- Purchase date
- Detailed description of the issue along with photos (if applicable)

Important - Please read these instructions carefully before starting the installation.



Safety and Care Advice

Important – Please read these instructions fully before starting assembly

- Check you have all the components and tools listed on the following pages.
- Remove all fittings from the plastic bags and separate them into their groups.
- Keep children and animals away from the work area, small parts could choke if swallowed.
- Make sure you have enough space to layout the parts before starting.

- During assembly do not stand or put weight on the product, this could cause damage.
- Assemble the item as close to its final position (in the same room) as possible.
- Assemble on a soft level surface to avoid damaging the unit or your floor.
- Parts of the assembly will be easier with 2 people.

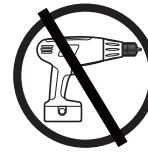

- To reduce the likelihood of damaging your product please ensure that your power drill is set on a low torque setting.

Care and maintenance

- Only clean using a damp cloth and mild detergent, do not use bleach or abrasive cleaners.
- From time to time check that there are no loose screws on this unit.
- This product should not be discarded with household waste. Take to your local authority waste disposal centre.

Handy Hints

- Assemble all parts and bolts loosely during assembly, only once the product is complete should you fully tighten the bolts
- Regularly check and ensure that all bolts and fittings are tightened properly.

WARNING In order to help prevent overturning – please follow these instructions

To help prevent product toppling over please follow the below steps:-

Use the anti tip strap or wall fixing method provided (if applicable)
Do not allow children to climb or hang on the furniture
Do not open more than one drawer at a time
Do not place heavy items in the top drawers
Do not place heavy items on top of the furniture, unless the furniture has been designed for this purpose

Please note that only the anti tip strap is provided.
You will need to provide wall plugs and screws applicable for your wall type

CUSTOMER SERVICE GUIDE

Thank you for choosing our product! We are committed to providing you with excellent service. If you find any missing parts, damaged packaging, or product damage after receiving all packages, please follow the steps below to quickly contact our customer service team. We will do our best to resolve your issue.

1. Missing Parts

Verify Parts:

1. Refer to the “Parts List” in the manual to verify the name, specifications, and quantity of the missing parts.
2. Take a clear photo of the parts list and mark the missing parts with detailed information, e.g., “Missing 5 pieces of M6x30mm screws.”

Contact Us:

- A description of the missing parts and a photo of the parts list.
- Order details (order number, purchase platform, purchase date).

2. Product or Packaging Damage

If it affects normal use:

Steps:

Take clear photos or videos showing the damaged parts and the extent of the damage (multi-angle shots are recommended).

Resolution:

After verification, we will arrange for a replacement part, product exchange, or refund as quickly as possible.

If it does not affect normal use:

Steps:

Provide a description of the damage and include relevant photos or videos.

Resolution:

We will provide repair guidance or an appropriate compensation plan based on the specific situation.

Helpful Tips

To process your issue efficiently, please prepare the following information:









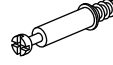

- Order details (order number, purchase platform, purchase date).
- Clear photos or videos.
- We are committed to providing quick and professional solutions, no matter the size of the issue, to ensure your satisfaction.

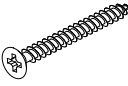
Thank you for your trust and support! We hope you enjoy using our product!

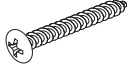
Componets - Fittings

Please check you have all the fittings listed below

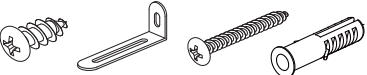
Note: The quantities below are the correct amount to complete the assembly. In some cases more fittings may be supplied are required.

A  6*30mm Wooden Dowel x 40	B  6*35mm Cam Bolt x 46	C  Cam Lock x 46
D  4*40mm Screw x 4	E  2.5*12mm Screw x 42	F  4*35mm Screw x 2
G  4*12mm Screw x 24	H  4*18mm Bolt x 1	I  x 1
J  x 4	K  x 2	L  x 4
M  x 6		

Tools required

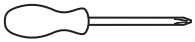

Phillips screwdriver
(medium & large)

Ruler - Use this ruler to help correctly identify the screws

mm

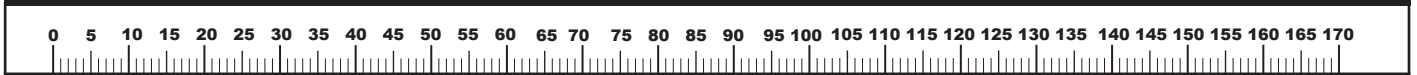

The screws length is measured from the head to the point (30mm screw shown).



inch

Using Camlocks

Step 1

Connect the male camlock as directed in the assembly instructions using a screwdriver.

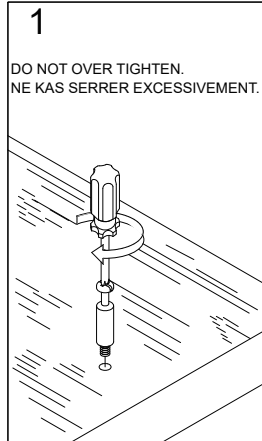

Step 2

Push the male camlock into the entry hole.

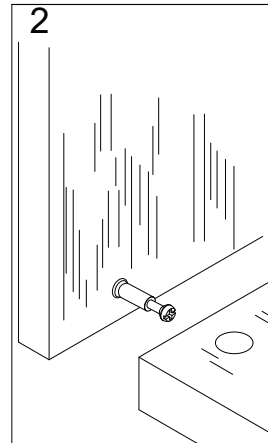

Step 3

Insert the female camlock as shown in the instructions.

Note: ensure that the arrow on the top of the camlock points towards the entry hole for the male camlock.

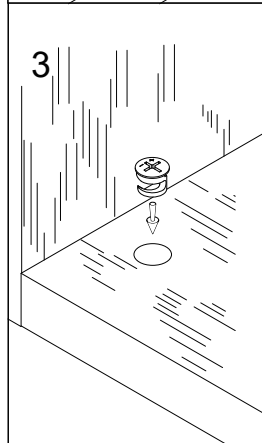

Step 4

Turn the female camlock clockwise with a screwdriver.

You should feel a click when the camlock is locked in place.

The joint is now secure.

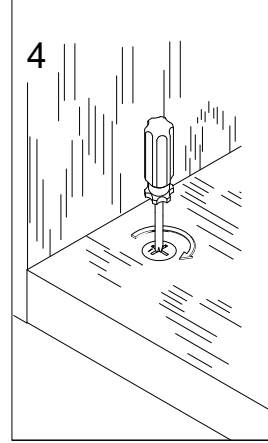

Componets - Panels

Please check you have all the panels listed below

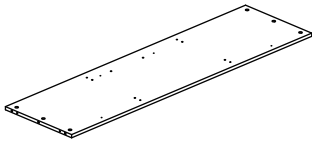

1 (1440*397*15mm x1)

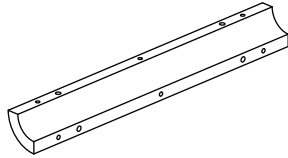

2 (397*40*40mm x2)

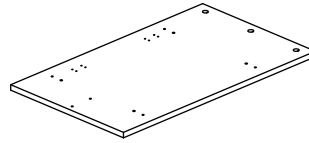

3 (676*397*15mm x1)

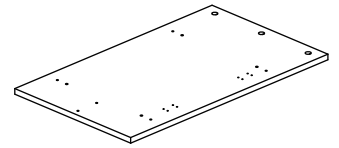

4 (676*397*15mm x1)

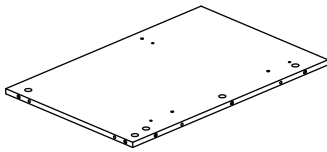

5 (586*381*12mm x1)

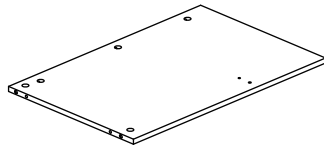

6 (586*381*12mm x1)

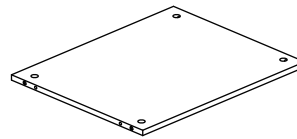

7 (469*380*12mm x2)

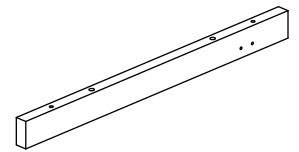

8 (416*34*15mm x1)

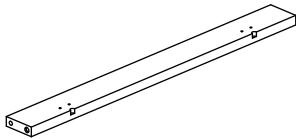

9 (528*50*15mm x1)

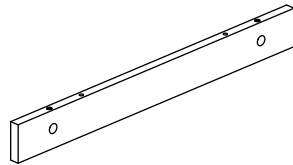

10 (552*60*15mm x1)

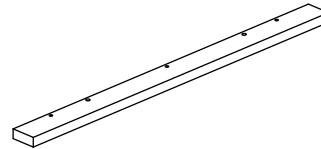

11 (586*40*15mm x1)

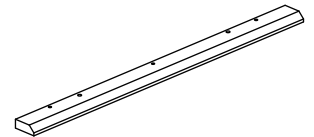

12 (586*40*15mm x1)

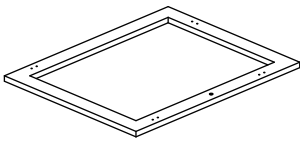

13 (580*466*15mm x1)

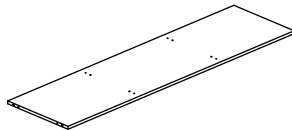

14 (1490*397*15mm x1)

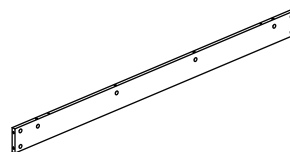

15 (1490*100*15mm x1)

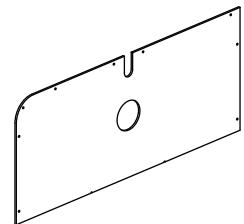

16 (490*210*3mm x2)

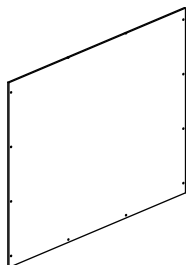

17 (490*400*3mm x2)

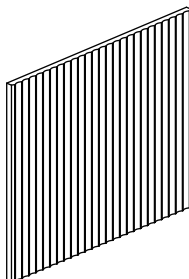

18 (463*396*15mm x2)

Assembly Instructions

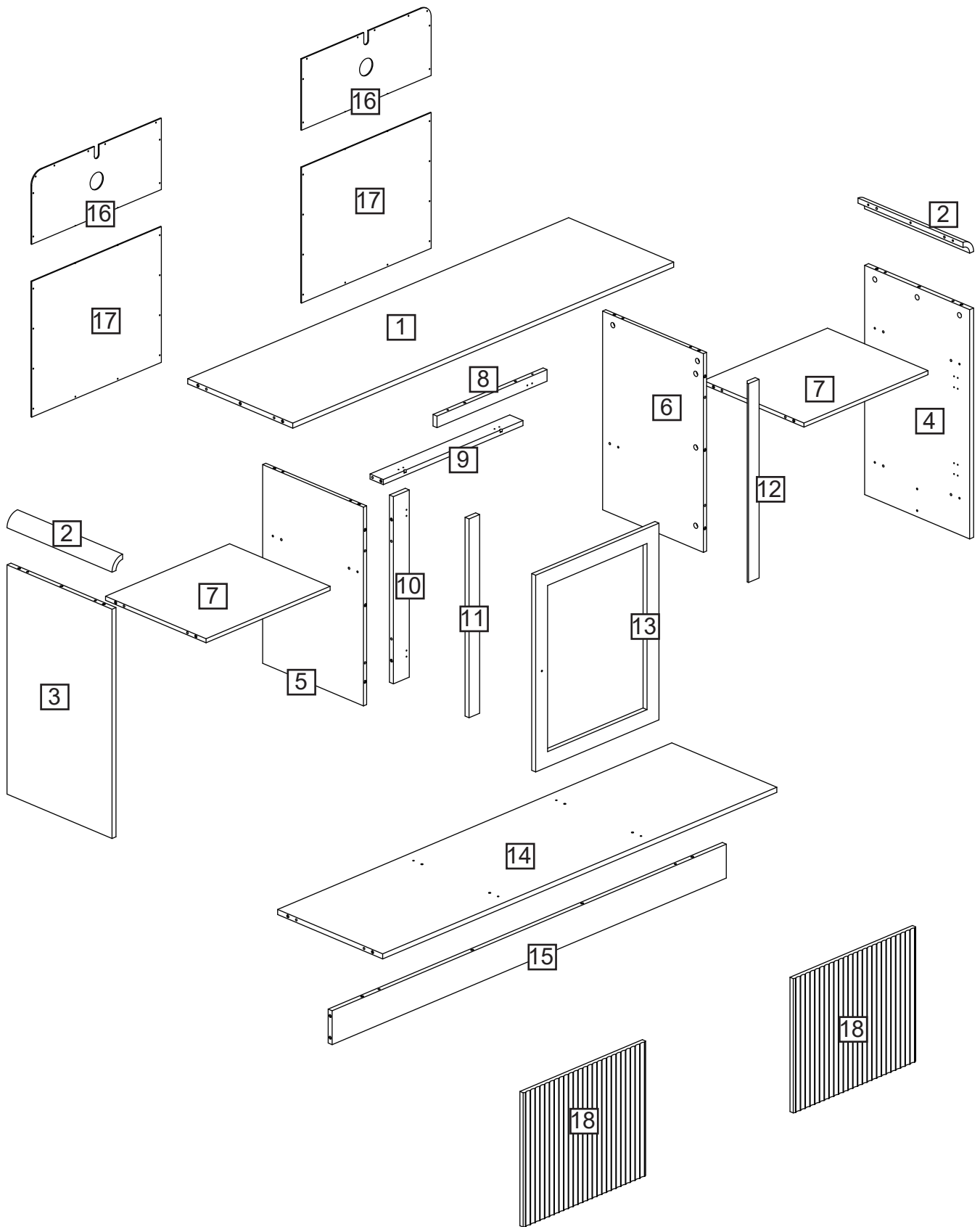

Assembly Instructions

Step 1

CAM-LOCK

Tighten until shoulder is flush with panel. Do not overtighten or undertighten (see example below)

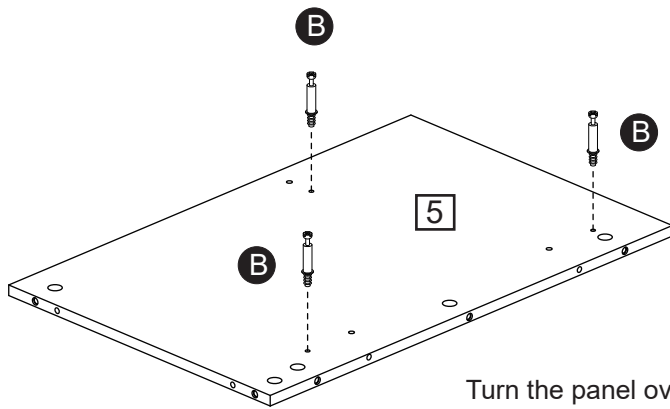
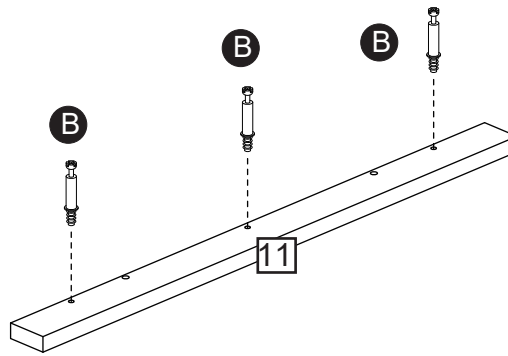
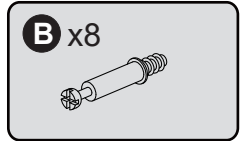
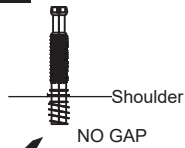
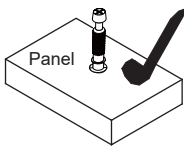
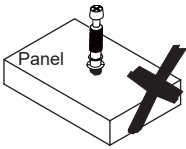

Attach cam pin (B) to panel (11). Secure cam pin (B) to panel (5). Flip over, attach cam pin (B) to panel (5).

Turn the panel over

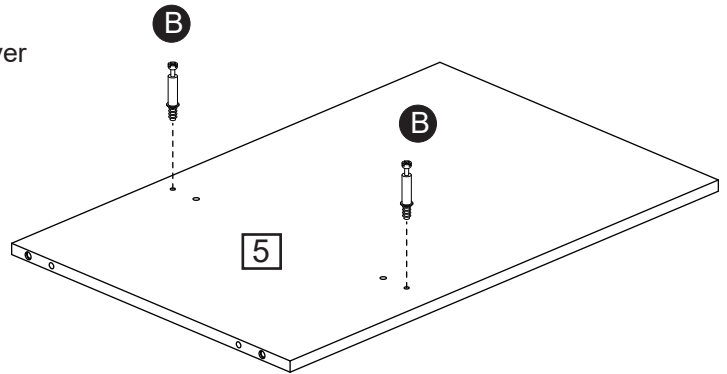

Step 2

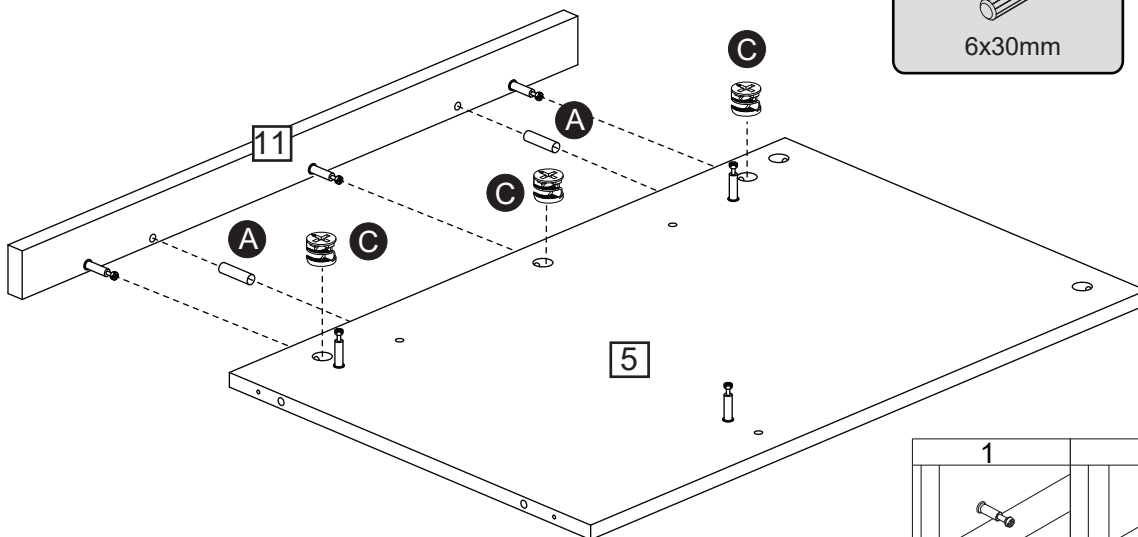
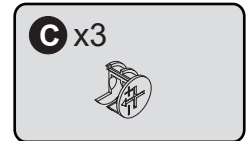

Insert wooden dowel (A), assemble panel (11) to panel (5). Place cam nut (C) and tighten.

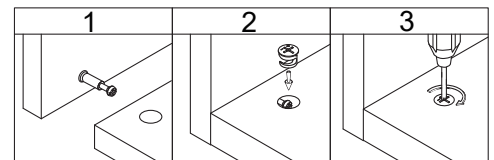

Assembly Instructions

Step 3

CAM-LOCK

Tighten until shoulder is flush with panel. Do not overtighten or undertighten (see example below)

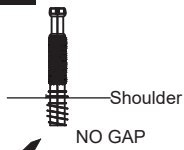
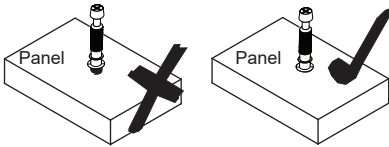

B x6

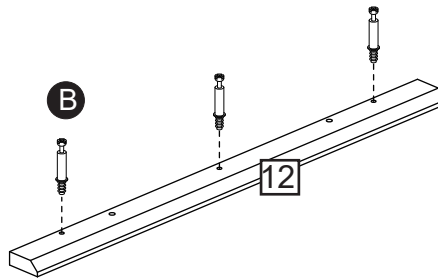
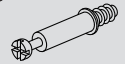

Attach cam pin (B) to panel (12). Secure cam pin (B) to panel (6). Flip over, attach cam pin (B) to panel (6).

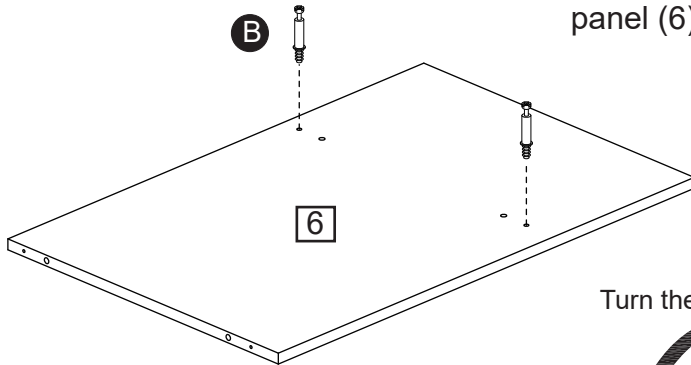

Turn the panel over



180°

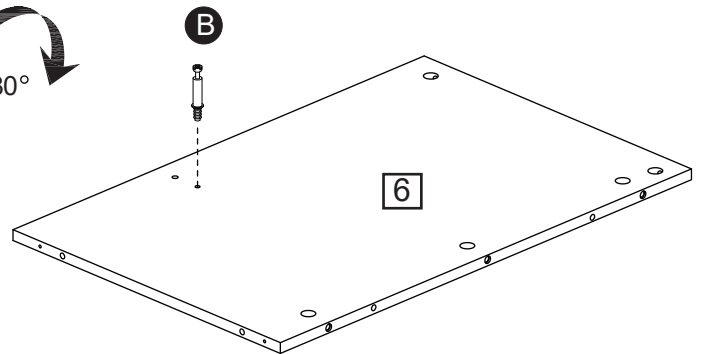

Step 4

A x2

6x30mm



C x3

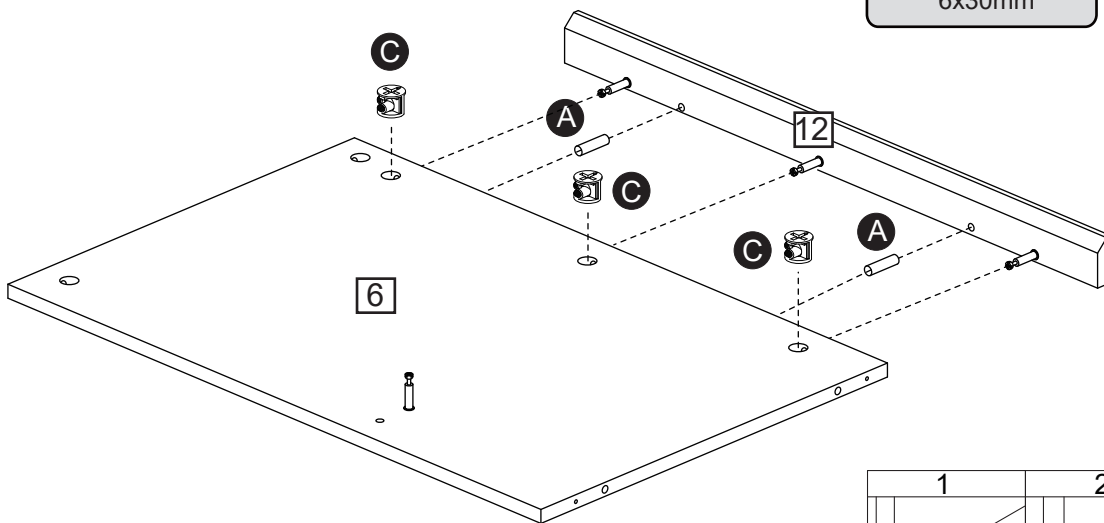

Insert wooden dowel (A), assemble panel (12) to panel (6). Place cam nut (C) and tighten.

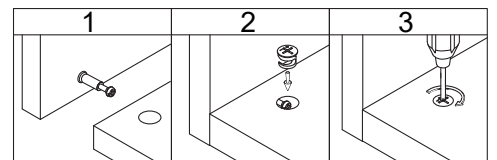

Assembly Instructions

Step 5

Insert wooden dowel (A), assemble panel (6) to panel (9). Place cam nut (C) and tighten.
Assemble panel (5) to panel (9). Place cam nut (C) and tighten.

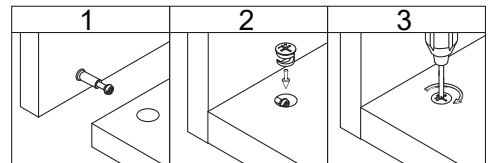
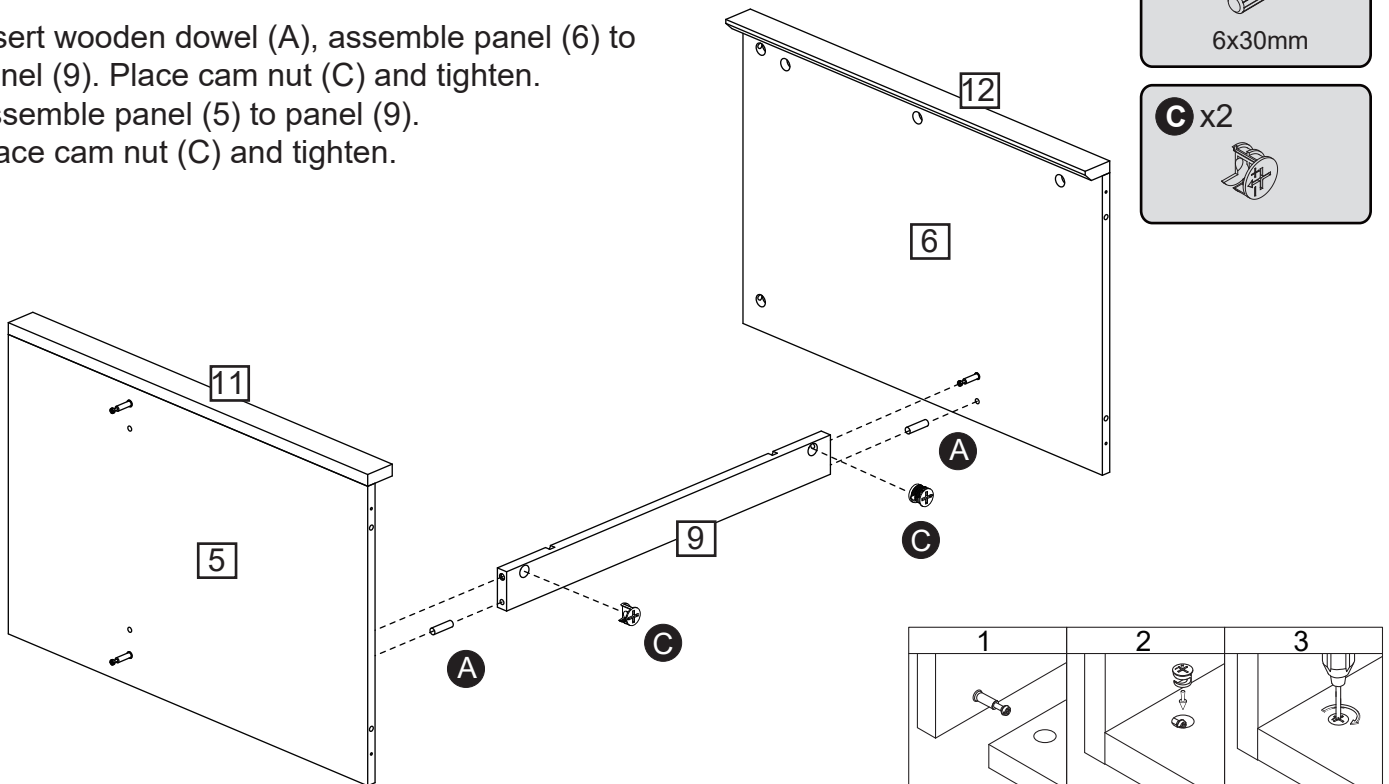
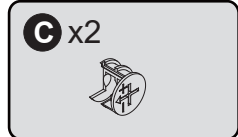

Step 6

Insert wooden dowel (A), assemble panel (7) to panel (6). Place cam nut (C) and tighten.
Assemble panel (7) to panel (5). Place cam nut (C) and tighten.

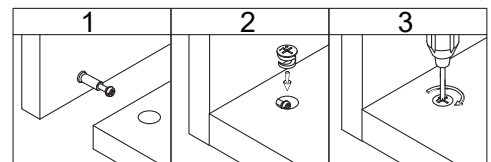
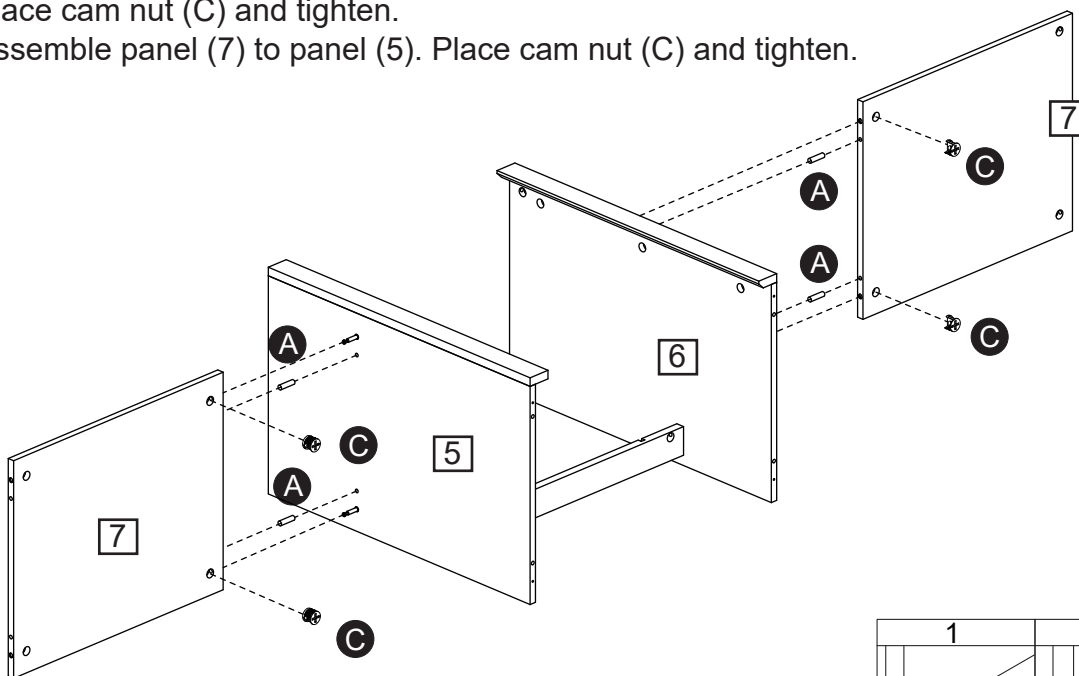
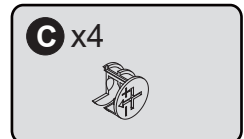

Assembly Instructions

Step 7

CAM-LOCK
Tighten until shoulder is flush with panel. Do not overtighten or undertighten (see example below)

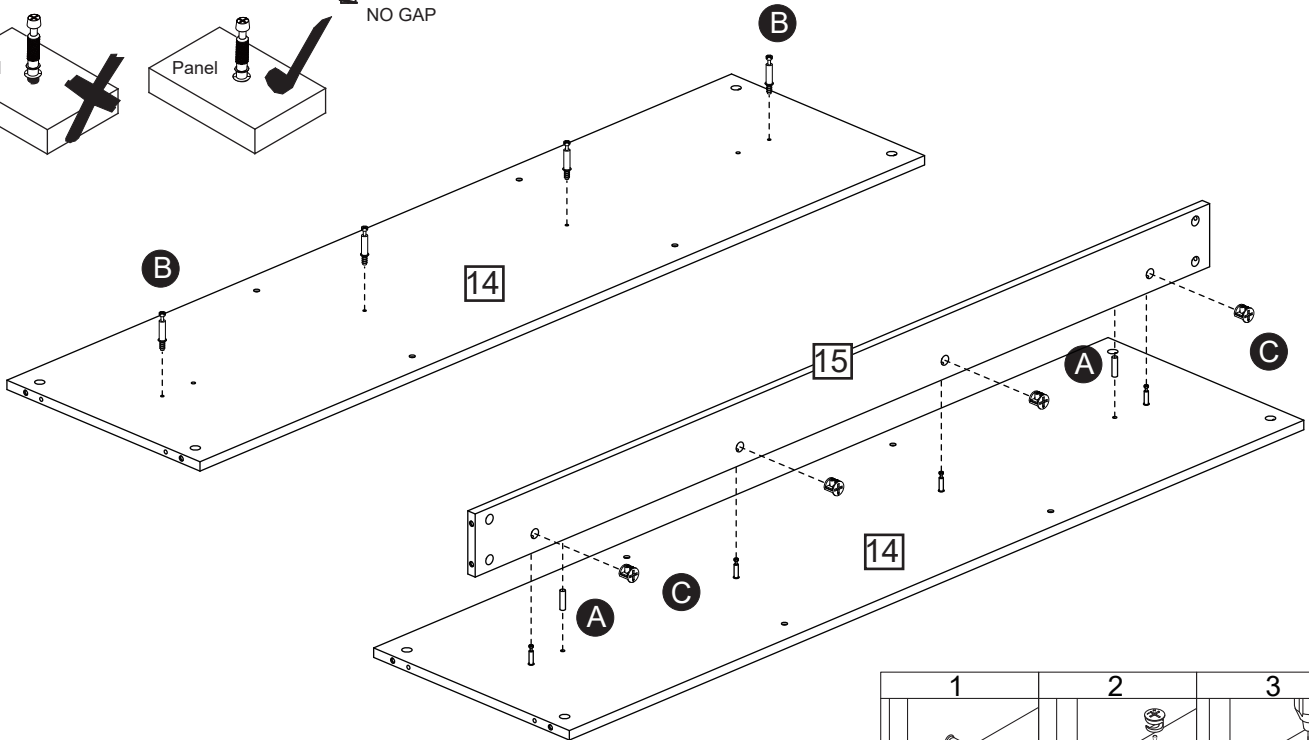
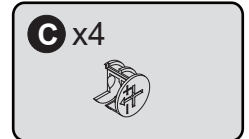
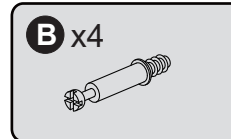
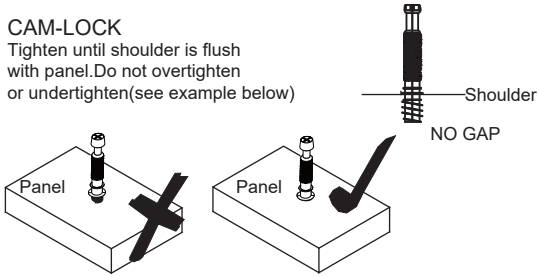

Secure cam pin (B) to panel (14). Assemble panel (15) to panel (14), place cam nut (C), and tighten.

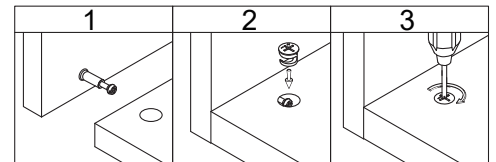

Step 8

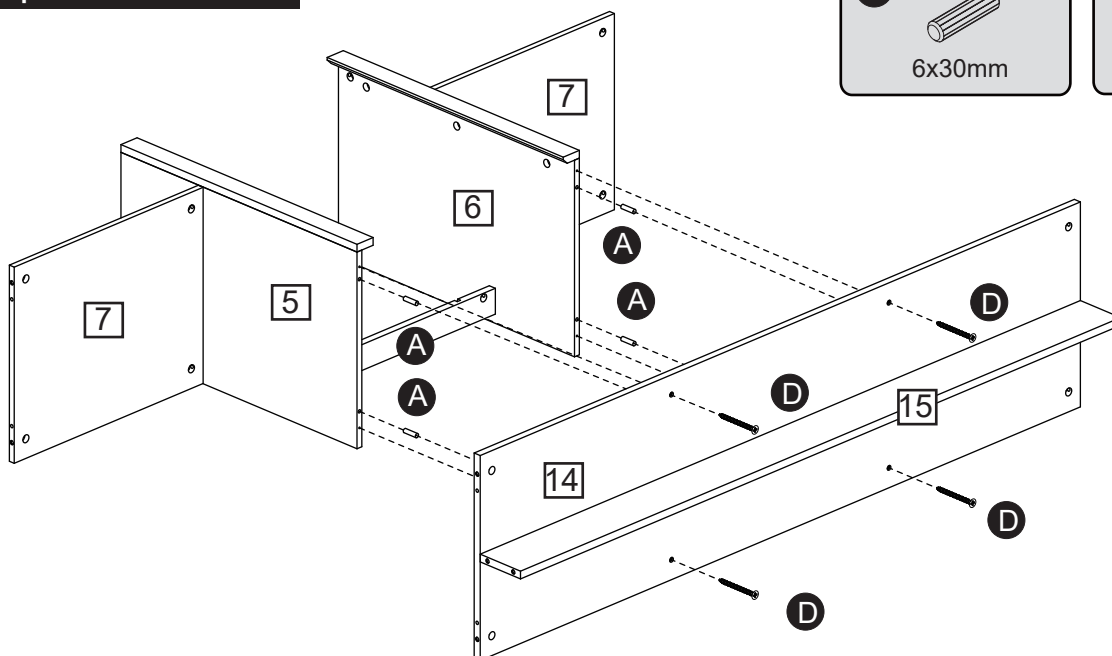
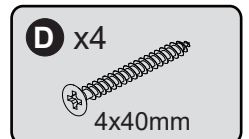
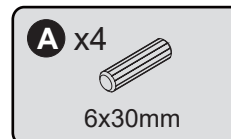

Insert wooden dowel (A), use screw (D) to assemble panel (14) to panel (5) and panel (6).

Assembly Instructions

Step 9

CAM-LOCK

Tighten until shoulder is flush with panel. Do not overtighten or undertighten (see example below)

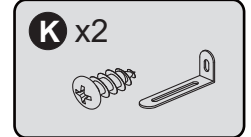
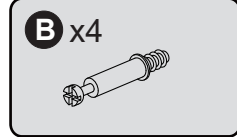
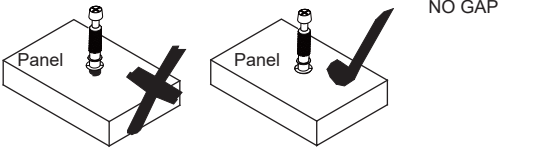

Do not fully tighten wall fixing brackets until it's ready to be fixed to the wall.

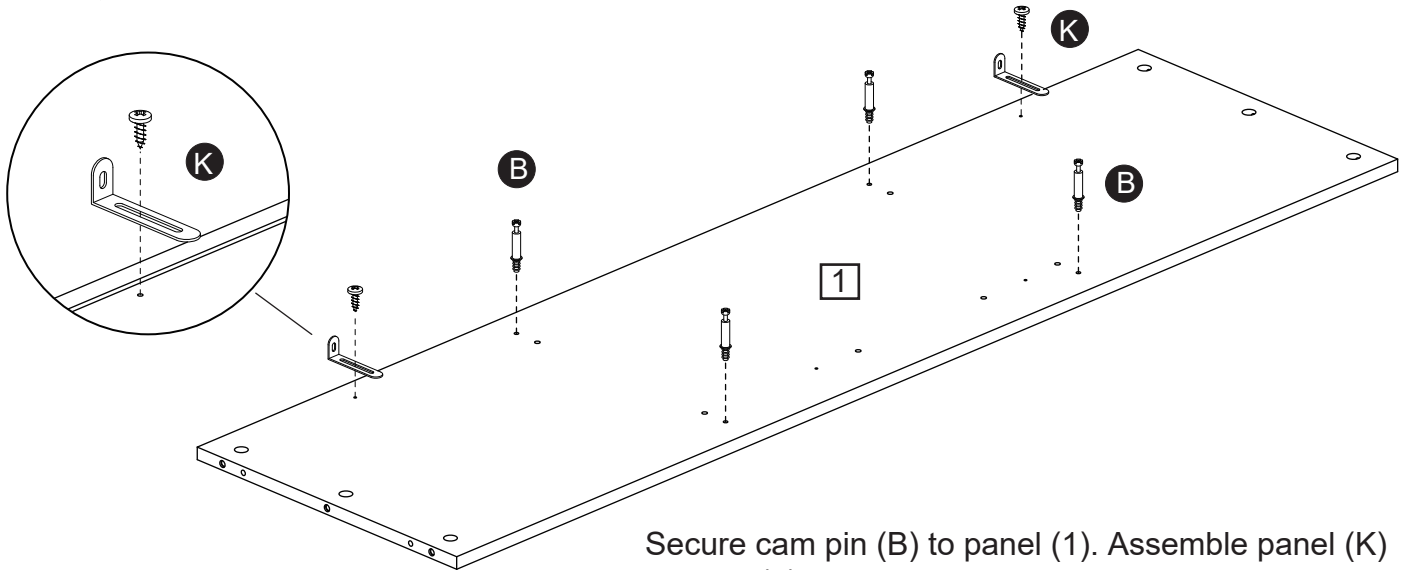

Secure cam pin (B) to panel (1). Assemble panel (K) to panel (1) and tighten.

Step 10

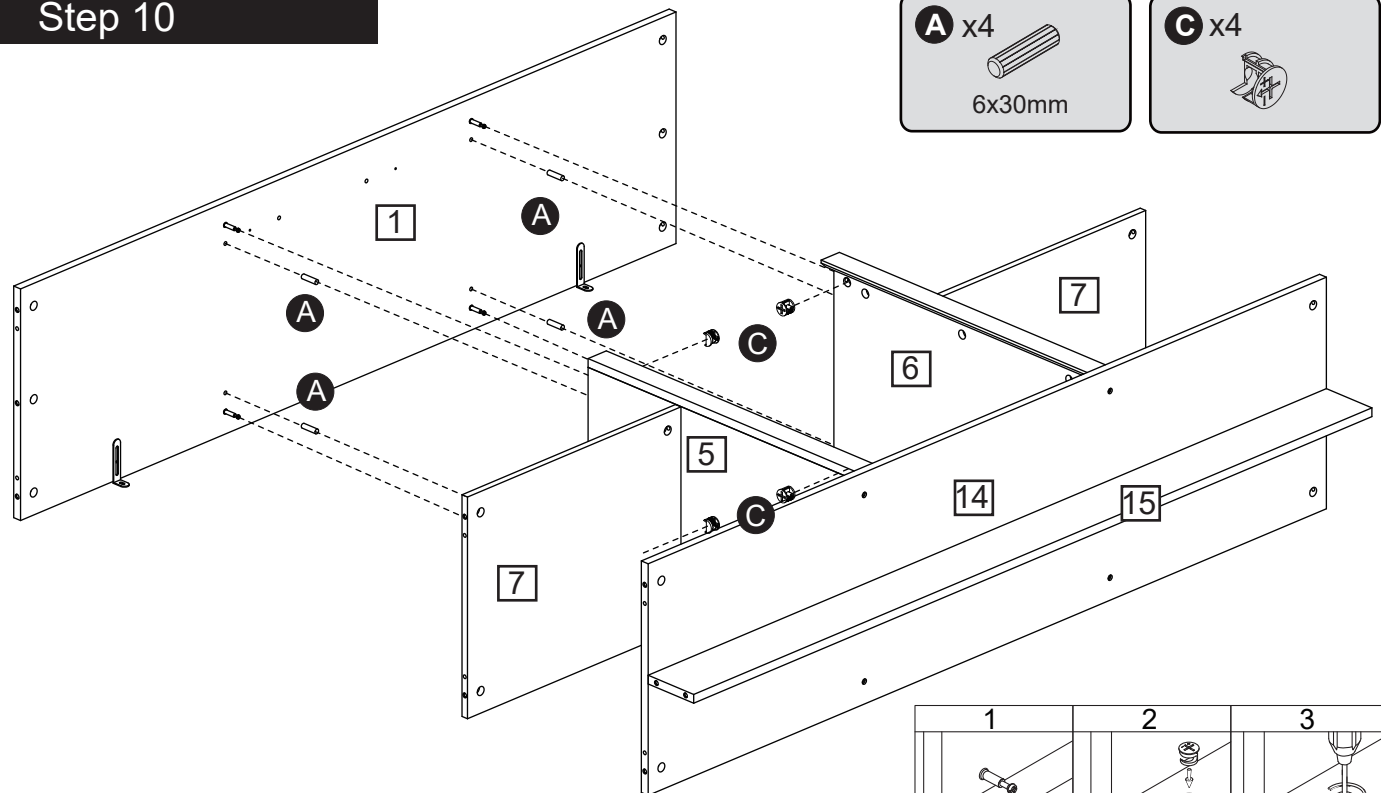

Insert wooden dowel (A), assemble panel (1) to panel (6) and panel (5), place cam nut (C), and tighten.

Assembly Instructions

Step 11

CAM-LOCK

Tighten until shoulder is flush with panel. Do not overtighten or undertighten (see example below)

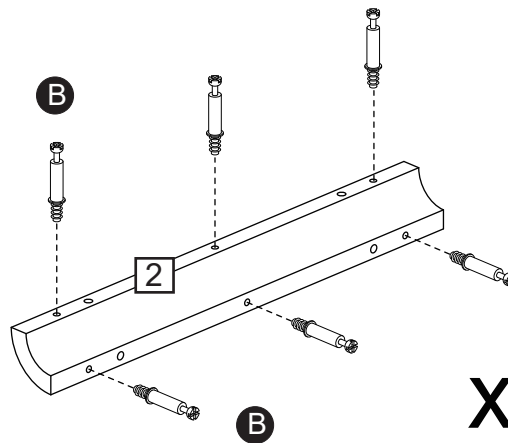
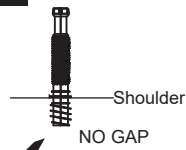
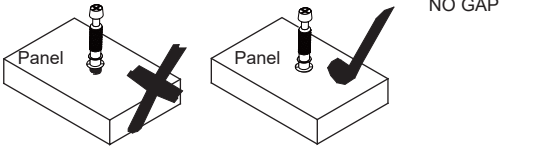

B x12

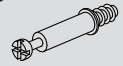

Assemble cam pin (B) to panel (2).

Step 12

CAM-LOCK

Tighten until shoulder is flush with panel. Do not overtighten or undertighten (see example below)

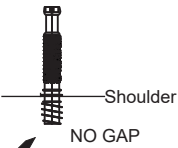
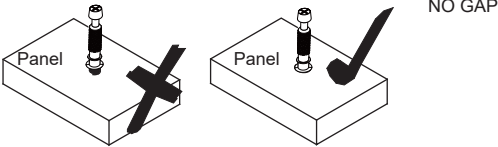

A x2
6x30mm



B x6

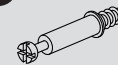

C x3

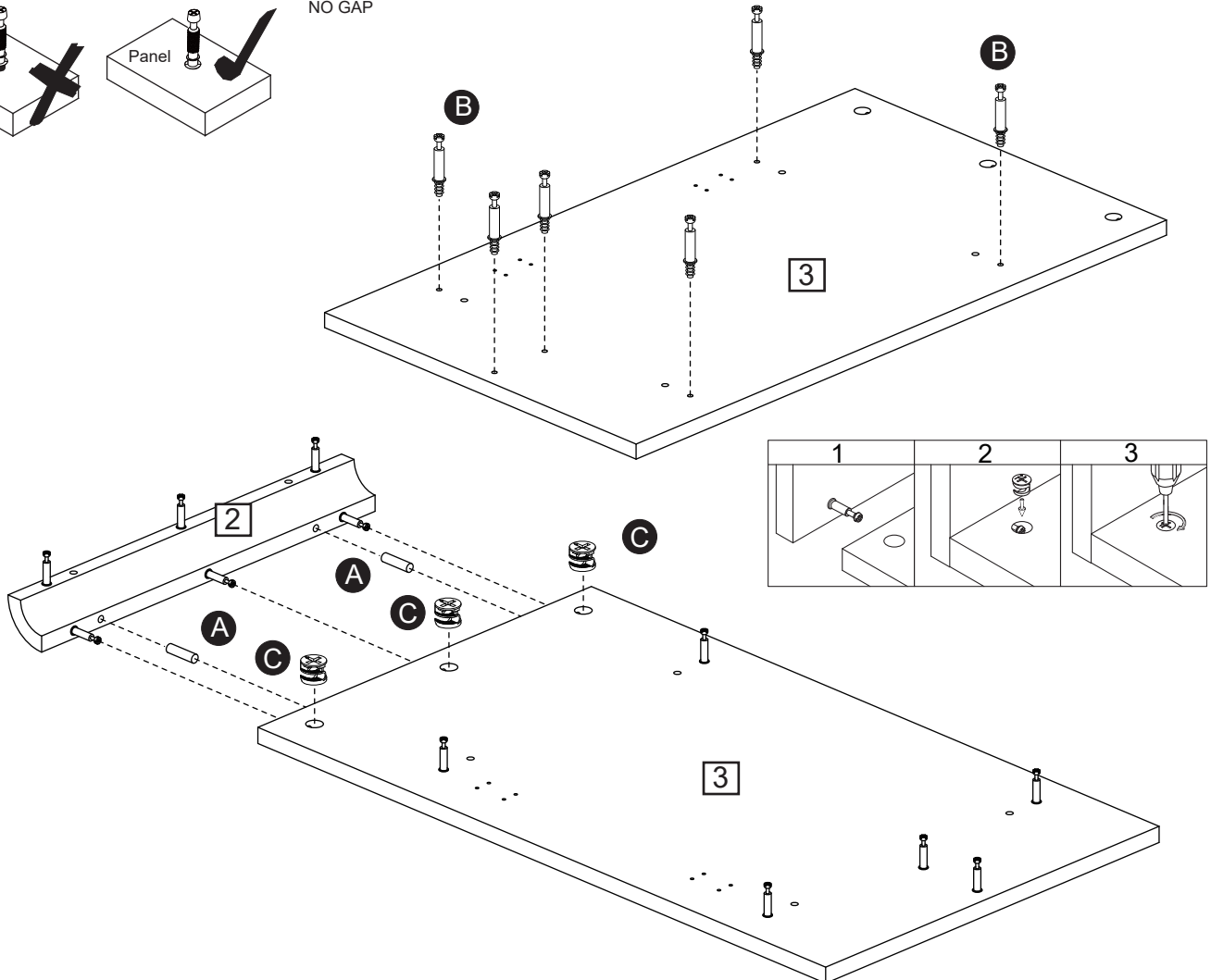

Assemble panel (B) to panel (3). Assemble panel (2) to panel (3), place cam nut (C), and tighten.

Assembly Instructions

Step 13

CAM-LOCK
Tighten until shoulder is flush with panel. Do not overtighten or undertighten (see example below)

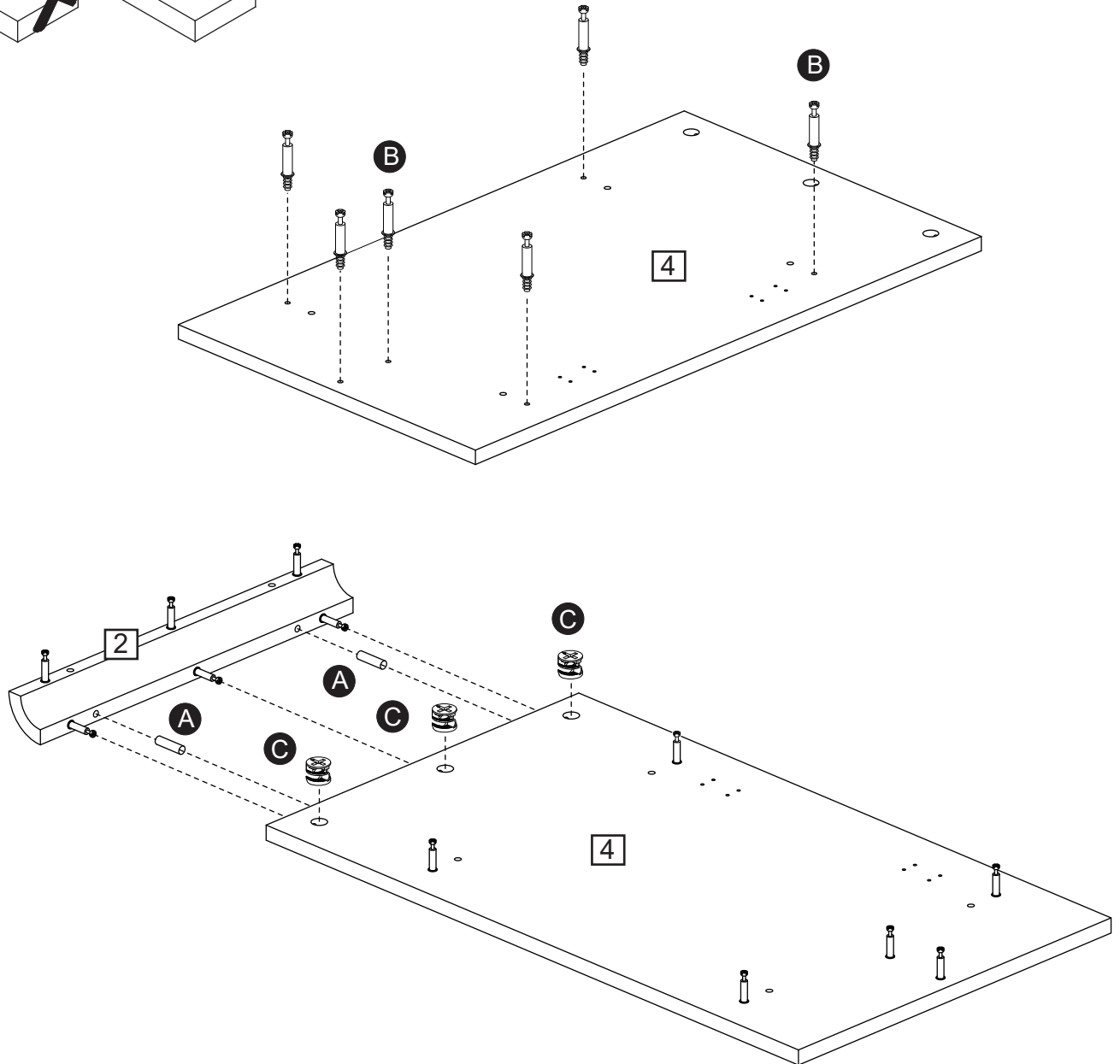
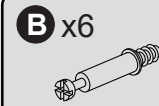
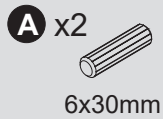
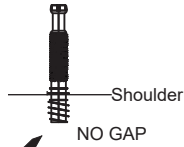
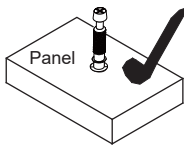
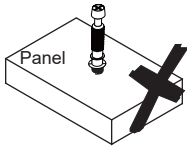

Assemble cam pin (B) to panel (4). Assemble panel (2) to panel (4), place cam nut (C), and tighten.

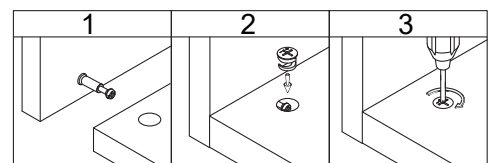

Assembly Instructions

Step 14

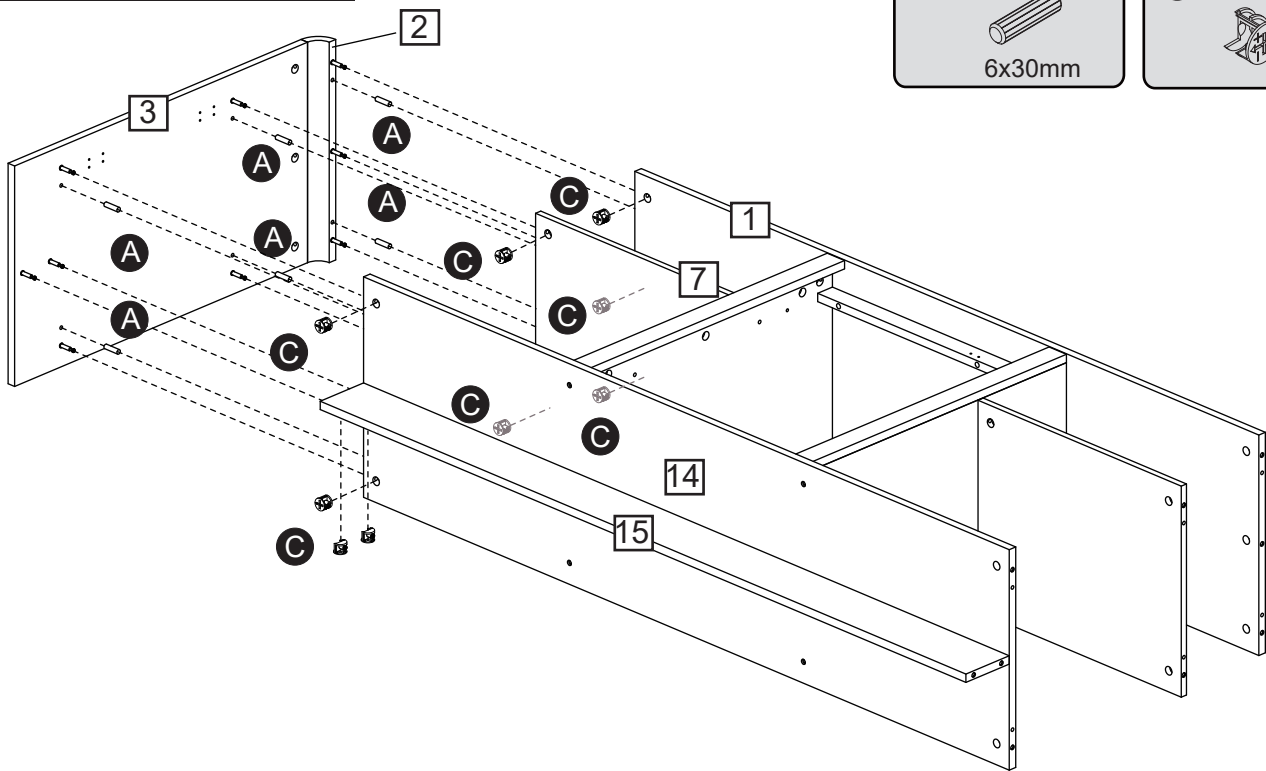
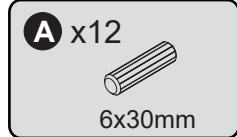

Insert wooden dowel (A), assemble panel (3) and panel (2) to panel (15), panel (14), panel (7), and panel (1). Tighten with cam nut (C).

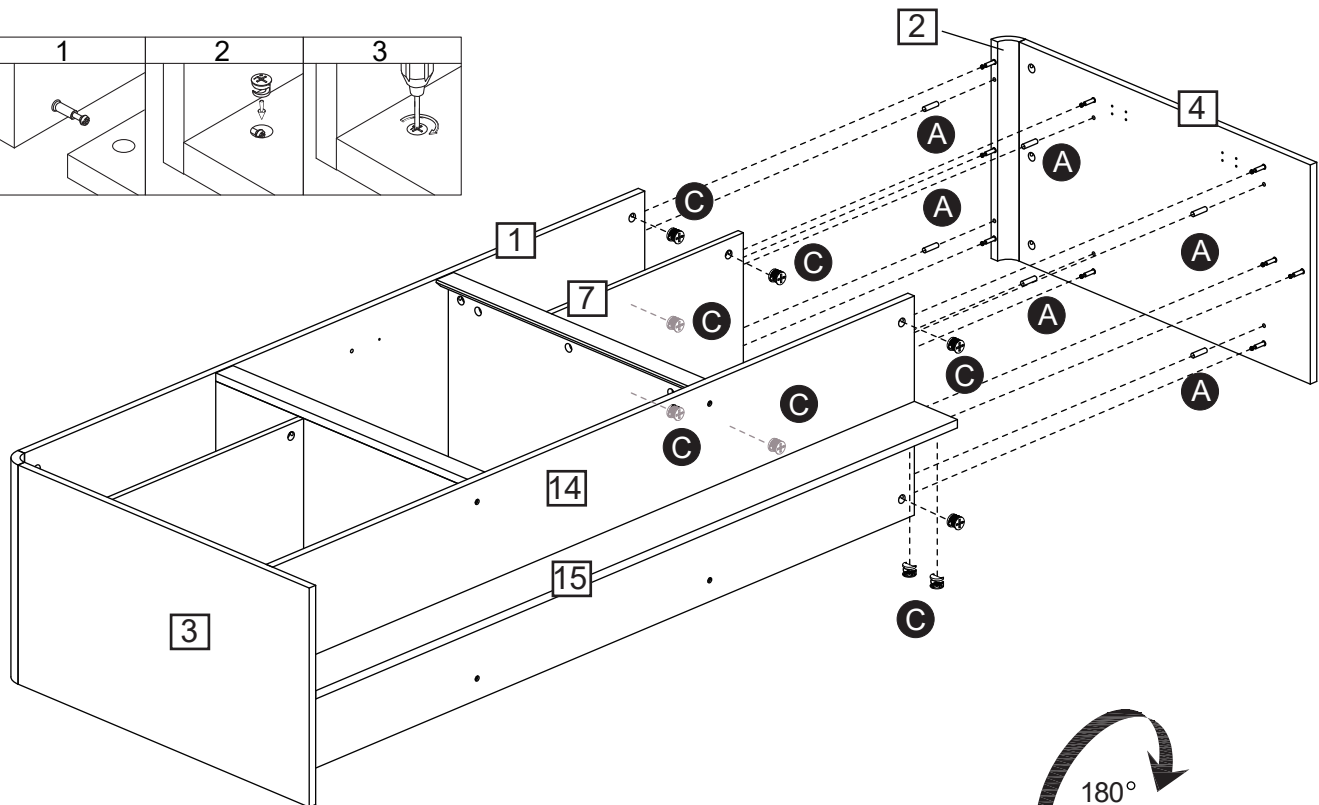
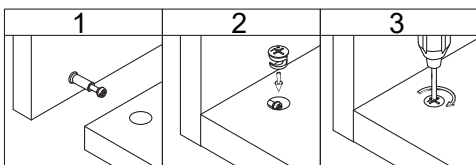

After completing Step 14 , it is recommended that two people turn the product 180° to the next step.

Assembly Instructions

Step 15

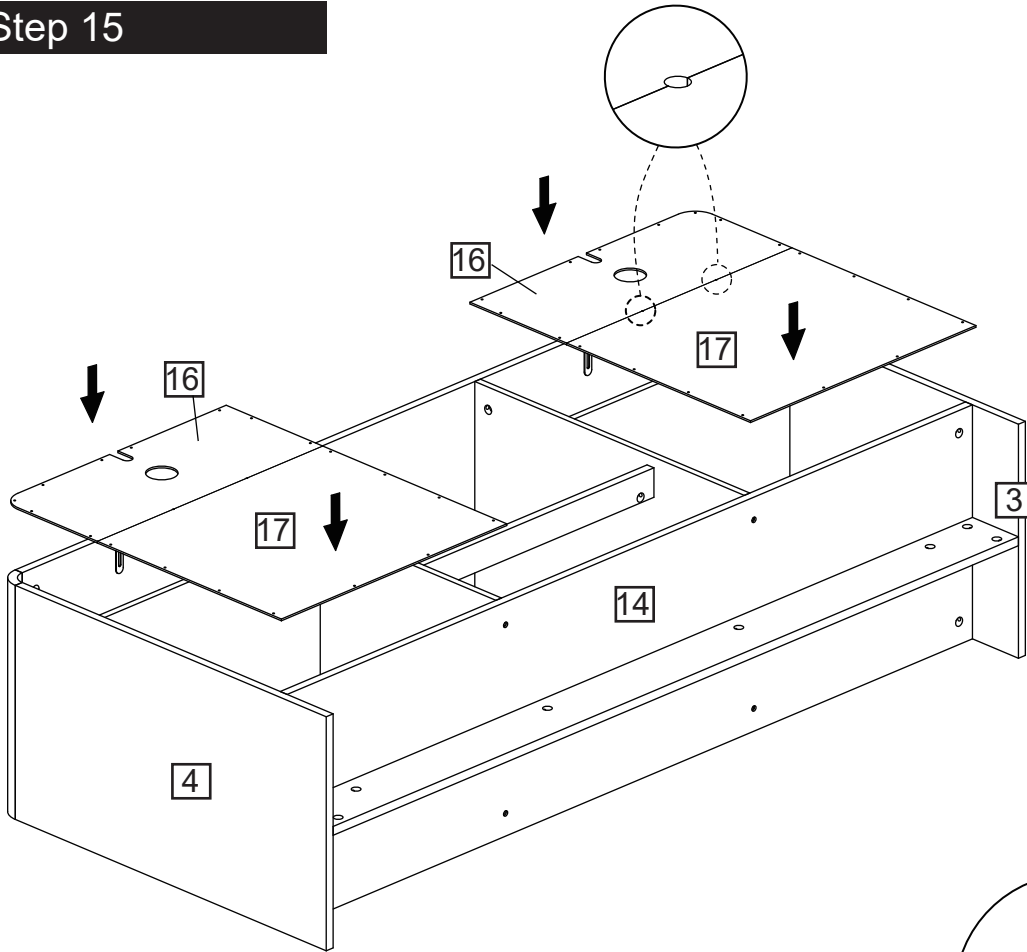

E x42
2.5x12mm

L x4

As shown, assemble panel (16) and (17) to panel (3) and (4) using screw (E) and (L), and tighten.

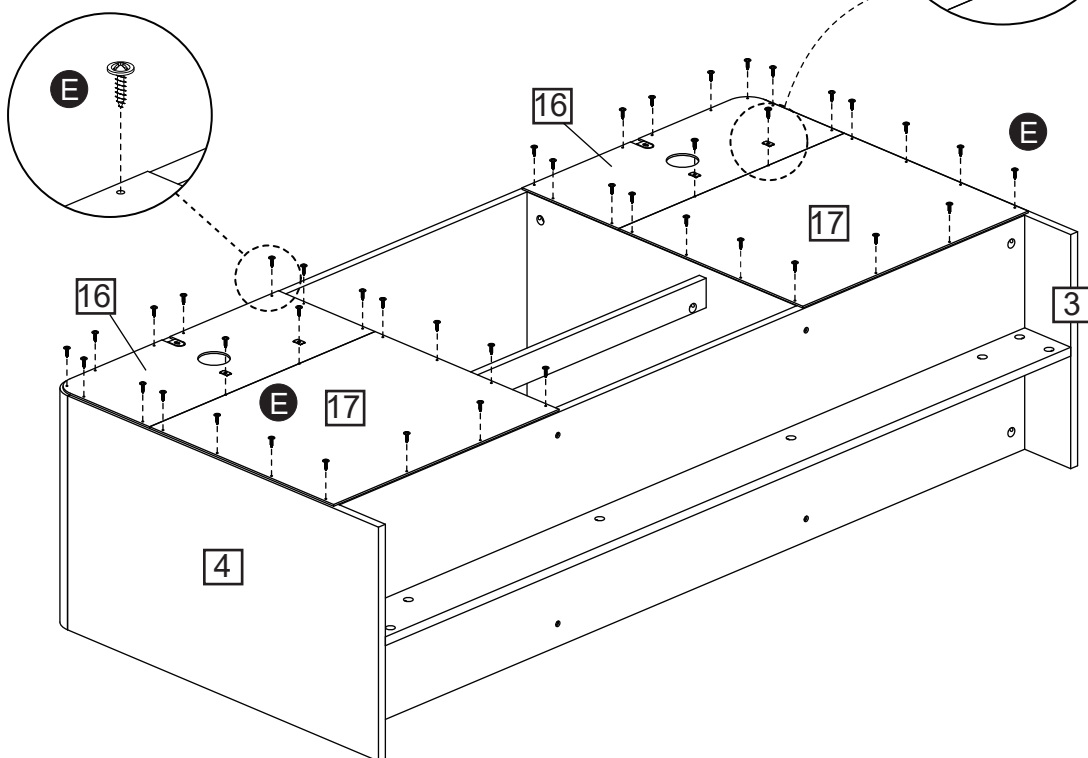

Assembly Instructions

Step 16

A x4
6x30mm

C x2

F x2
4x35mm

As shown, insert wooden dowel (A) to assemble panel (8) and panel (1), and secure with (F).

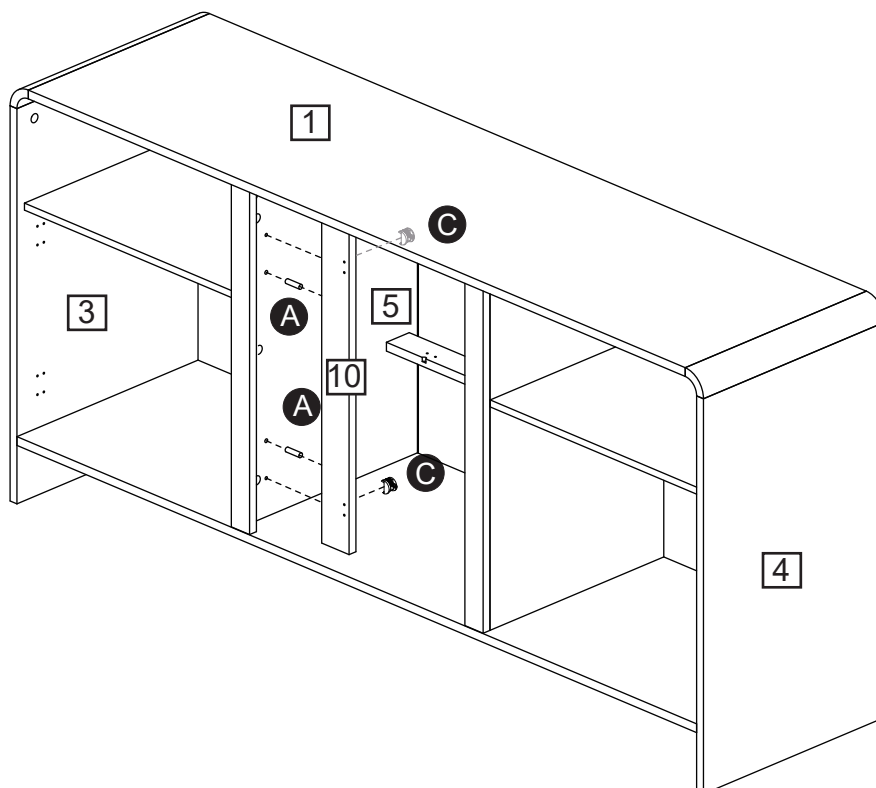
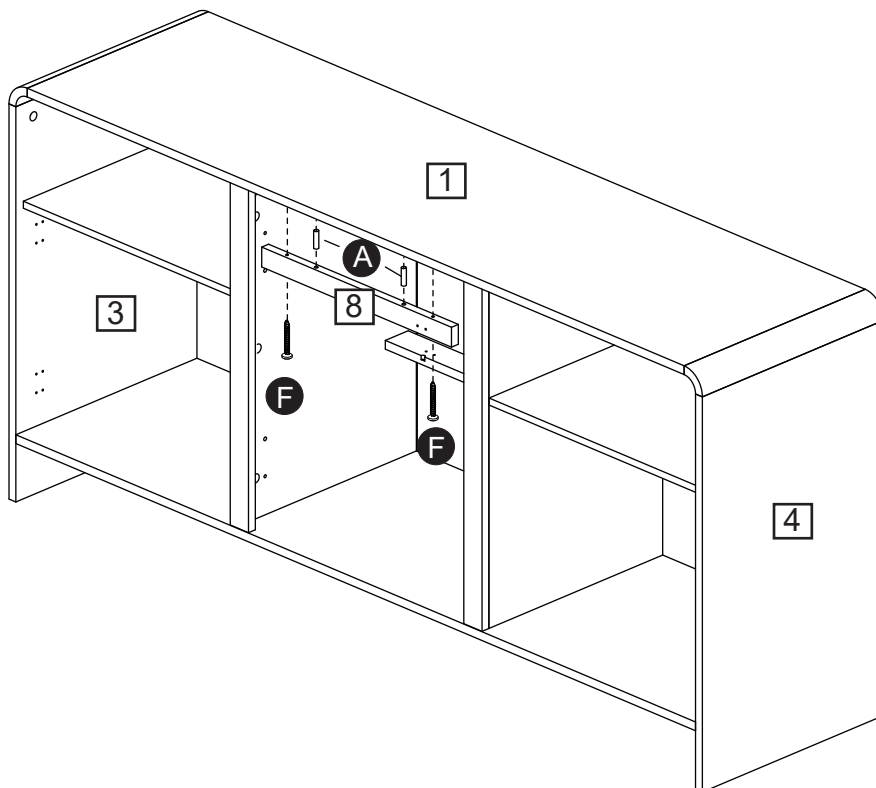

As shown, insert wooden dowel (A) to assemble panel (10) and panel (5), place cam nut (C), and tighten.

Assembly Instructions

Step 17

G x24



4x12mm

J x4

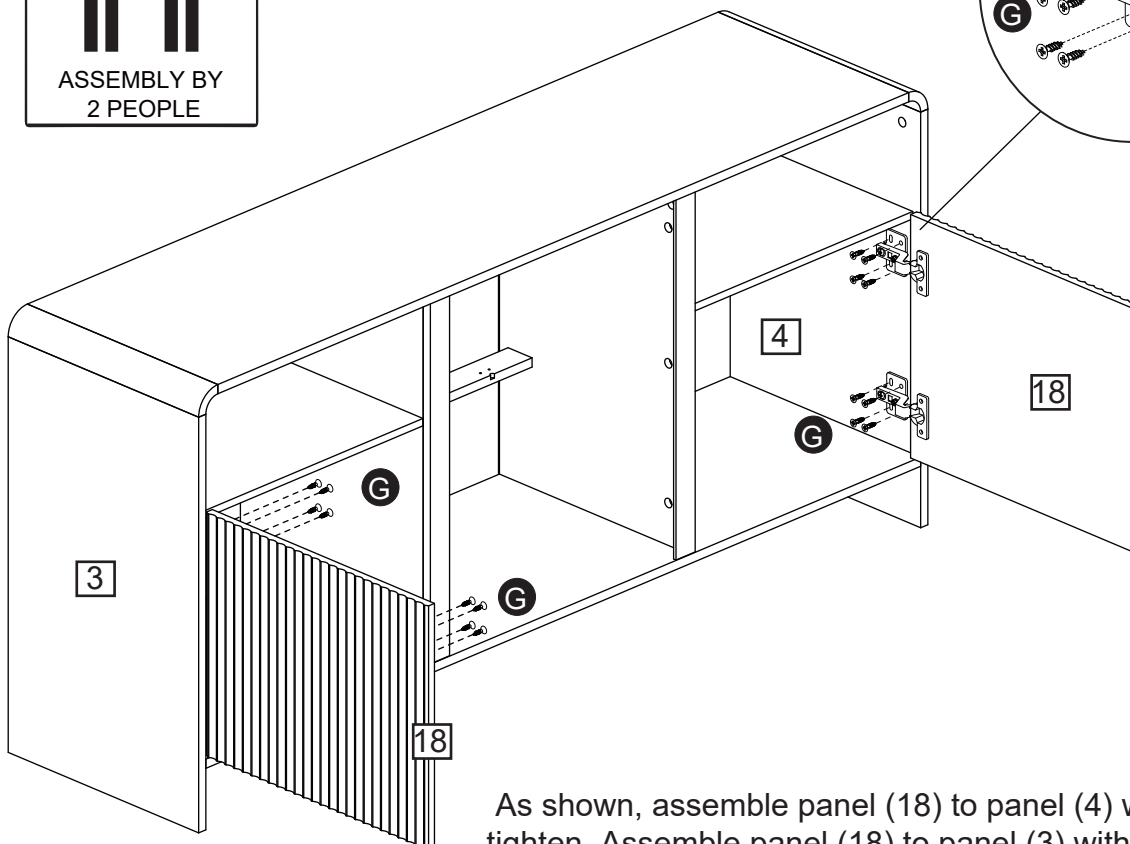
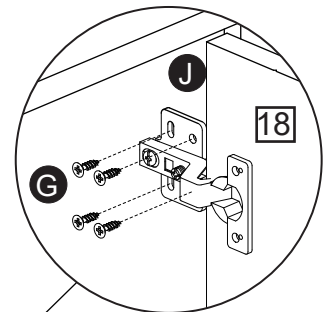
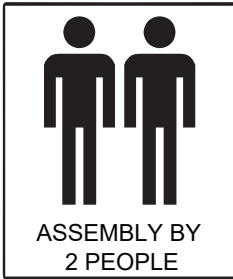
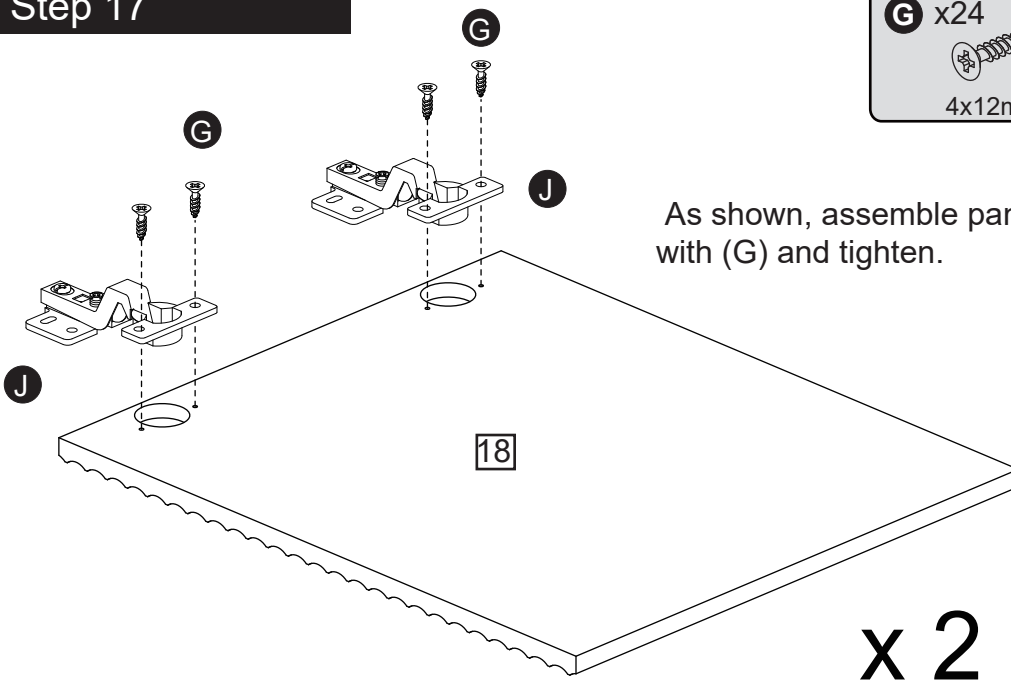

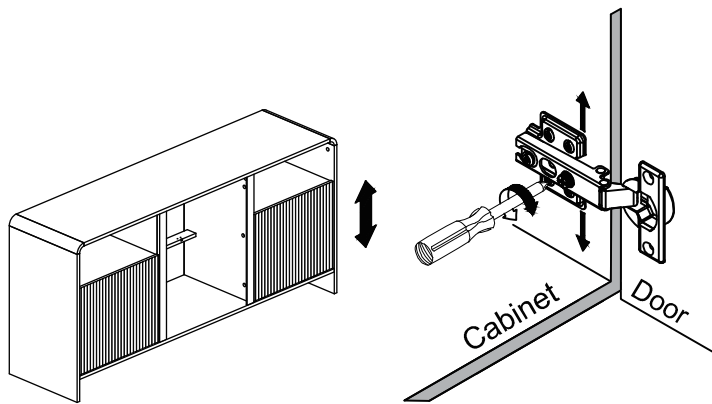
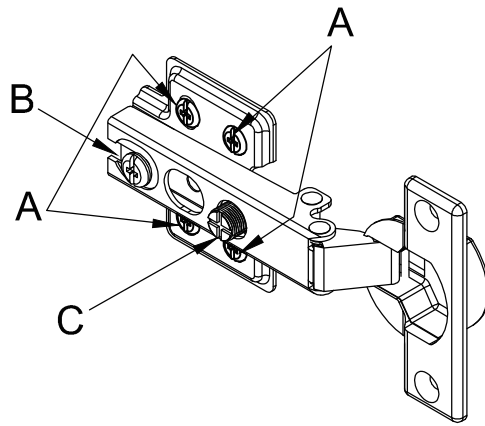

To adjust the vertical height.

Loosen the four screws "A" on both hinges. Two of them are usually in slotted holes which allows you to adjust up or down by a few mm. Then tighten back up.

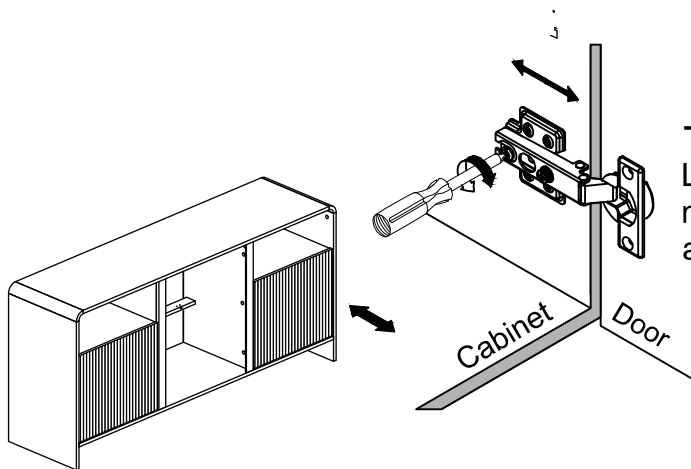

To adjust depth.

Loosen screw "B" and adjust door, if the door can not be adjusted, please loosen screw "C", then try again. Tighten screw "B" and "C".

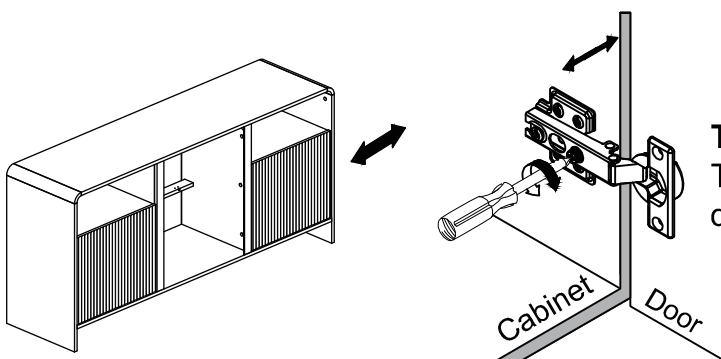

To adjust side ways.

Turning the screw "C" on BOTH hinges on each door.

Assembly Instructions

Step 18

Assemble handle (I) and bolt (H) to panel (13).

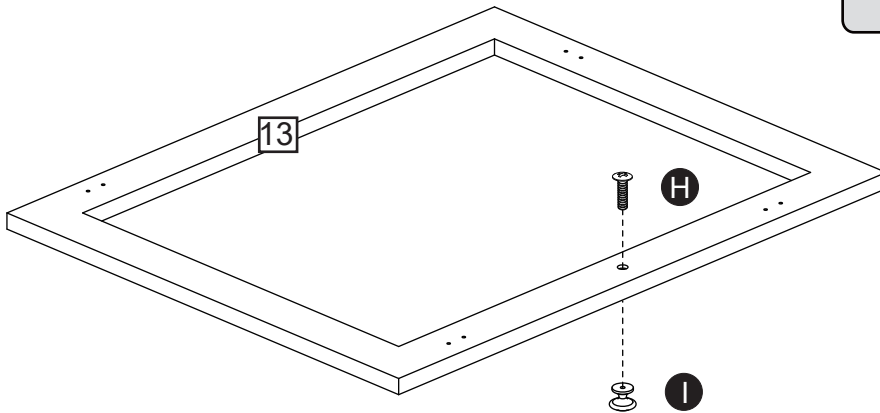
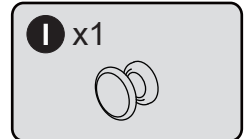
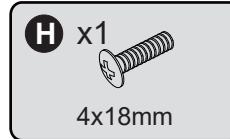

Step 19

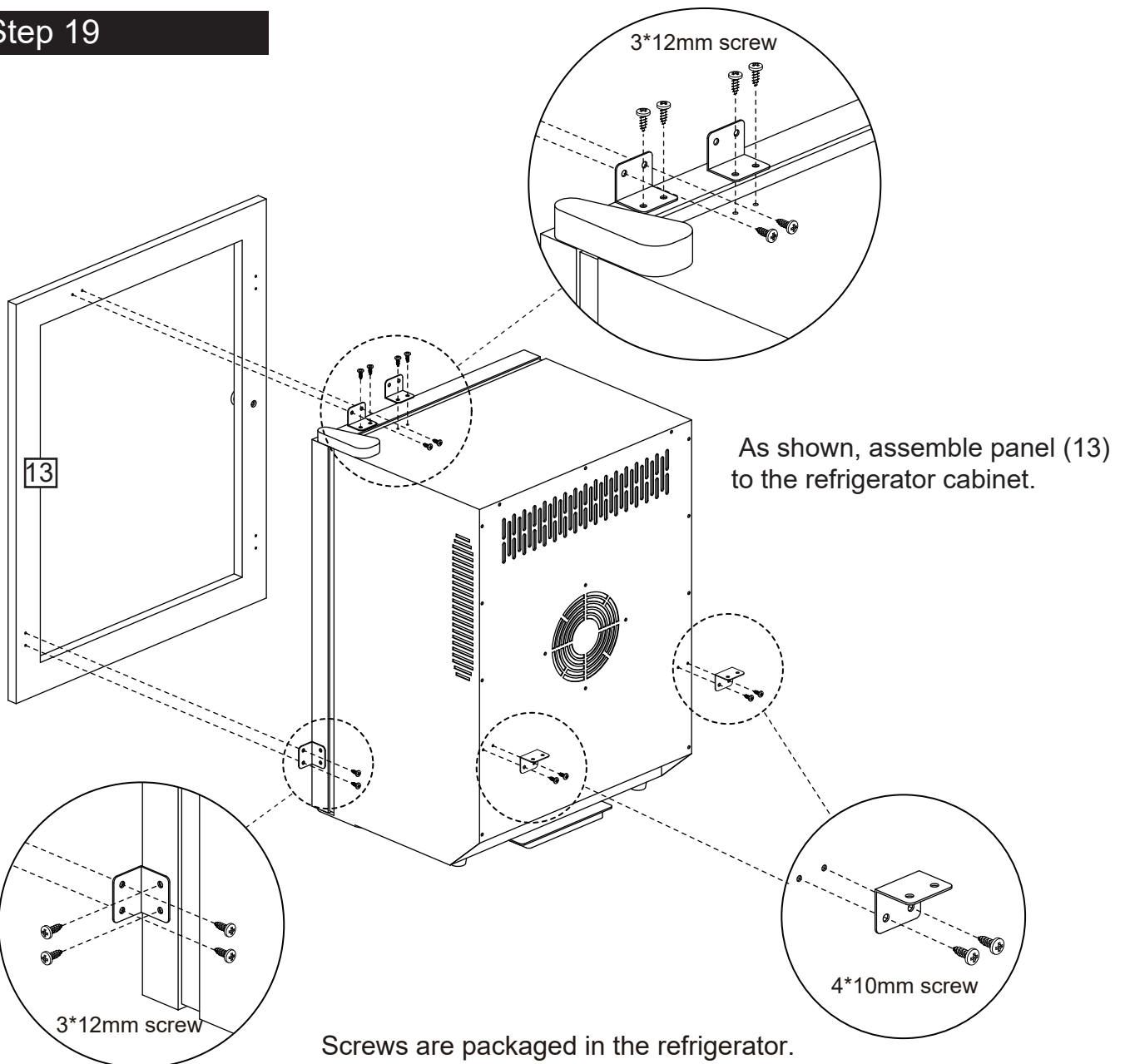

Assembly Instructions

Step 20

As shown, assemble panel (13) to the refrigerator cabinet.

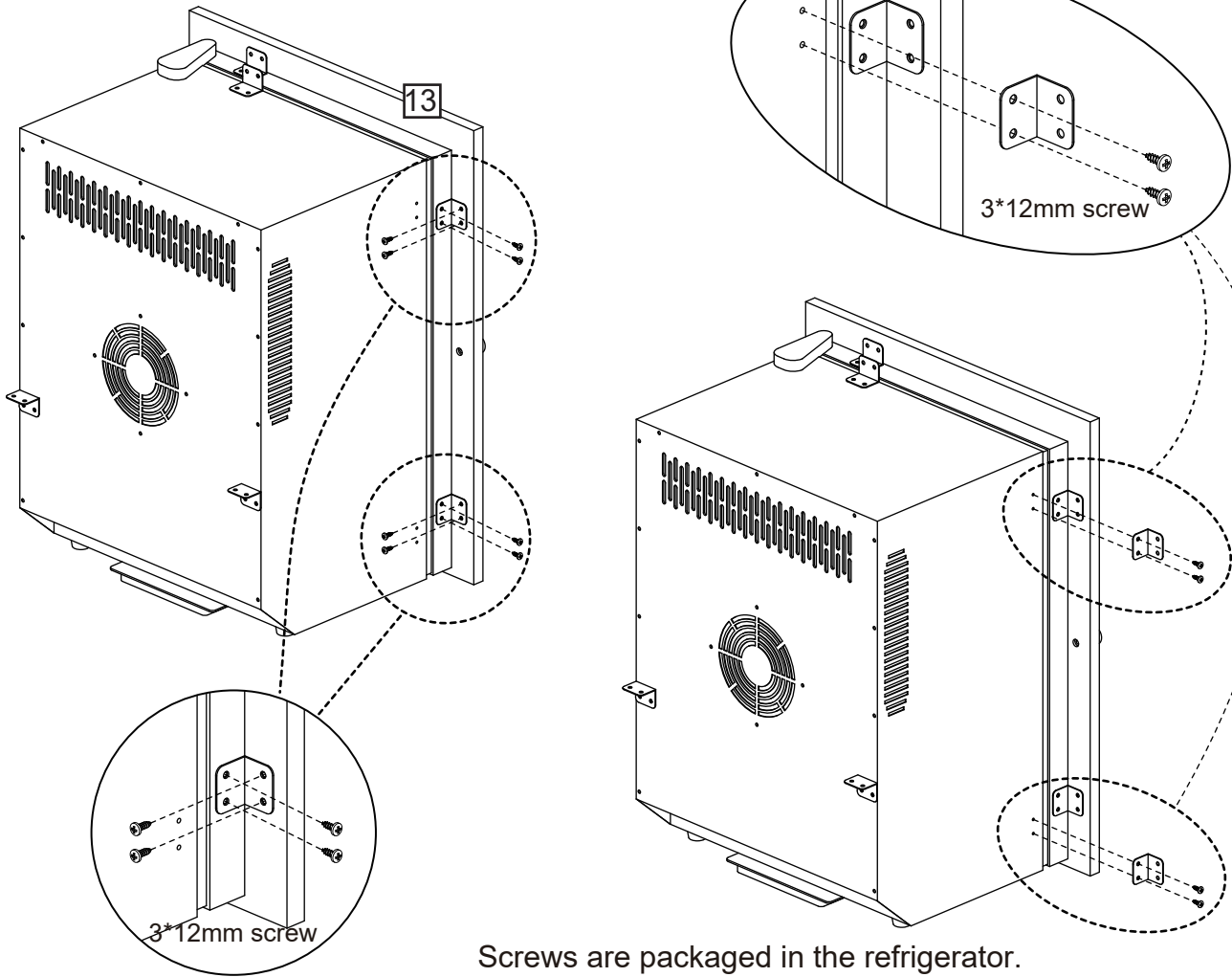

Step 21

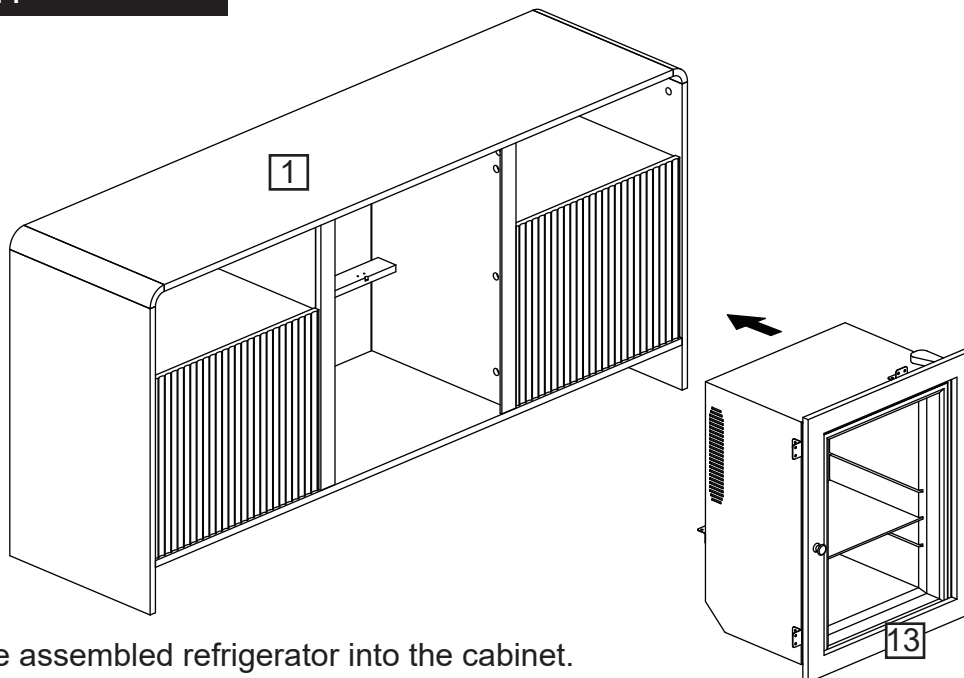

Place the assembled refrigerator into the cabinet.

Assembly Instructions

Step 22

Screws are packaged in the refrigerator.

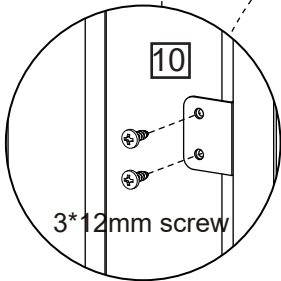
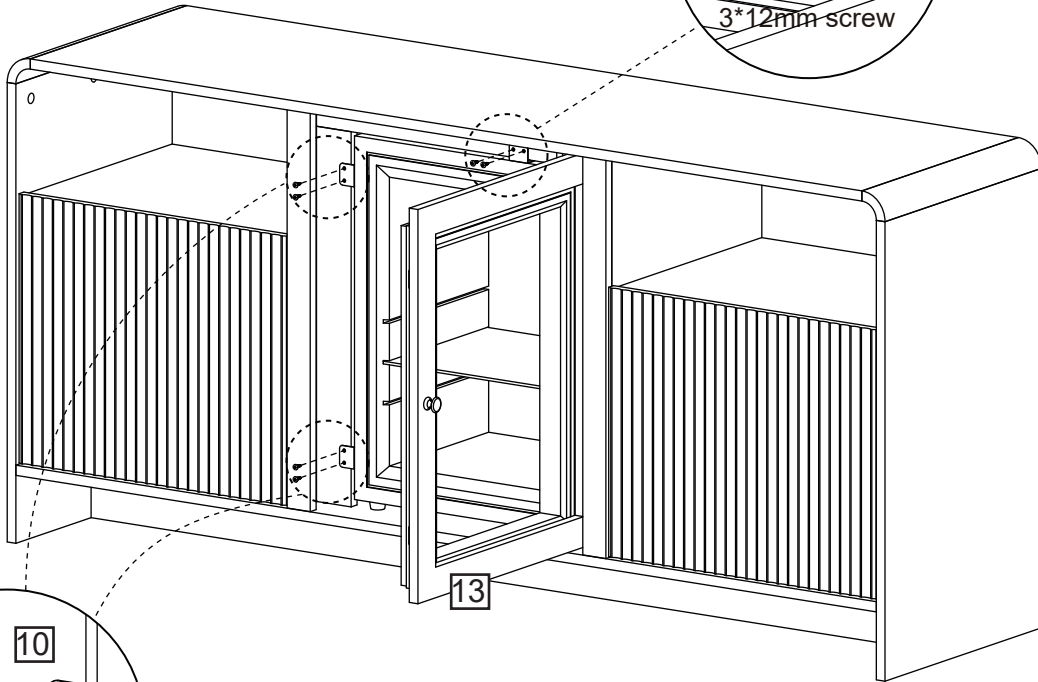
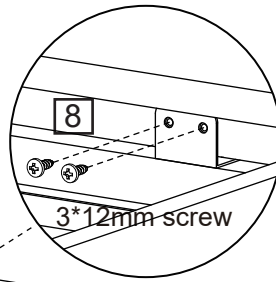

As shown, secure the refrigerator with screws to panel (8), (10), and (9).

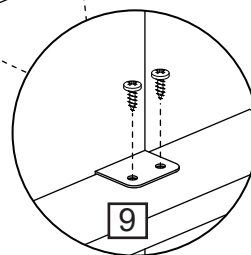
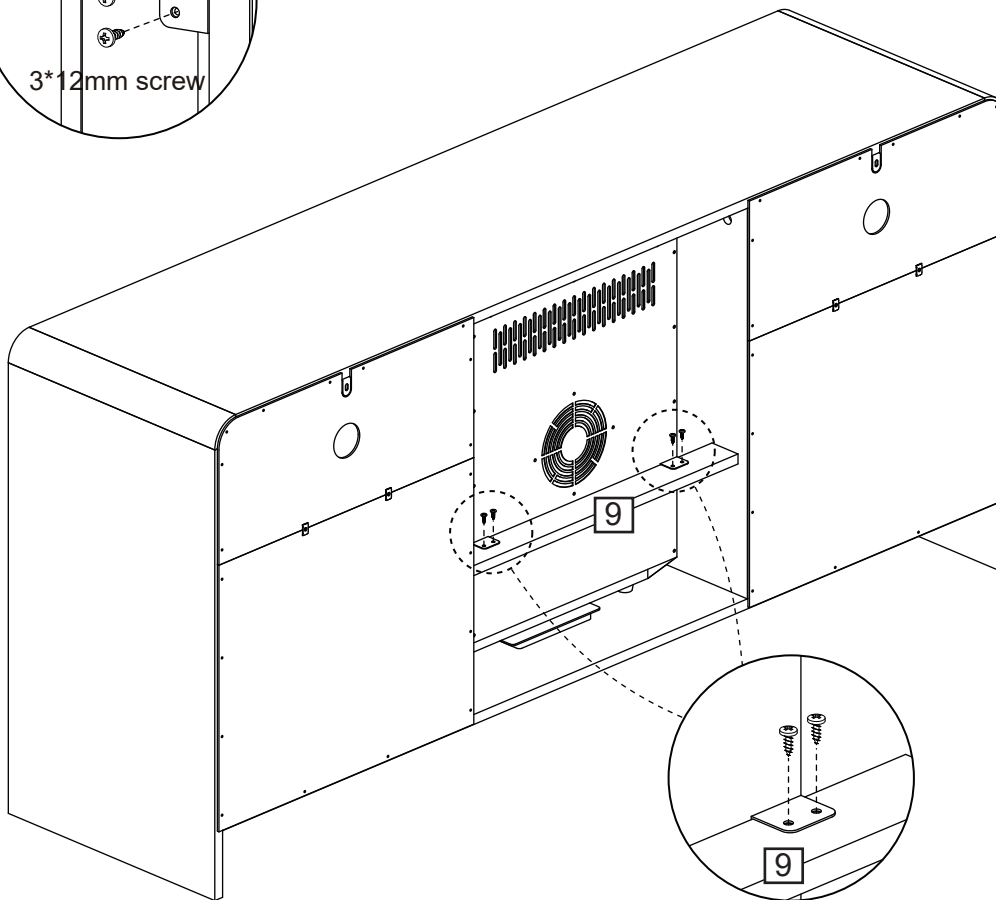

3*12mm screw

Assembly Instructions

Step 23

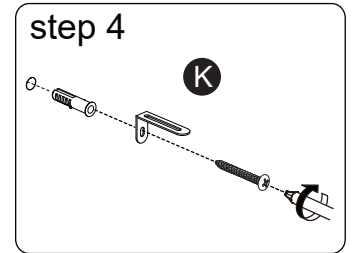
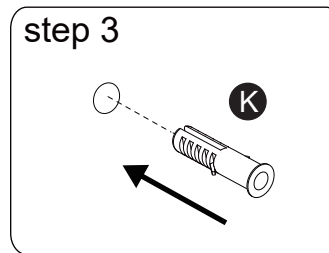
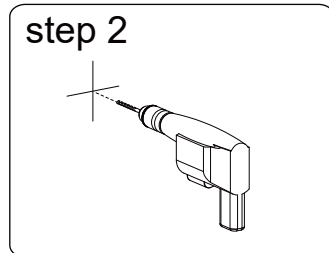
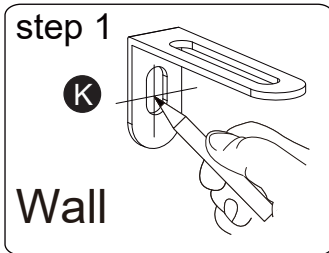
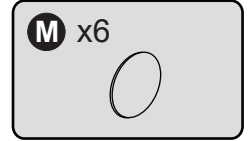
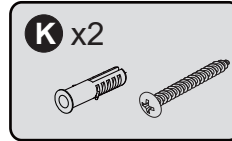

As shown, install the anti-tip device.

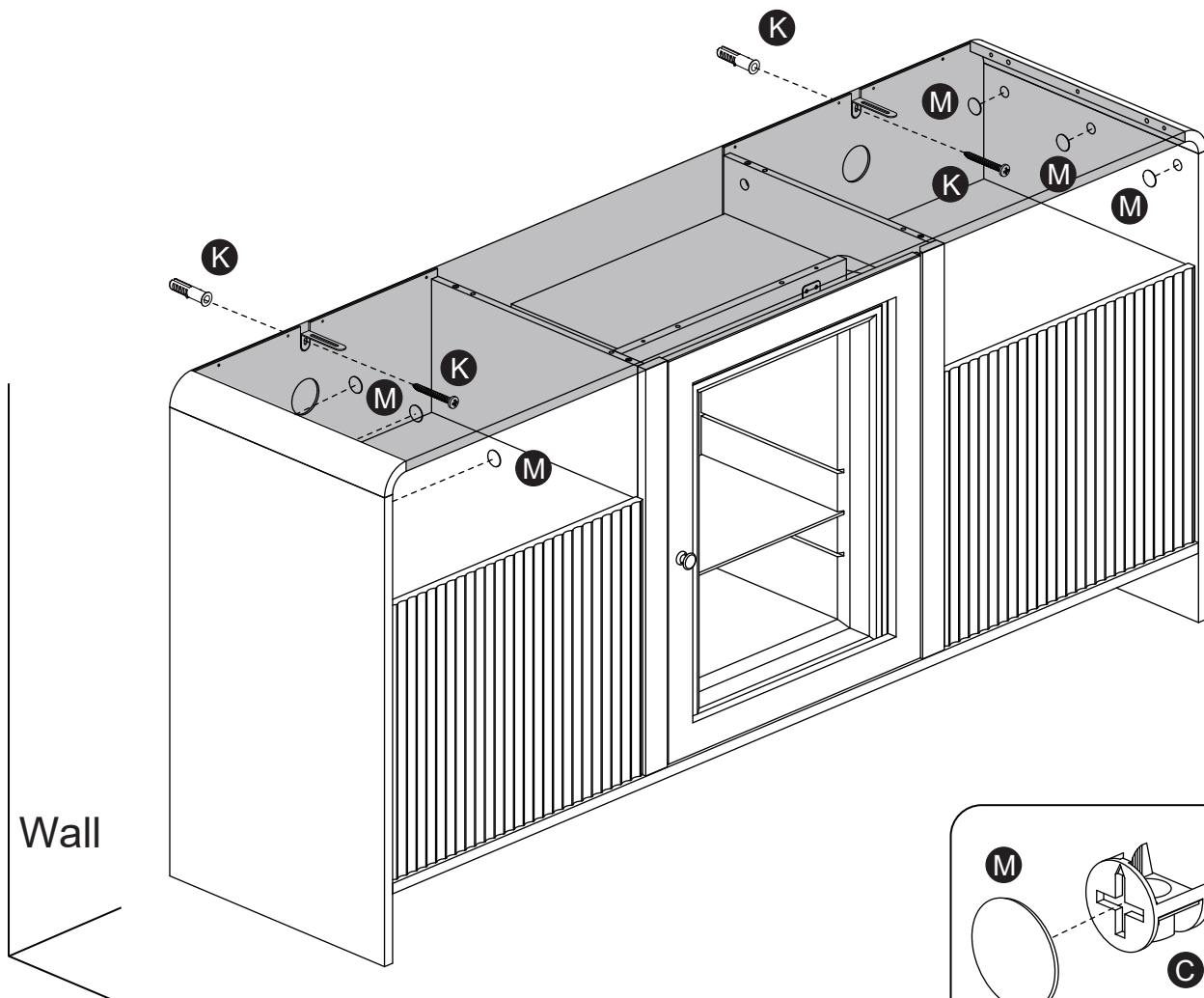

A Guide to Wall Mounting & Fixings

Important note:

If plastic wall plugs (rawl plugs) are supplied with your product, e.g.:



- these are only suitable for use in masonry walls.

If you are in any doubt about the correct wall plugs for your wall, seek professional advice.

Failure of the product due to using the incorrect fixings is the responsibility of the installer.



Important: when drilling into walls always check that there are no hidden wires or pipes etc.

Make sure that the screws and wall plugs being used are suitable for **supporting your unit**. **Consult a qualified tradesperson if you are unsure.**

Hints:

- 1: General rule:  always use a larger screw and wall plug if you are not sure.
- 2: Ensure you use the recommended drill bit to match the wall plug and hole size.
- 3: Ensure you drill the hole horizontally; do not force the drill or enlarge the hole.
- 4: Take extra care when drilling high walls, ceilings and ceramic tiles. Ensure wall plugs are inserted beyond the thickness of the ceramic tiles to avoid the tiles splitting or cracking.
- 5: Ensure wall plugs are well fitted and are a tight fit in the drilled hole.

Types of walls

You can use one of the following types of wall plug if your walls are made of brick, breeze block, concrete, stone or wood.

No.1 "General Purpose" wall plug

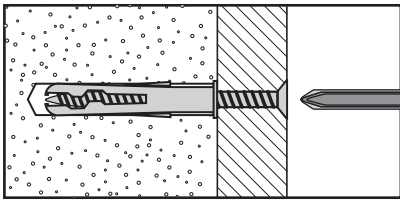

Generally aerated blocks should not be used to support heavy loads, use a specialist fitting in this case. For light loads, general purpose wall plugs can be used.

No.3 "Cavity Fixing" wall plug

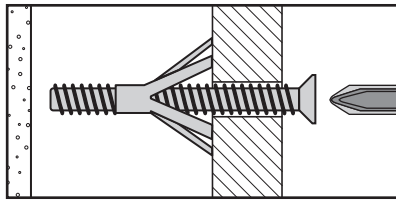

For use with plasterboard partitions or hollow wooden doors.

No.5 "Hammer Fixing" wall plug

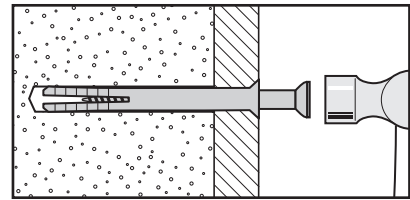

For use with walls stuck with plasterboard. The hammer fixing allows it to be fixed to the wall rather than the plasterboard. Always check the fixing is secure to the retaining wall.

No.2 "Plasterboard" wall plug

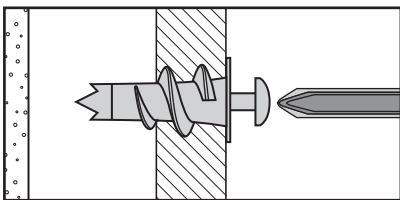

For use when attaching light loads onto plasterboard partitions.

No.4 "Cavity Fixing - Heavy Duty" wall plug

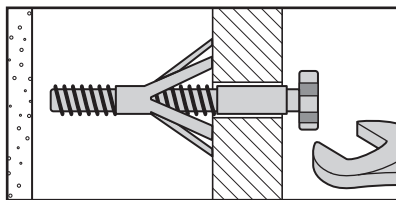

For use when fitting or supporting heavy loads such as shelving, wall cabinets and coat racks.

No.6 "Shield Anchor" wall plug - heavy loads

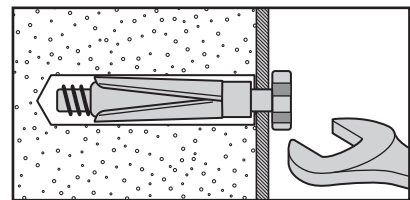

For use with heavier loads such as TV and HiFi speakers and satellite dishes etc.



Care & Maintenance

Safety: always check the fitting and location to ensure your safety in and around the home.

Fitting: from time to time check the fitting to ensure the wall plugs or screws do not become loose.