

Assembly Instructions

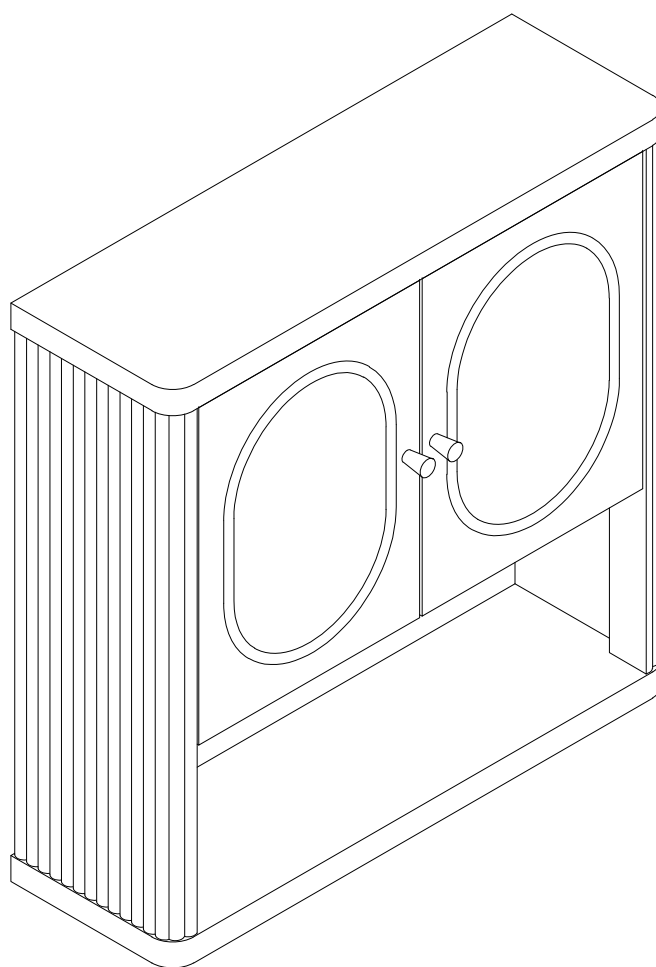

Before Assembly

Tips Before Your Start:

- Remove all wrapping material, including staples & packing straps before you start to assemble.
- DO NOT tighten all screws and bolts until the assembly is completely assembled.
- Keep all hardware parts out of reach of children.

QUICKFIT

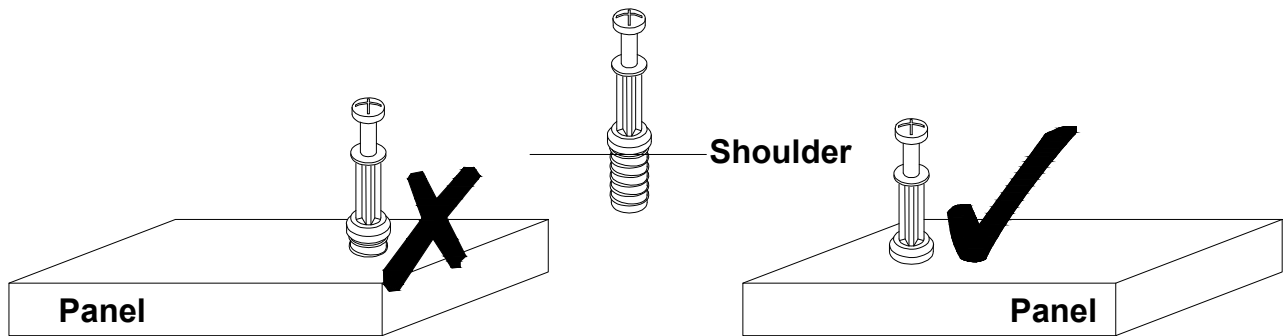

Tighten quickfit until shoulder is flush with panel. Do not overtighten or undertighten.

CAM LOCK

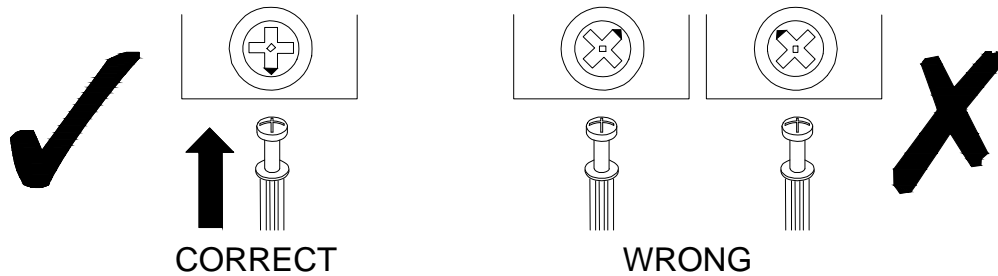

When fitting a cam lock, ensure the starting position is correct before inserting the connecting QUI CKFIT





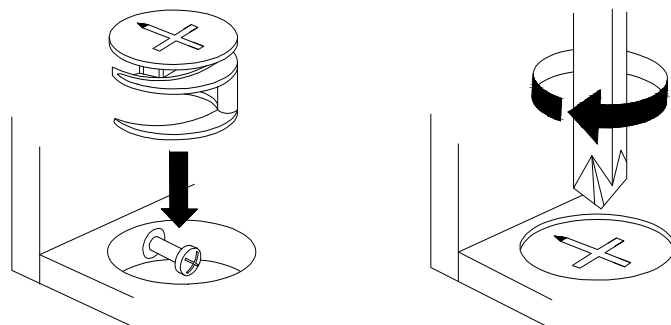



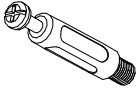

Quickfit head should be in the centre of the cam lock when the two panels are joined.

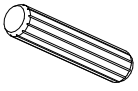
Cam lock should be inserted before quickfit.

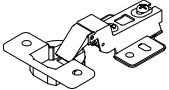

Turn cam lock clockwise to tighten.

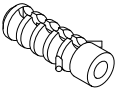
Part List

<p>No. A Quantity: 20 Pcs Cam Lock Dowel 8*28mm</p> 	<p>No. B Quantity: 20 Pcs Cam 15</p> 	<p>No. C Quantity: 20 Pcs Sticker Ø20</p> 	<p>No. D Quantity: 9 Pcs Dowel 8*30mm</p> 
<p>No. E Quantity: 24 Pcs Screw 3.5*14mm</p> 	<p>No. F Quantity: 2 Pcs Screw M4*20mm</p> 	<p>No. G Quantity: 2 Pcs Handle</p> 	<p>No. H Quantity: 4 Pcs Hinge</p> 
<p>No. I Quantity: 6 Pcs Shelf Support M5*15mm</p> 	<p>No. J Quantity: 10 Sets Plastic Wedge</p> 	<p>No. K Quantity: 3 Pcs Expansion bolt M8*40mm</p> 	<p>No. L Quantity: 3 Pcs Screw M5*60mm</p> 

Product structure

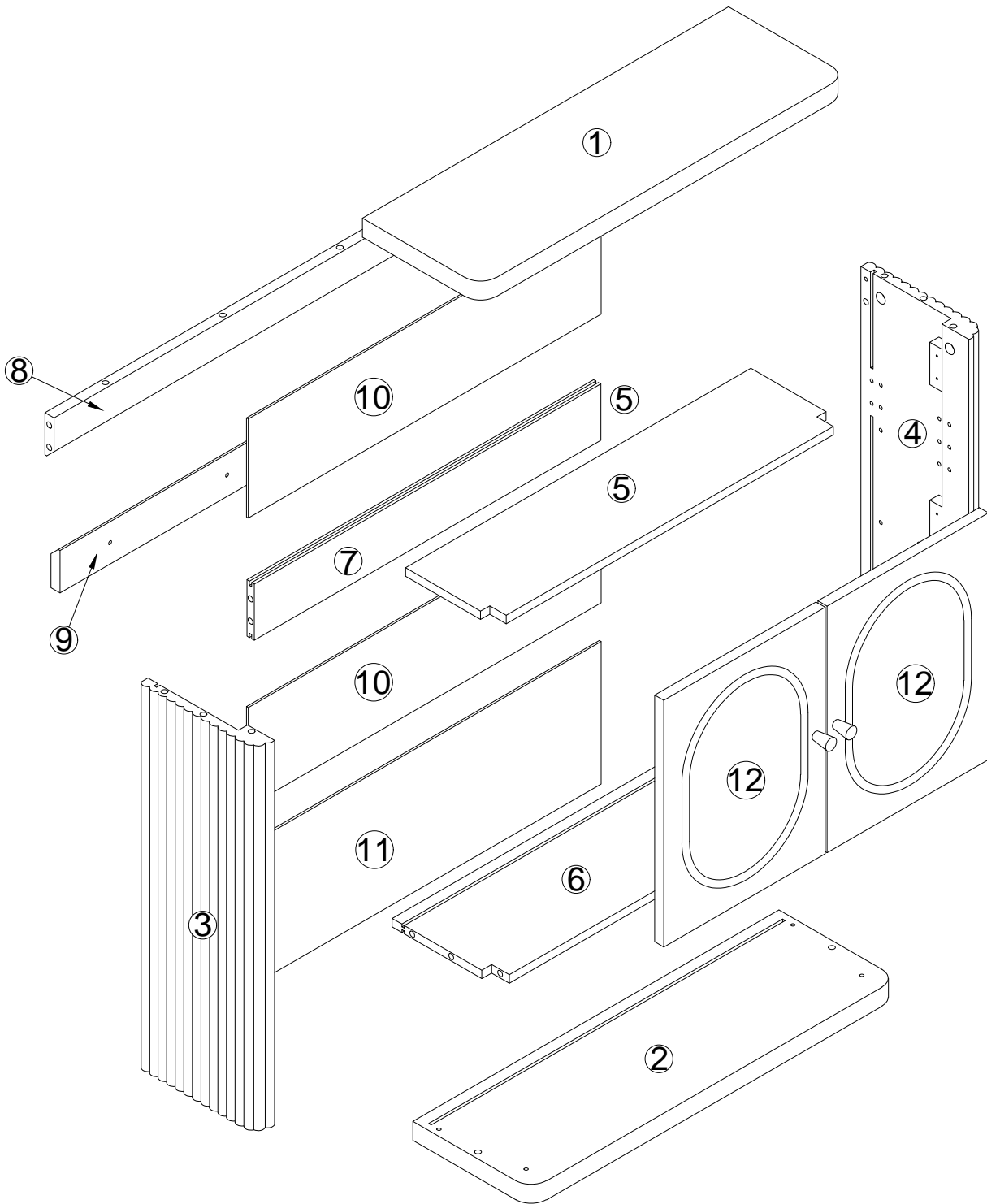

STEP 1

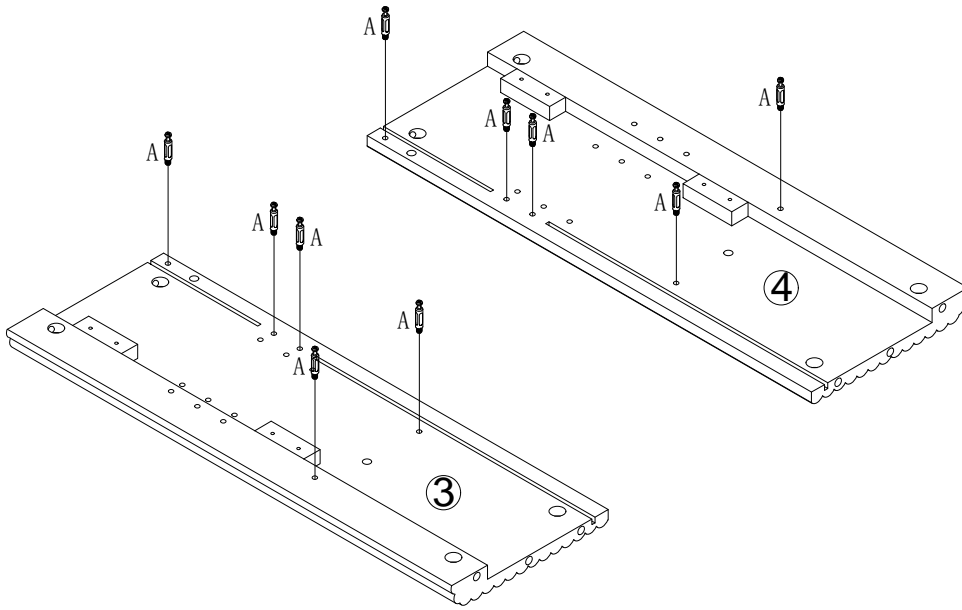

No. A
Quantity: 10 Pcs
8*28 mm



STEP 2

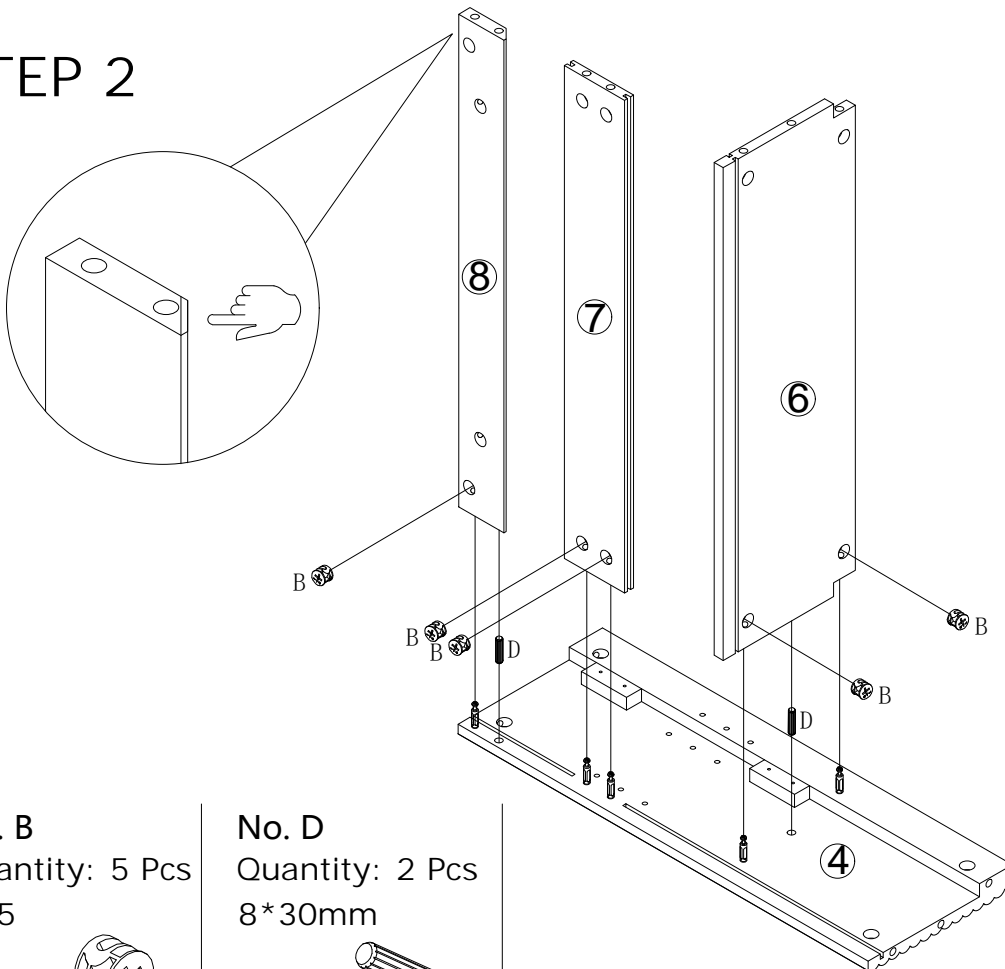

No. B
Quantity: 5 Pcs
Ø15



No. D
Quantity: 2 Pcs
8*30mm

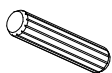

STEP 3

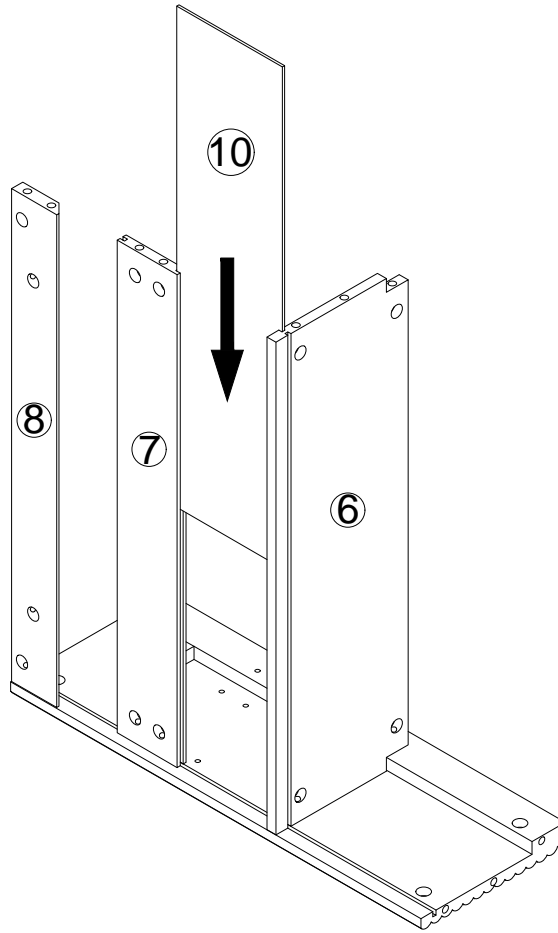

STEP 4

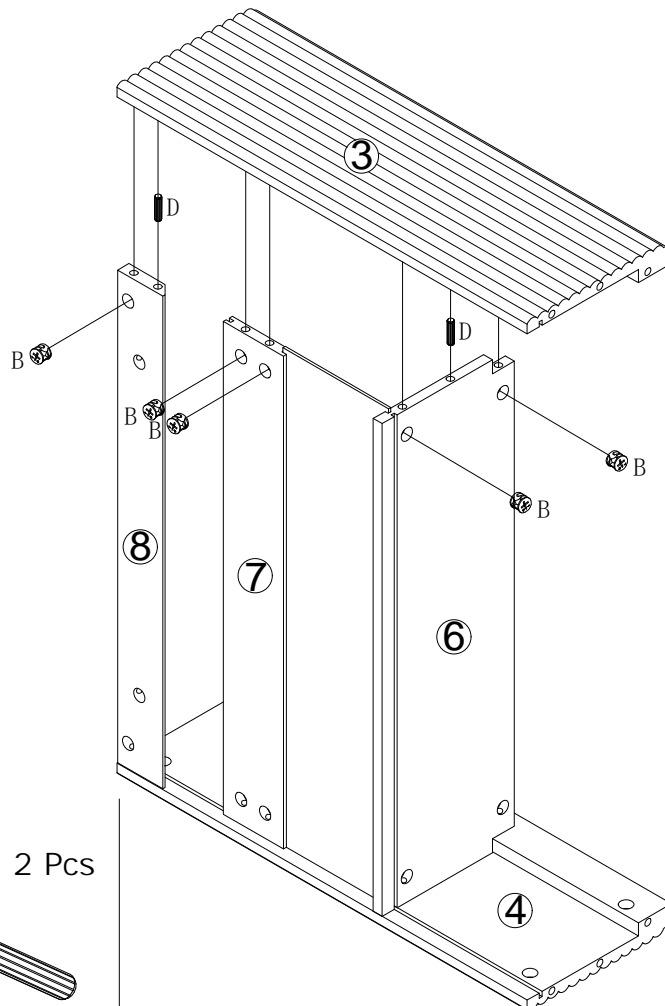

No. B
Quantity: 5 Pcs
Ø15



No. D
Quantity: 2 Pcs
8*30mm

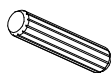

STEP 5

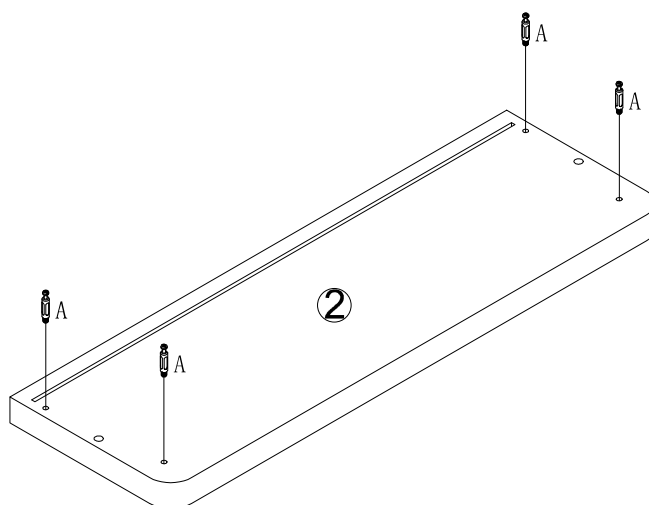

No. A
Quantity: 4 Pcs
8*28 mm



STEP 6

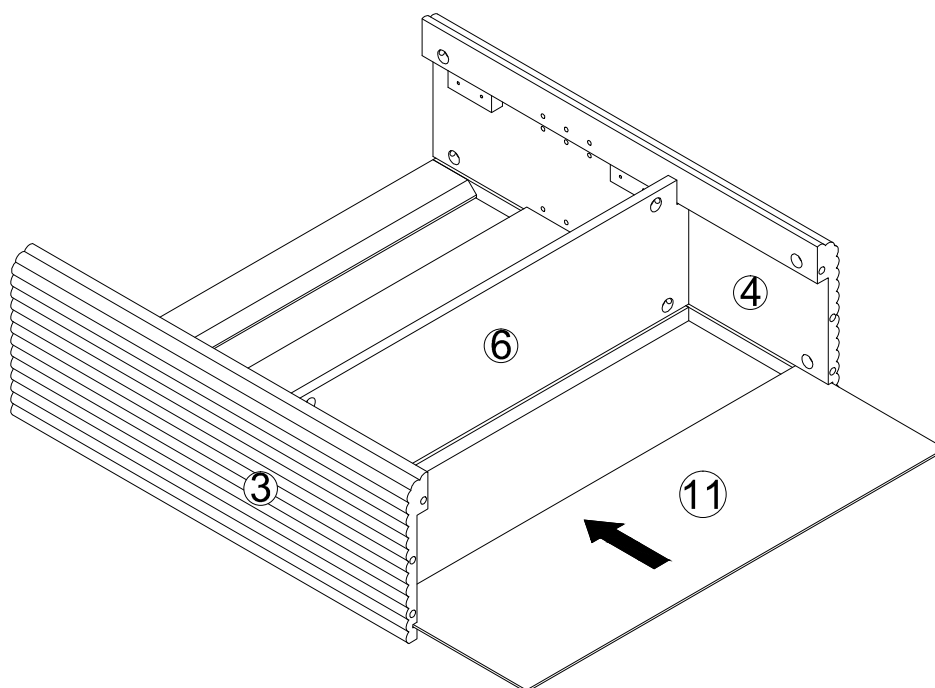

STEP 7

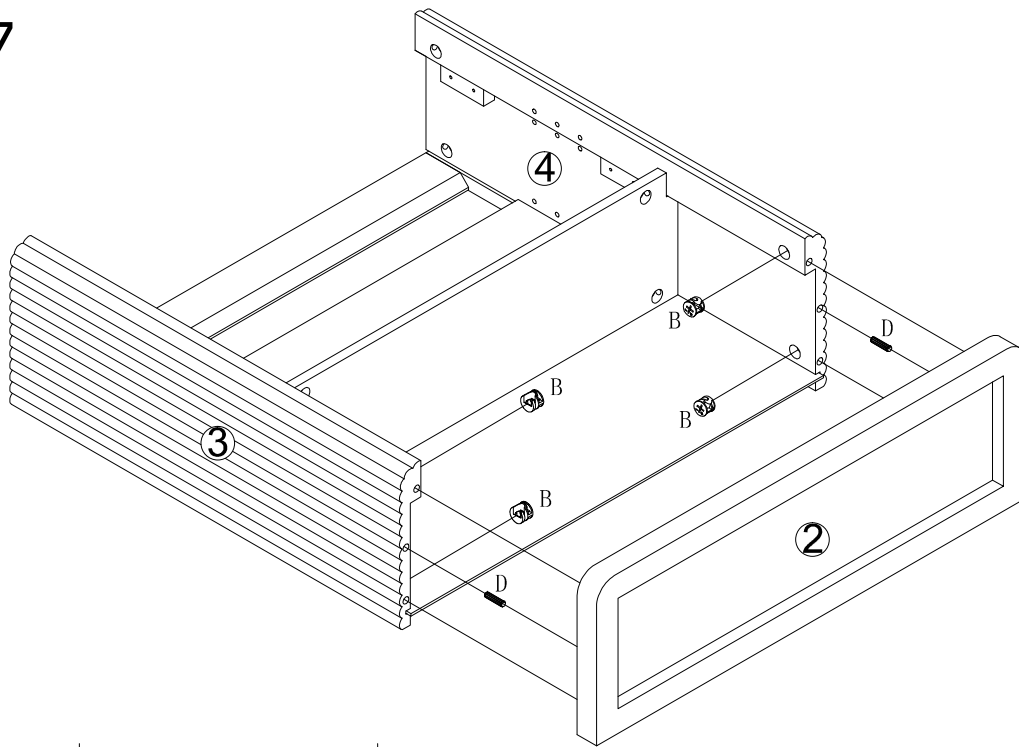

No. B
Quantity: 4 Pcs
Ø15



No. D
Quantity: 2 Pcs
8*30mm

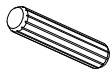

STEP 8

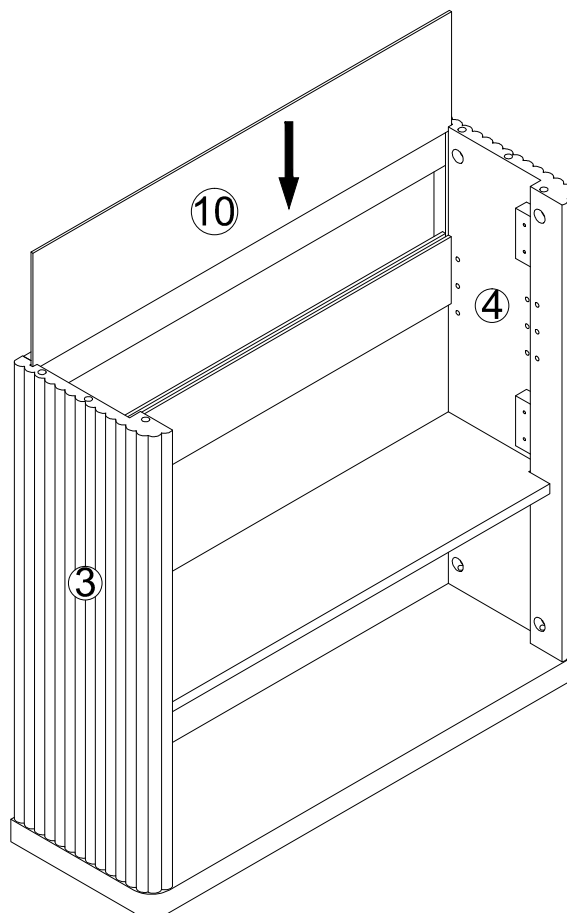

STEP 9

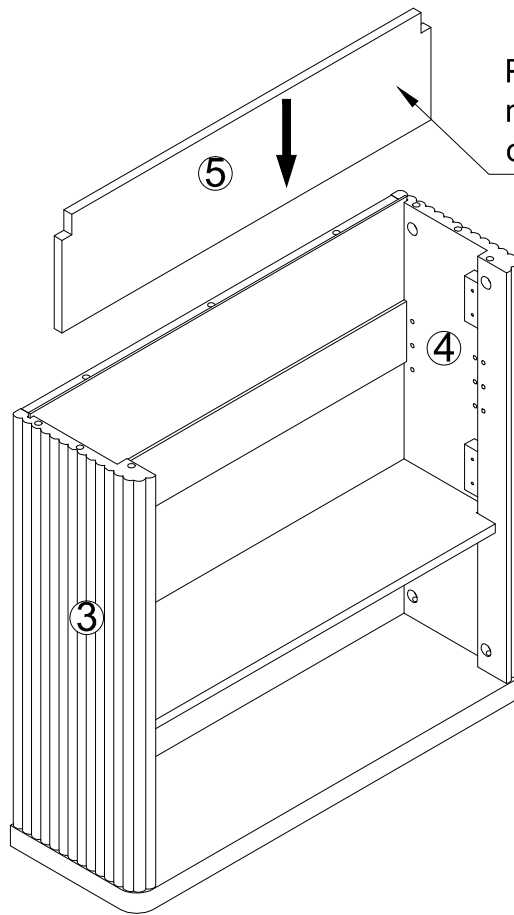

Please note that you need to put the part numbered 5 into the cabinet first, otherwise it may lead to assembly failure!

STEP 10

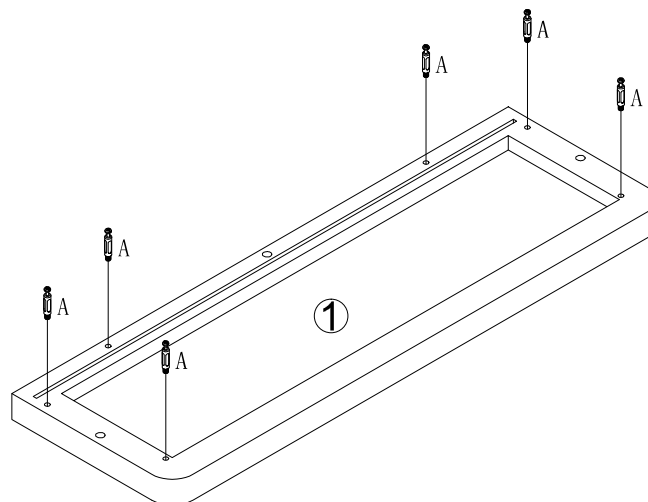

No. A
Quantity: 6 Pcs
8*28 mm



STEP 11

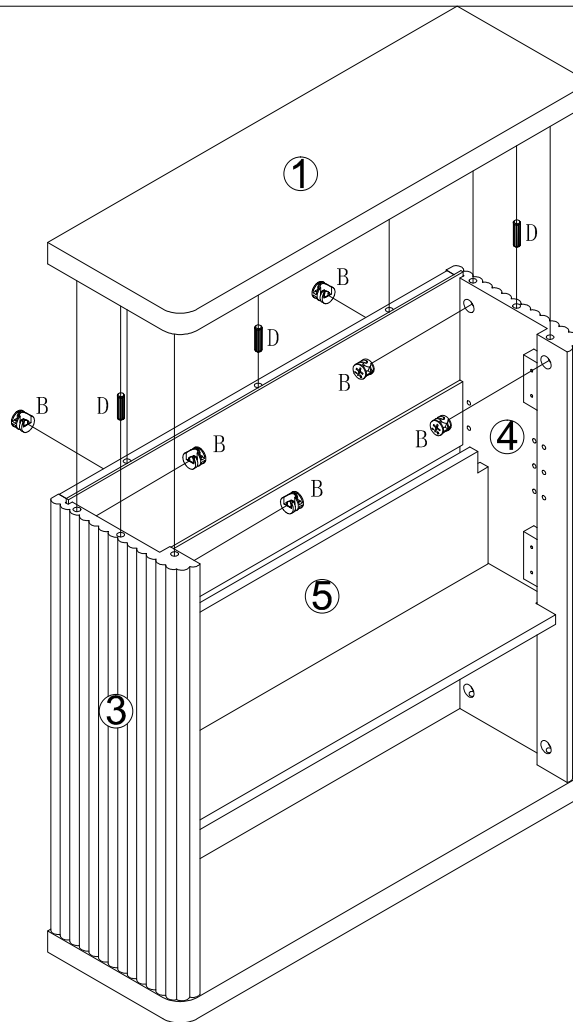

No. B
Quantity: 6 Pcs
Ø15



No. D
Quantity: 3 Pcs
8*30mm

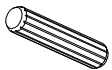

STEP 12

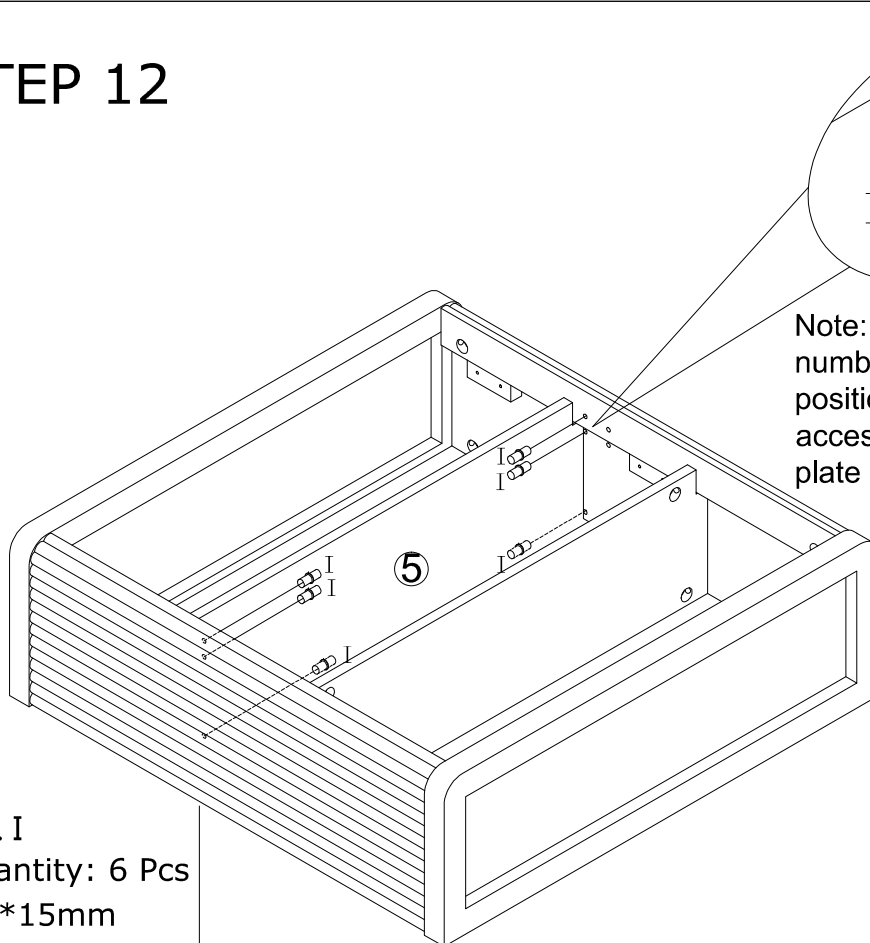

Note: First adjust the movable panel numbered 5 to the appropriate position, and then place the hardware accessories of the movable layer plate into the corresponding holes.

No. I
Quantity: 6 Pcs
M5*15mm



STEP 13

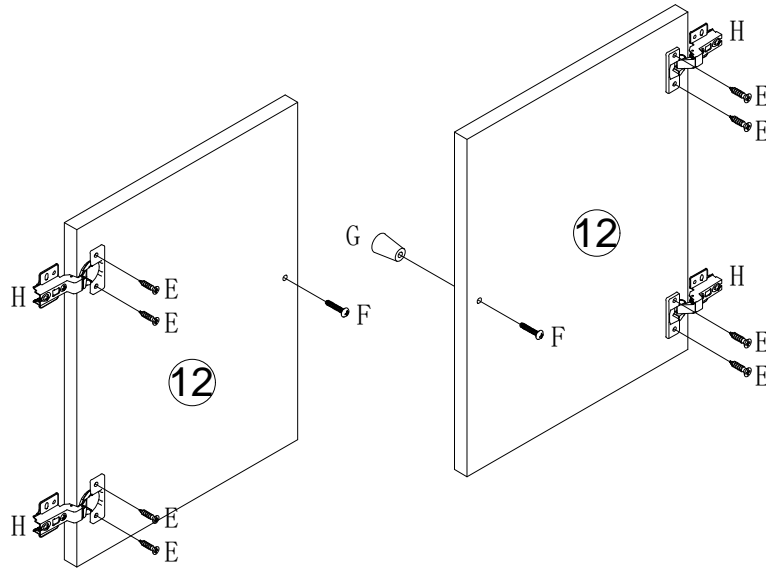

No. E
Quantity: 8 Pcs
3.5*14mm



No. F
Quantity: 2 Pcs
M4*20mm



No. G
Quantity: 2 Pcs



No. H
Quantity: 4 Pcs

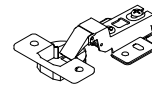

STEP 14

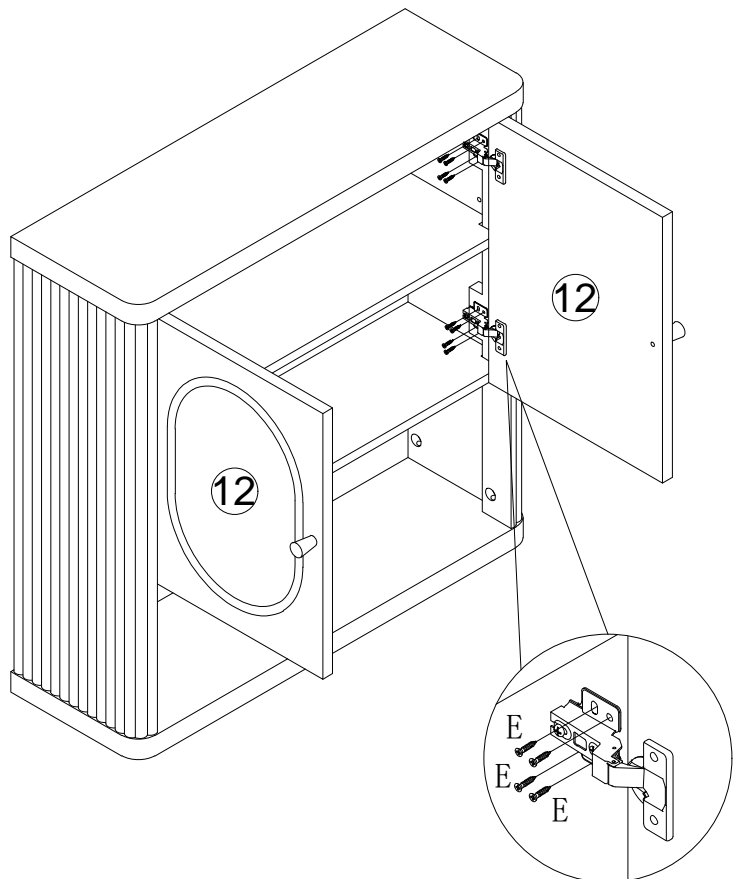
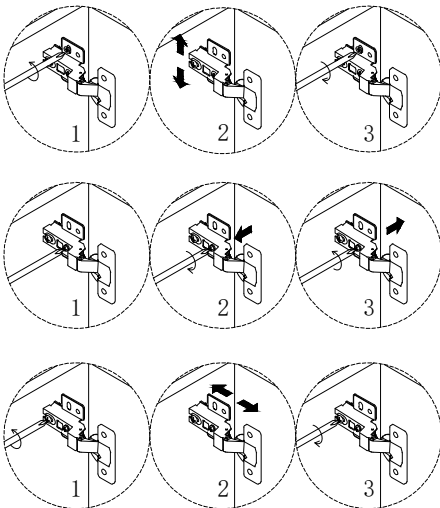

No. E
Quantity: 16 Pcs
3.5*14mm



STEP 15

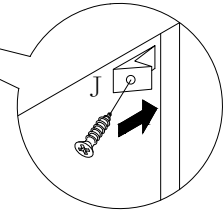
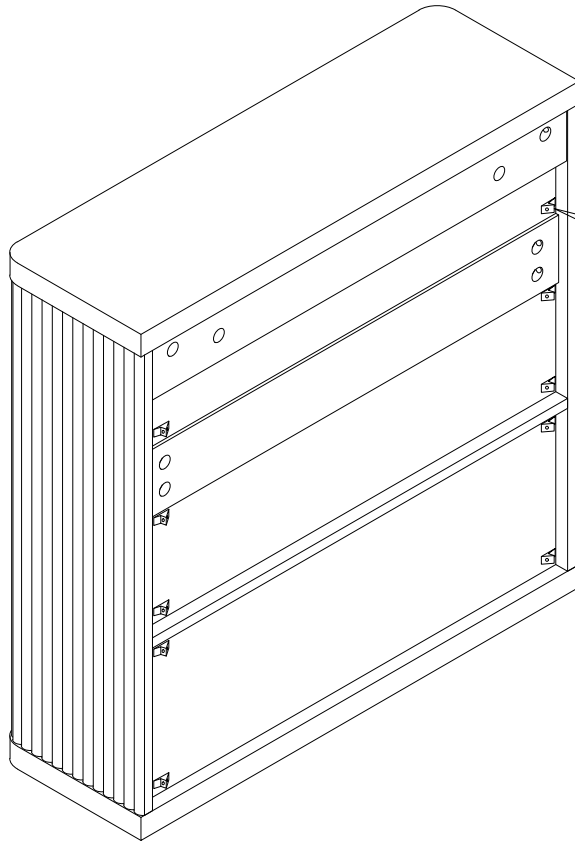

Description: Insert the thinner end of the reinforcement into the gap in this back panel, then tighten the screws. This will make the cabinet more stable.

No. J
Quantity: 10 Sets

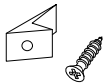

STEP 16

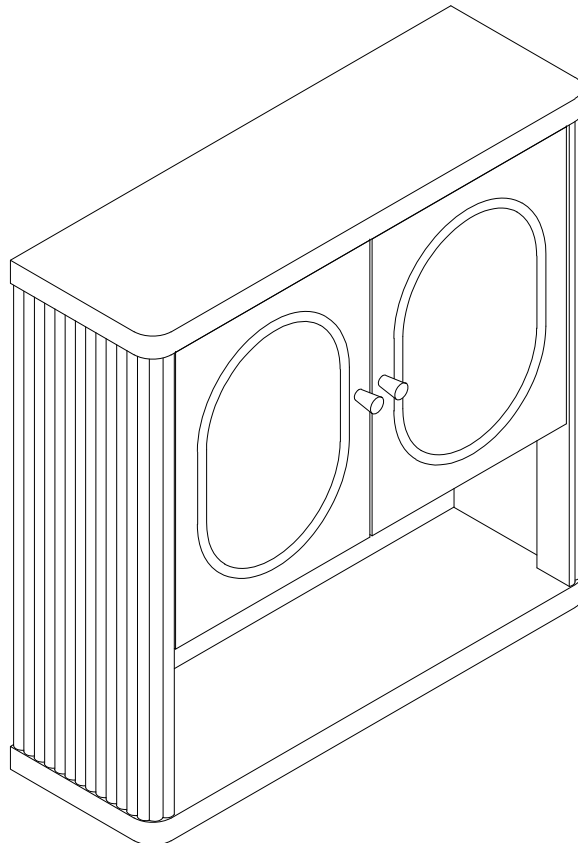

STEP 17

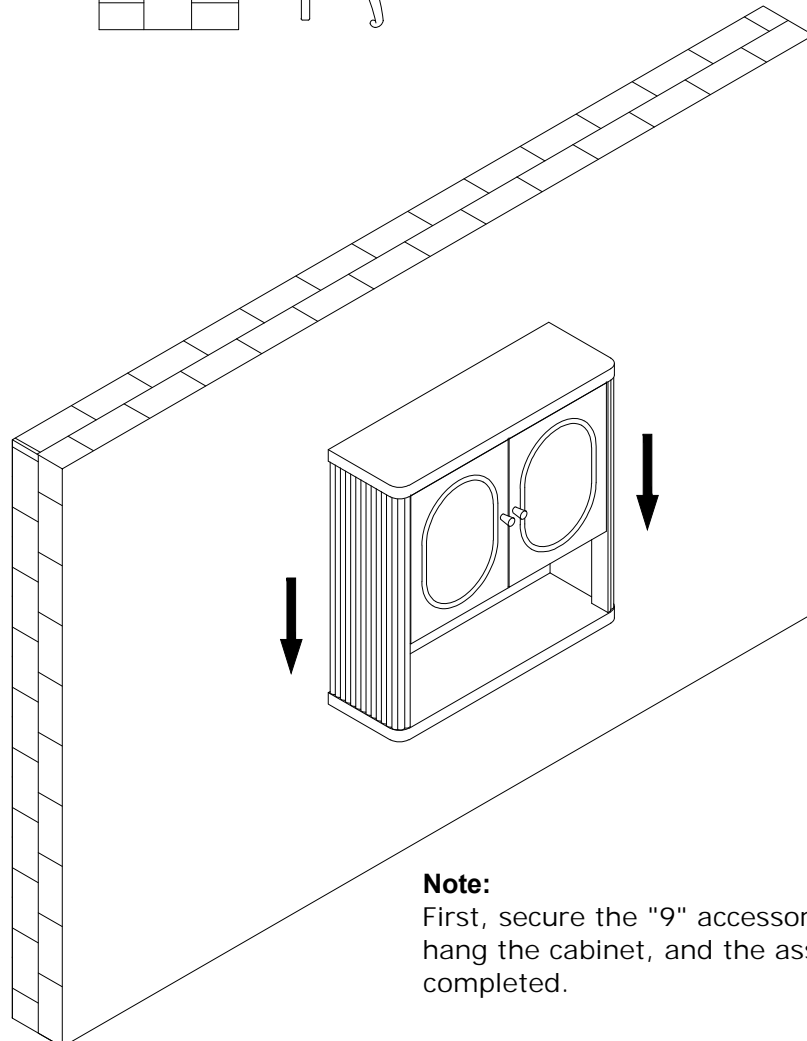
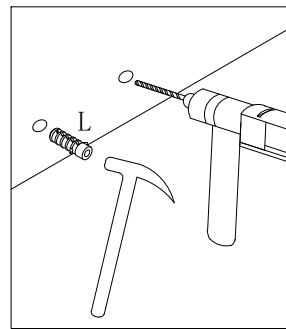
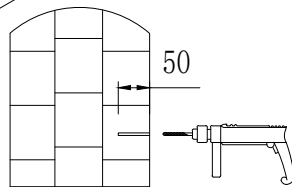
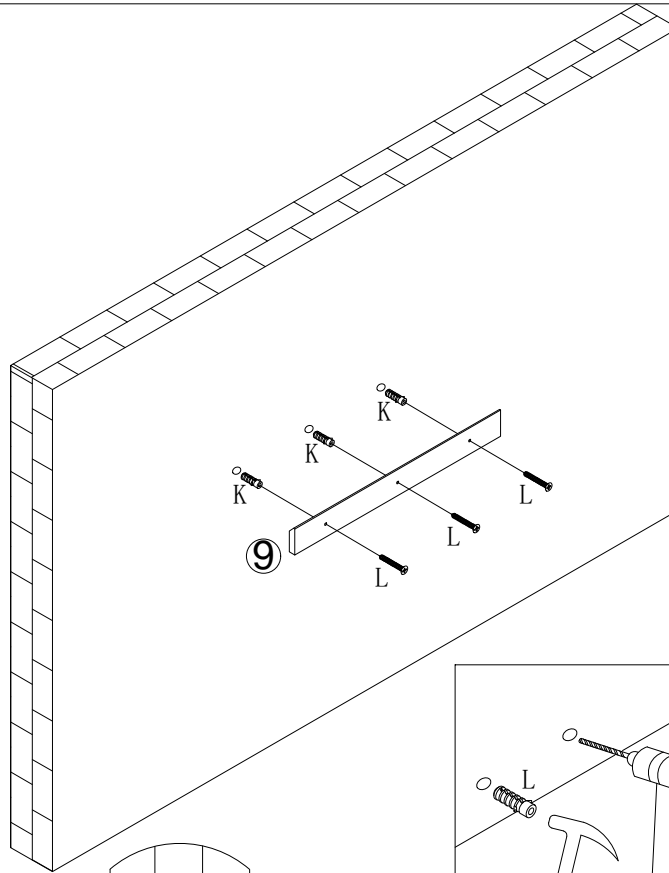

No. L

Quantity: 3 Pcs
M5*60mm

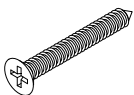

No. K

Quantity: 3 Pcs

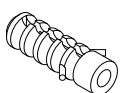

Note:

First, secure the "9" accessories, then hang the cabinet, and the assembly is completed.