

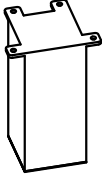

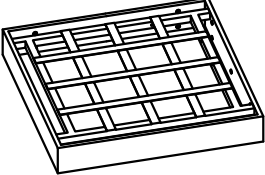
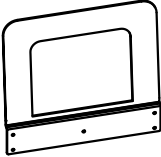
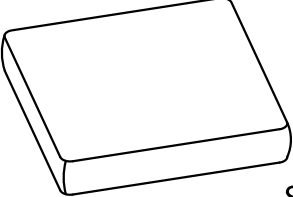

Assembly Instructions

Please read this before you proceed.

NUMBER	COMPONENT	QUANTITY
A	 <p>Sofa Leg</p>	4PCS
B	 <p>Sofa Seat</p>	1PC
C	 <p>Aluminum Backrest Panel</p>	1PC
D	 <p>Seat Cushion</p>	1PC
E	 <p>Backrest Cushion</p>	1PC

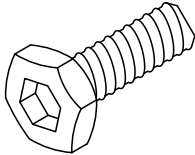
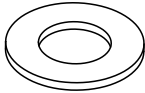
Assembly Instructions

NUMBER	COMPONENT	QUANTITY
AA	 <p data-bbox="676 475 841 507">Bolt M6*20</p>	17+2PCS
BB	 <p data-bbox="613 683 841 715">M6 Flat washer</p>	17+2 PCS
CC	 <p data-bbox="650 885 841 917">M6 Allen Key</p>	1PC

Assembly Instructions

①

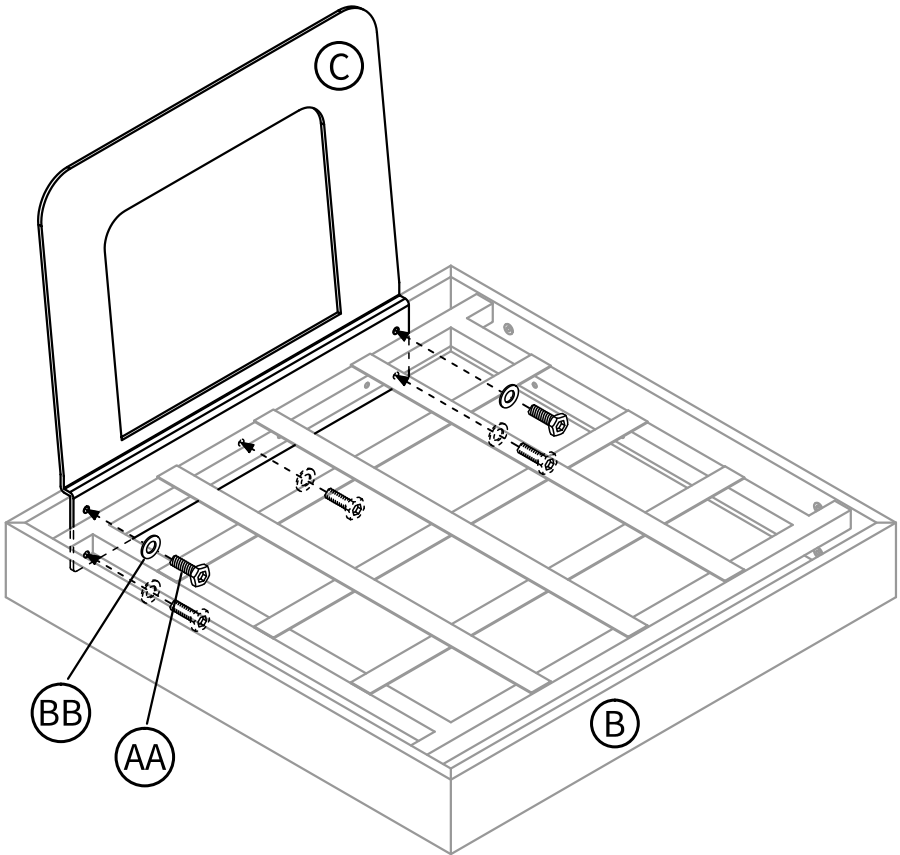

Place the Sofa Seat (B) on the surface with the seat support straps facing up. Attach one (1) Aluminum Backrest Panel (C) to a side of the Sofa Seat (B) using two (2) M6*20 Bolts (AA) and two (2) M6 Flat Washers (BB) on each end. Add one (1) more M6*20 Bolt (AA) with one (1) M6 Flat Washer (BB) in the center.

Assembly Instructions

2

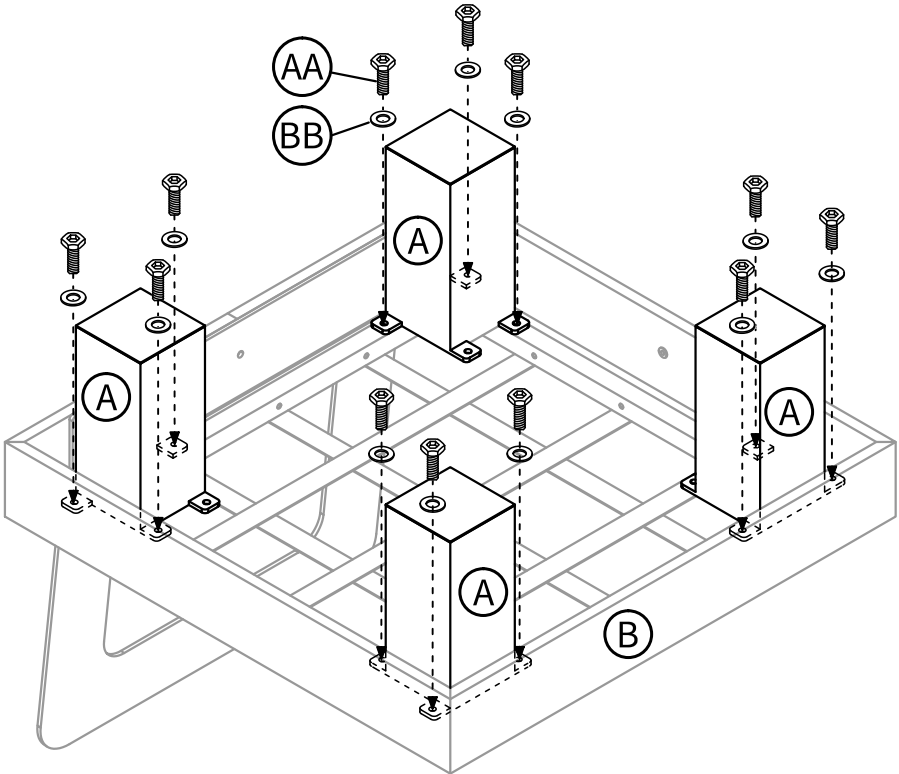

To maintain consistency across all legs, an additional hole has been added. Please disregard the use of this extra hole. Thank you!

Flip the assembly from Step 1 over. Attach one (1) Sofa Leg (A) in each corner using three (3) M6*20 Bolts (AA) and three (3) M6 Flat Washers (BB) for each leg.

Assembly Instructions

③

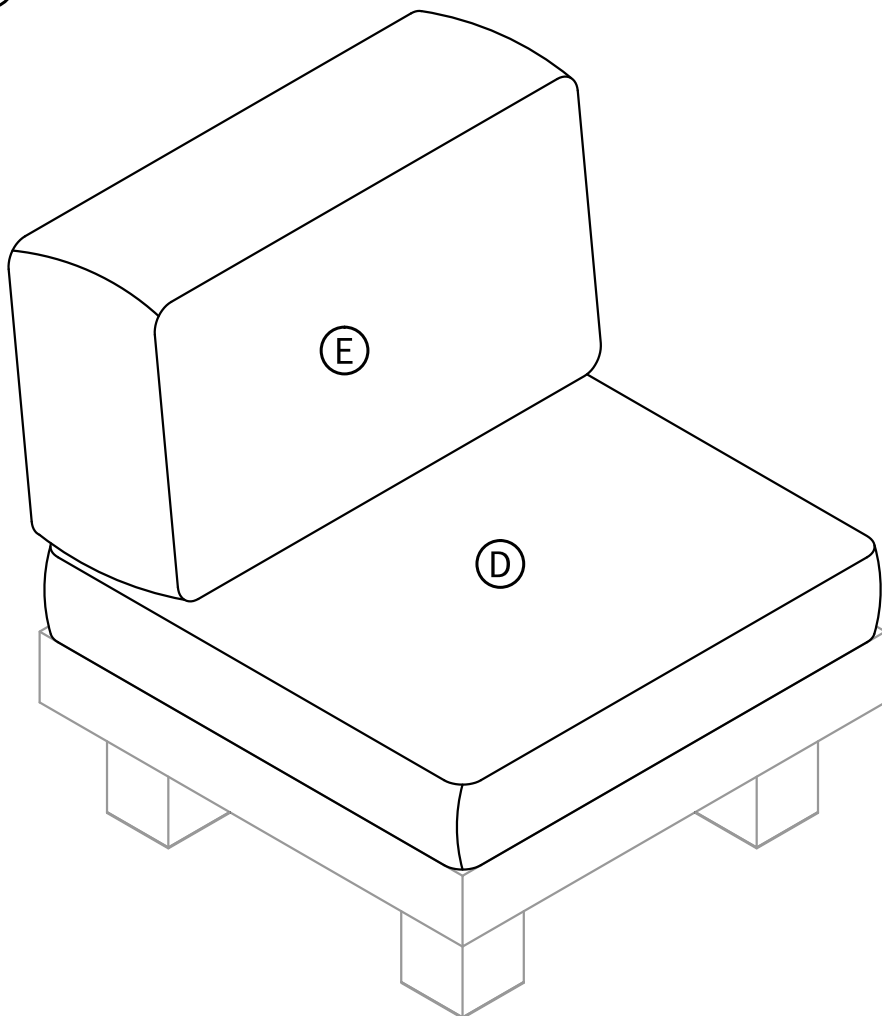

Flip the assembly from Step 2 over. Place the Seat Cushion (D) onto the Sofa Seat (B). Then, place the Backrest Cushion (E) up against the Aluminum Backrest Panel (C).