



VESTIL MANUFACTURING COMPANY

2999 North Wayne Street, P.O. Box 507, Angola, IN 46703

Telephone: (260) 665-7586 -or- Toll Free (800) 348-0868

Fax: (260) 665-1339

www.vestil.com info@vestil.com

E-MT MANUAL TROLLEYS & E-MT-C CHAIN DRIVE TROLLEYS



Receiving instructions

After delivery, remove the packaging from the product. Inspect the product closely to determine whether it sustained damage during transport. If damage is discovered, record a complete description of it on the bill of lading. If the product is undamaged, discard the packaging.

NOTE: The end-user is solely responsible for confirming that product design, use, and maintenance comply with laws, regulations, codes, and mandatory standards applied where the product is used.

Technical Service & Replacement Parts

For answers to questions not addressed in these instructions and to order replacement parts, labels, and accessories, call our Technical Service and Parts Department at (260) 665-7586. The department can also be contacted online at <https://www.vestil.com/page-parts-request.php>.

Electronic Copies of Instruction Manuals

Additional copies of this instruction manual may be downloaded from <https://www.vestil.com/page-manuals.php>.

Table of Contents		Page
Signal Words.....		2
Safety Instructions.....		2
Exploded View and Bill of Materials.....		3
Installing the Trolley.....		4
Using the Trolley.....		4
Record of Satisfactory Condition.....		5
Load Tests.....		5
Inspections & Maintenance.....		5 - 6
Labeling Diagram.....		6
Limited Warranty.....		7

SIGNAL WORDS

SIGNAL WORDS in this manual draw the reader's attention to important safety-related messages.

⚠ DANGER

Identifies a hazardous situation which, if not avoided, **WILL** result in **DEATH** or **SERIOUS INJURY**. Use of this signal word is limited to the most extreme situations.

⚠ WARNING

Identifies a hazardous situation which, if not avoided, **COULD** result in **DEATH** or **SERIOUS INJURY**.

⚠ CAUTION

Indicates a hazardous situation which, if not avoided, **COULD** result in **MINOR** or **MODERATE** injury.

NOTICE

Identifies practices likely to result in product/property damage, such as operation that might damage the product.

SAFETY INSTRUCTIONS

Vestil strives to identify all foreseeable hazards associated with the use of its products, but no manual can address every conceivable risk. Prevent injury by applying sound judgment whenever using this device. Acquire a copy of the latest version of ITSDF/ANSI B56.1 ("B56.1" or the "Standard"). The Standard is freely downloadable on www.ITSDF.org. Apply all portions of Part II "For the User" about the use of attachments and removable attachments. The following instructions complement provisions of B56.1.

⚠ DANGER

Electrocution might result if any part of the product contacts electrified wires. Reduce the likelihood of electrocution by applying **common sense**:

- DO NOT *contact* electrified wires with any part of this device, your body, or clothing.
- DO NOT use or store the product where contact with electrified wires is likely.
- Always inspect the usage area before using the product & implement precautions that account for conditions.

⚠ WARNING

Unsafe use of this product could result in serious personal injuries or death.

- *Read and understand the entire manual before assembling, installing, using or servicing the product.* Read the manual to refresh your understanding of proper use and maintenance procedures. Maintenance personnel must read the manual before servicing the trolley.
- Routinely read the manual to refresh your understanding of proper use and maintenance procedures. Keep a copy of the manual in a location known to and accessible by, all users of this trolley.
- DO NOT attempt to resolve any issues with the product unless you are authorized and qualified to work on equipment of this type.
- DO NOT use this trolley to suspend or move people or equipment that supports people (e.g. work platforms)! This trolley is designed for material handling only.
- DO NOT lift loads over people.
- DO NOT modify the trolley in any way. **Unapproved modifications automatically void the LIMITED WARRANTY (see p. 7) and might make the product unsafe to use.**
- DO NOT exceed the capacity of your trolley. The combined weights of all items attached to the trolley must be equal to or less than the capacity of the trolley.
- Inspect the trolley as instructed in the [INSPECTIONS & MAINTENANCE](#) section on p. 5-6. DO NOT use the device unless it is in satisfactory condition. If you observe any damage, such as but not limited to warping or cracking of the equalizer pin, tag the unit "Out of Service" and report the damage to maintenance personnel. DO NOT use the trolley until it is completely restored to satisfactory condition.
- Slowly move the load with the trolley and avoid impacts that might damage the trolley.
- DO NOT get between the load and objects such as walls or ceiling supports while moving the load.
- DO NOT leave a suspended load unattended. Always return the load to the ground and confirm that it is stable before leaving.
- DO NOT use this device UNLESS all product labels are readable and undamaged. See [LABELING DIAGRAM](#) on p. 6.

NOTICE

Proper use, maintenance, and storage are essential for this product to function properly.

- Always use this product in accordance with the instructions in this manual and consistent with any training relevant to machines, devices, etc. used in conjunction with this product.
- Keep the product clean & dry.

EXPLODED VIEW AND BILL OF MATERIALS

E-MT-1, E-MT-1-C
 E-MT-2, E-MT-2-C
 E-MT-4, E-MT-4-C (2016)
 E-MT-6, E-MT-6-C
 E-MT-8, E-MT-8-C

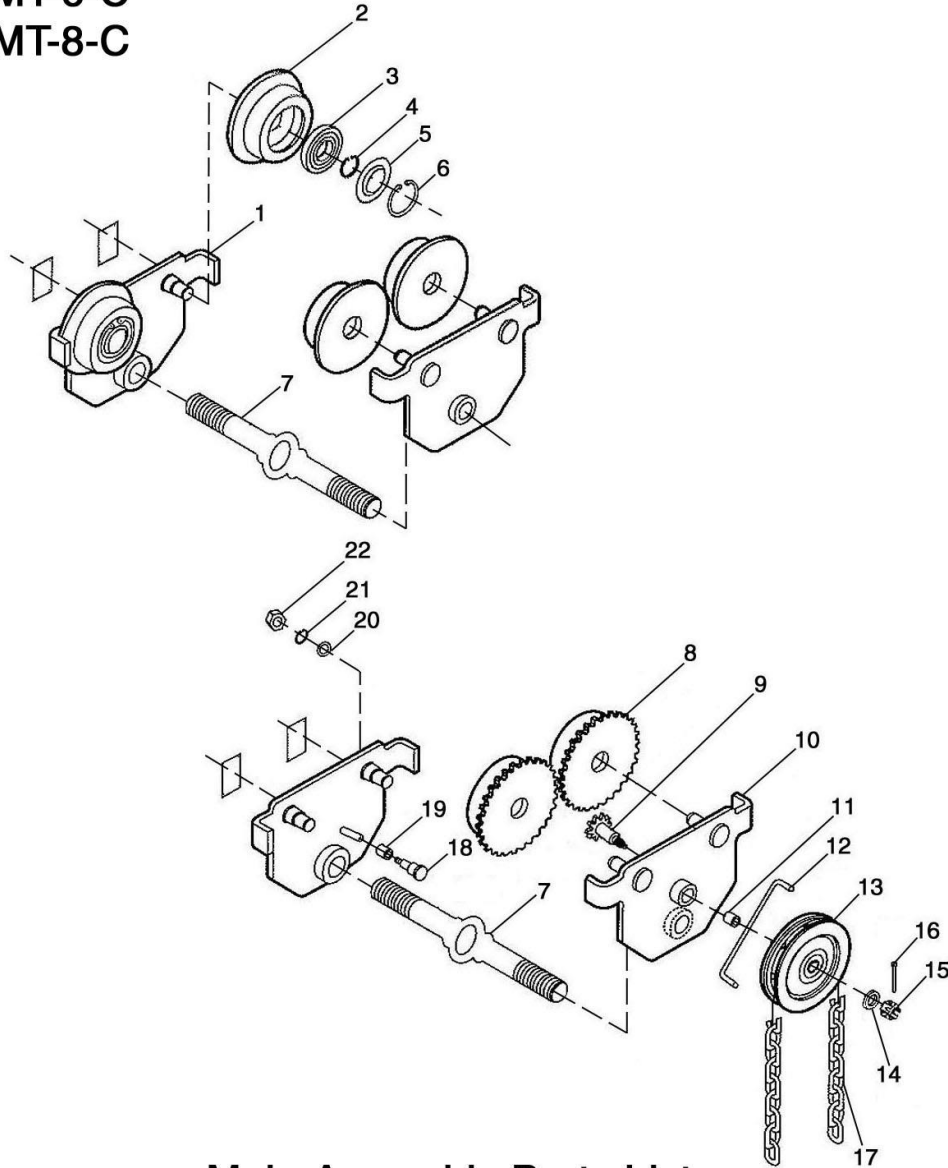

Main Assembly Parts List

Part No.	Description	Q'ty	Part No.	Description	Q'ty
E-MT-16-1	Assembly, Left Gear Case	2	E-MT-16-12	Pin, Catch	1
E-MT-16-2	Wheel, Drive	1	E-MT-16-13	Wheel, Chain	1
E-MT-16-3	Bearing	1	E-MT-16-14	Washer, Spacer	1
E-MT-16-4	Ring, Axle	1	E-MT-16-15	Nut, Castle Hex	1
E-MT-16-5	Ring, Bearing	1	E-MT-16-16	Pin, Split	1
E-MT-16-6	Ring, Hole	1	E-MT-16-17	Chain (only applies to -C models)	1
E-MT-16-7	Pin, Equalizer	1	E-MT-16-18	Spindle, Roll	1
E-MT-16-8	Gear, Tooth	2	E-MT-16-19	Sleeve, Roll	1
E-MT-16-9	Spindle, Drive	1	E-MT-16-20	Sleeve, Axle	1
E-MT-16-10	Assembly, Right Gear Case	2	E-MT-16-21	Washer, Spring	1
E-MT-16-11	Sleeve, Copper	1	E-MT-16-22	Nut, Hex	1

INSTALLING THE TROLLEY

⚠ WARNING

DO NOT install, or use, this product on a beam unless there are stops at the end of the beam. Without stops, the trolley might roll off of the beam.

Before installing the manual trolley, the user should acquire a copy of the most recent revision of US national standard ASME B30.17 (the "Standard"). Apply all provisions of the Standard that are relevant to the installation of manual trolleys.

Part names and numbers appearing in these instructions correspond to the descriptions and numeral(s) after the last hyphen of the part numbers in the *Main Assembly Parts List* on p. 3. For example, "Pin, Equalizer" is part no. E-MT-16-7 in the *Main Assembly Parts List*. In the following instructions, it is referred to as "Equalizer Pin, (7)".

The following diagram depicts a cross-sectional view of the trolley installed on the bottom flange of an S-flange I-beam.

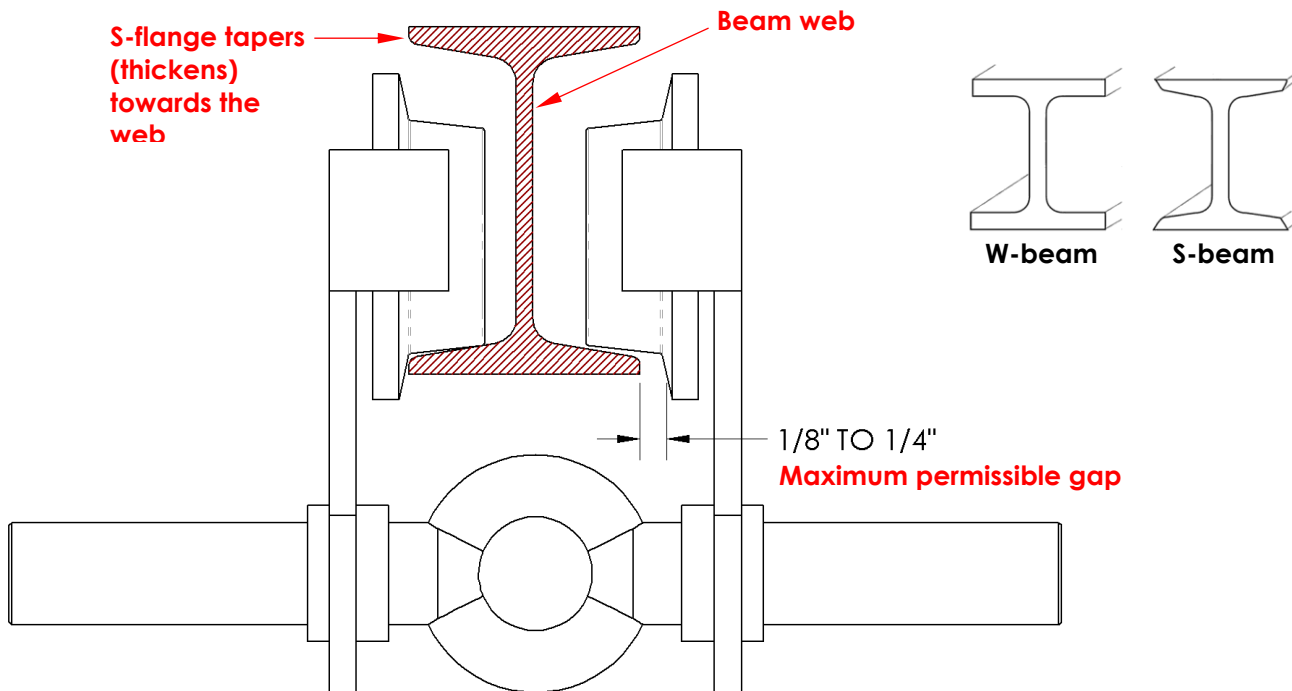

E-MT manual trolleys are designed for use with S, I, and W type I-beams, or a patented form of Rail beams depicted in ASME B30.17 (acceptable).

Spin the Equalizer Pin, (7), until the clearance between the Drive Wheels, (2) and (8), exceeds the width of the beam. Take care not to spin either Gear Case, (1) and (10), off the end of the Pin.

Lift the Trolley in place on the beam. Shift the Trolley to one side so that the beam flange contacts the Drive Wheel flanges on one side of the Trolley. Spin the Equalizer Pin until there is 1/8" to 1/4" (3.2mm to 6.4mm) clearance between the Drive Wheels on the opposite side of the Trolley.

USING THE TROLLEY

Trolleys without chains and tooth gears, i.e. models E-MT-##, are moved purely by manual power. To move the trolley, apply a steady pulling force to the load hook of the hoist attached to the trolley. Only release the load when it is centered beneath the trolley to prevent the load from swinging.

Trolleys with hand chains, i.e. model numbers E-MT-##-C, are also moved by manual effort. However, effort is transmitted to the tooth gears through a gear system. To move the trolley, pull the chain one way or the other. As the chain interacts with the chain wheel, the spindle rotates, and the spindle causes the tooth gears to rotate. Gear rotation moves the trolley in the same direction of the rotation.

- To move the trolley to the left, face the chain wheel and pull on the right side of the chain.
- To move the trolley to the right, face the chain wheel and pull on the left side of the chain.

RECORD OF SATISFACTORY CONDITION

After receiving the unit and before using it for the first time, create a record that describes its appearance and operation. Thoroughly photograph the unit from multiple angles. Take close range photographs of the labels, data plates, and tags, drive wheels, the equalizer pin, the left and right ear cases, the chain (model E-MT-C), and fasteners. Move the trolley several feet in each direction along the beam flange. Record your observations about how the unit looks and sounds as it moves. Make note of the effort required to move the trolley. Collect all notes and photos in a file. The file is a record of the trolley in satisfactory condition. Compare the results of all inspections to this Record to determine whether a component is in satisfactory condition or requires repair or replacement. If issues are discovered during an inspection, DO NOT use the trolley until it is restored to satisfactory condition. Cosmetic changes, like damaged surface coating (paint or powdercoat) are not changes from satisfactory condition. However, touchup paint should be applied wherever the finish is damaged as soon as damage occurs.

LOAD TESTS

After creating a [RECORD OF SATISFACTORY CONDITION](#) and before using the trolley for the first time, a qualified person should conduct a load test. The test load should be 125% of the capacity/rated load. For example, if the capacity is 1,000 lb. (454.5kg), then the test load should be 1,250 pounds (568.2kg). Attach the unit to an appropriately rated overhead lifter. Raise the unit until it is suspended. Leave the unit suspended for a few minutes. Return it to the ground and unload it. Perform a *Frequent Inspection* and a *Periodic Inspection* as described in [INSPECTIONS & MAINTENANCE](#) (below) to confirm that the trolley remains in satisfactory condition. The trolley must undergo load testing before being returned to service any time it is repaired.

INSPECTIONS & MAINTENANCE

Inspections and repairs should only be performed by qualified persons. Compare the results of each inspection to the [RECORD OF SATISFACTORY CONDITION](#) (the "RECORD"). Do not use the trolley unless all parts are in satisfactory condition. Replace parts that are not in satisfactory condition before returning the trolley to service. **DON'T GUESS! If you have any questions about the condition of your hopper, speak with TECHNICAL SERVICE personnel.** The phone number is provided on the cover page of this manual. **Never make temporary repairs of damaged or missing parts.** Only use approved replacement parts.

Frequent Inspection

At least once per week, inspect all functional operating mechanisms.

i. Assess Operation:

1. Move the trolley along the beam flange and evaluate its operation. The trolley should roll smoothly along the flange.
2. Check both side plates of the trolley for evidence of spreading, bending, warping, and cracking. Clearance between *each drive wheel or tooth gear* and the beam flange should be no more than 1/8in. to 1/16in. (1/8-1/4 inch overall). See [INSTALLING THE TROLLEY](#) diagram, "Maximum permissible gap", on p. 4.

- ii. Drive wheels (EM-T) or tooth gears (EM-T-C), drive spindle, equalizer pin, and chain wheel (EM-T-C): Visually inspect each component for cracks, warps, significant wear, and other forms of damage or deterioration. Confirm that all are in satisfactory condition.

Periodic Inspection

At least once every 6 months, perform the following inspections:

- a. Perform a "Frequent Inspection".
- b. Fasteners: Check bolts, nuts, washers, etc. Make sure that connections are tight.
- c. Evidence of wear, corrosion, cracks, or deformations of operational components: Examine left and right gear cases, drive wheels, tooth gears and drive spindle (-C models), equalizer pin, chain (-C models), and bearings.
- d. Labels: Labels, plates, and tags must be easily readable and affixed or otherwise attached to the trolley as shown in the [LABELING DIAGRAM](#) on p. 6. **NOTE:** Label appearance and content is subject to change over time, and consequently, replacement labels might differ from labels shown in the manual supplied with the unit.

(Inspections Instructions Continue on Following Page)

To maximize the service life of the trolley, routinely clean and lubricate it.

- 1) Cleaning: Clean the following components with an acid-free solvent at least once per year. Heavy usage requires more frequent cleaning.
 - a. Chain
 - b. Drive Wheels or Gear Teeth
 - c. Equalizer Pin
 - e. Fasteners
- 2) Lubrication: [NOTE: Roller bearings of the trolley are sealed and require no lubrication.]
 - a. EM-T-C – Apply EP1 grease or the equivalent if the usage environment temperature is in the range from -20°F to 50°F. EP2 grease is appropriate for temperatures from 30°F to 120°F. Apply lubricant to the contact surfaces as frequently as necessary to ensure that all teeth are thoroughly covered.
 - b. Fasteners and pins – Lubricate fasteners and pins, especially threaded surfaces, with appropriate lubricants (e.g. anti-seize compound or thread lubricant).

LABELING DIAGRAM

Label content and location are subject to change so your product might not be labeled exactly as shown. Compare this diagram to your [RECORD OF SATISFACTORY CONDITION](#). Replace all labels that are damaged, missing, or not easily readable (e.g. faded). Order replacement labels by contacting the [TECHNICAL SERVICE AND REPLACEMENT PARTS DEPARTMENT](#) online at <http://www.vestil.com/page-parts-request.php>. Alternatively, you may request replacement parts and/or service by calling (260) 665-7586 and asking the operator to connect you to the [PARTS DEPARTMENT](#).



E-MT-##

Model	Label No.
E-MT-1	741
E-MT-2	742
E-MT-4	743
E-MT-6	744
E-MT-8	745
E-MT-10	746



E-MT-##-C

Model	Label No.
E-MT-1-C	747
E-MT-2-C	748
E-MT-4-C	749
E-MT-6-C	750
E-MT-8-C	751
E-MT-10-C	752

LIMITED WARRANTY

Vestil Manufacturing Company ("Vestil") warrants this product to be free of defects in material and workmanship during the warranty period. Our warranty obligation is to provide a replacement for a defective, original part covered by the warranty after we receive a proper request from the Warrantee (you) for warranty service.

Who may request service?

Only a warrantee may request service. You are a warrantee if you purchased the product from Vestil or from an authorized distributor AND Vestil has been fully paid.

Definition of "original part"?

An original part is a part used to make the product as shipped to the Warrantee.

What is a "proper request"?

A request for warranty service is proper if Vestil receives: 1) a photocopy of the Customer Invoice that displays the shipping date; AND 2) a written request for warranty service including your name and phone number. Send requests by one of the following methods:

US Mail
Vestil Manufacturing Company
2999 North Wayne Street, PO Box 507
Angola, IN 46703

Fax
(260) 665-1339
Phone
(260) 665-7586

Email
info@vestil.com
Enter "Warranty service request"
in subject field.

In the written request, list the parts believed to be defective and include the address where replacements should be delivered. After Vestil receives your request for warranty service, an authorized representative will contact you to determine whether your claim is covered by the warranty. Before providing warranty service, Vestil will require you to send the entire product, or just the defective part (or parts), to its facility in Angola, IN.

What is covered under the warranty?

The warranty covers defects in the following original, dynamic parts: motors, hydraulic pumps, motor controllers, and cylinders. It also covers defects in original parts that wear under normal usage conditions ("wearing parts"), such as bearings, hoses, wheels, seals, brushes, and batteries.

How long is the warranty period?

The warranty period for original dynamic components is 30 days. For wearing parts, the warranty period is 30 days. Both warranty periods begin on the date Vestil ships the product to the Warrantee. If the product was purchased from an authorized distributor, the periods begin when the distributor ships the product. Vestil may, at its sole discretion, extend a warranty period for products shipped from authorized distributors by up to 30 days to account for shipping time.

If a defective part is covered by the warranty, what will Vestil do to correct the problem?

Vestil will provide an appropriate replacement for any covered part. An authorized representative of Vestil will contact you to discuss your claim.

What is not covered by the warranty?

The Warrantee (you) is responsible for paying labor costs and freight costs to return the product to Vestil for warranty service.

Events that automatically void this Limited Warranty.

- Misuse;
- Negligent assembly, installation, operation or repair;
- Installation/use in corrosive environments;
- Inadequate or improper maintenance;
- Damage sustained during shipping;
- Collisions or other accidents that damage the product;
- Unauthorized modifications: Do not modify the product IN ANY WAY without first receiving written authorization from Vestil.

Do any other warranties apply to the product?

Vestil Manufacturing Co. makes no other express warranties. All implied warranties are disclaimed to the extent allowed by law. Any implied warranty not disclaimed is limited in scope to the terms of this Limited Warranty. Vestil makes no warranty or representation that this product complies with any state or local design, performance, or safety code or standard. Noncompliance with any such code or standard is not a defect in material or workmanship.

