

# **INSTALLATION**

## *Product Manual*

Version: 020500US-01-24A-AA

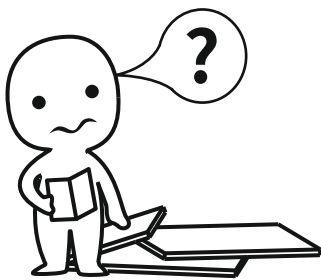

### **IMPORTANT INFORMATION!**

please read the entire manual before starting to assemble and/or using this product. follow the manual thoroughly and keep it for further reference.

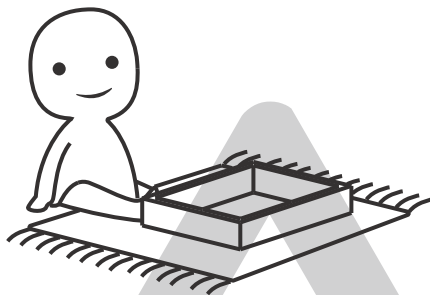

### **AVOID SCRATCHES!**

In order to avoid scratching this furniture should be assembled on a soft layer- could be a rug.

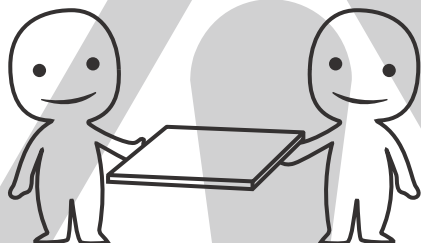

### **IMPROVE EFFICIENCY !**

Try to find a partner to install with you, which can speed up the installation efficiency and shorten the time.

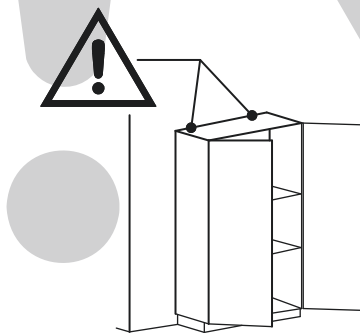
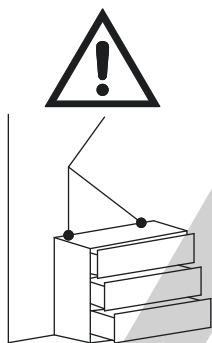

### **ANTI-TOPPLE WARNING !**

Overturnd furniture can cause serious or fatal crush injuries. To prevent tipping over, be sure to use the wall attachment, if not included with this product. Please purchase the wall attachment that fit your wall. If unsure, seek professional advice. Please read and follow each step of the instructions carefully.

### **IMPORTANT !**

It is important that any product which is assembled using any kind of screw is re-tightened 2 weeks after assembly, and once every 3 months - in order to assure stability through-out the lifespan of the product.

For regular maintenance and cleaning of the product, for the frame, please use a rag dipped in neutral detergent to fully wipe it, and then dry it with a clean rag. For glass materials, wipe with a rag dampened with water glass cleaner, and then dry with a dry rag.

Do not use an electric screwdriver, and do not use too much force when installing, because the board is easy to break.

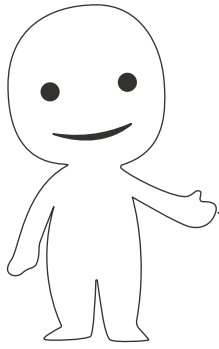

Please prepare the following tools

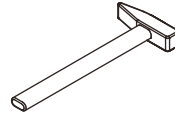
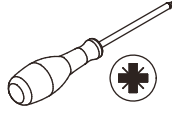
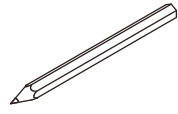

When installing, please carefully confirm whether each screw corresponds to the manual, accessories with similar shapes can be distinguished by size

A x 78

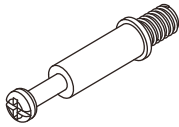

Ø 6 x 35 mm

B x 78



Ø 15 x 10 mm

C x 31

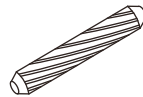

Ø 6 x 30 mm

E x 24

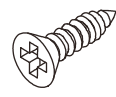

Ø 3.5 x 12 mm

F x 26

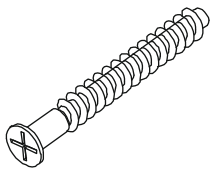

Ø 5 x 40 mm

G x 34

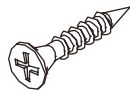

Ø 3.5 x 14 mm

H x 5

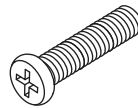

Ø 6 x 30 mm

I x 4



Ø 6 x 12 mm

J x 2

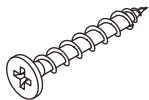

Ø 3.5 x 30 mm

L x 1

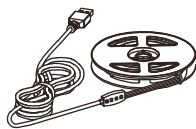

M x 10



Ø 4 x 18 mm

N x 5

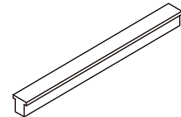

O x 4



P x 20



Q x 8



R x 4

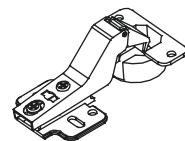

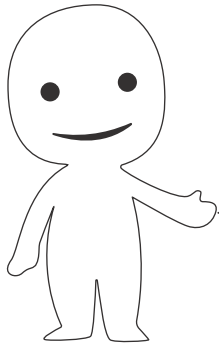

Please prepare the following tools

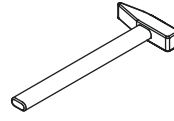
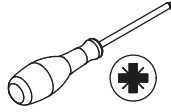
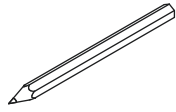

When installing, please carefully confirm whether each screw corresponds to the manual, accessories with similar shapes can be distinguished by size

S x 3

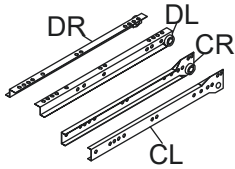

T x 24



Ø 4 x 8 mm

U x 10

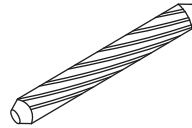

Ø 6 x 50 mm

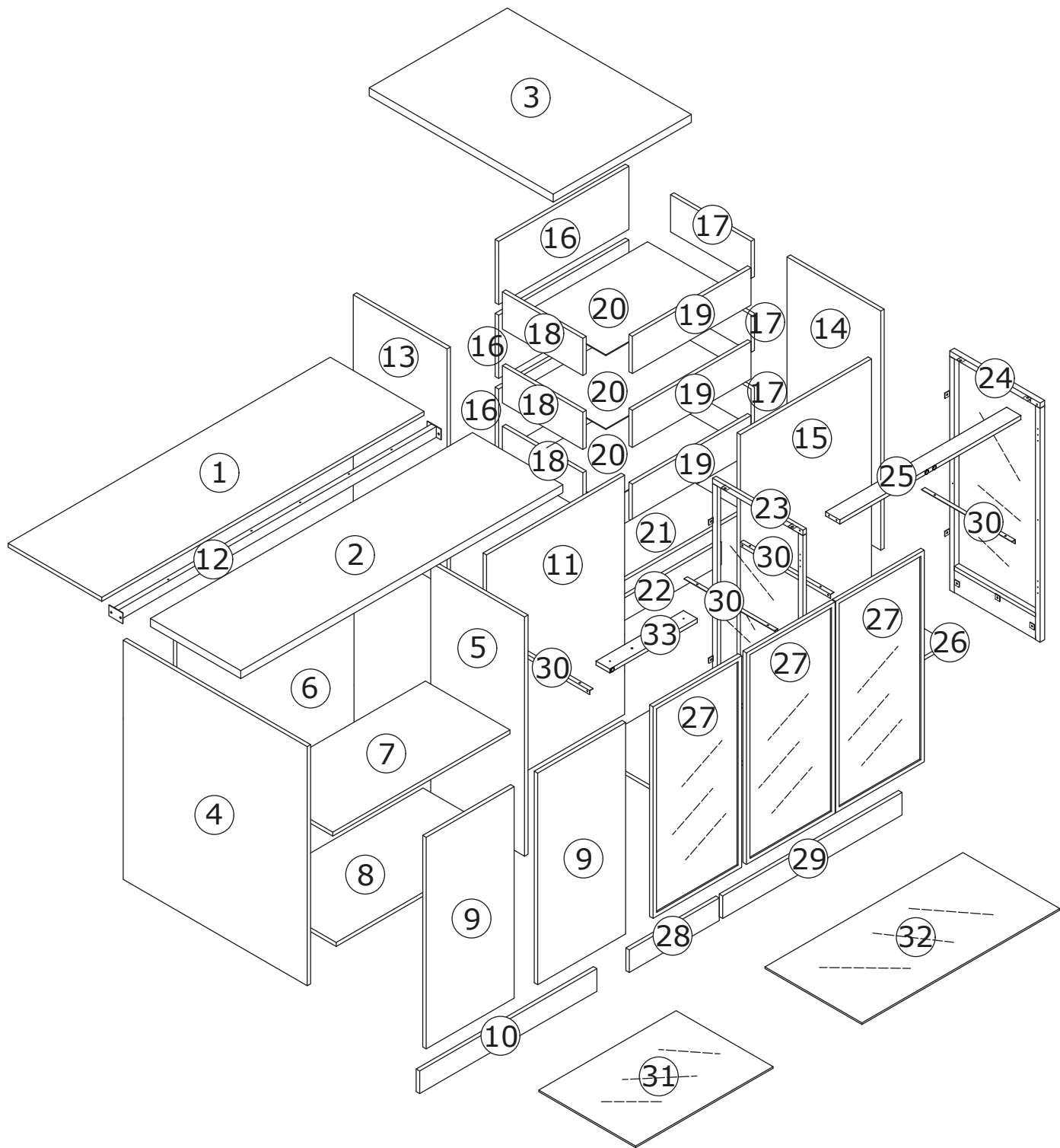

## ⚠ WARNING



**Children have died from furniture tipover. To reduce the risk of furniture tipover:**

- ALWAYS install Anti-tip device provided.
- NEVER put a TV on this product.
- NEVER allow children to stand, climb or hang on drawers, doors, or shelves.
- NEVER open more than one drawer at a time.
- Place heaviest items in the lowest drawers.



*This is a permanent label.  
Do not remove!*

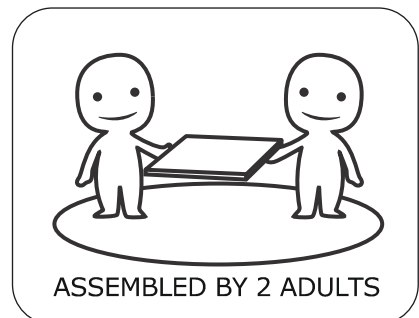

1

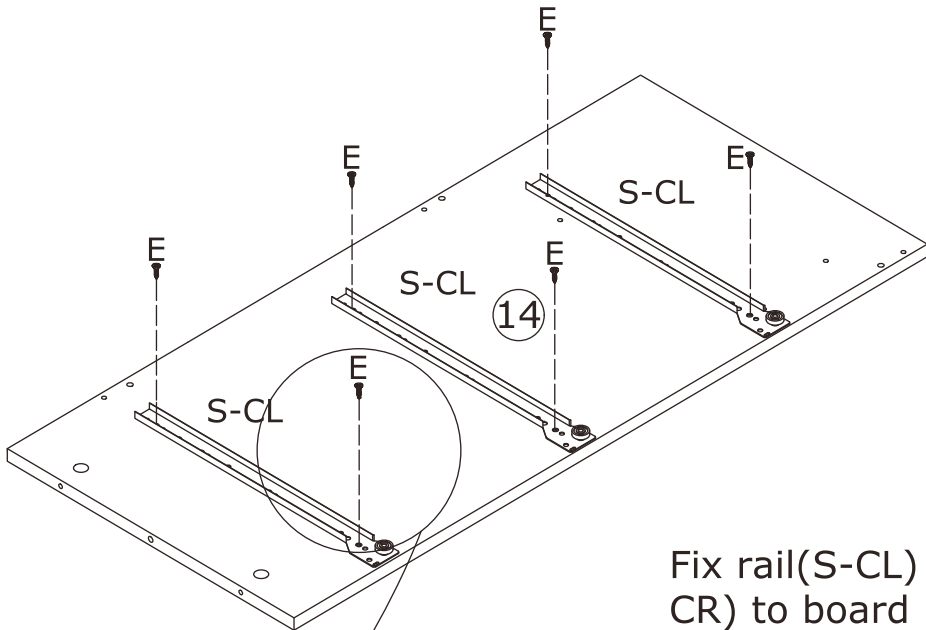
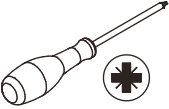
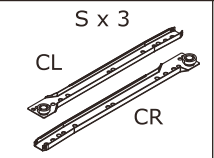
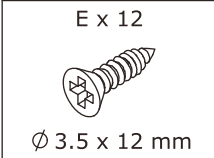

Fix rail(S-CL) and (S-CR) to board 14 and 13 with screw(E) as shown.

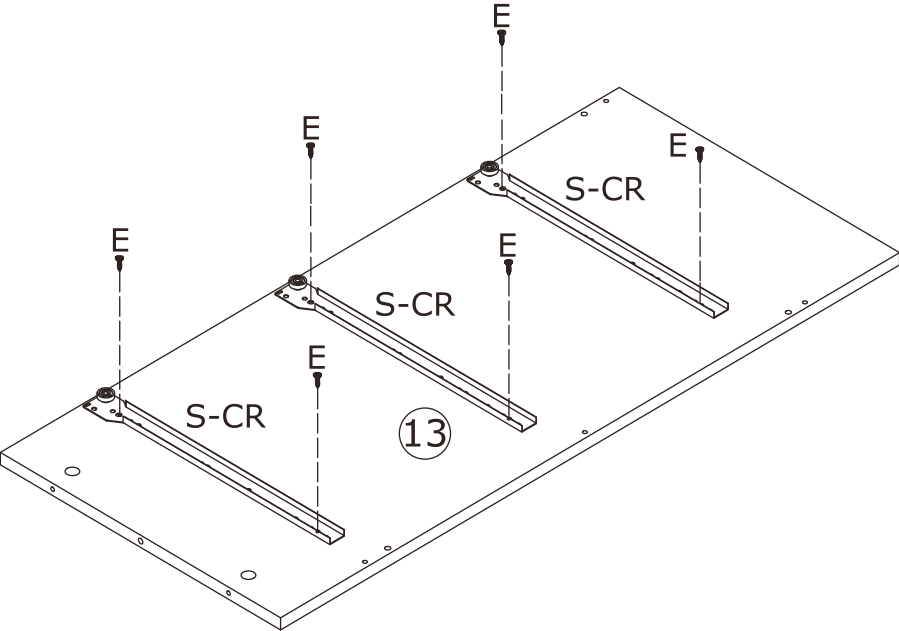
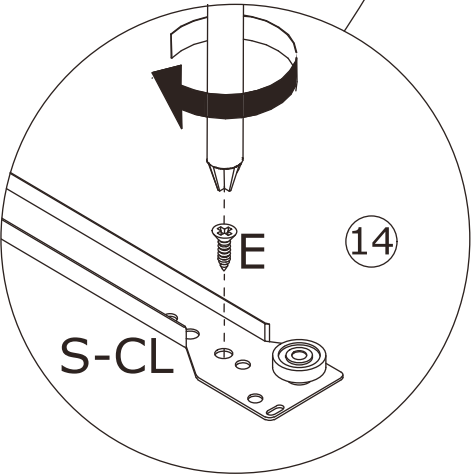

2

A x 16  
Ø6 x 35 mm

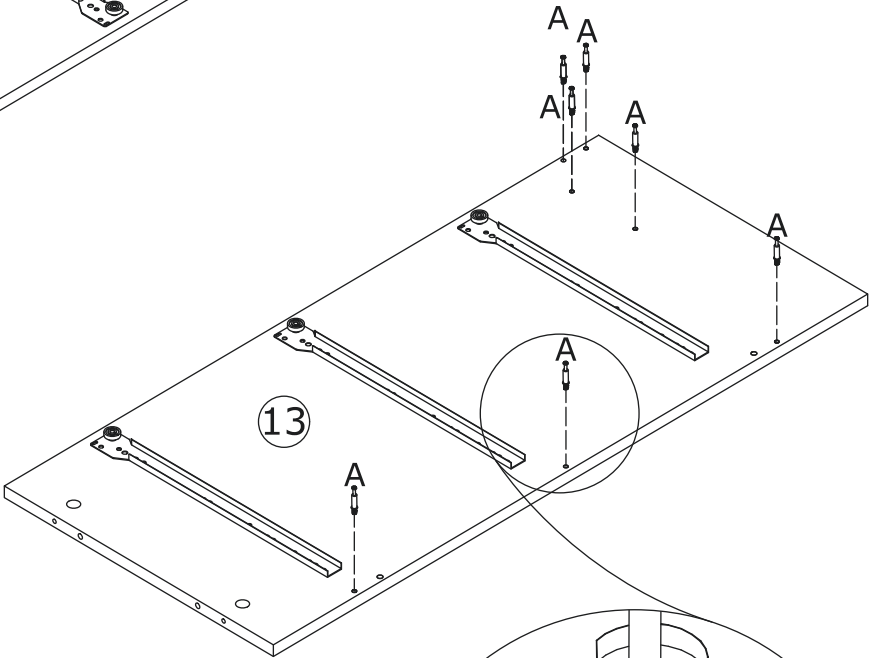
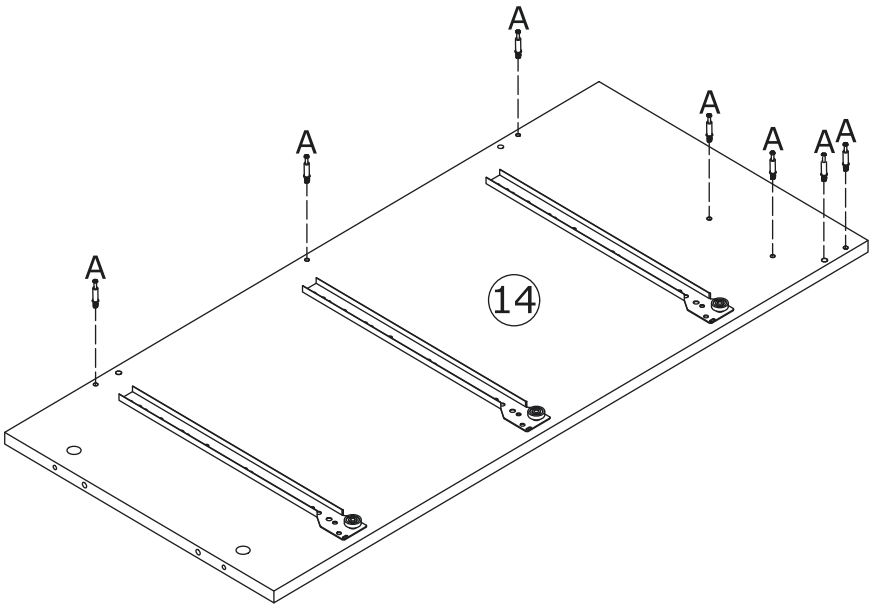
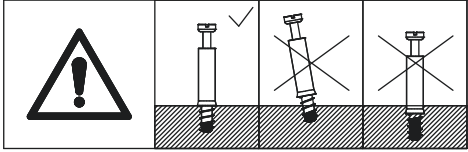
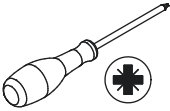

Screw eccentric rod(A) into board 13, 14 and 21 as shown.

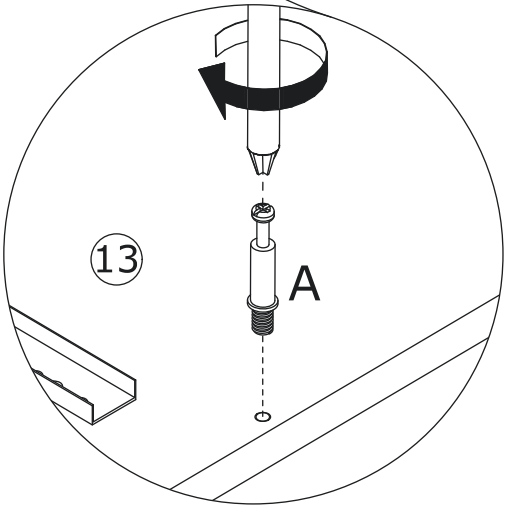
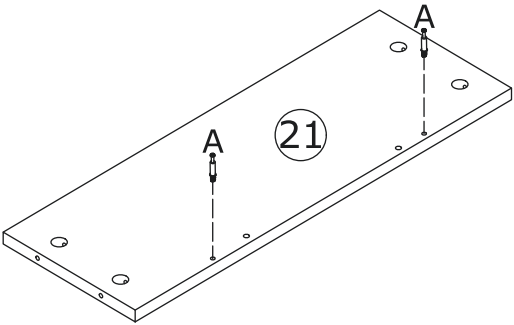

3

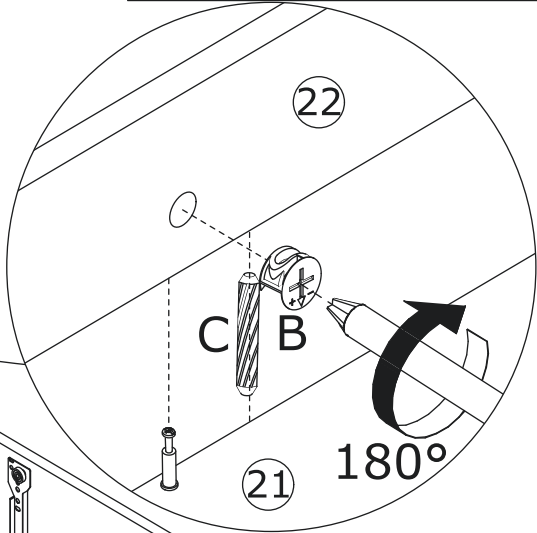
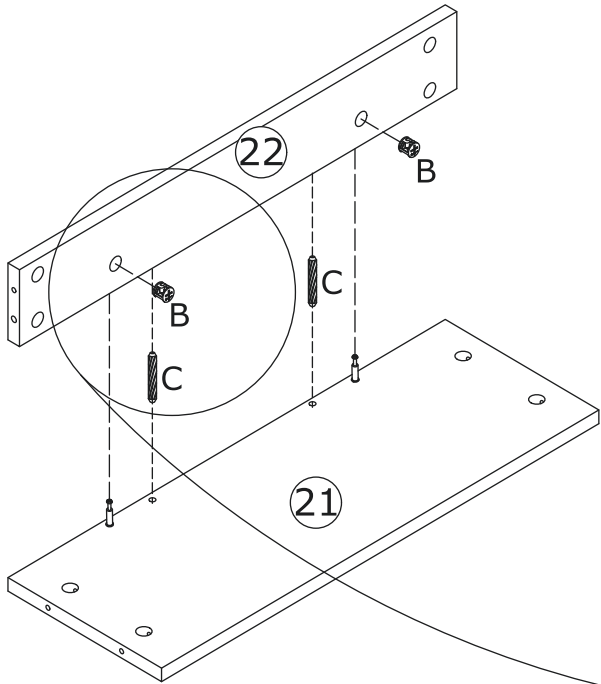
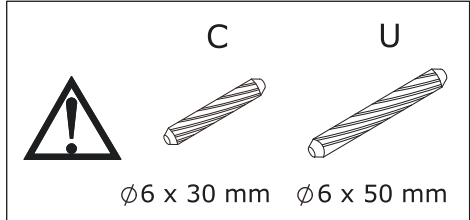
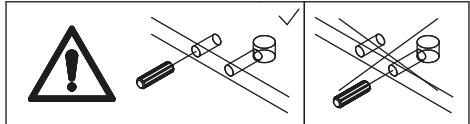
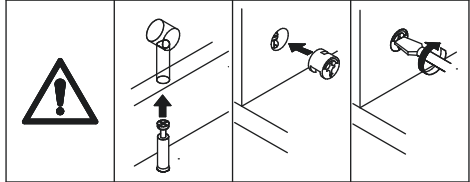
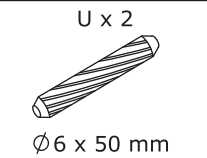
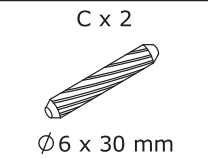
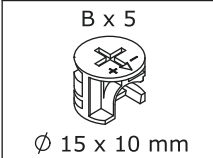

Attach board 22 to board 21 and board 13 to board 15 using **SHORT** wooden dowel(C) and **LONG** wooden dowel(U), add cam lock(B) into board 22,15 and turn clockwise to tighten as shown.

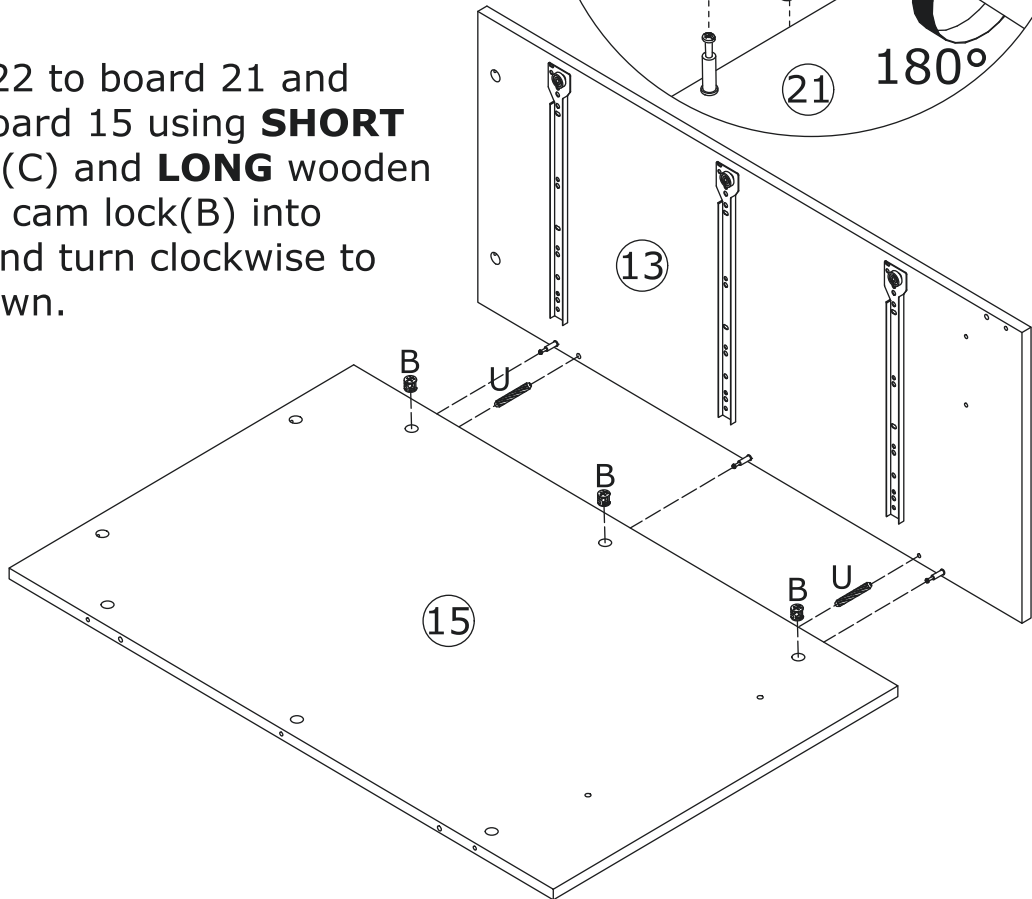

4

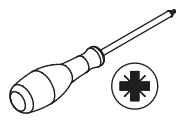
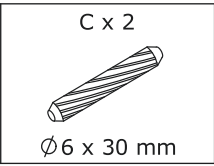
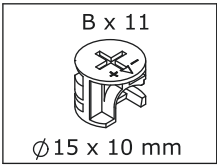

Attach board 21 and 22 to board 13 to board 15, add cam lock(B) into board 21,22 and turn clockwise to tighten as shown.

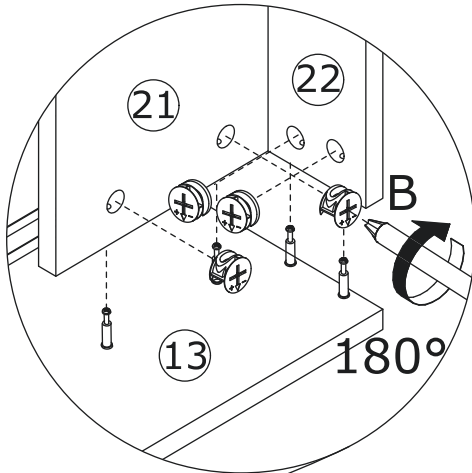
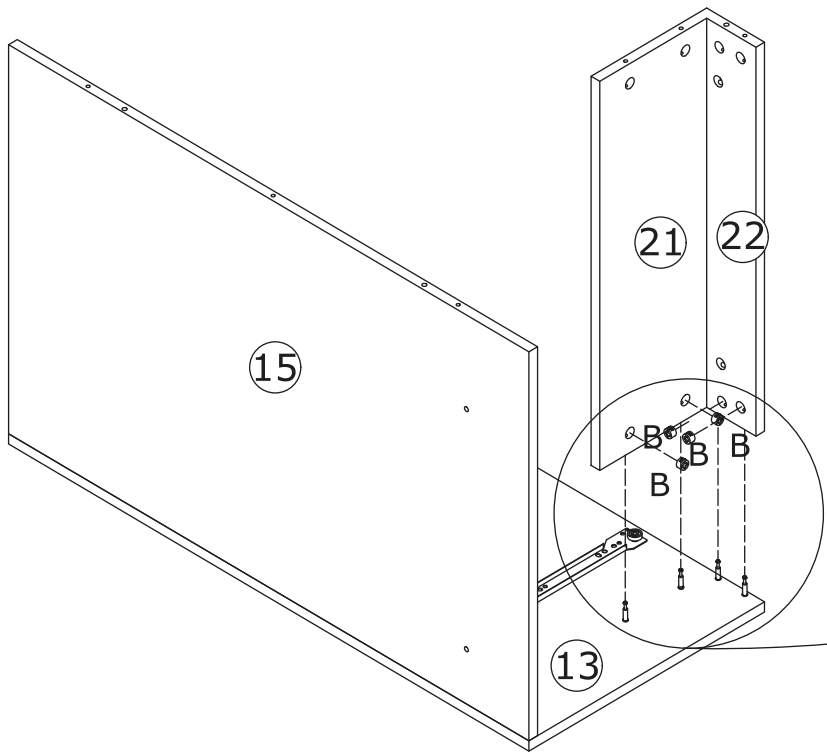
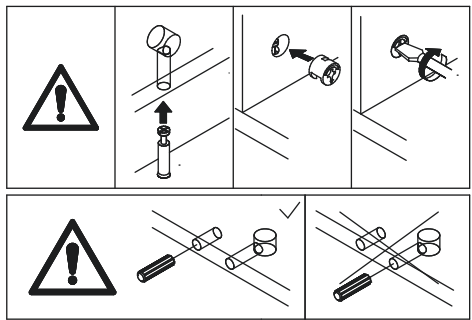

Attach board 14 to board 15, 21 and 22 using wooden dowel(C), add cam lock(B) into board 15,21,22 and turn clockwise to tighten as shown.

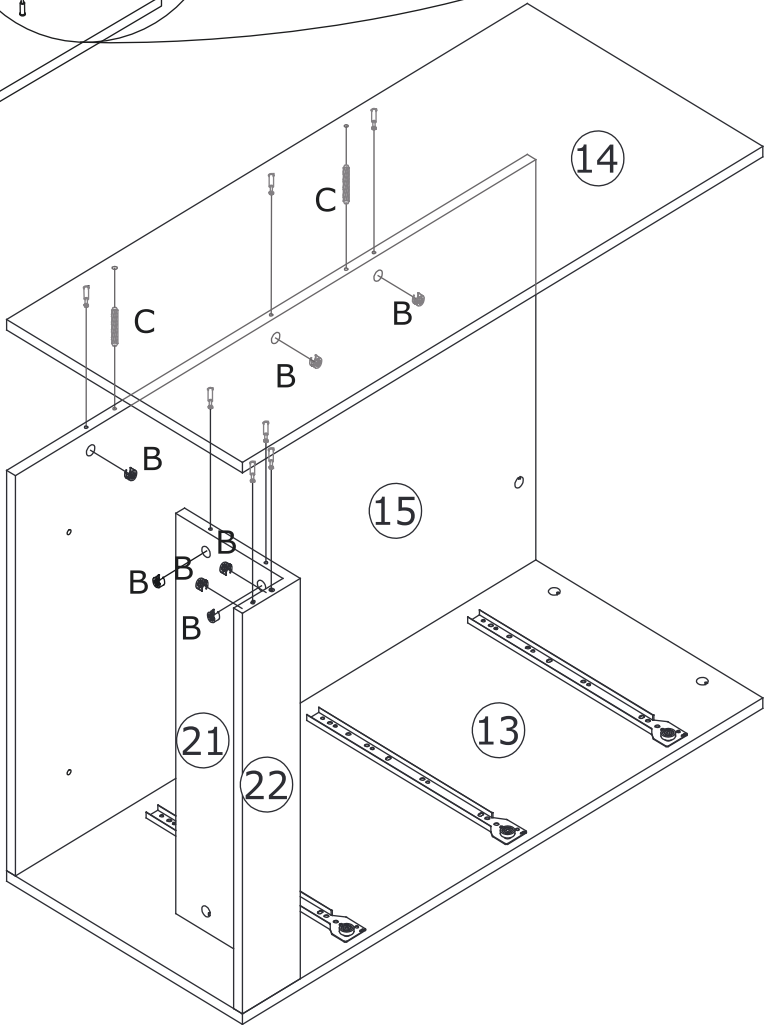

5

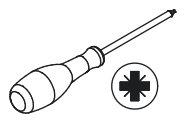
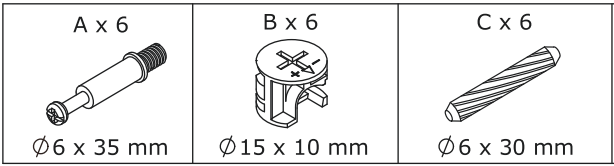

Screw eccentric rod(A)  
into board 3 as shown.

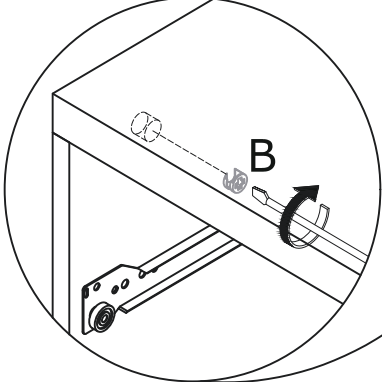
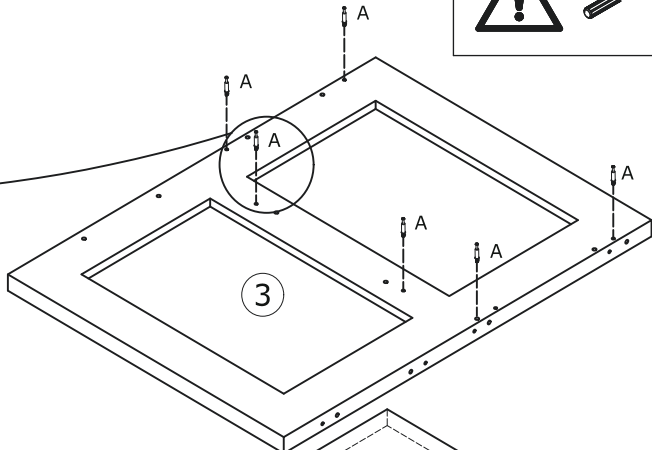
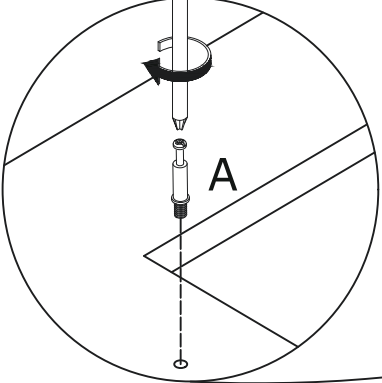
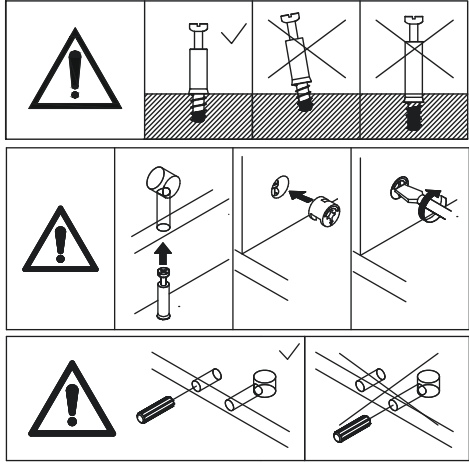

Attach board 3 to board  
13, 14 and 15 using  
wooden  
dowel(C), add cam lock  
(B) into  
board 13,14,15 and turn  
clockwise to tighten as  
shown.

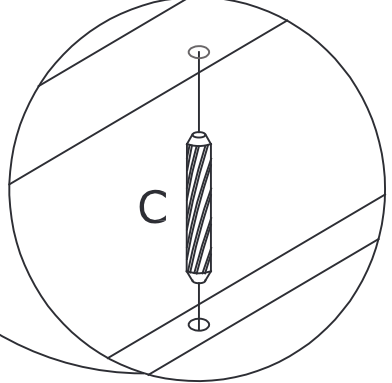
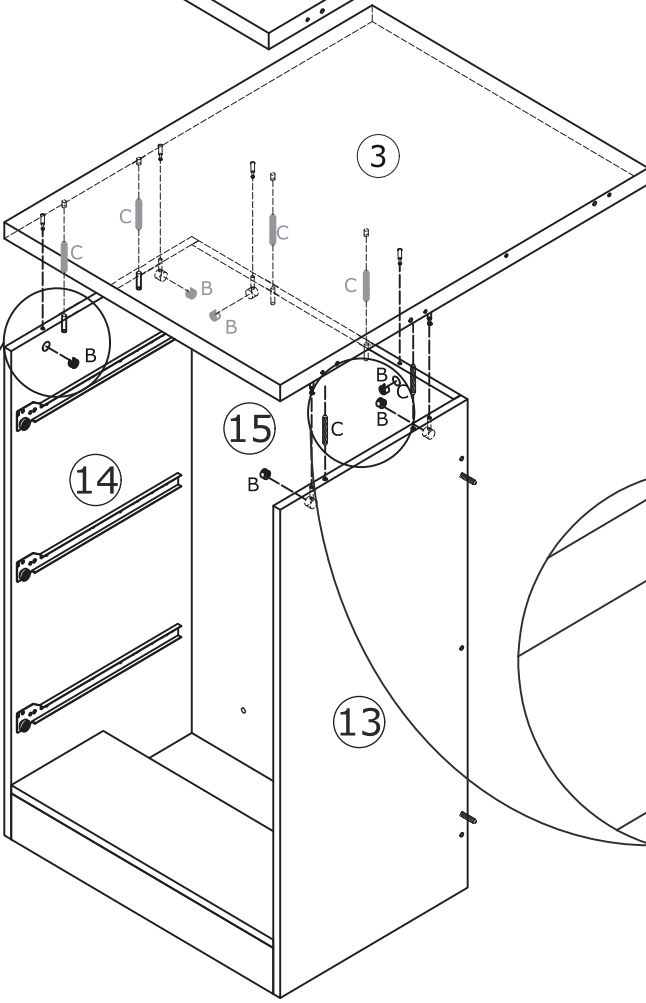

6

A x 4  
Ø6 x 35 mm

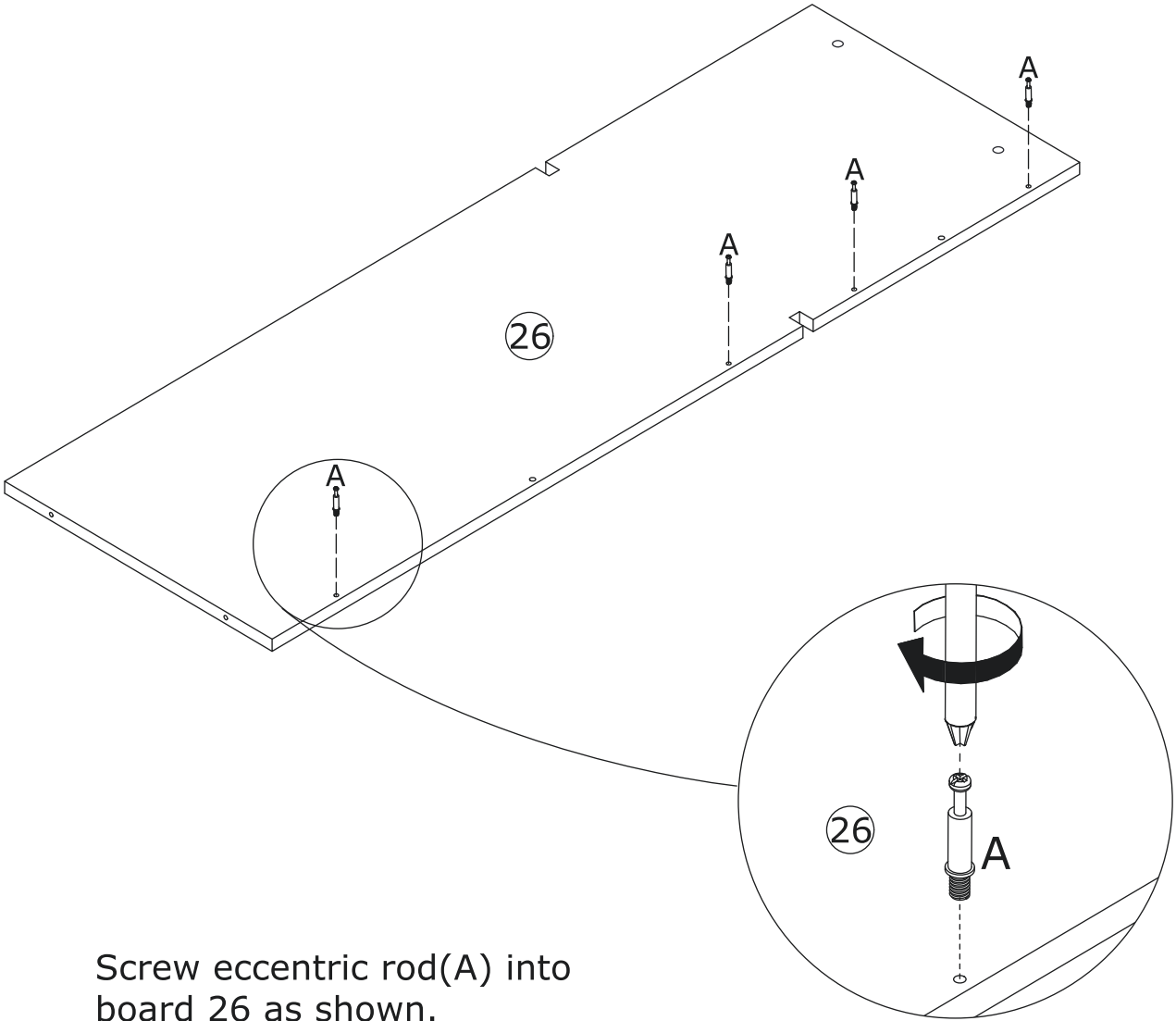
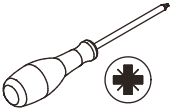

Screw eccentric rod(A) into board 26 as shown.

7

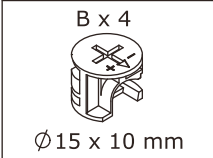

Attach board 10 to board 8 using wooden dowel(C) as shown.

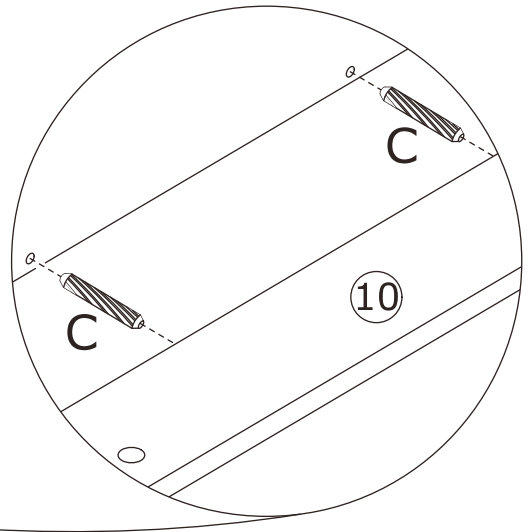
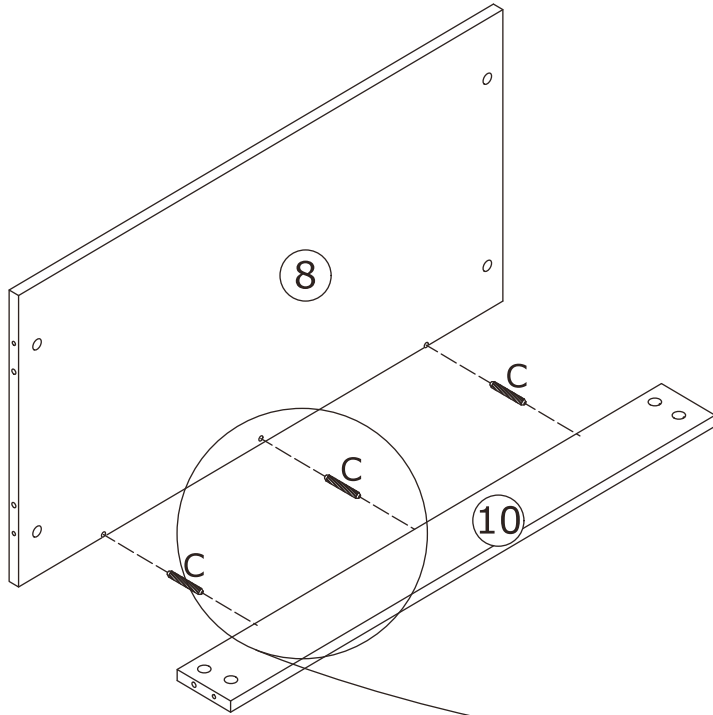
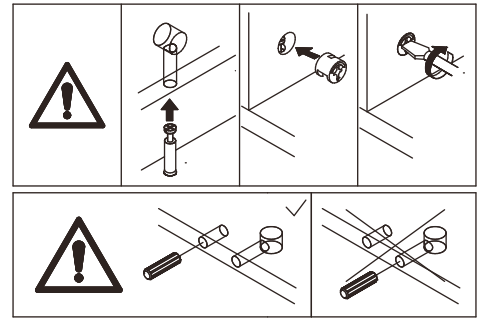

Attach board 26 to board 28 and 29 using wooden dowel(C), add cam lock(B) into board 28,29 and turn clockwise to tighten as shown.

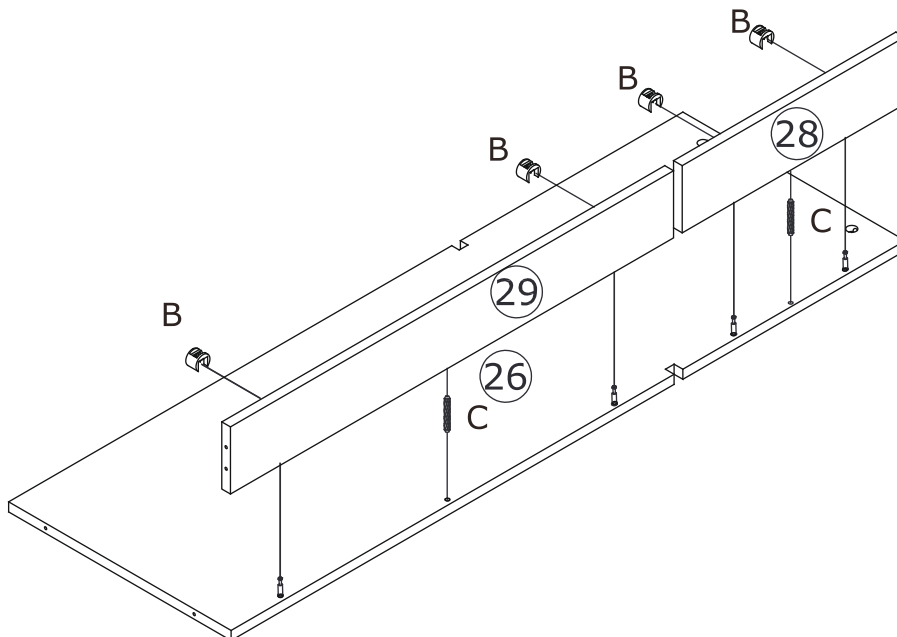

8

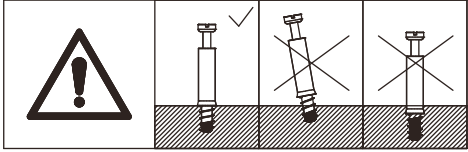
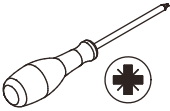

Screw eccentric rod(A)  
into board 5 as shown.

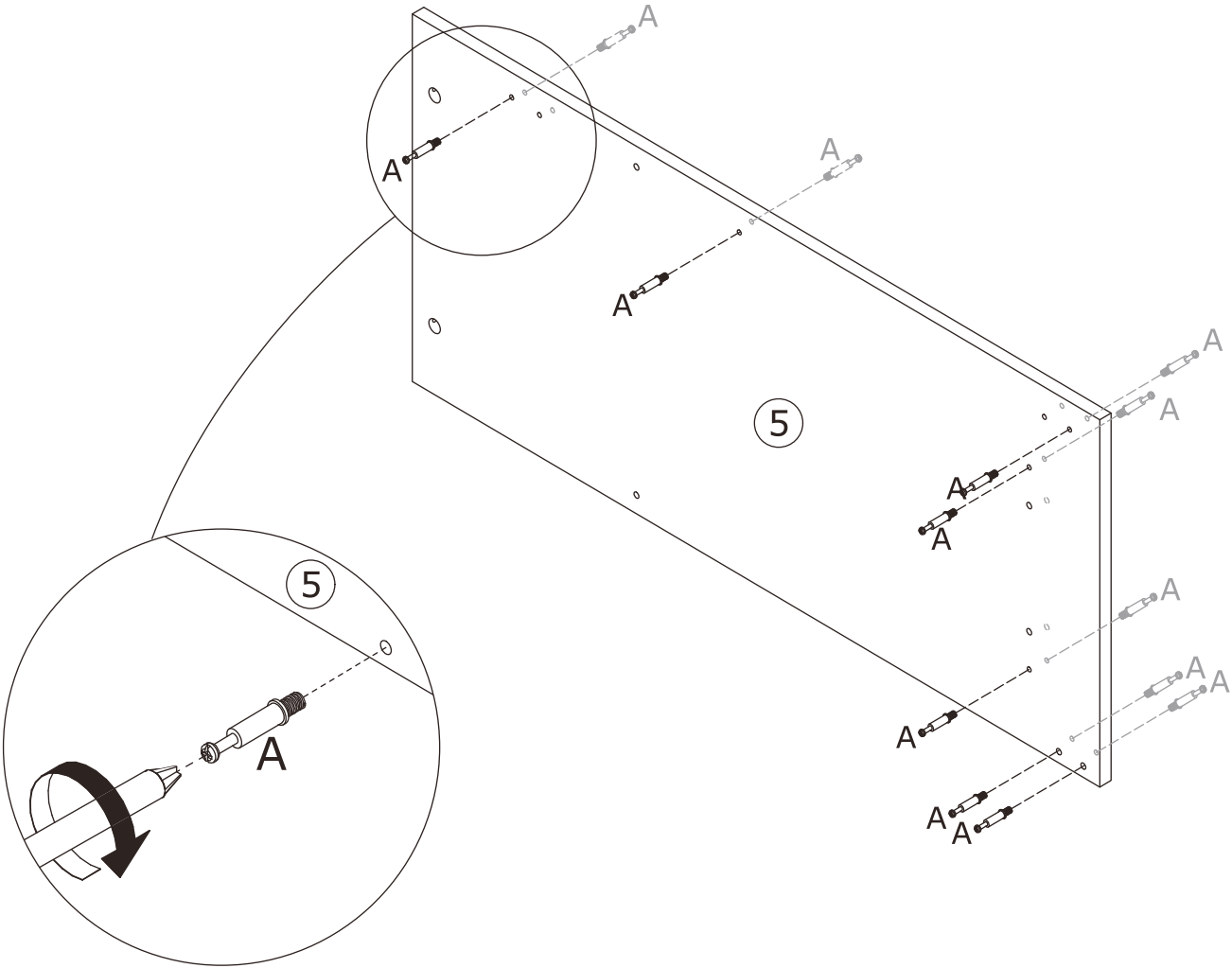

9

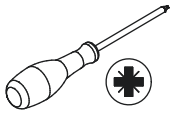
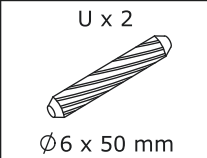
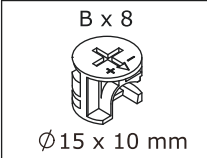

Attach board 5 to board 8 and 10 using wooden dowel(U), add cam lock(B) into and turn clockwise to tighten as shown.

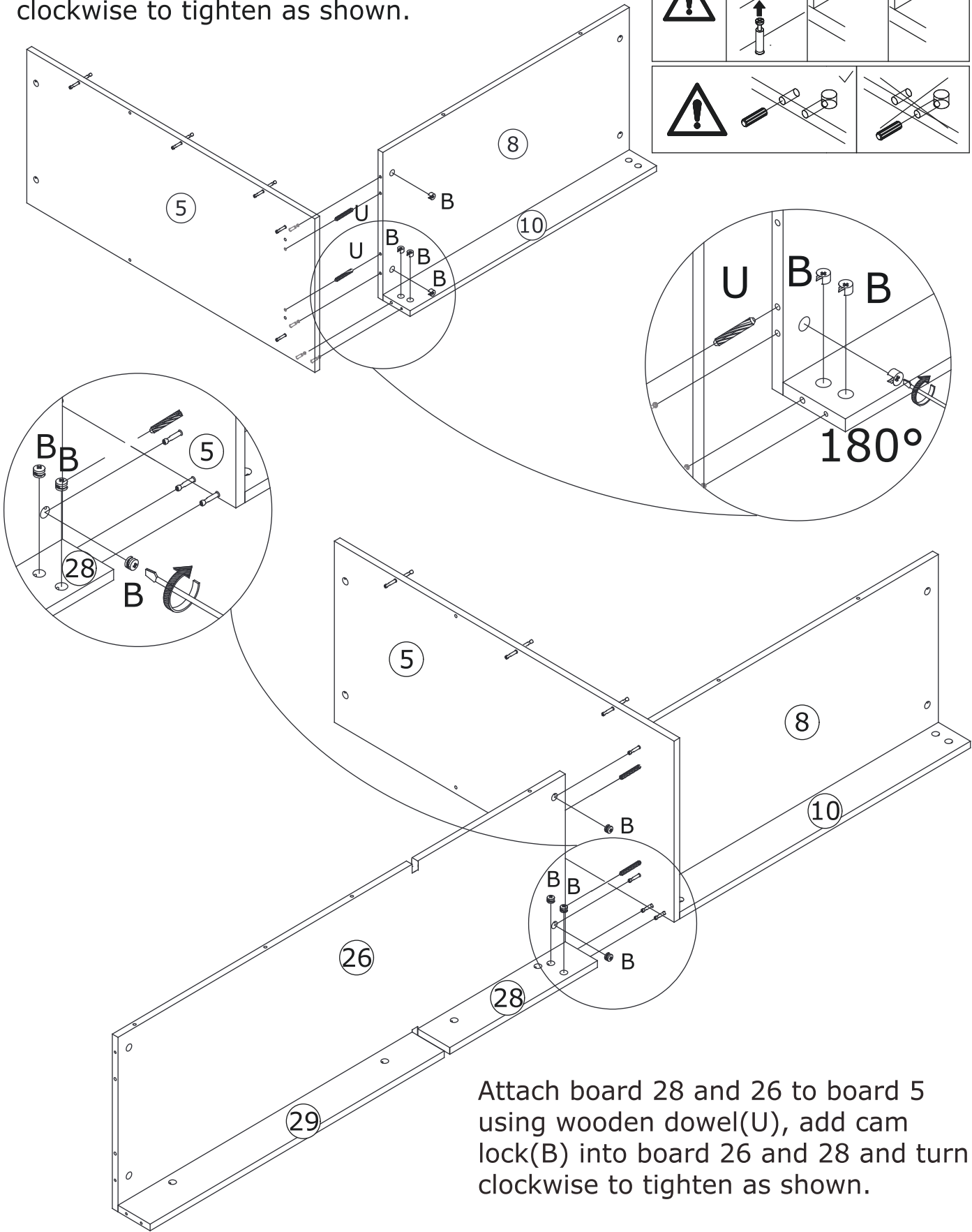
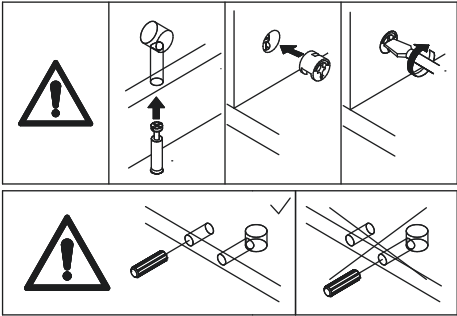

Attach board 28 and 26 to board 5 using wooden dowel(U), add cam lock(B) into board 26 and 28 and turn clockwise to tighten as shown.

10

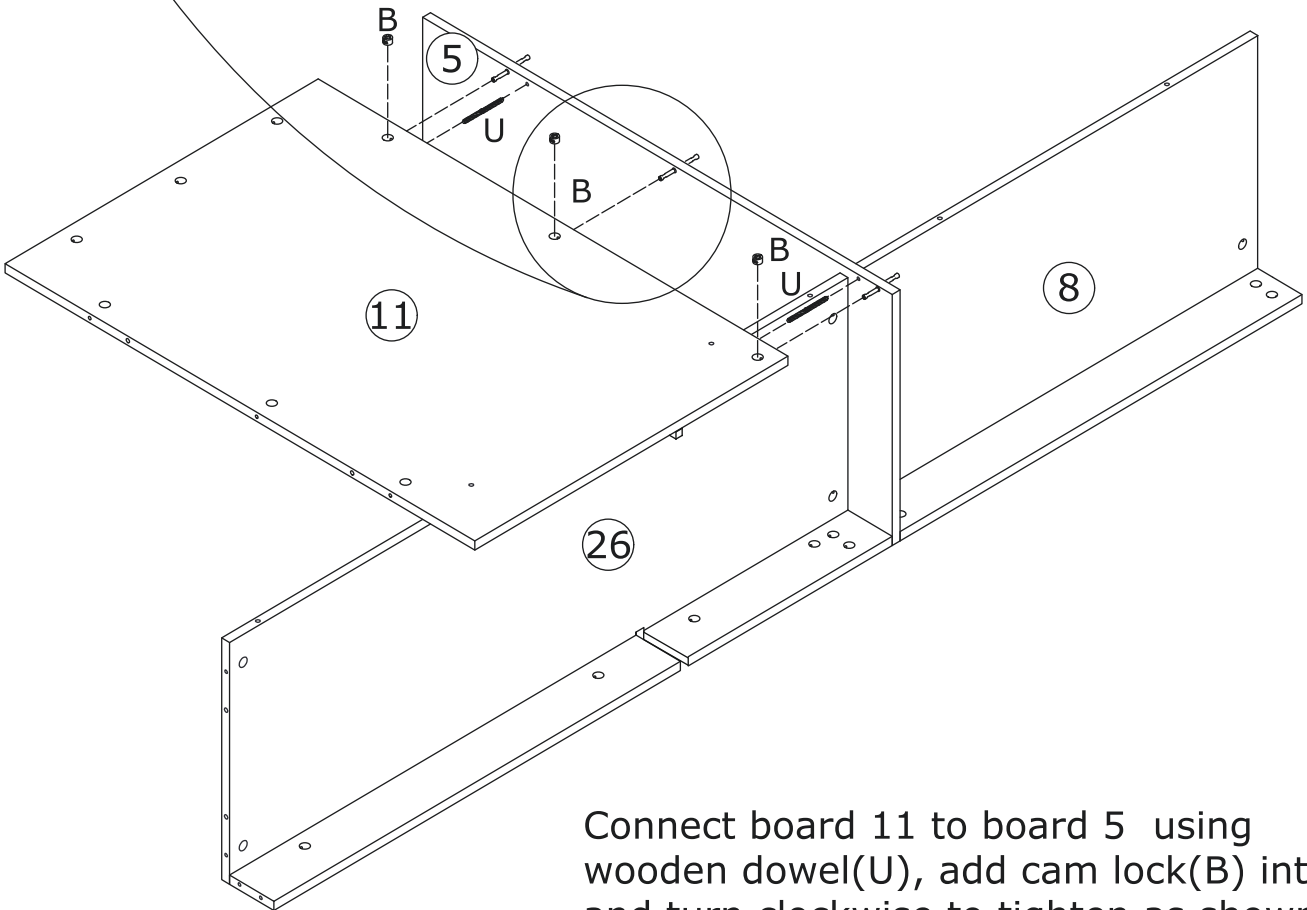
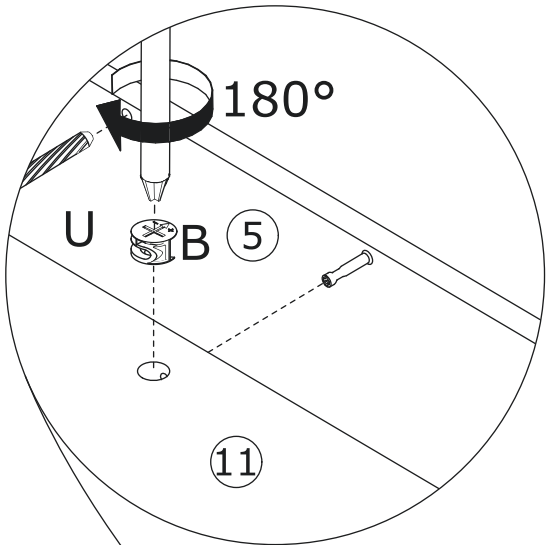
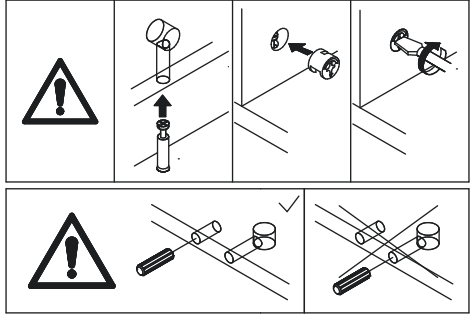
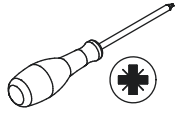
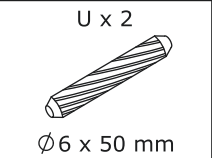
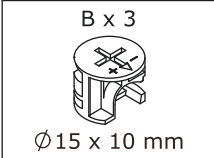

Connect board 11 to board 5 using wooden dowel(U), add cam lock(B) into and turn clockwise to tighten as shown.

11

B x 3  
Ø 15 x 10 mm

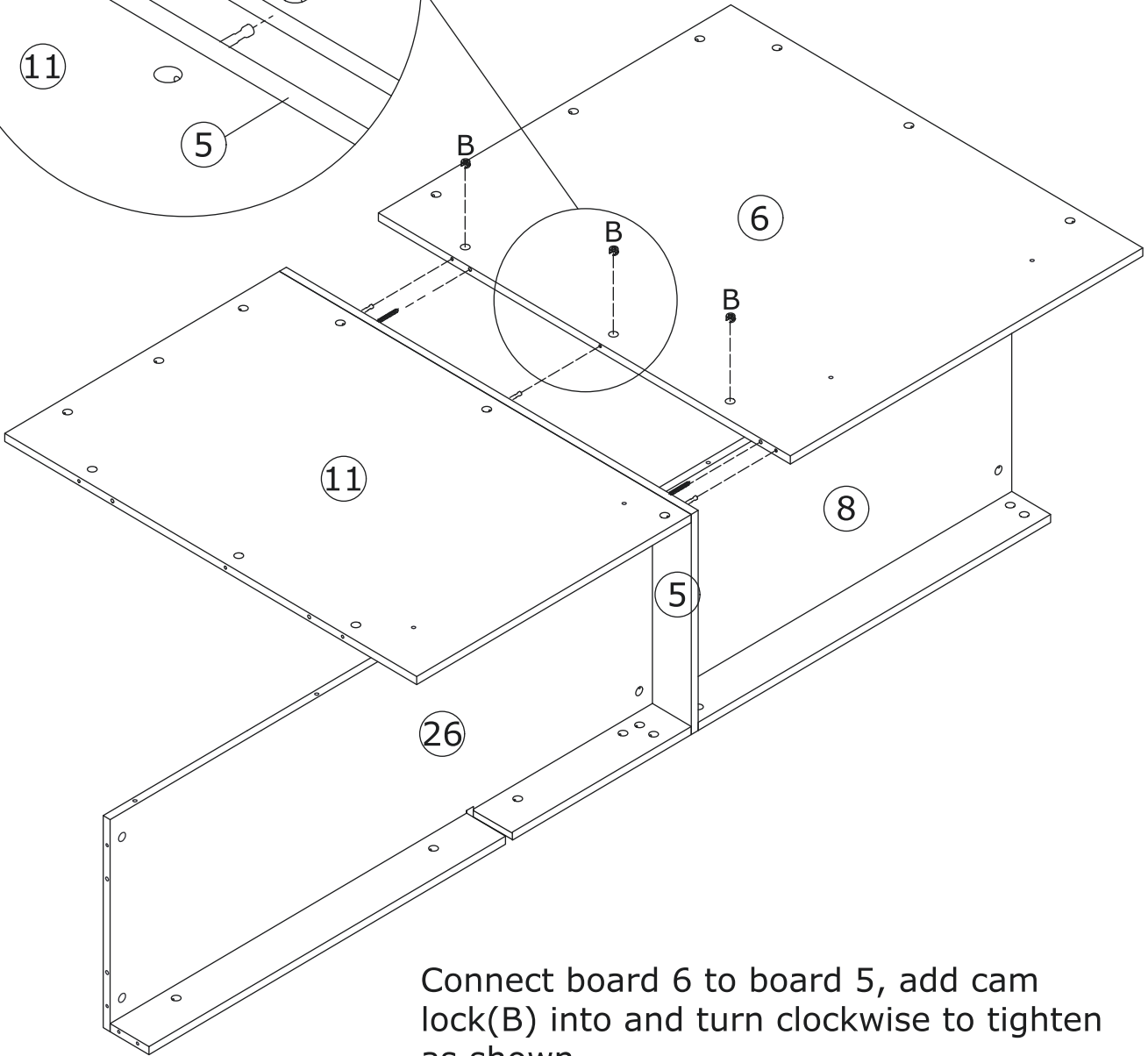
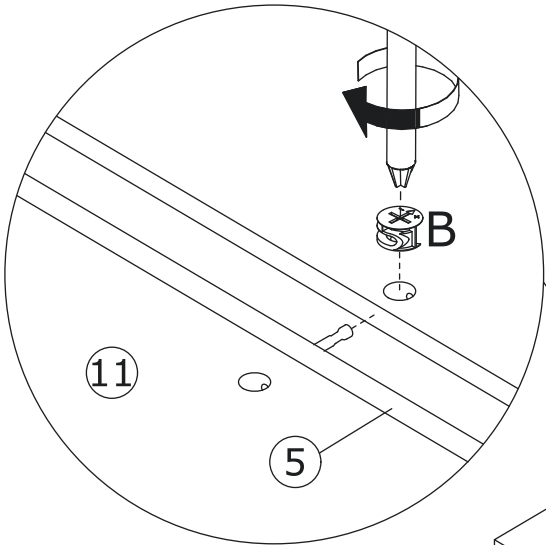
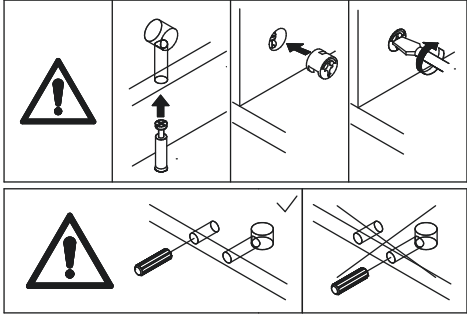
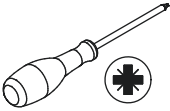

Connect board 6 to board 5, add cam lock(B) into and turn clockwise to tighten as shown.

12

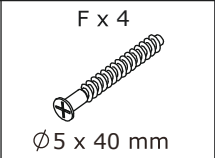

Fix board 6 and 11 to board 8 and 26 with screw(F) as shown.

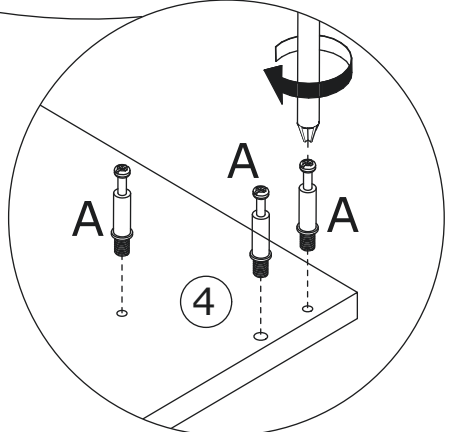
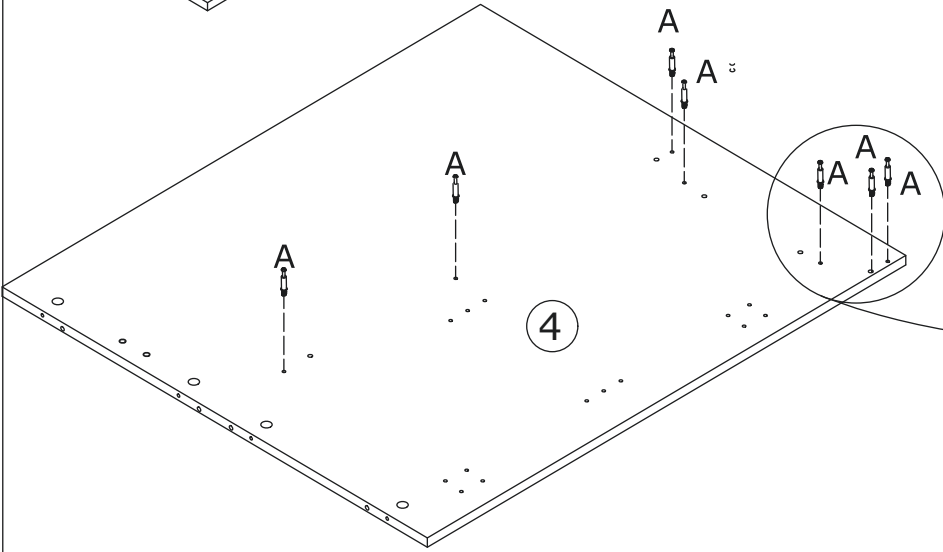
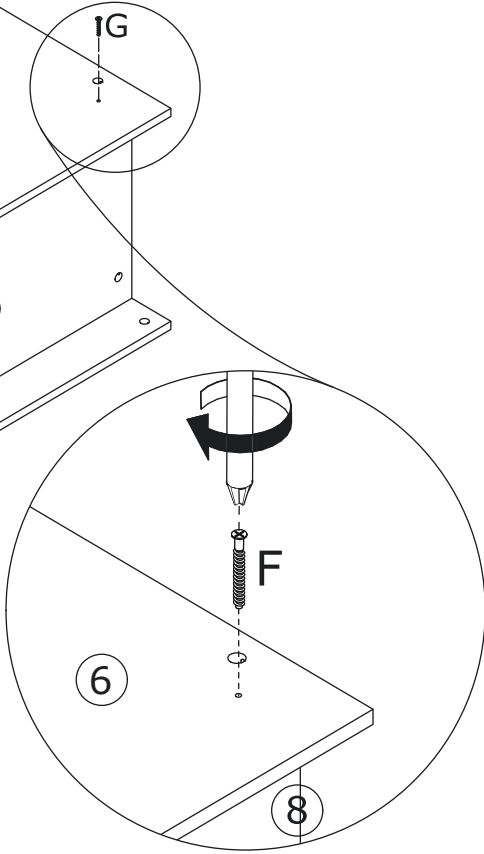
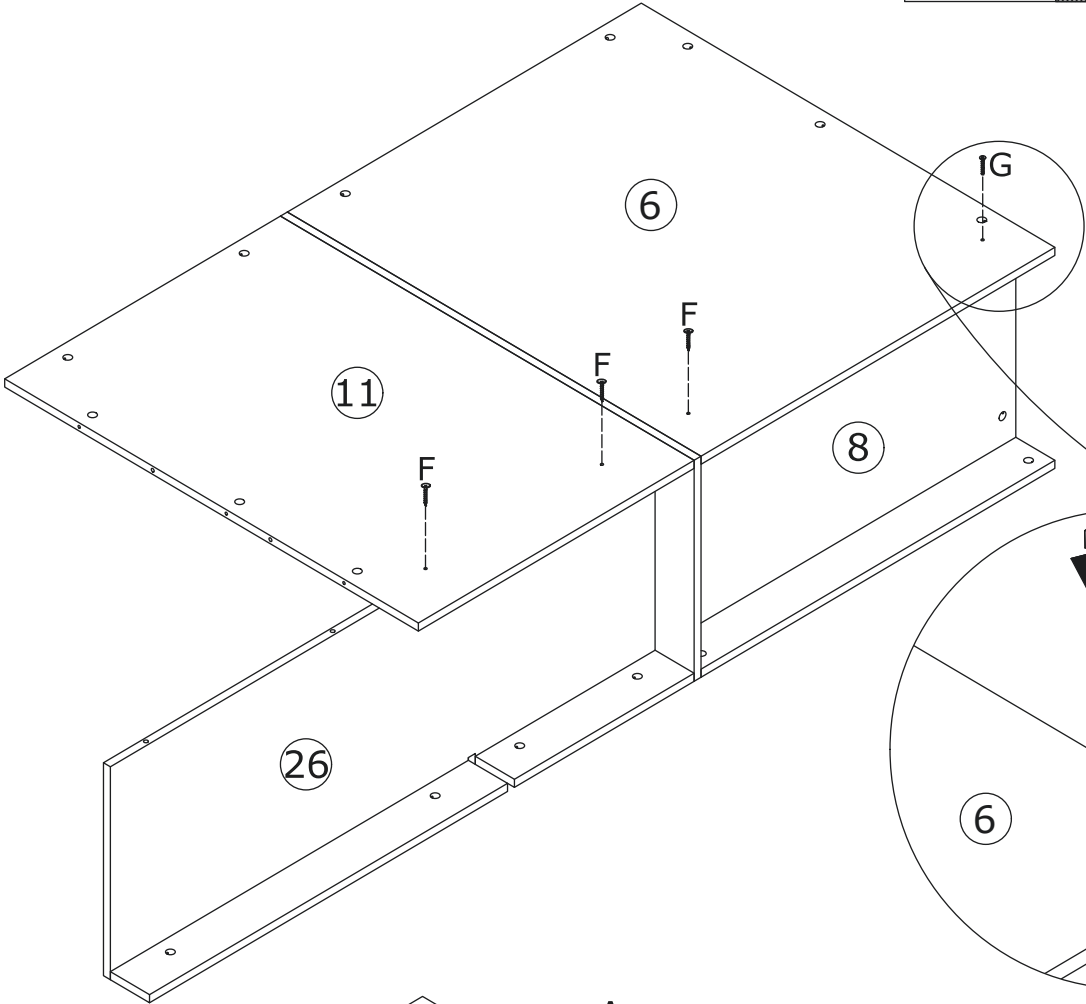
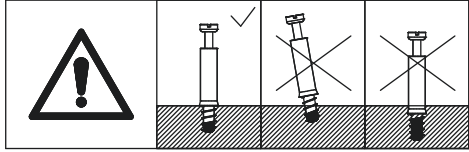

Screw eccentric rod(A) into board 4 at first.

# 13

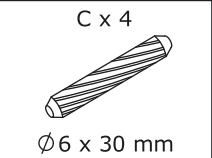
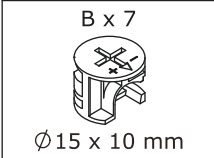

Attach board 4 to board 6, 8 and 10 using wooden dowel(C), add cam lock(B) into and turn clockwise to tighten as shown.

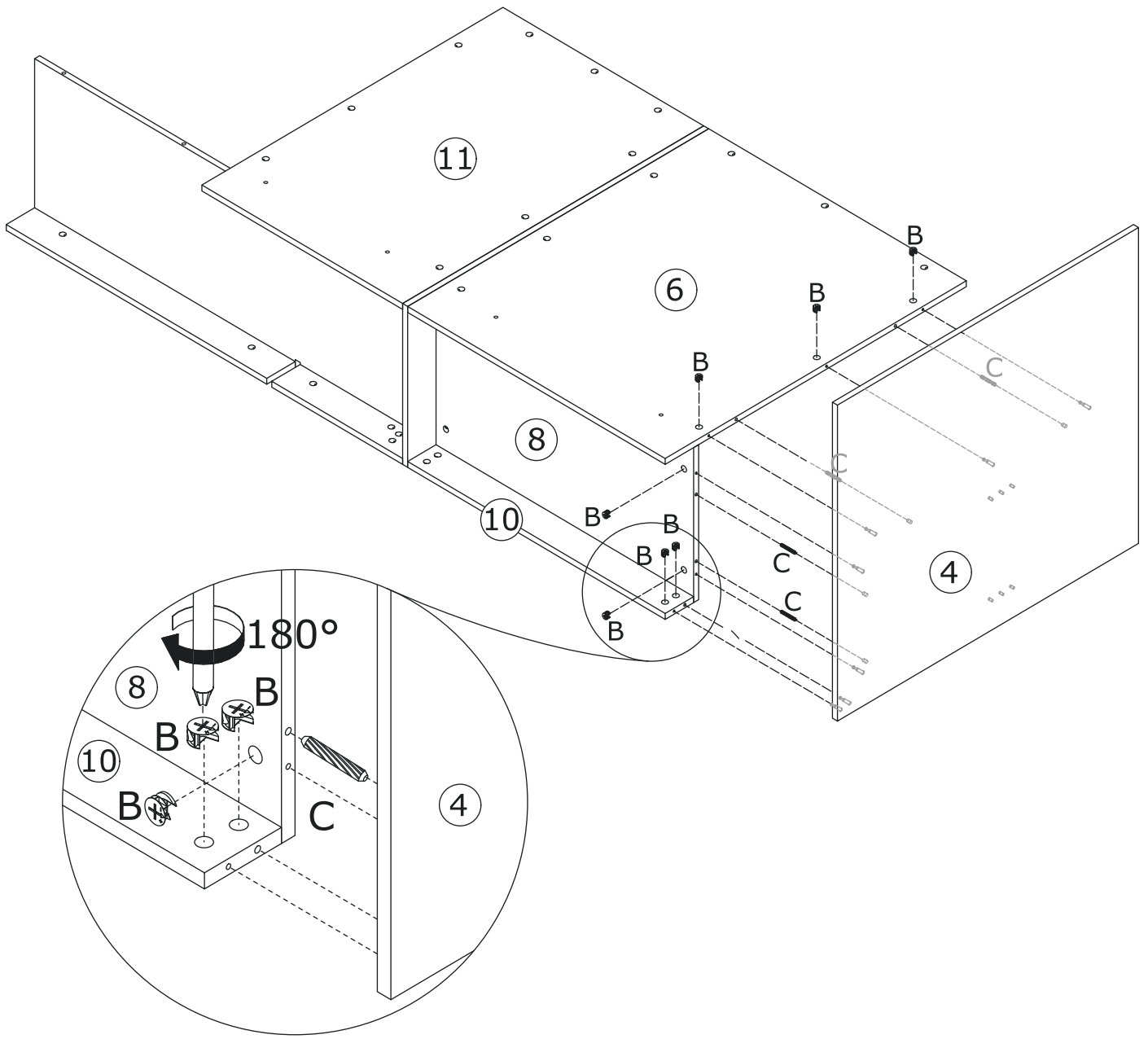
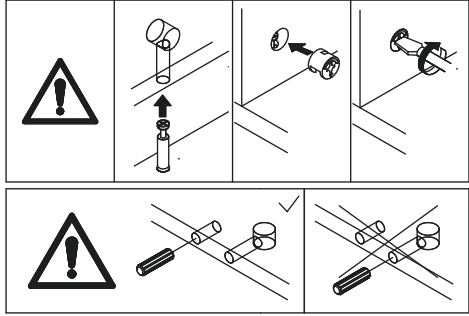

14

A x 12  
Ø6 x 35 mm

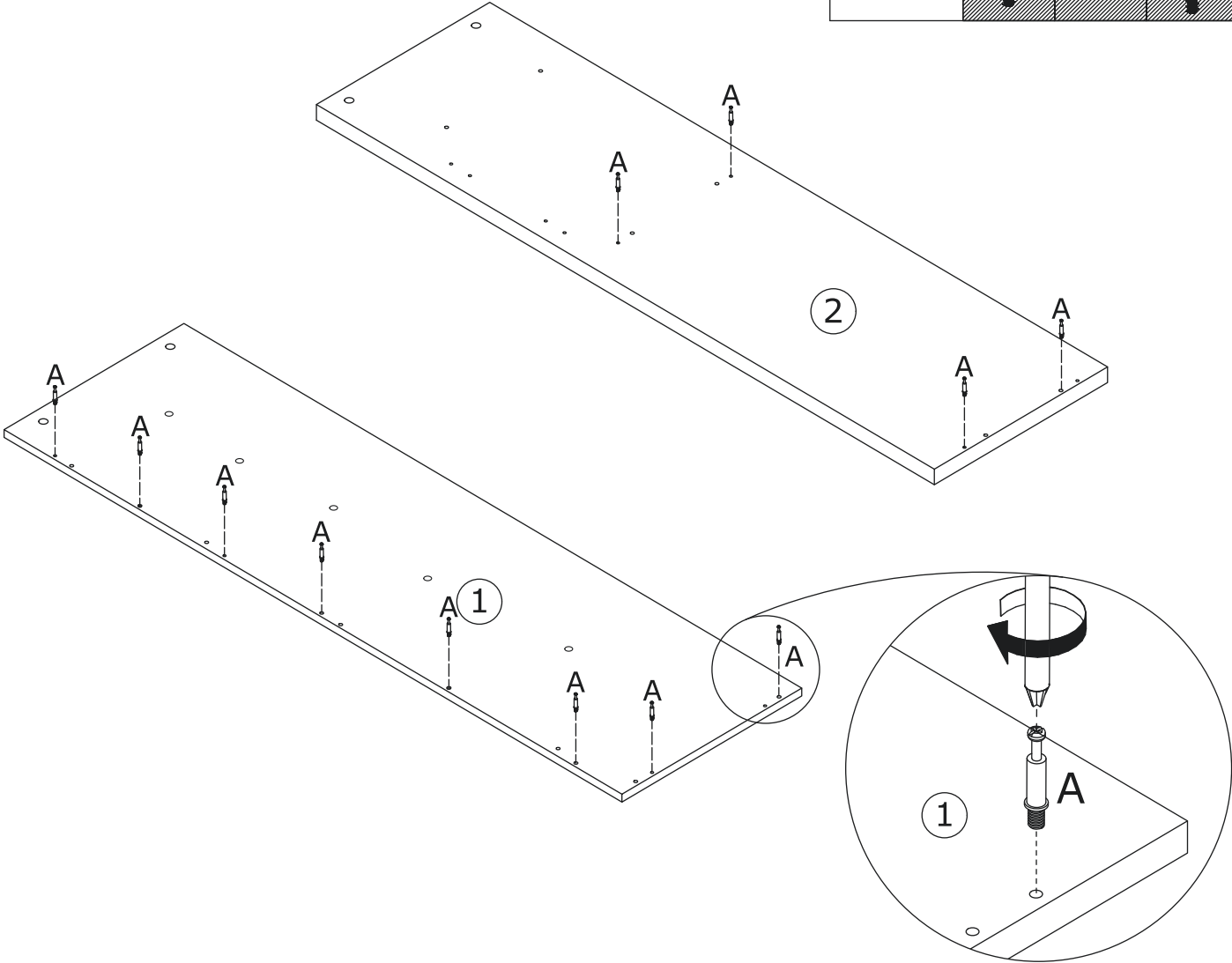
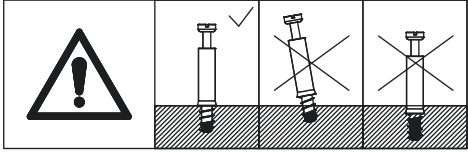
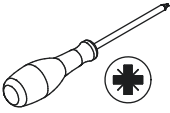

Screw eccentric rod(A)  
into board 1 and 2 at first.

15

Insert plate 23.

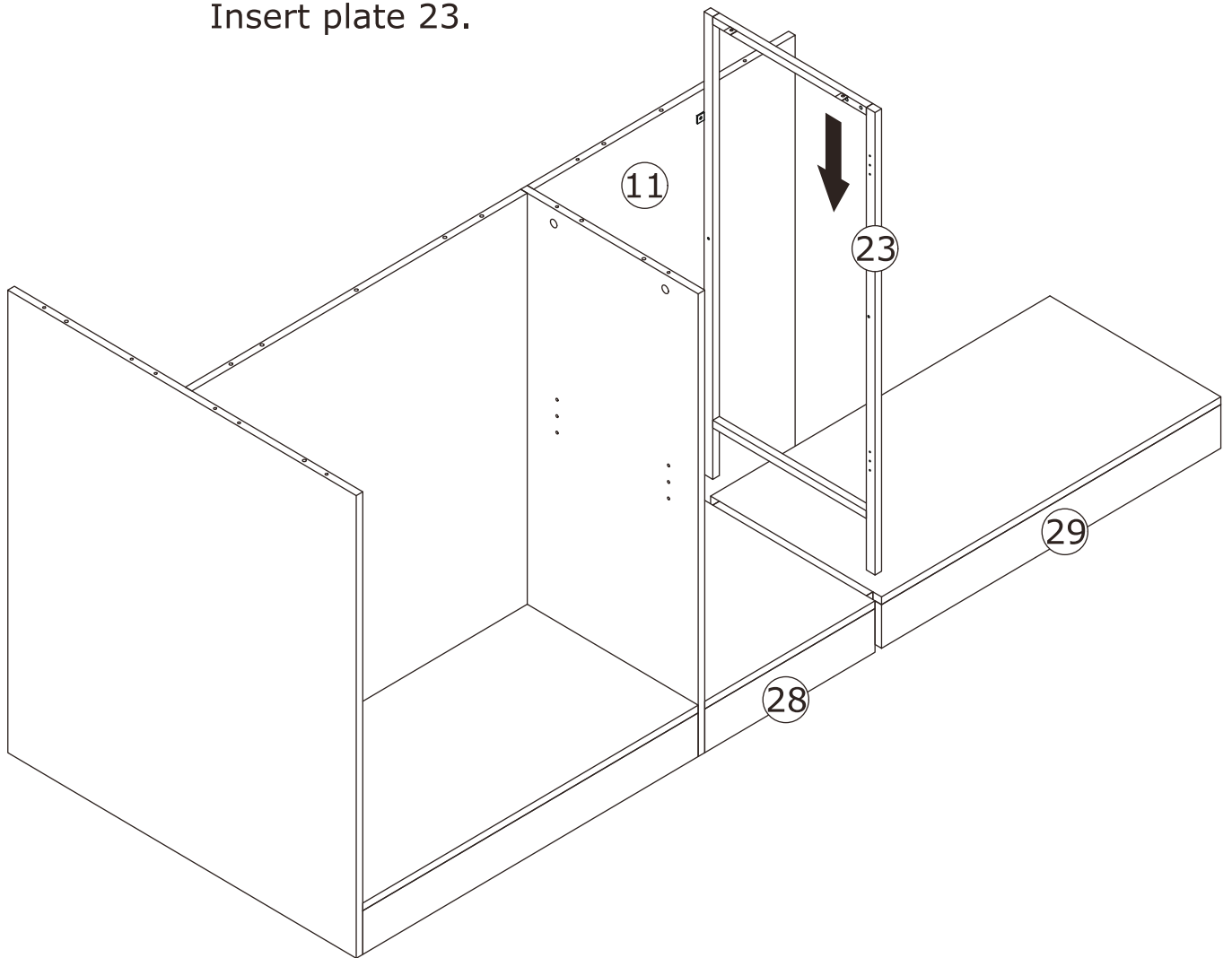

16

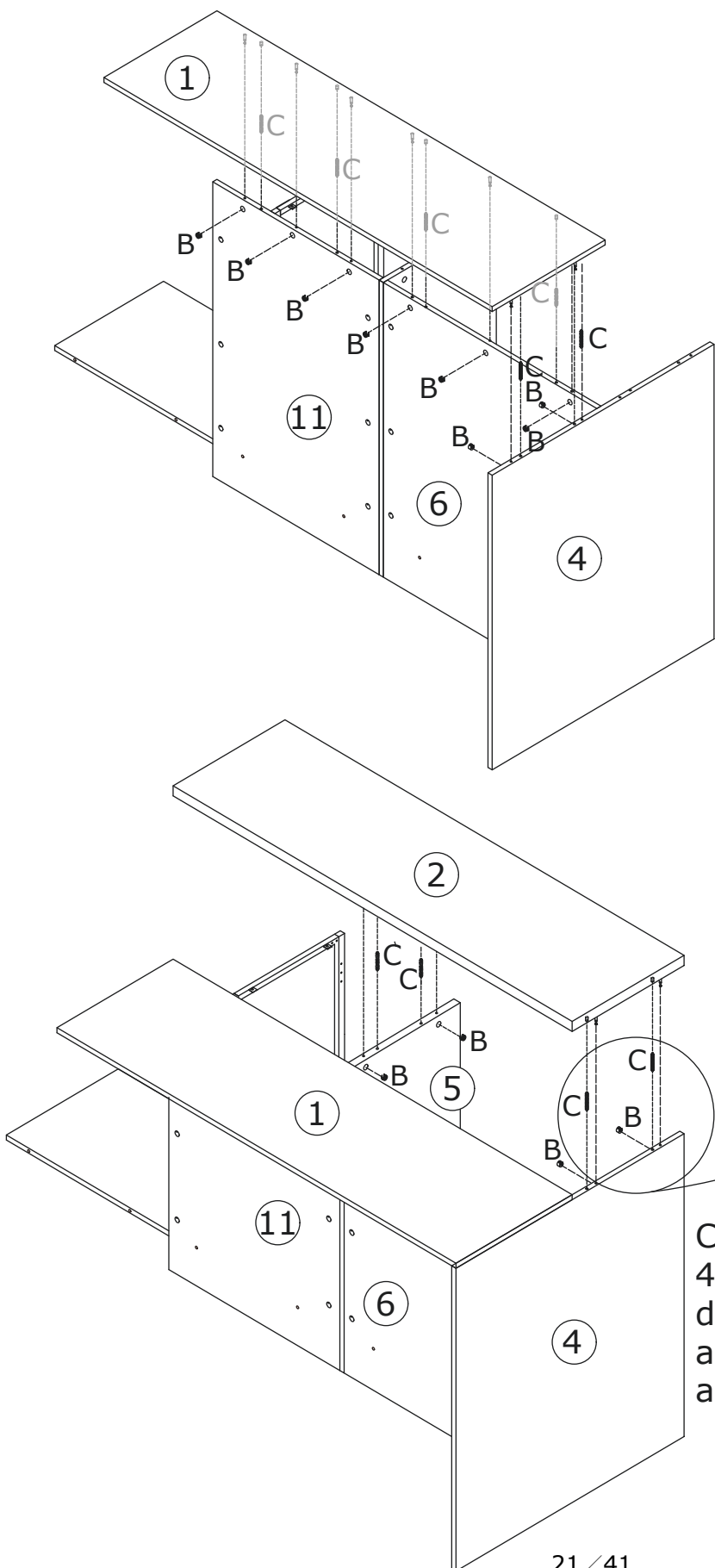
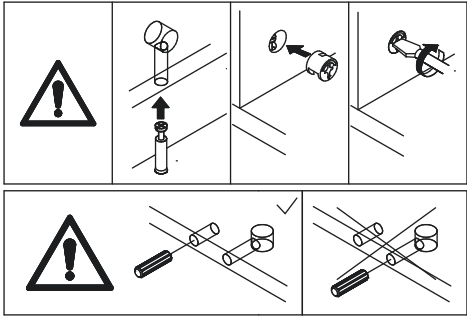
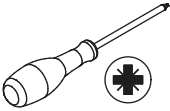
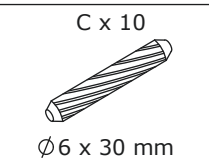
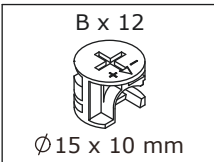

Cover board 1 and 2 to board 4, 6, 5 and 11 using wooden dowel(C), add cam lock(B) into and turn clockwise to tighten as shown.

17

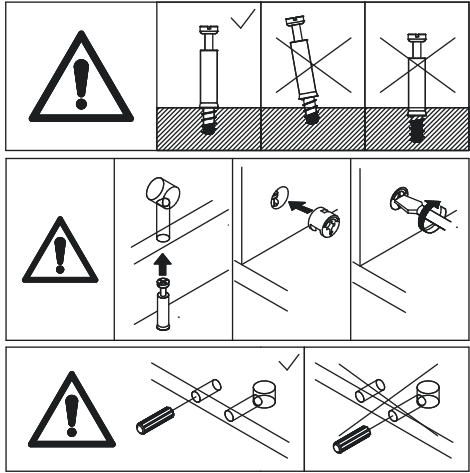
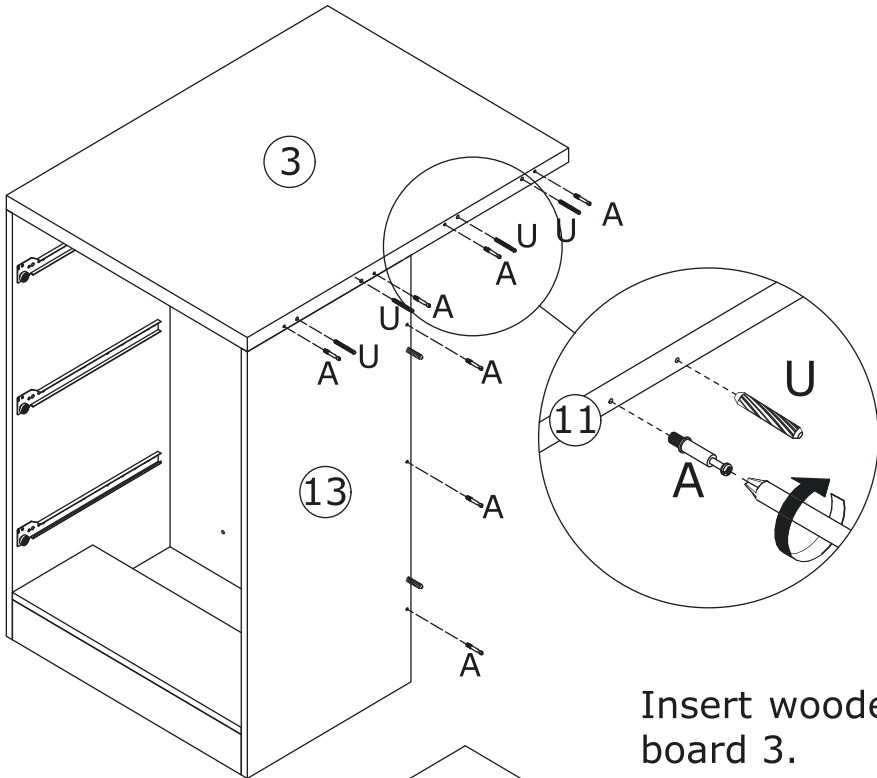
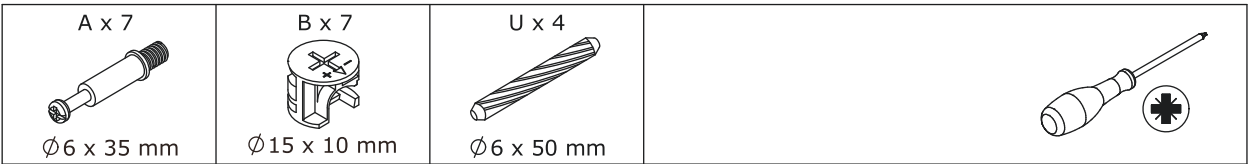

Screw eccentric rod(A) into board 3 and 13 at first.

Insert wood dowel(U) into board 3.

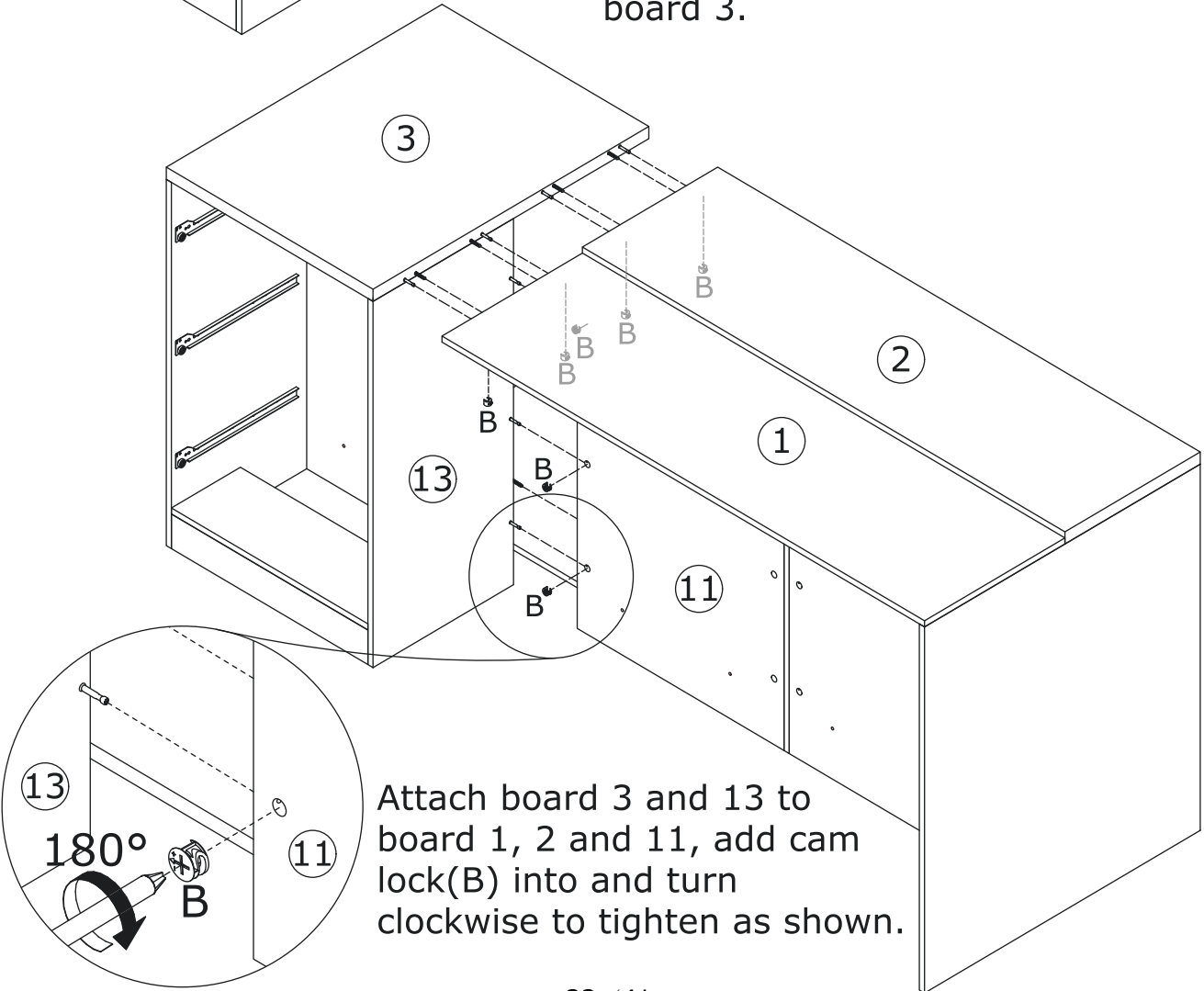

Attach board 3 and 13 to board 1, 2 and 11, add cam lock(B) into and turn clockwise to tighten as shown.

18

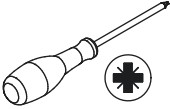
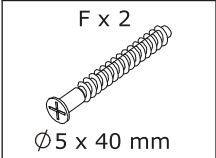

Fix board 15 to board 26 with screw(F) as shown.

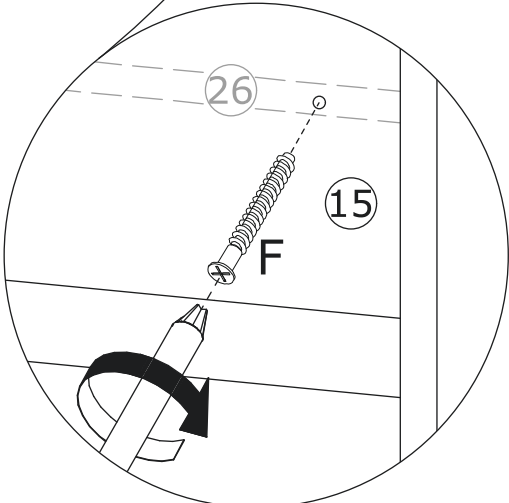
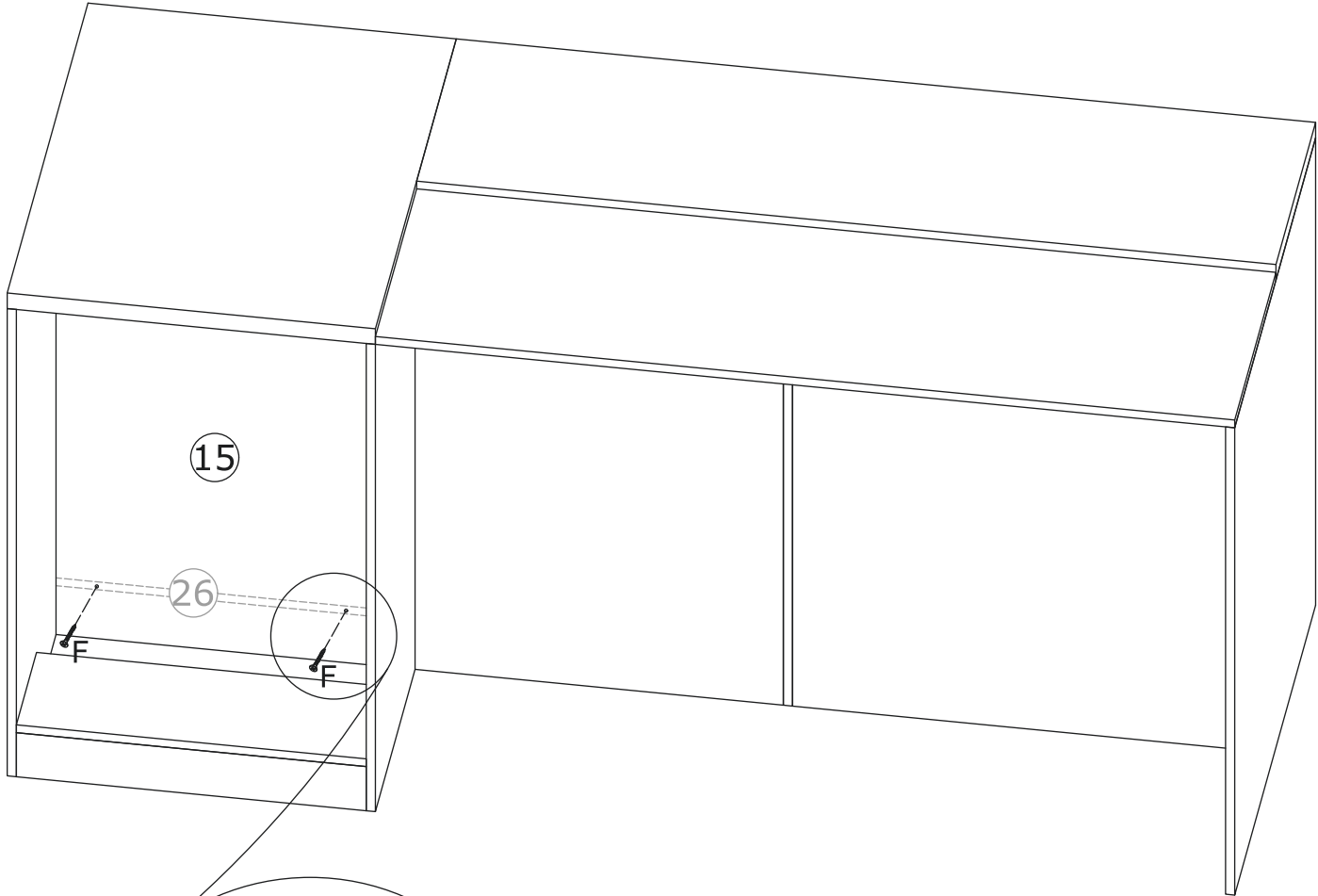

# 19

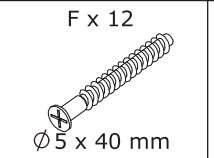
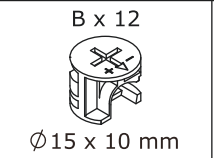

Screw eccentric rod(A)  
into board 16 at first.

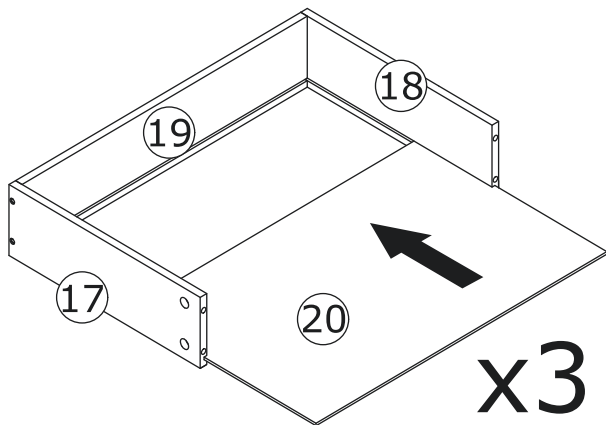
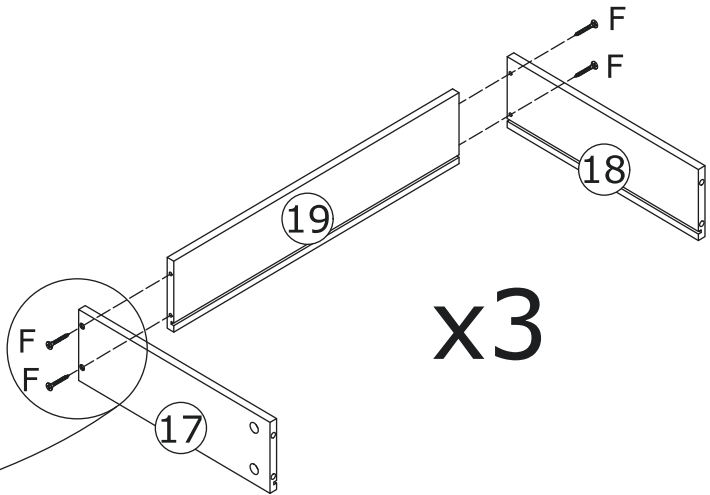
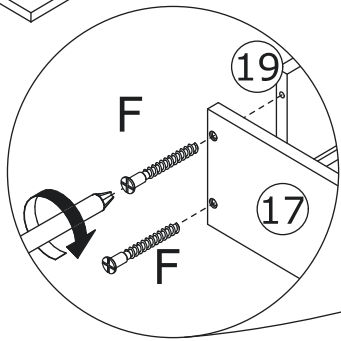
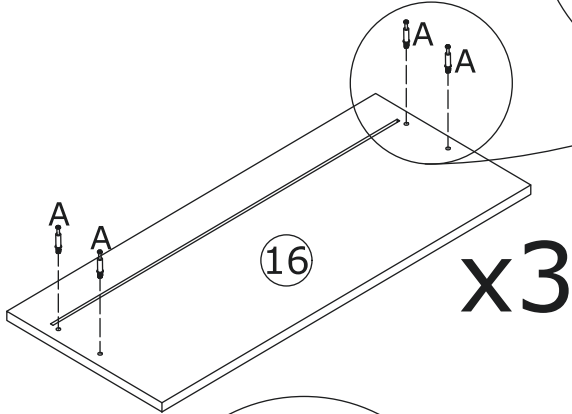
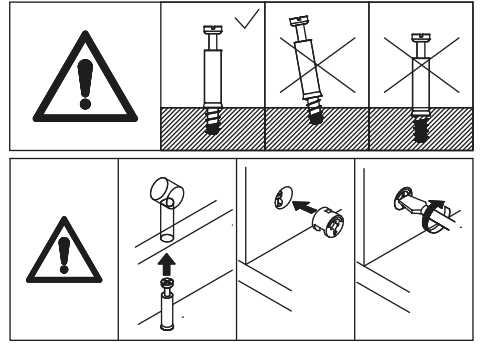
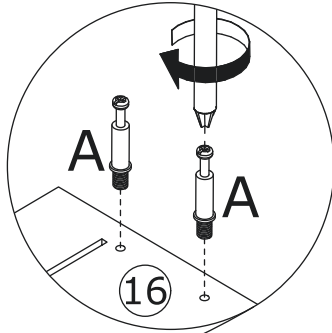

Fix board 19 to board 17 and 18  
with screw(F) as shown.  
Insert bottom board 20 along  
available grooves as shown.  
Attach board 16 to board 17 and 18,  
add cam lock(B) into and turn  
clockwise to tighten as shown.

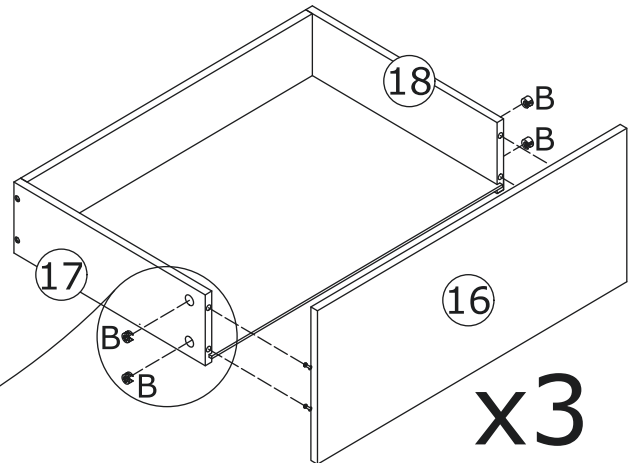
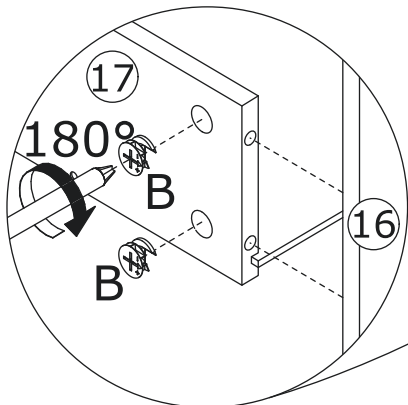

20

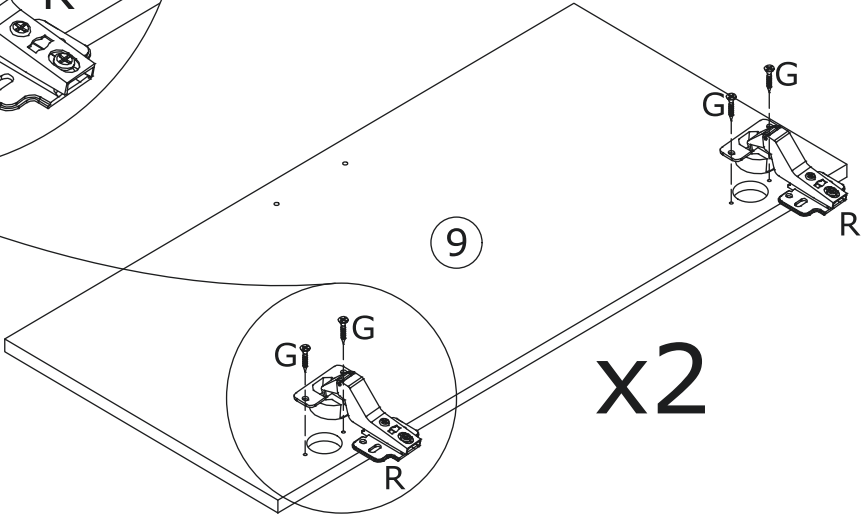
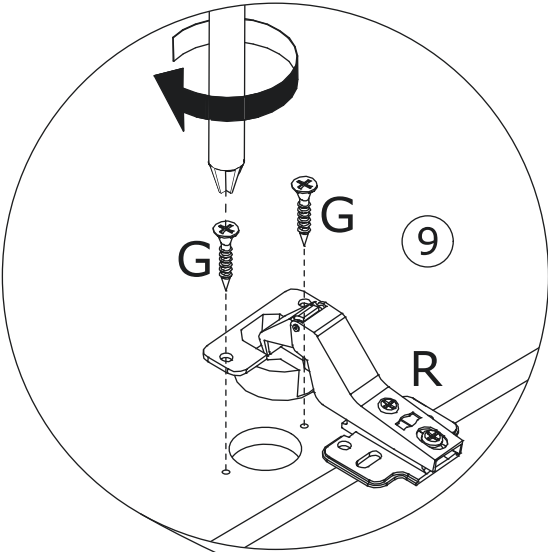
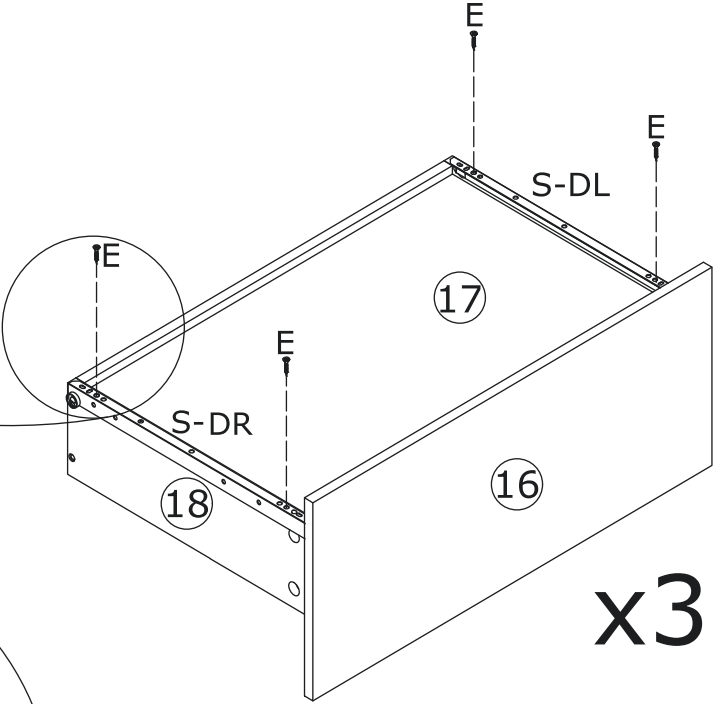
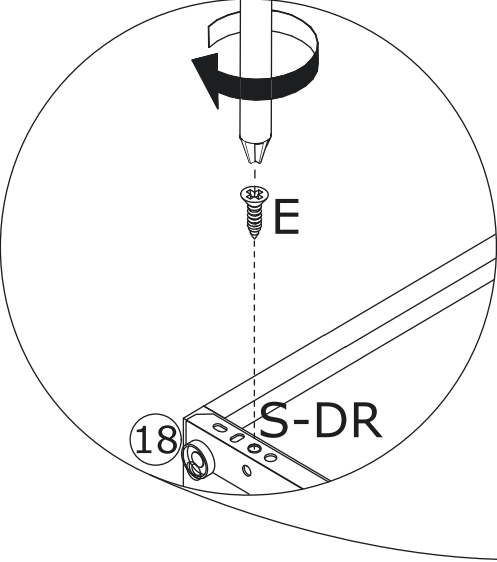
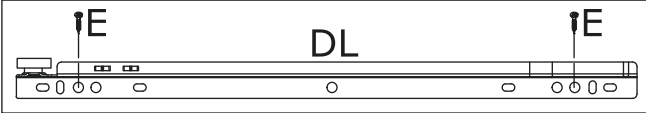
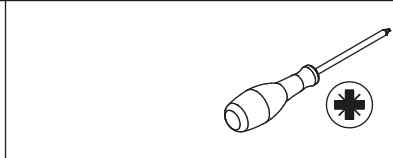
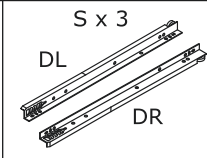
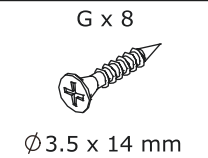
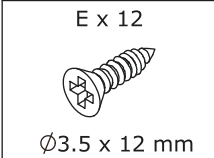

Fix runner(S-DL) and (S-DR) to board 17 and 18 with screw(E) as shown.

Fix hinge(R) to board 9 with screw(G) as shown.

21

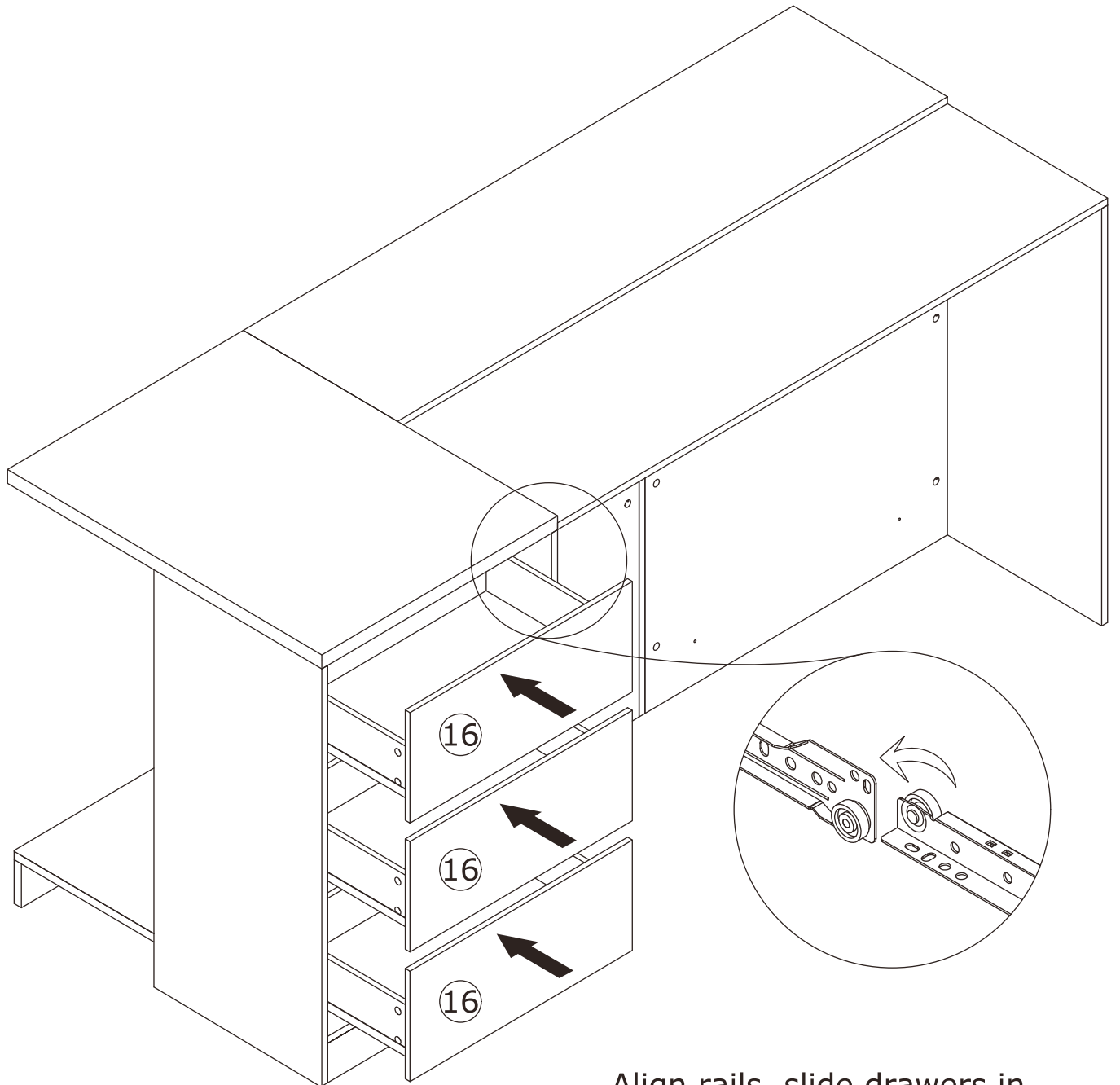

Align rails, slide drawers in.

22

G x 2  
Ø 3.5 x 14 mm

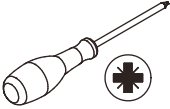

Fix plate 23 to board 2 with screw(G) as shown.

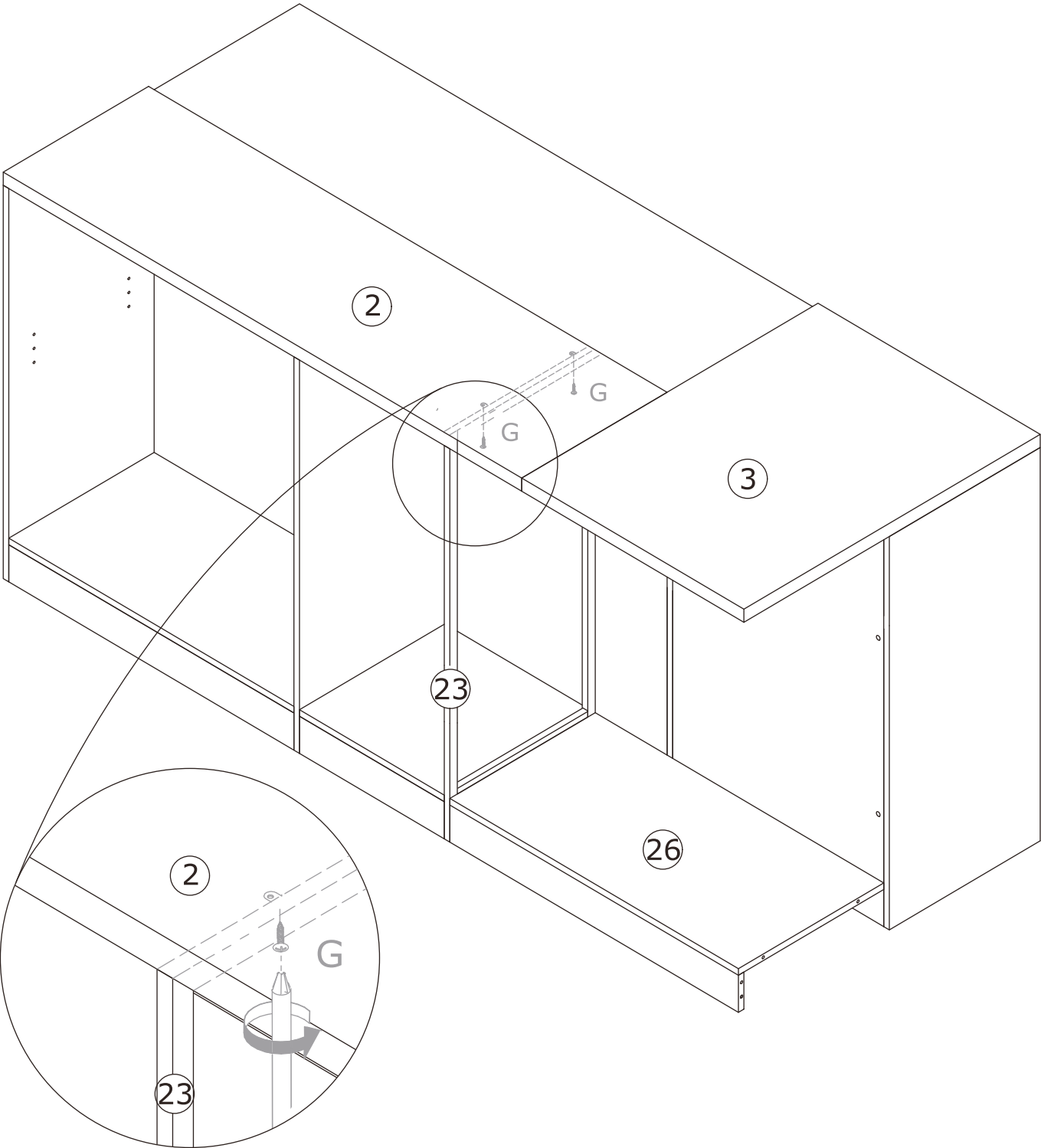

23

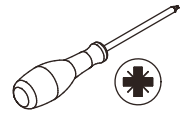
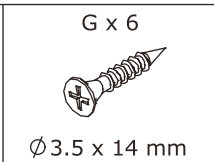
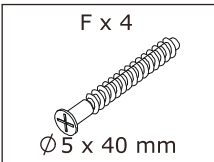

Fix plate 24 to board 26 and 29 with screw(F) as shown.

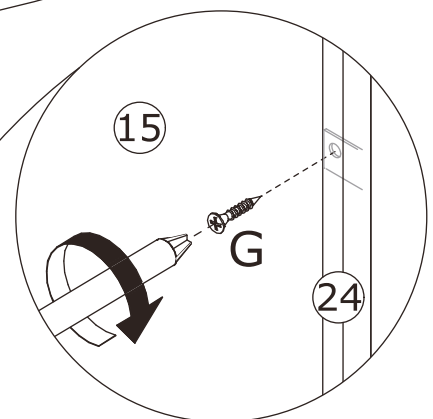
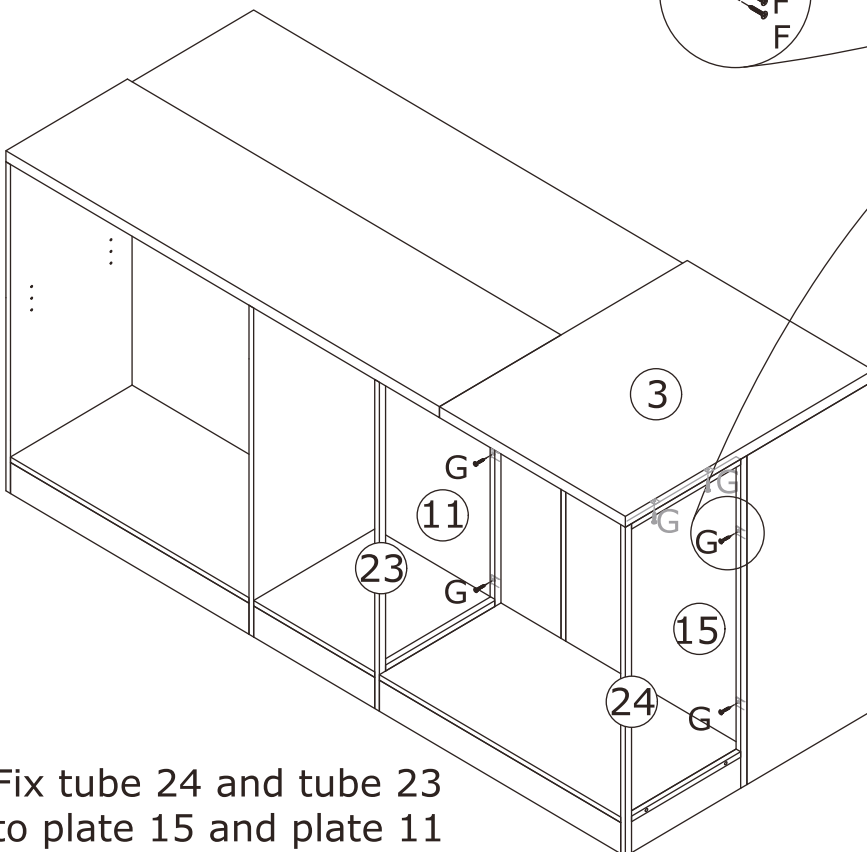
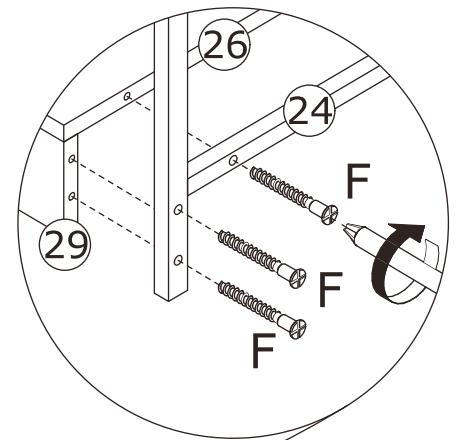
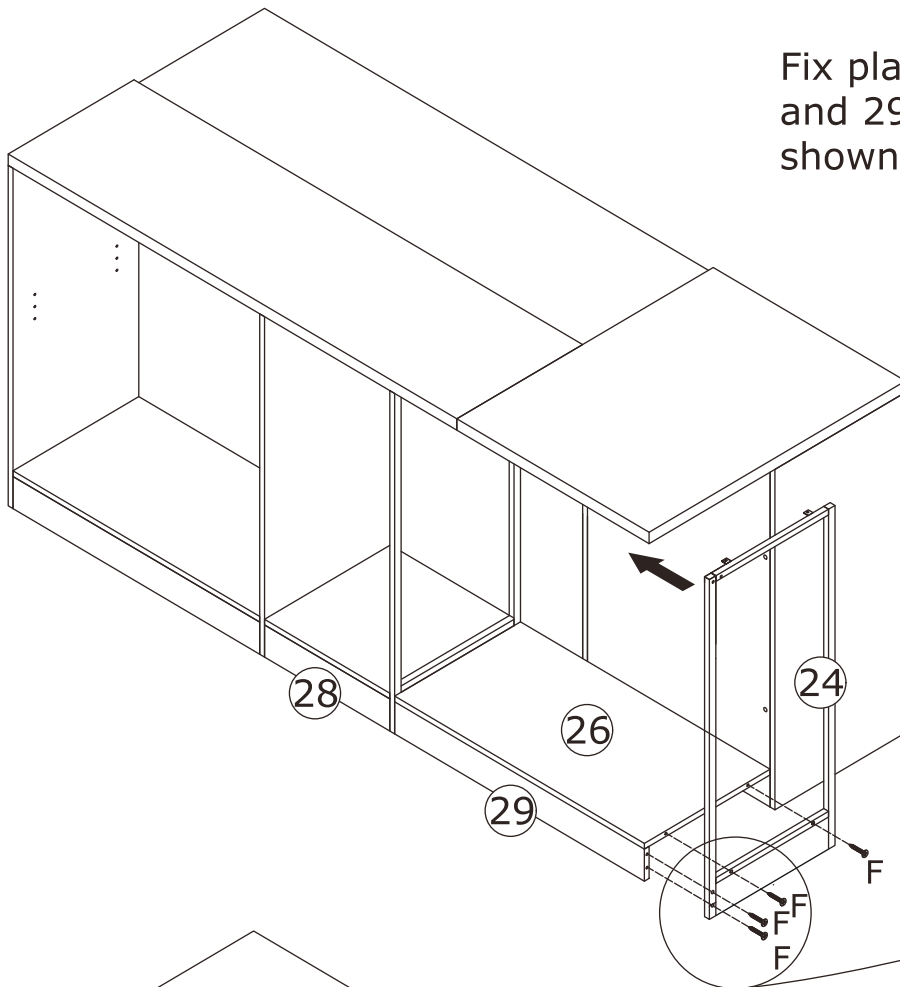

Fix tube 24 and tube 23 to plate 15 and plate 11 with screw(G) as shown.

24

O x 4



Insert layer pin(O) into board 4 and 5, then place shelf board 7 on.

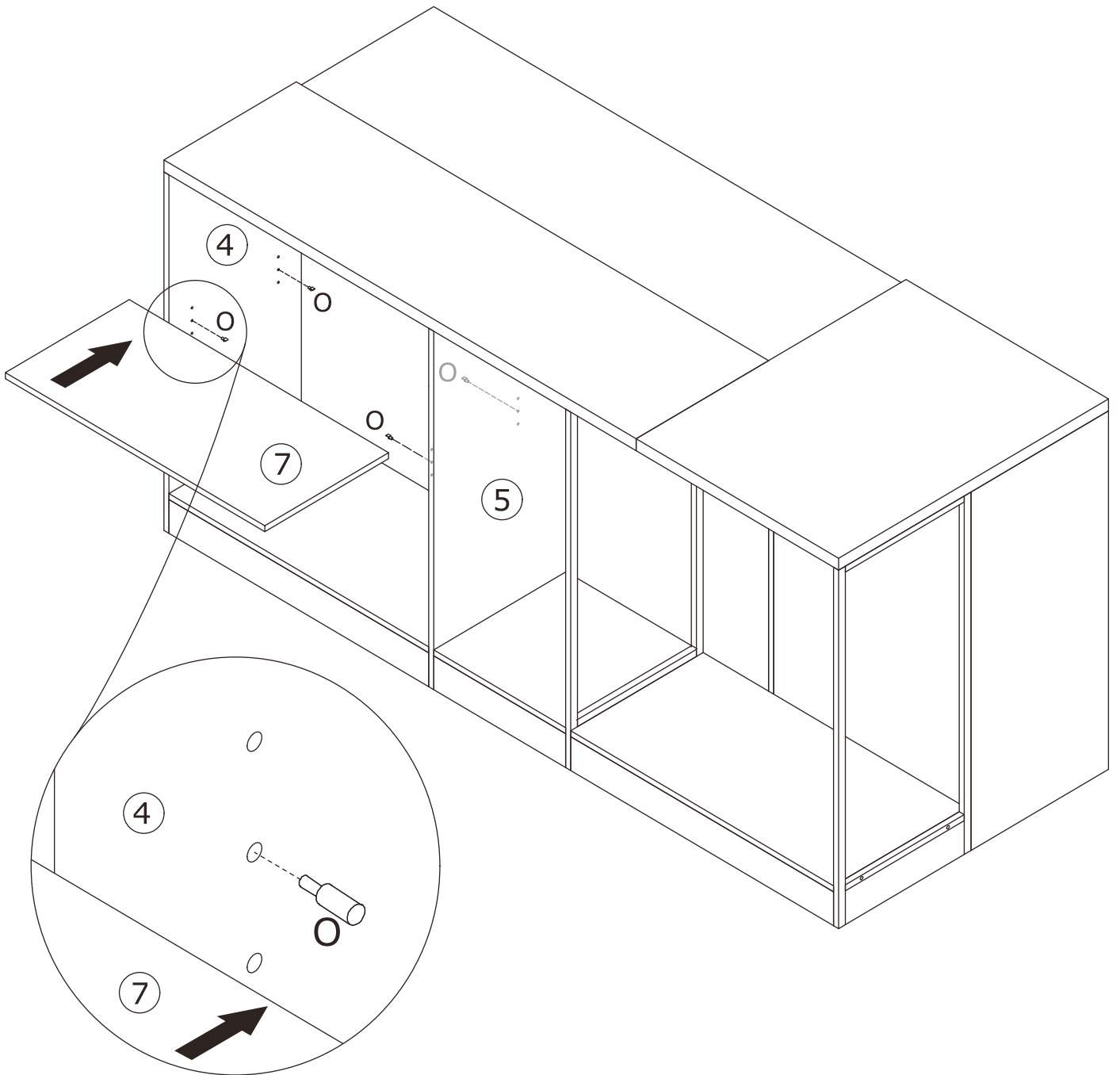

25

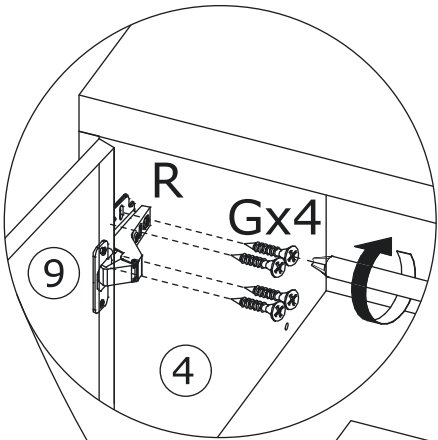
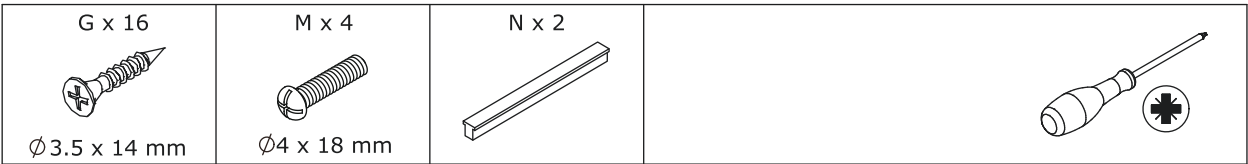

Assemble door 9 to board 4 and 5 by fixing hinge with screw(G) as shown. Fix handle(N) with screw(M).

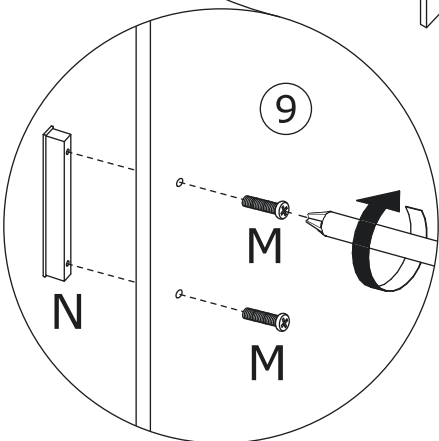
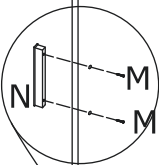
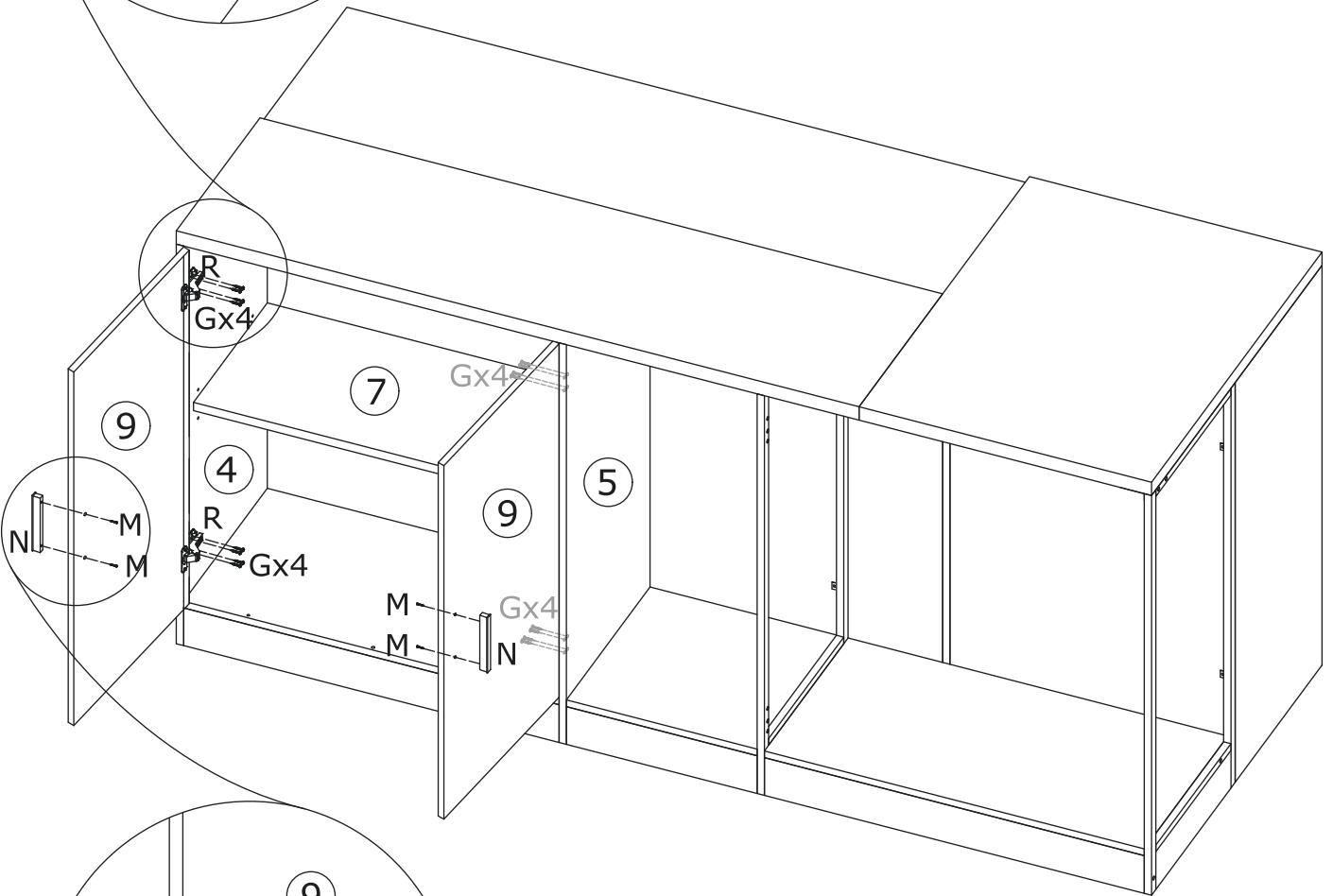

26

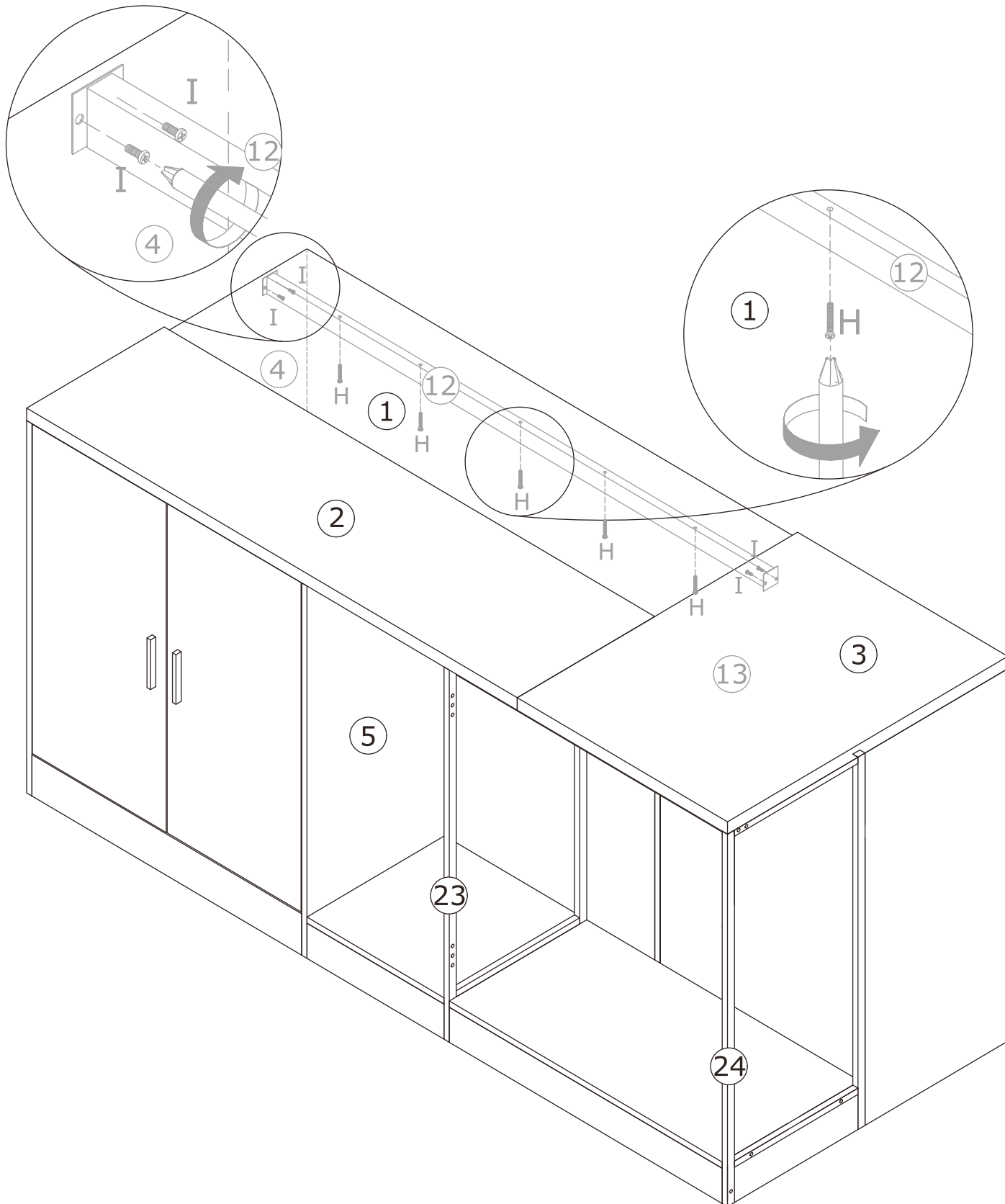
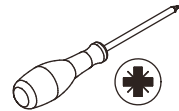
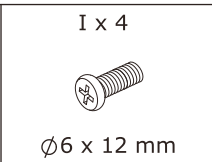
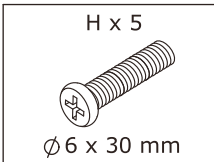

Fix tube 12 to board 4 and 13 with screw(I);  
to board 1 with screw(H) as shown.

27

F x 4  
Ø5 x 40 mm

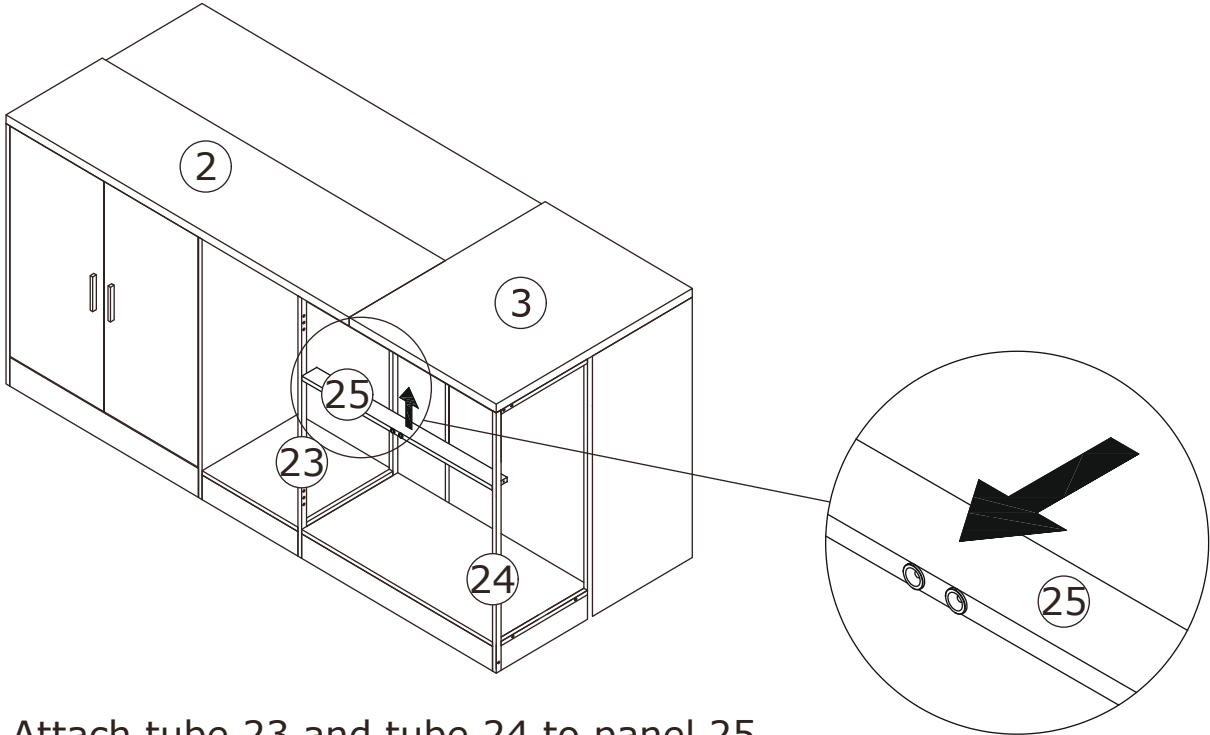
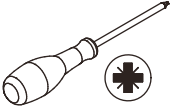

Attach tube 23 and tube 24 to panel 25 using screws (F).

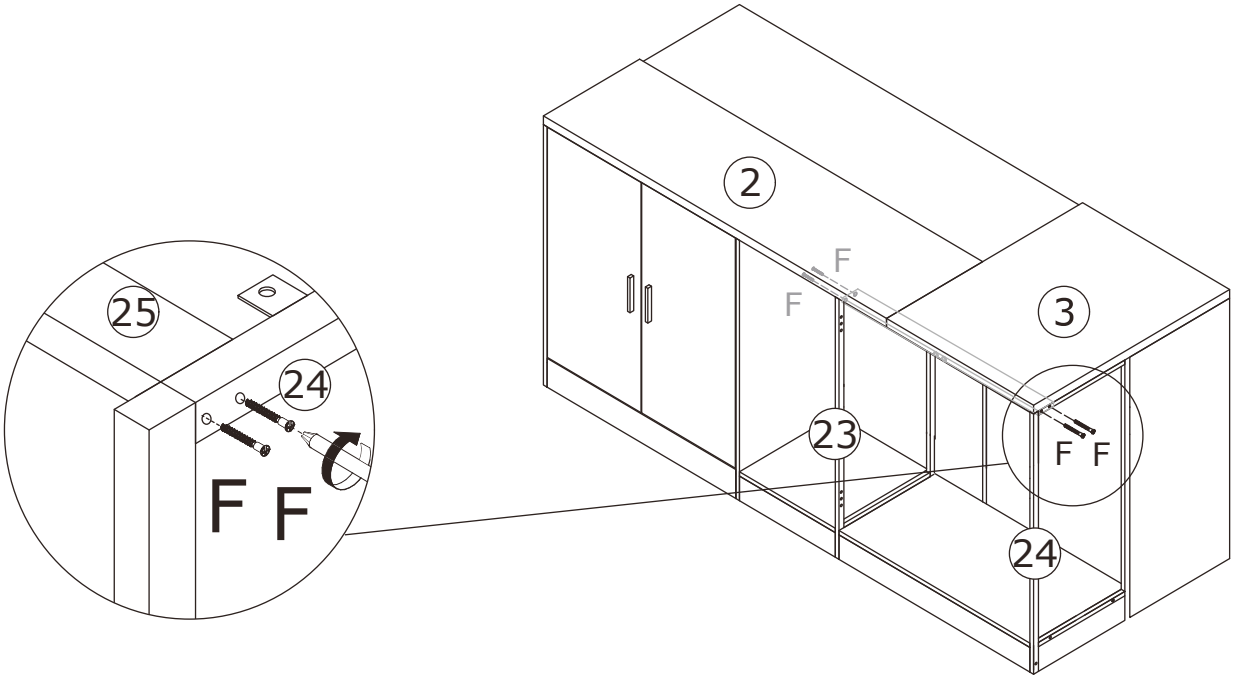

28

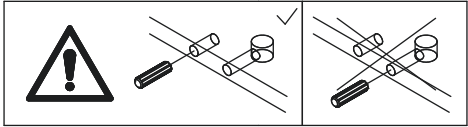
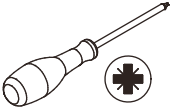
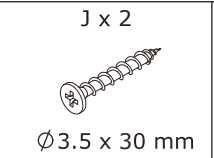
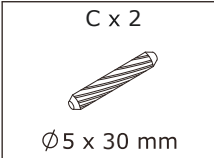

Attach panel 33 to panel 2 using screws (J) and wooden dowels (C).

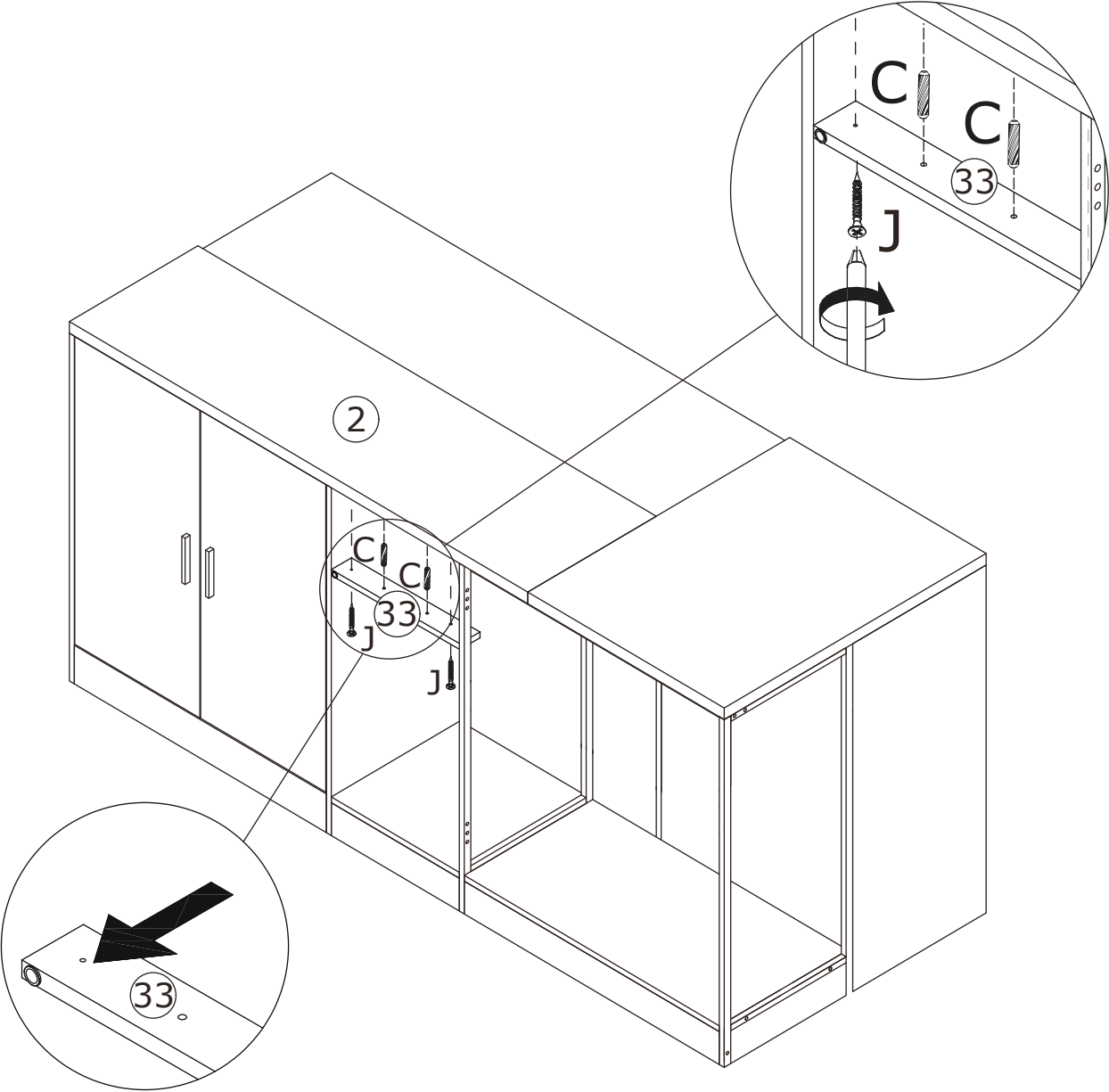

29

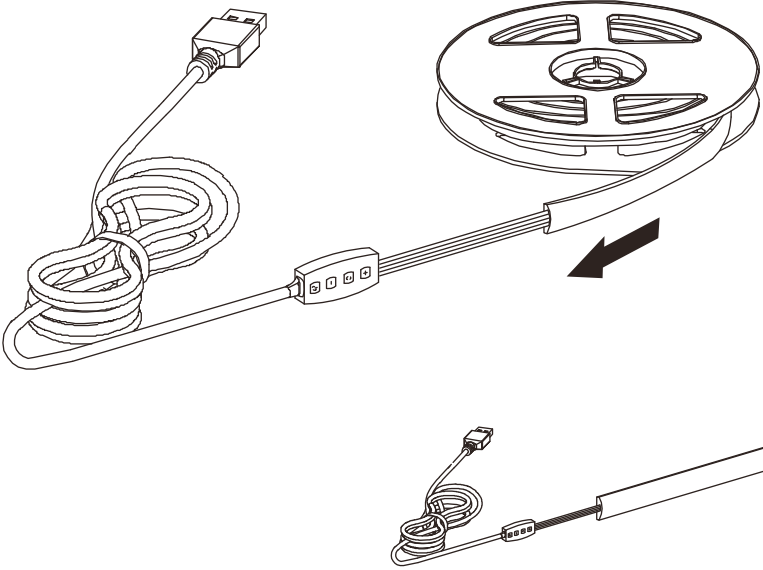

Open the package and get the LED strip, clean the boards. keep the boards dry.

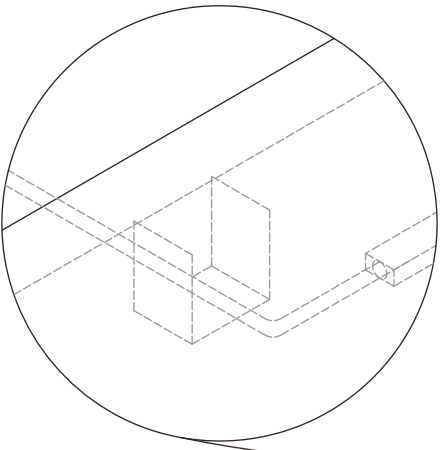

Thread the strip through the bottom hole to the top as shown.

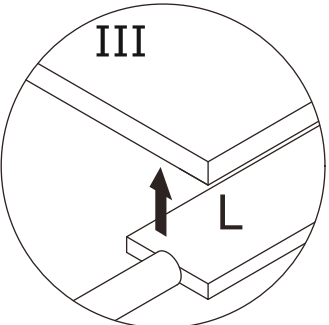
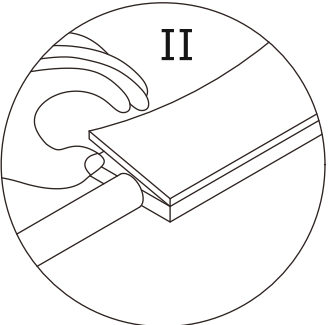
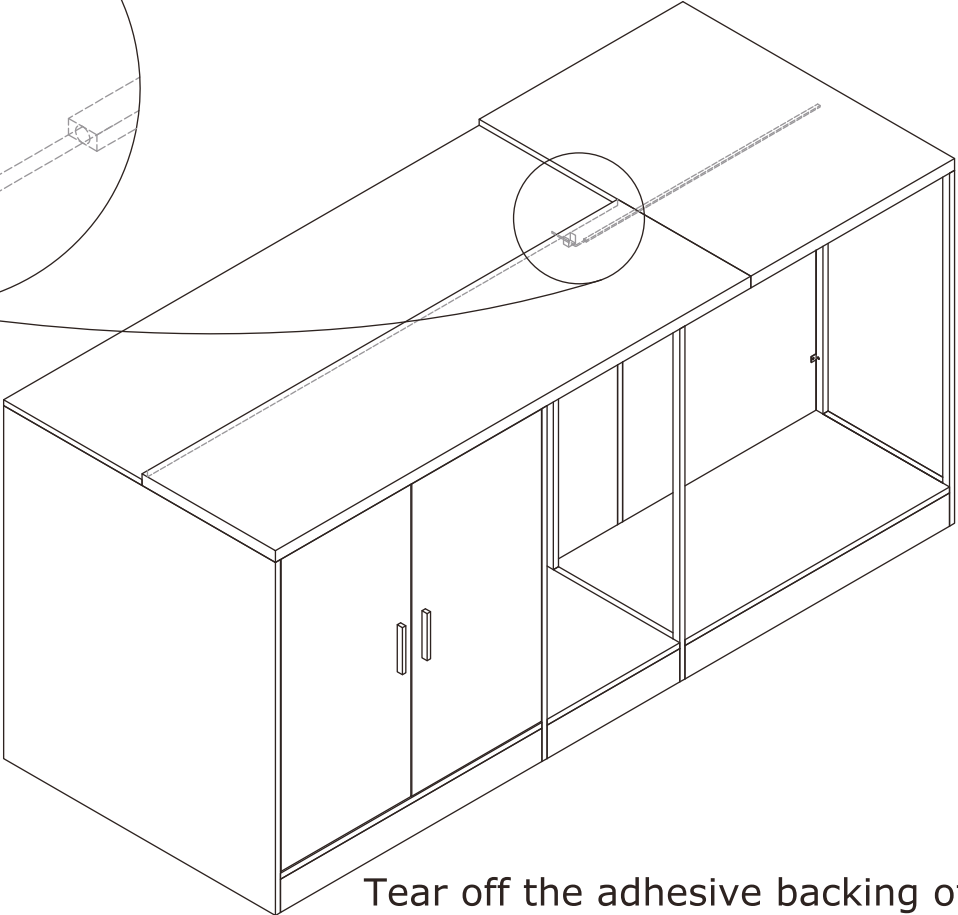

Tear off the adhesive backing of the light strip, stick the strip to the bottom from the top cabinet as shown.

30



Fix iron bar 30 to board 5 with screw(G);  
to plate 23 and 24 with screw(T) as shown.

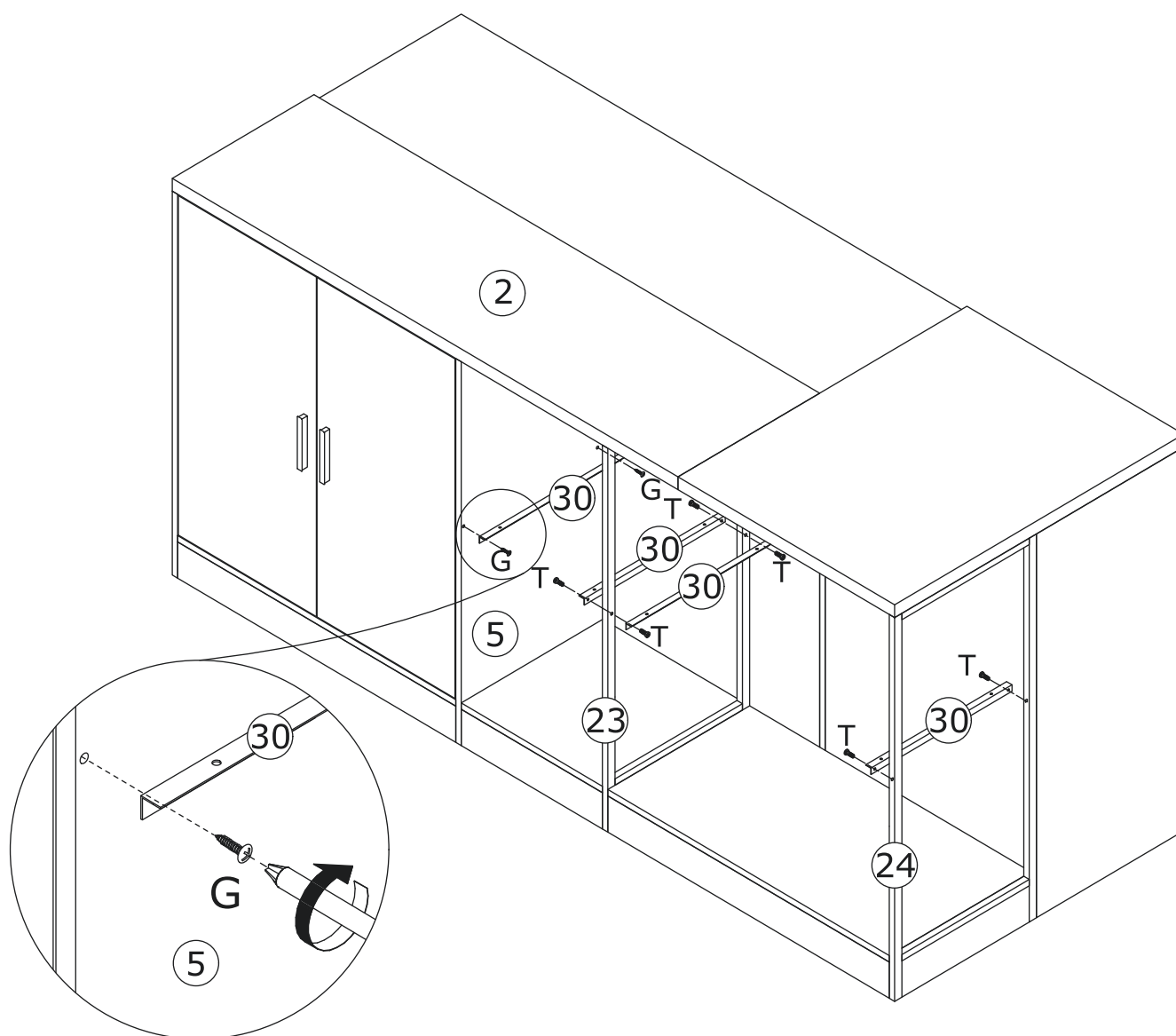

31

Q x 8



Insert layer pin(Q) into iron bar 30,  
then place glass board 31 and 32 on.

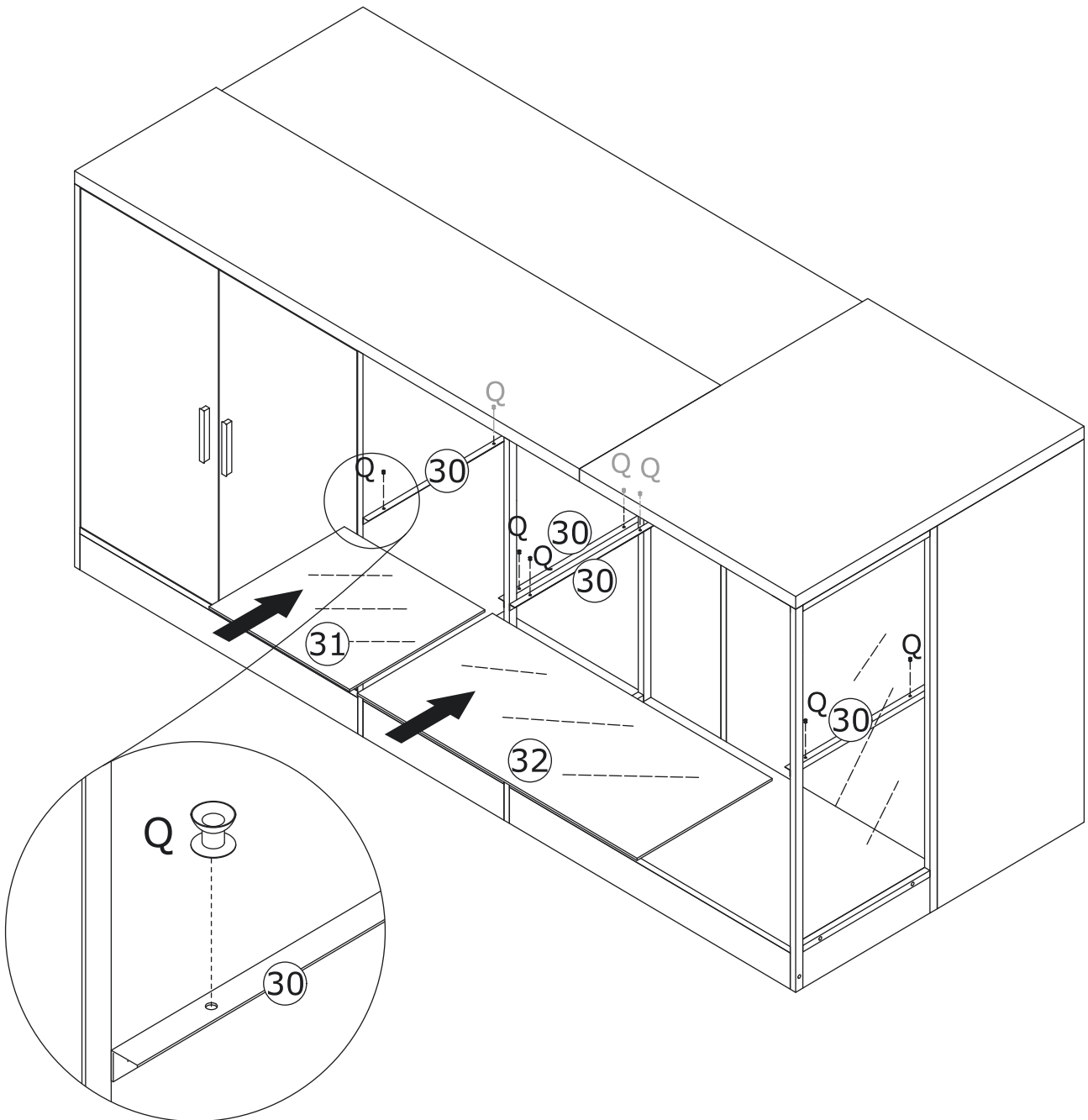

32

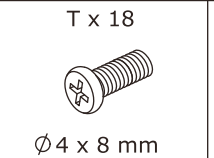
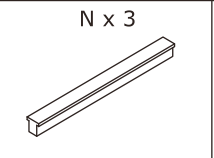

Fix handle(N) with screw(M).

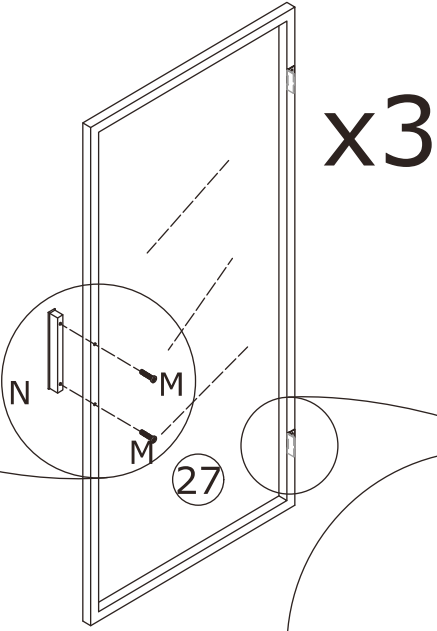
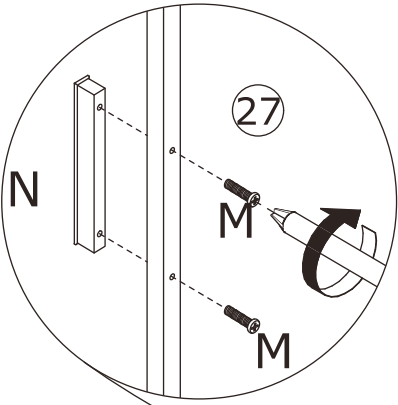

Assemble door 27 to plate 24 and 23 with screw(T) as shown.

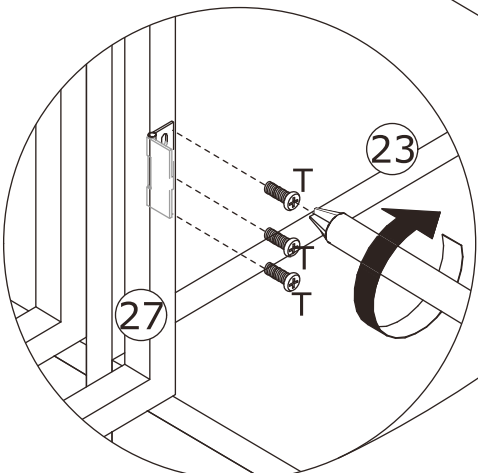
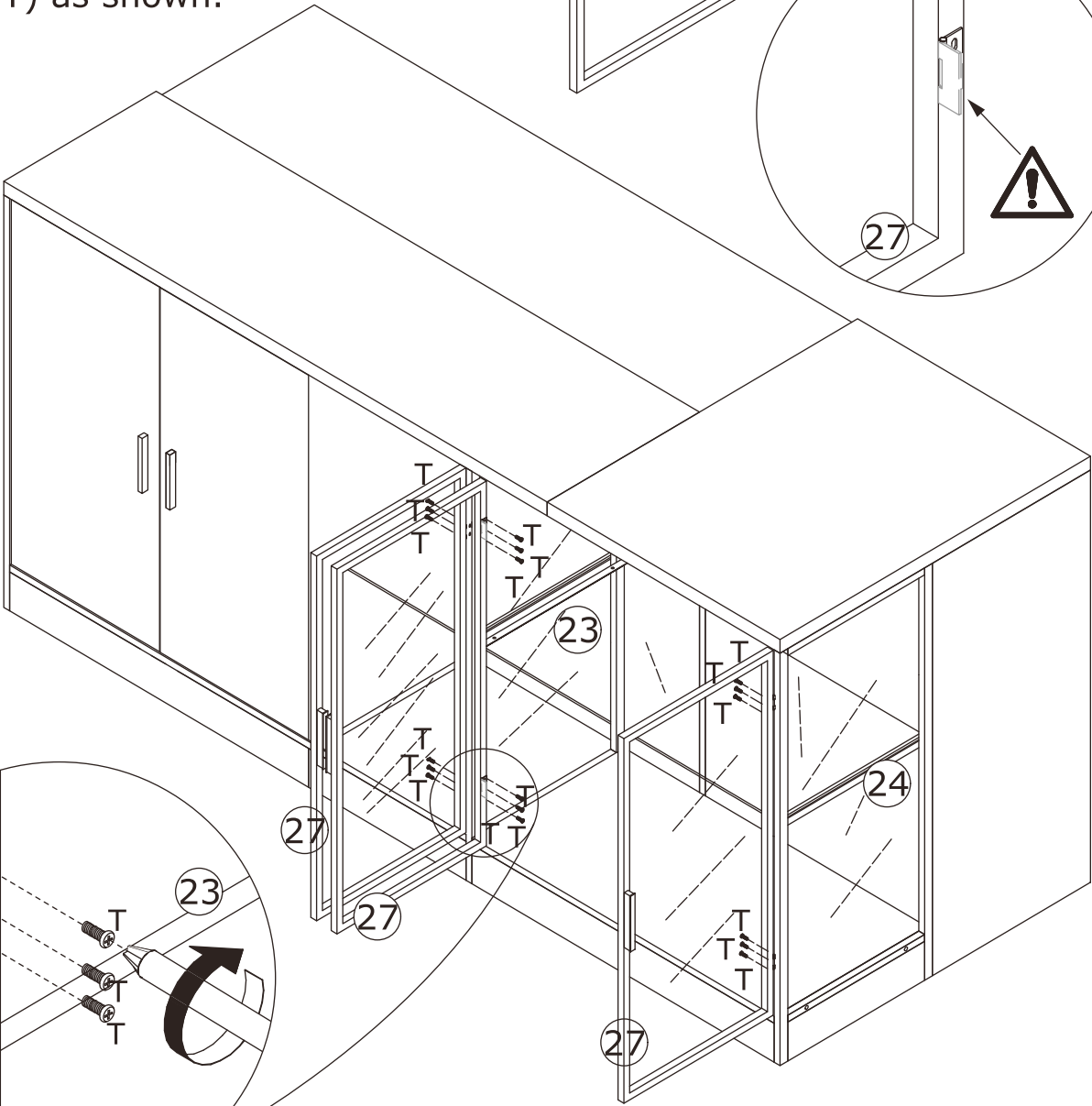
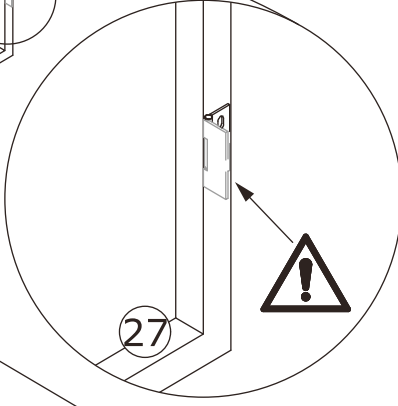

33

P x 20

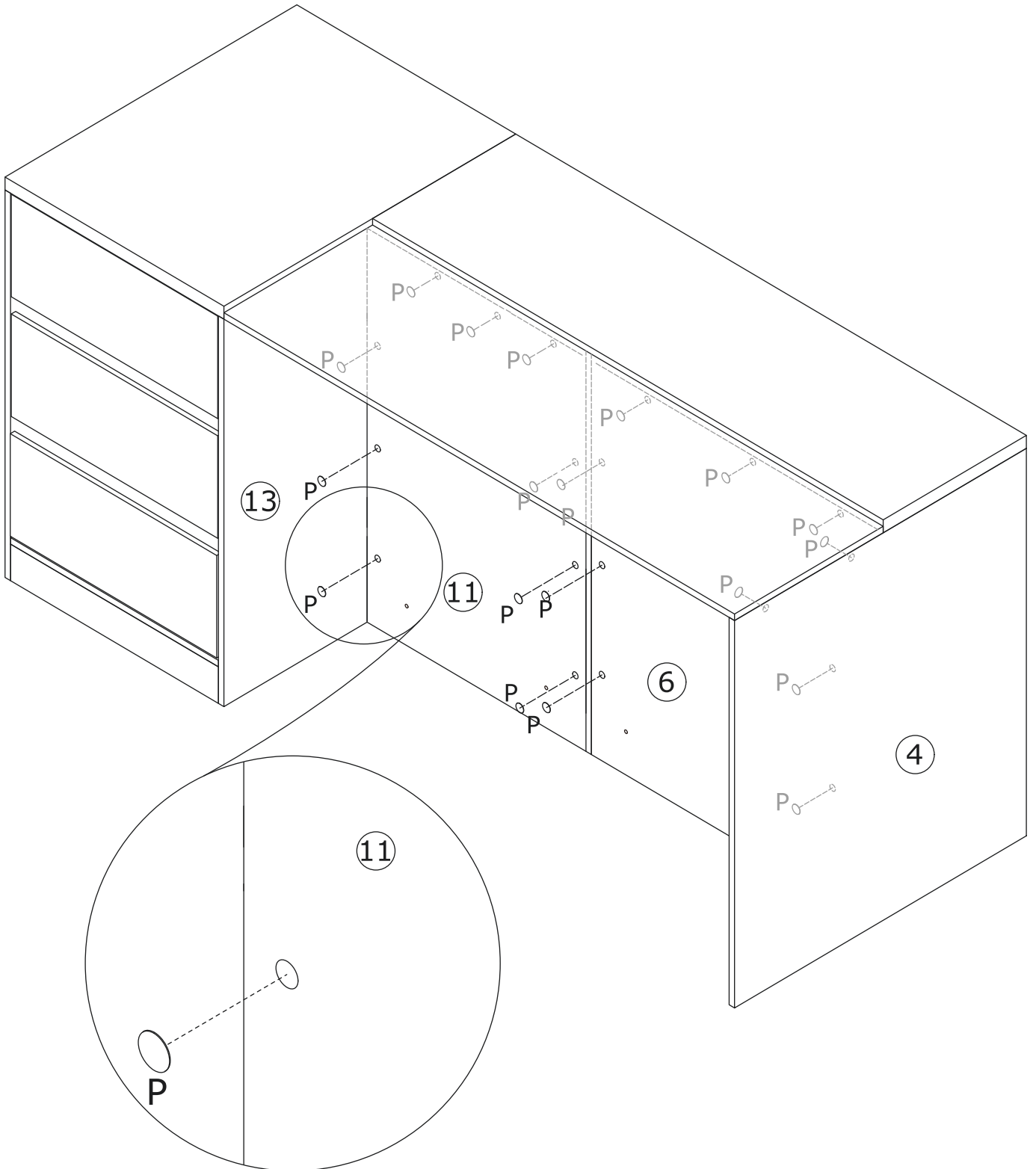
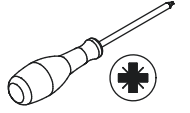

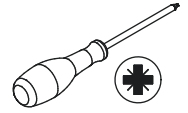

If doors are still not aligned if the hinges are properly correctly, please watch the video.

[Hinge adjustment video number 1:, <https://www.youtube.com/watch?v=FKGoPsgsb6M>]

[Hinge adjustment video number 2:, <https://www.youtube.com/watch?v=747vm8CJS3I>]

[Hinge adjustment video number 3:, <https://www.youtube.com/watch?v=X1ImHtTLUoU>]

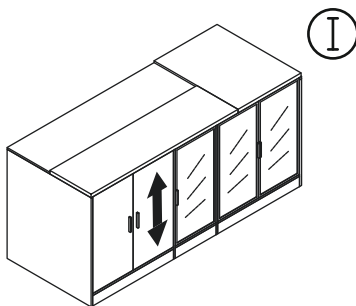
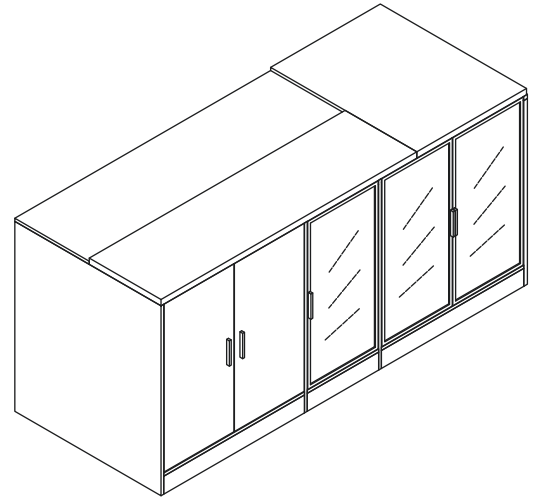

I

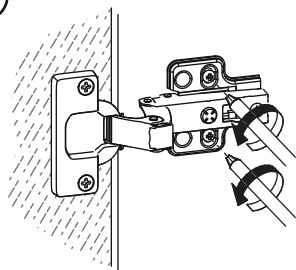

II

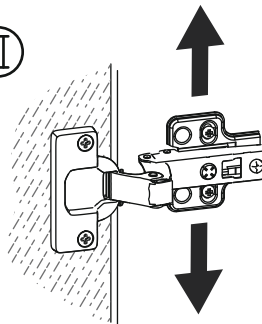

III

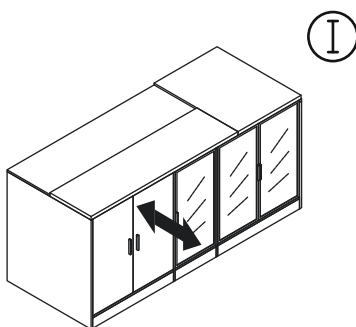
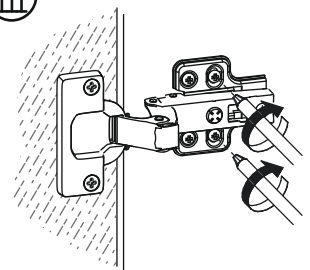

I

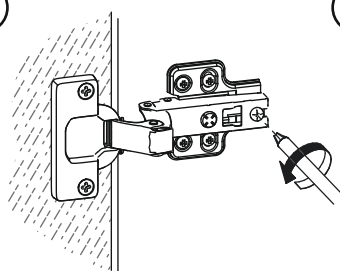

II

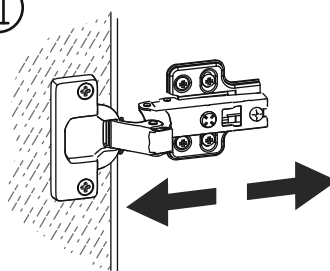

III

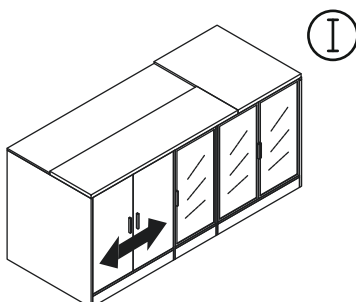
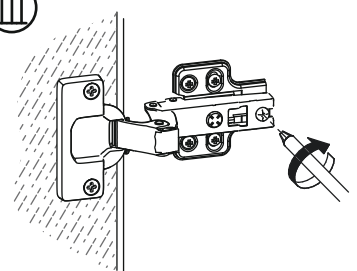

I

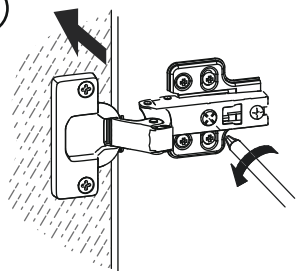

II

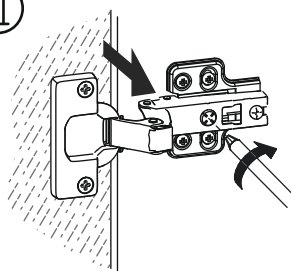

# WARRANTY

## WARRANTY CLAIMS

- There is a 30-day warranty for broken furniture or any other problems that do not work properly. The warranty will start from the date of purchase which must be verified by proof of purchase.
- Before making a claim, we may be able to answer your query, simply call us. Please leave your purchase order number, along with some details of the problem, if you want a replacement part. We will arrange within 48 hours. If there is out of stock, we will reply with a shipping date.
- The product must be used in accordance with the instructions provided. For health reasons.
- For other reasons, if the furniture needs to be returned, it must be cleaned and dried and operated within 30 days of receipt.

## Type of Warranty Claim

- Failure to follow the furniture instructions will invalidate the warranty. Attention please.
- Does not include damage during installation, but includes damage during transportation.

## Scope of responsibility

- Shall not bear any responsibility for misuse or user damage and / or loss of parts during the installation of furniture.
- After using, the damage and scratches of the furniture are not covered by the warranty.

## The Warranty Relates to All Bought in The Us and Covers The Following Areas

- Sheet parts: 1 month from the date of purchase.
- Electrical parts: 1 month from the date of purchase.

# RETURNS

## CHANGED YOUR MIND AND NEED TO RETURN YOU ITEM?

### PLEASE FOLLOW THE BELOW INSTRUCTIONS:

- If you have purchased and have simply changed your mind, follow the retailer's instructions for returns.

### DEFECTIVE ITEMS

- If your item is defective in any way, i.e. it doesn't work but you can't identify why, in the first instance, please call us.

### DAMAGED ITEMS

- If you receive an order with obvious shipping damage from the retailer, then we suggest the delivery is refused. If the delivery has been accepted and then shipping damage is found, please follow the specific instructions advised by the retailer. In all circumstances please save all packaging material and paperwork for the order. Please be aware that if you dispose of packaging material or attempt to return the merchandise without contacting the fulfiller, you jeopardise your chances of making a claim, and you may not receive a credit for the return.

### AFTER-SALES CONTACT

 [adelahu@fufugaga.com](mailto:adelahu@fufugaga.com)

 208-820-0068