

ASSEMBLY INSTRUCTIONS

End Table



Thank you for purchasing our product!

Please refer and use this assembly instruction to assemble the product.

Contact our customer service department in case there are any missing or damage parts or hardware. Please also tell us your "Order ID", We will solve for you as soon as possible.

ASSEMBLY PREPARATION:

1. Remove all packaging materials, staples and packing straps from the carton.
2. Refer to Parts List and Hardware List and ensure they are correct before assembly. Contact customer service for missing parts.
3. Place all wooden parts on a clean, flat and soft surface (e.g. carpet or rug) to prevent parts from getting scratched.

SAFETY PRECAUTION:

1. Keep all hardware parts out of reach of children.
2. Dispose plastic packaging material immediately to avoid any risk of suffocation to children and animals..

TIPS FOR ASSEMBLY:

1. Allow ample room for assembly and in close proximity to where product will be placed.
2. Assemble the product on a surface that does not scratch or damage the exterior gloss and finish of the furniture.
3. Identify all of the parts, hardware and quantities required for each step.
4. During assembly, do not over-tighten any fittings as this may cause damage.
5. DO NOT USE POWER TOOLS TO ASSEMBLE THIS PRODUCT.
6. Always place the product on a flat, level surface.
7. Do not sit or stand on the partially assembled product; only use the product for which it is intended.

CARE AND MAINTENANCE:

- Use a slightly damp cloth to clean the product. Do not use bleach or abrasive cleaning material.
- Check all the fittings periodically and re-tighten as necessary. Do not use the product if any of the parts is damaged or broken.
- Never allow any kind of liquid to remain on your furniture. Absorption can cause wood to warp or delaminate.
- Do not place hot items (e.g. hot drinks) directly onto the wood surface.

Part List



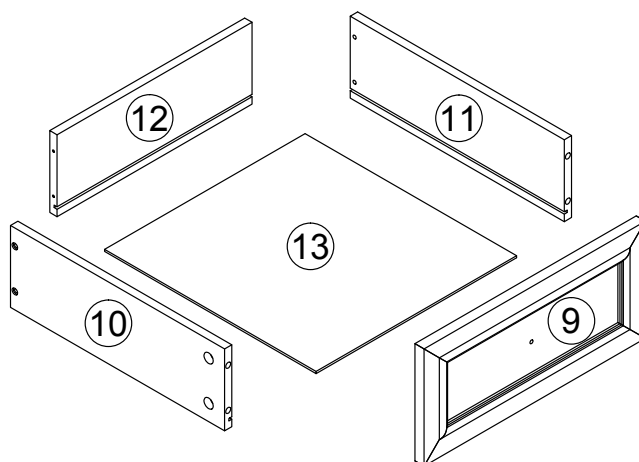
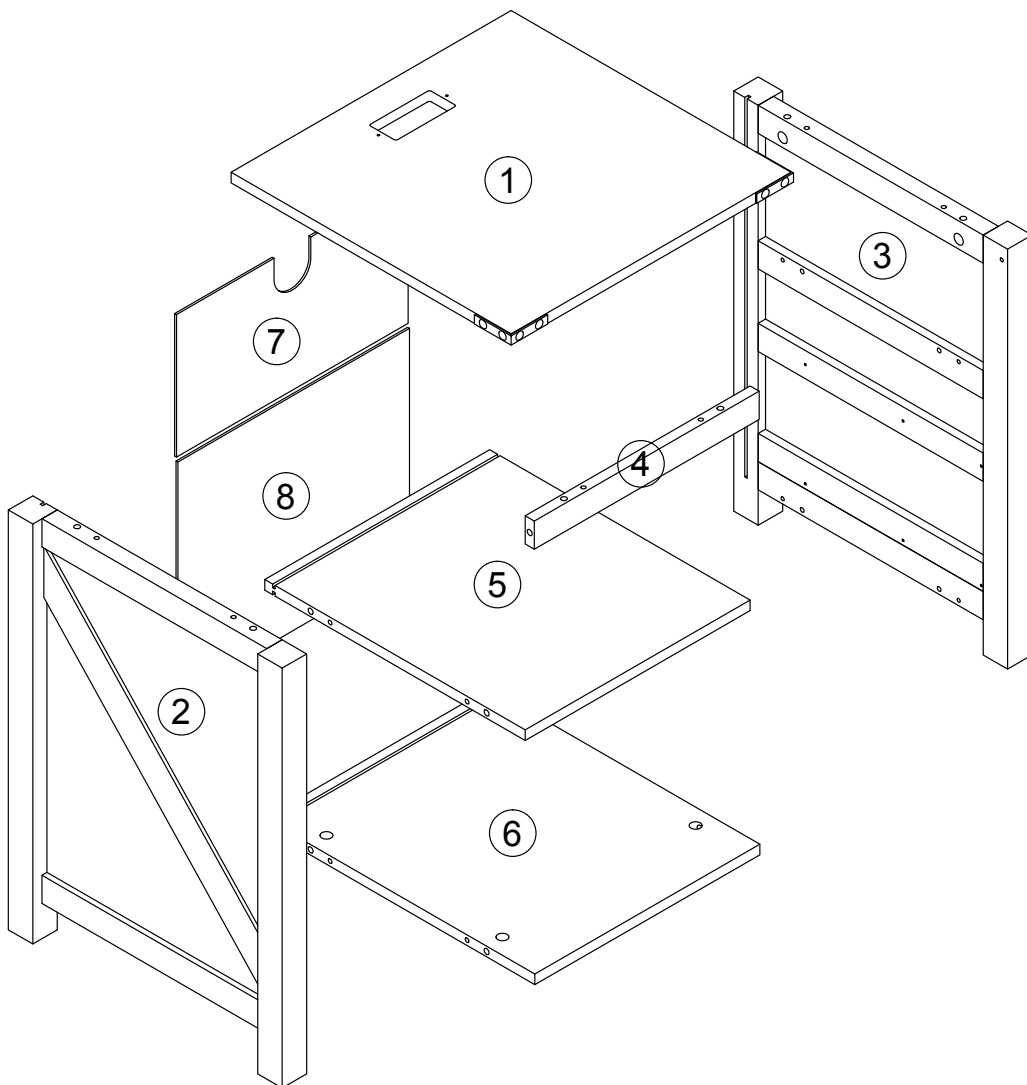







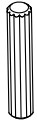

Please check if all the piece listed bellow are received

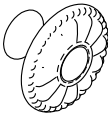

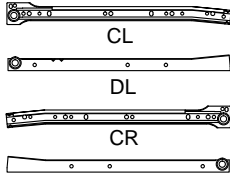
X2

Hardware List

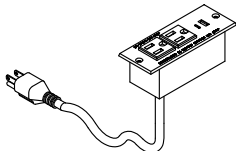
Please check if all the piece listed bellow are received

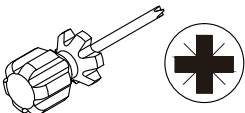
| | | | | |
|---|--|---|---|---|
| <p>A</p>  <p>Wood Dowel Ø6*30mm Qty: 14+1</p> | <p>B</p>  <p>Cam Lock Ø15*10mm Qty: 24+2</p> | <p>C</p>  <p>Cam Bolt Ø6*33mm Qty: 24+2</p> | <p>D</p>  <p>Screw Ø4*35mm Qty: 8+1</p> | <p>E</p>  <p>Handle Qty: 2</p> |
| <p>F</p>  <p>M4*10mm Qty: 2</p> | <p>G</p>  <p>CL DL CR DR Qty: 2</p> | <p>H</p>  <p>Screw Ø3*12mm Qty: 24+2</p> | <p>I</p>  <p>Plastic wedge Qty: 8+1</p> | <p>J</p>  <p>Plat-head screw Ø3*17mm Qty: 8+1</p> |
| <p>K</p>  <p>Charger Station Qty: 1</p> | <p>L</p>  <p>Philips Head Screwdriver Ø3*12mm Qty: 2</p> | <p>M</p>  <p>Qty: 1</p> | | |

Step 1

- I. Using screw (H) secure slide rail CL (G) to Panel (2) with Screwdriver (M) tighten.
- II. Using screw (H) secure slide rail CR (G) to panel(3) with screwdriver (M) tighten.

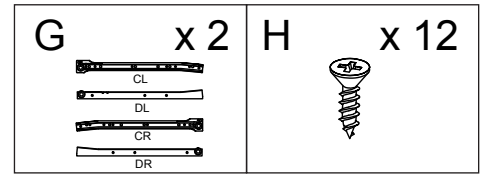

Note: Slide rail needs to distinguish between left and right and direction.

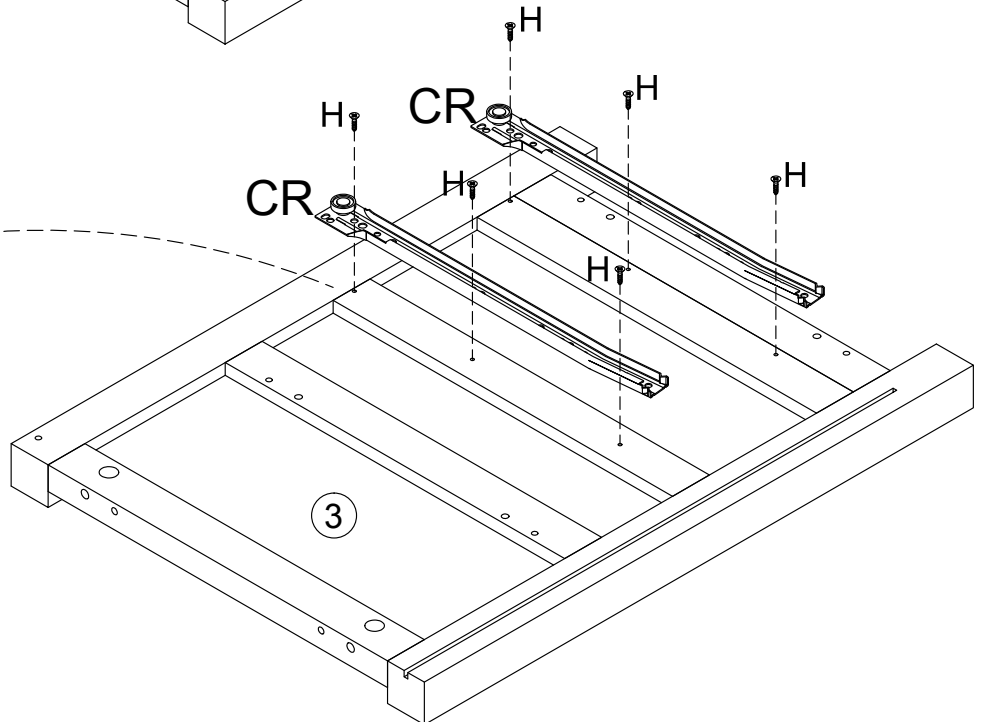
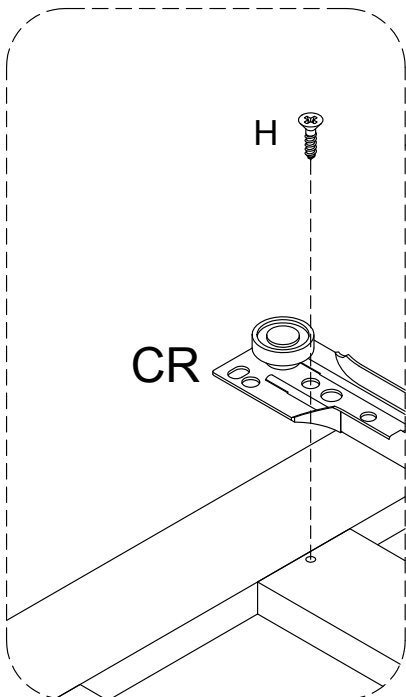
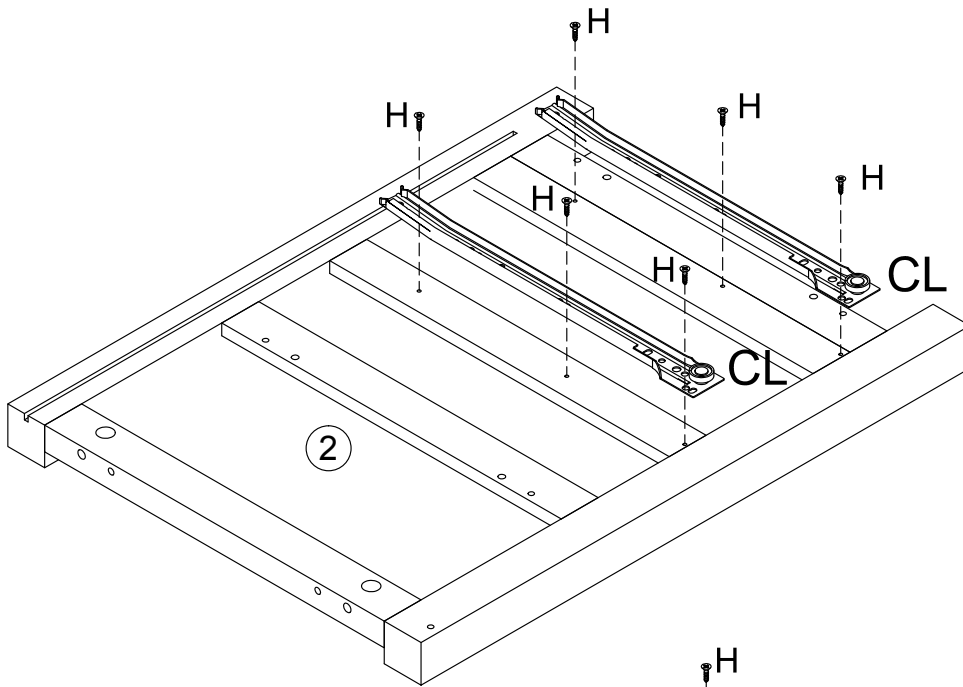
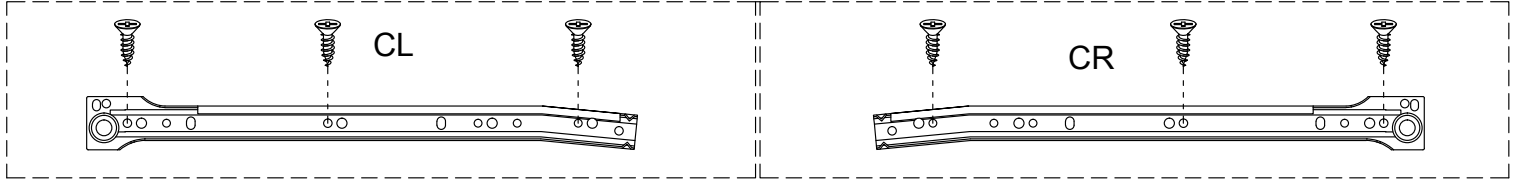

Step 2

I. Secure cam bolt (C) into panel (3) with screwdriver (M) as per diagram.

II. Insert wooden dowel (A) into panel (3) as per diagram.

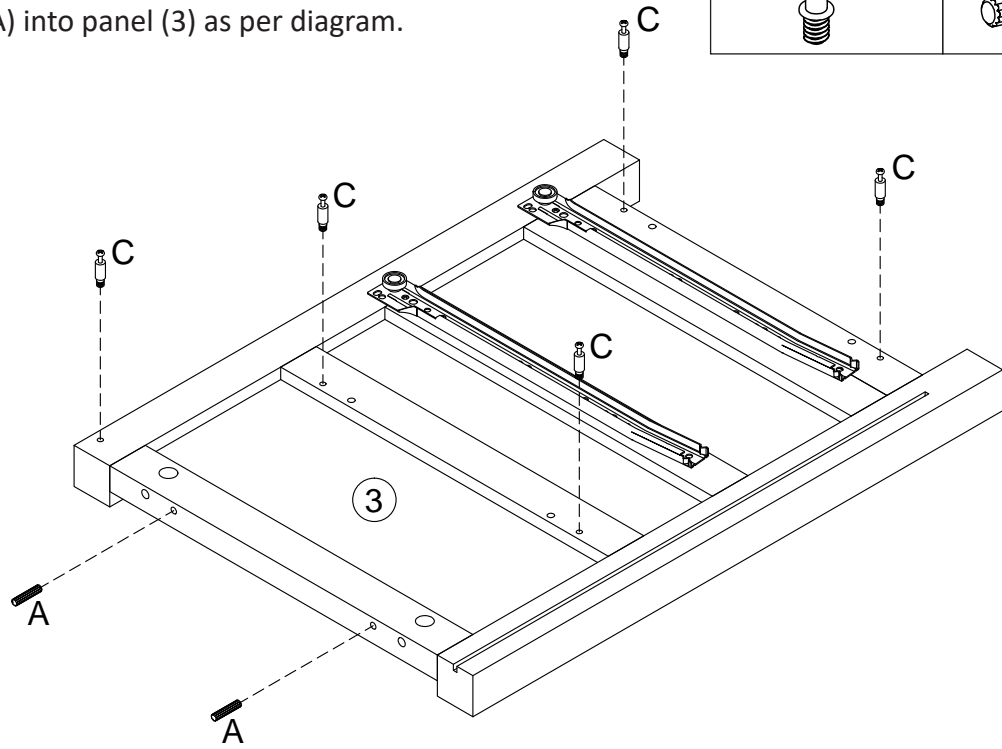
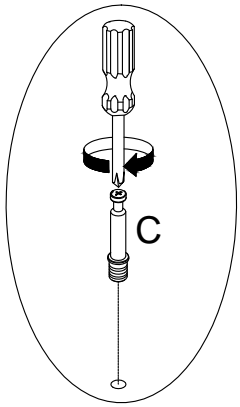
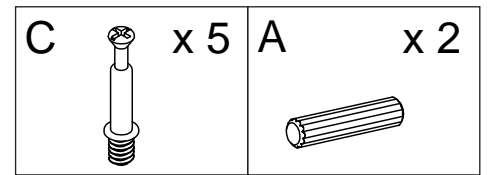

Step 3

I. Insert wooden dowel (A) into panel (6) as per diagram.

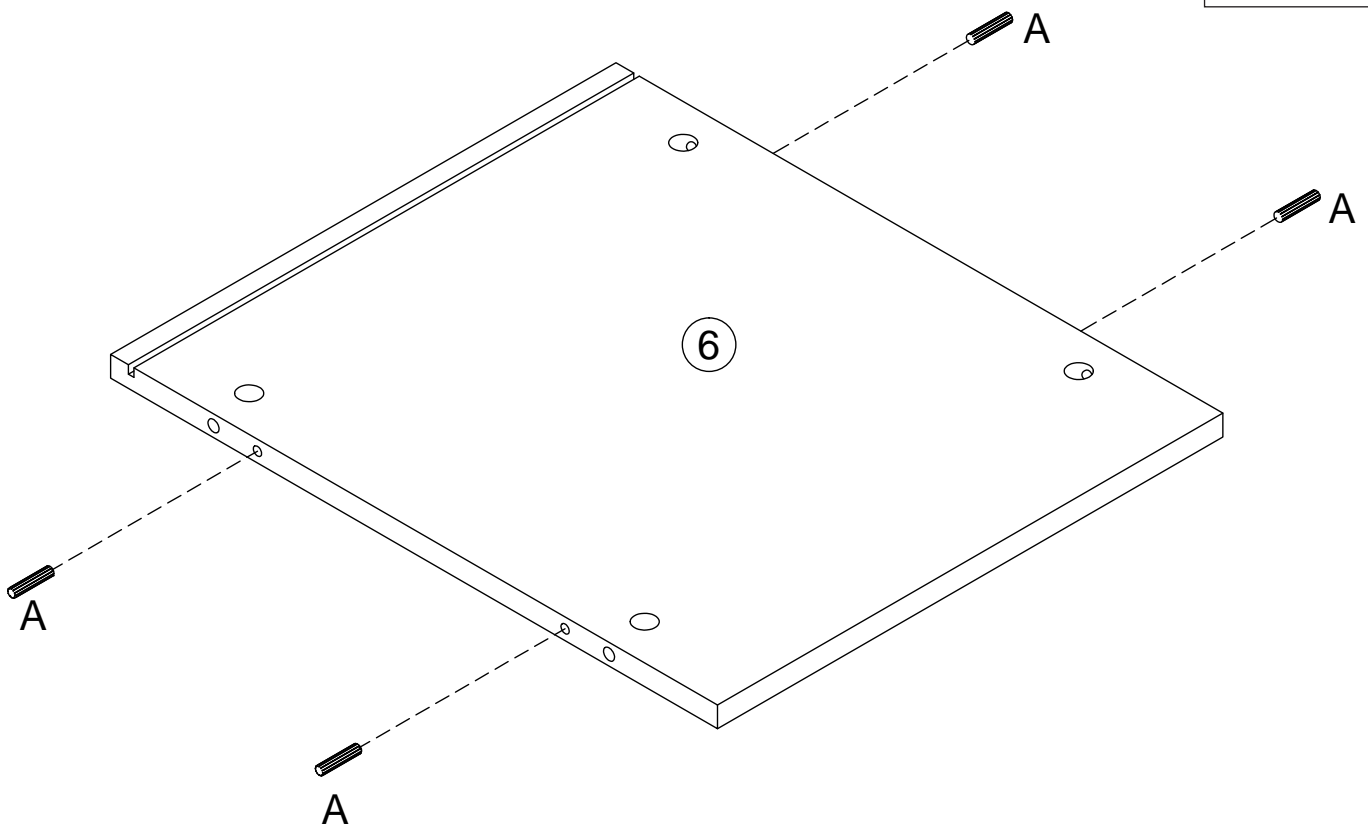
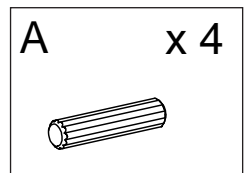

Step 4

I. Insert wooden dowel (A) into panel (5) as per diagram.

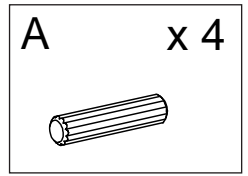
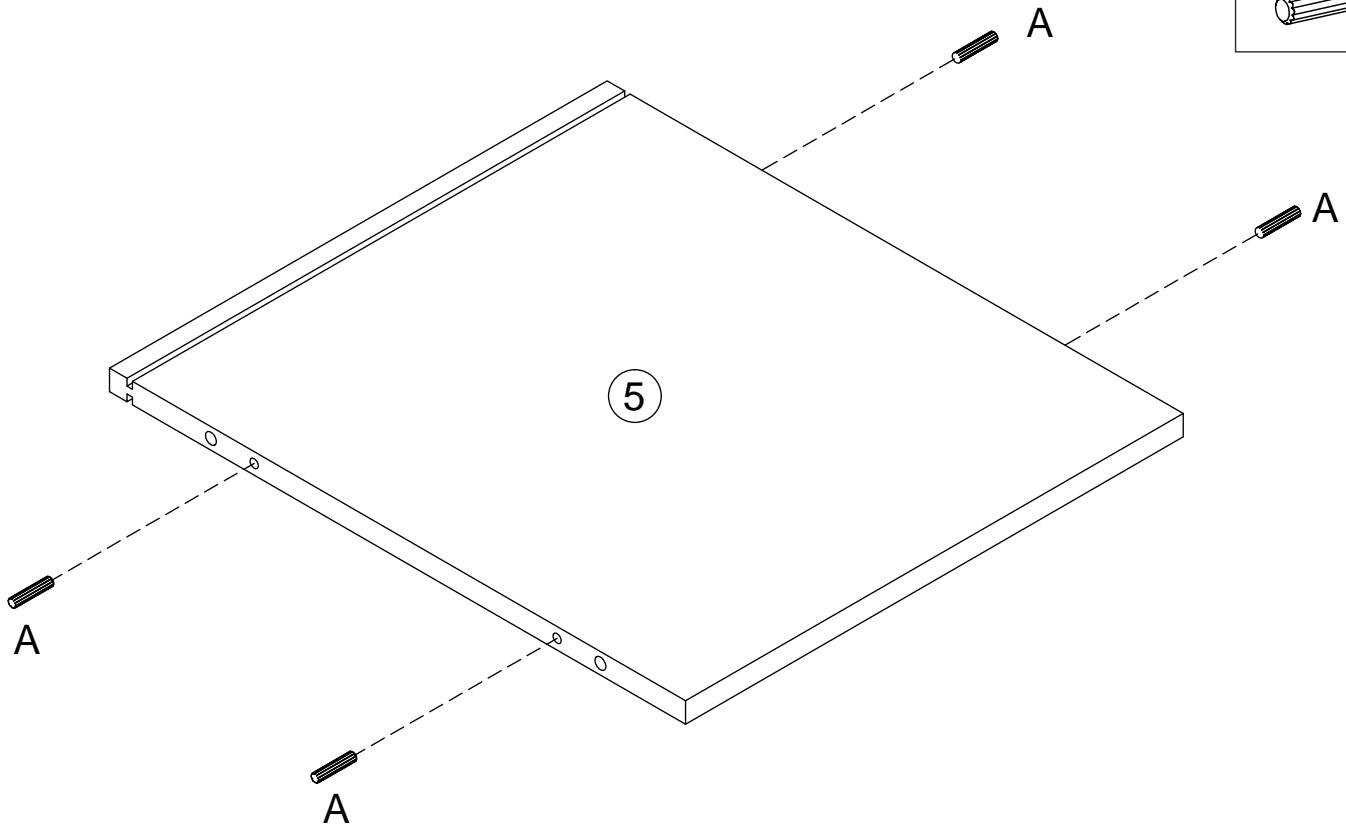

Step 5

I. Insert wooden dowel (A) into panel (4) as per diagram.

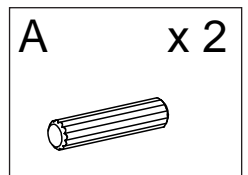
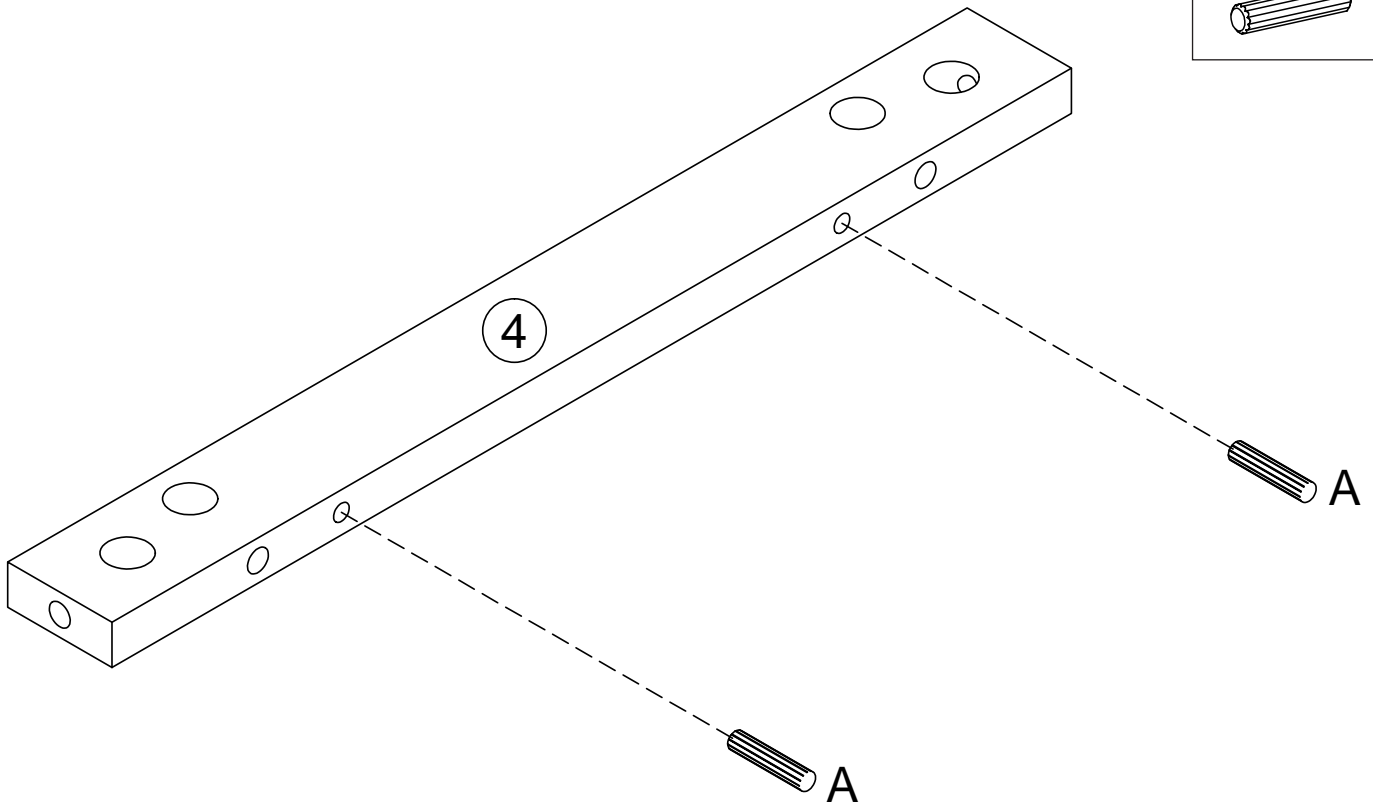

Step 6

I. Attach (6) to panel (3), insert cam-lock (B) into the holes on Panel (6), then turn clockwise to lock onto cam-bolt.

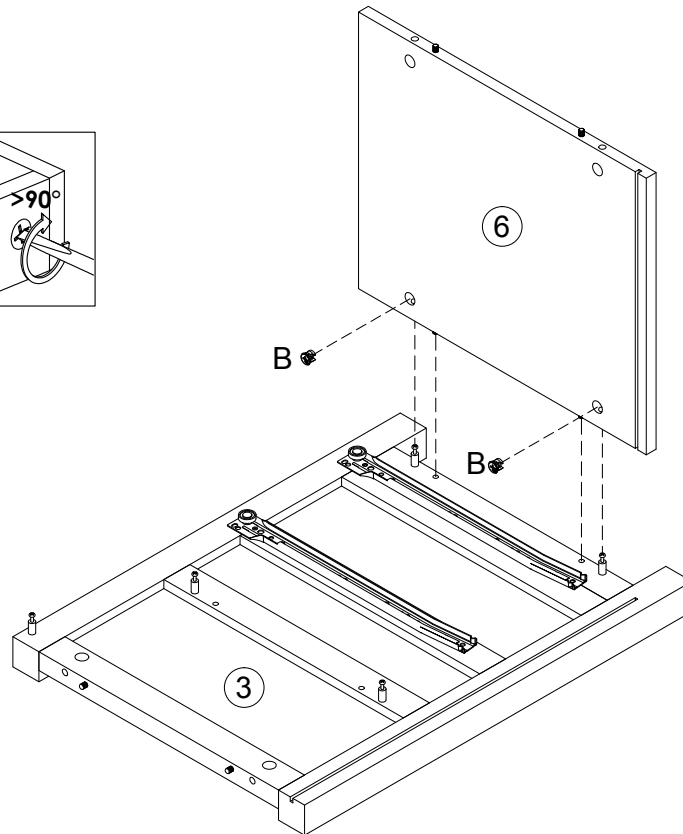
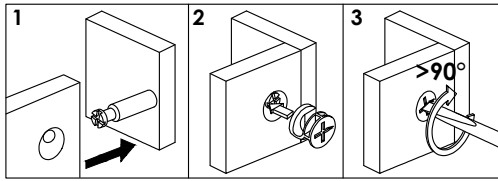
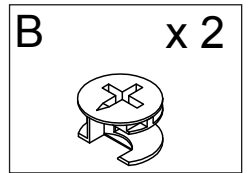

Step 7

I. Attach panel (5) to panel (3), insert cam-lock (B) into the holes on Panel (5), then turn clockwise to lock onto Cam-bolt.

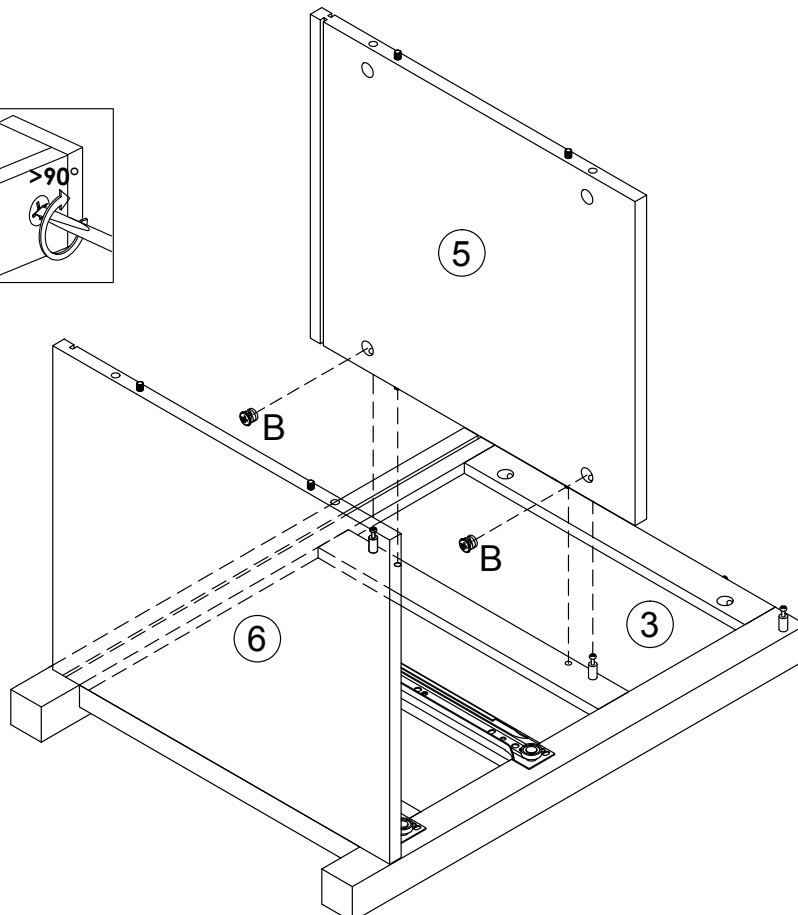
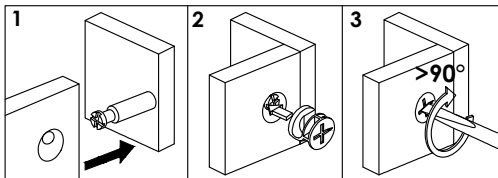
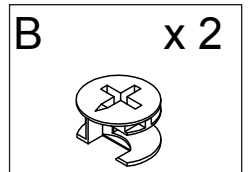

Step 8

I. Place panel(8) as per diagram.

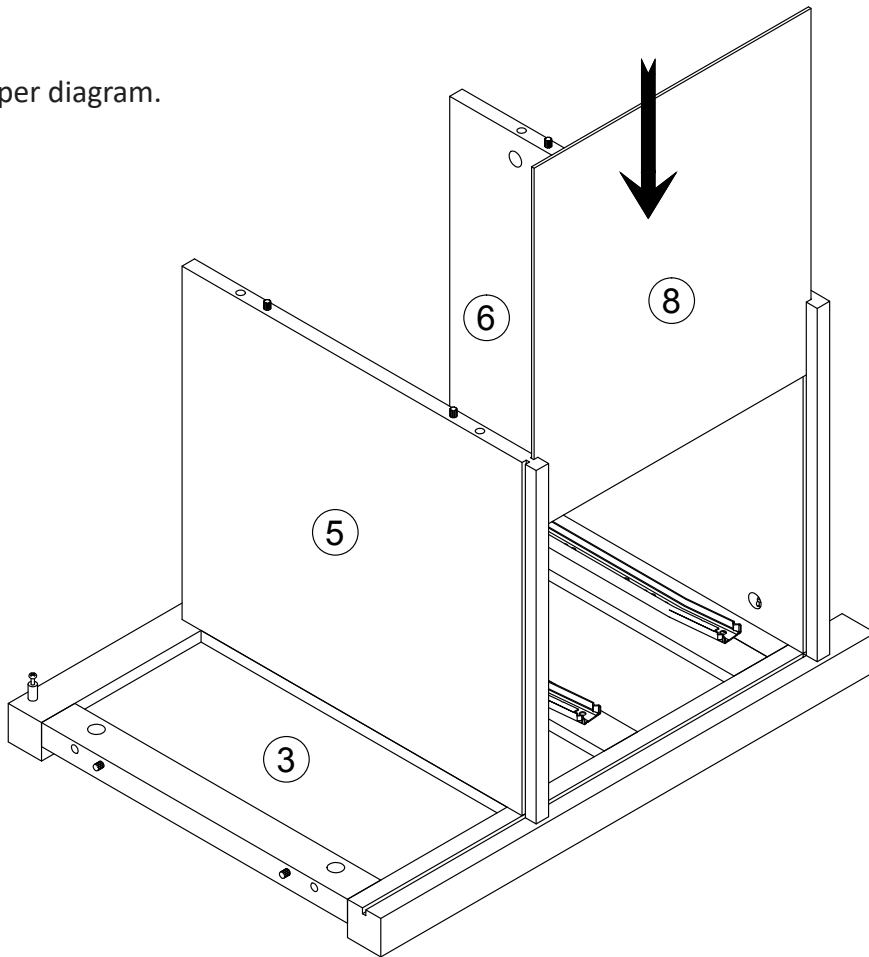

Step 9

I. Attach (4) to panel (3), insert cam-lock (B) into the holes on panel (4), then turn clockwise to lock onto Cam-bolt.

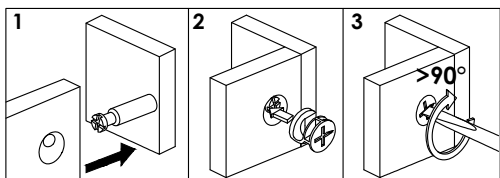
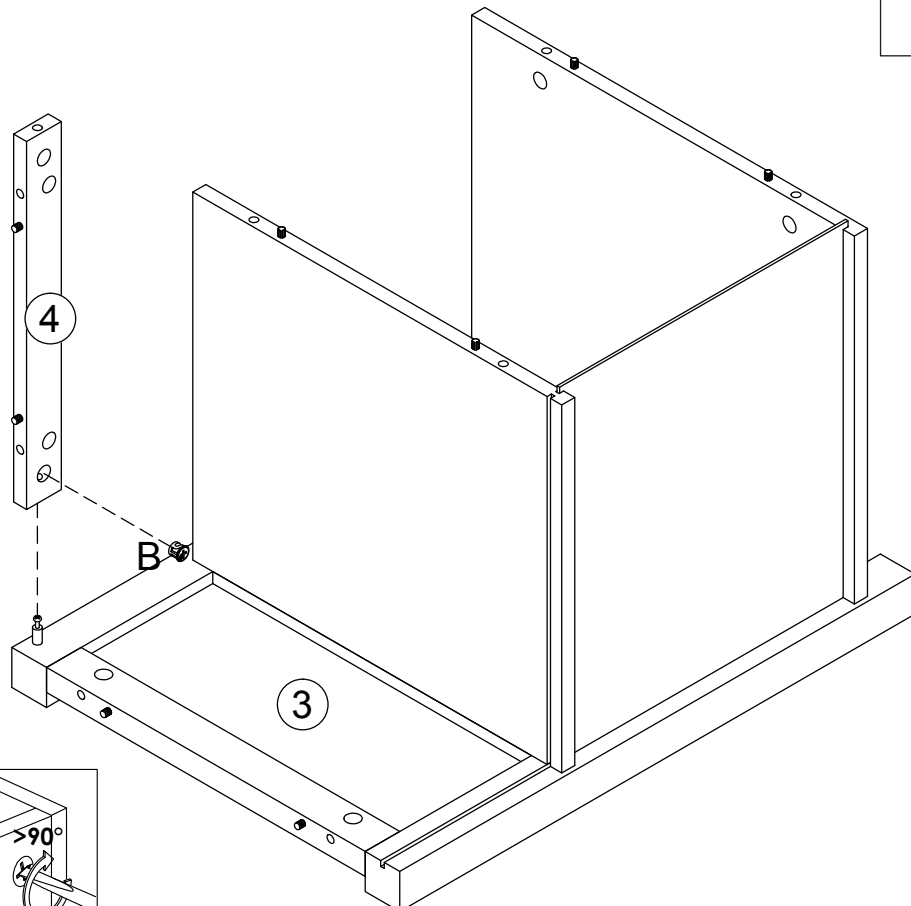
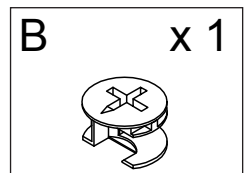

Step 10

I. Secure cam bolt (C) into panel (2) with screwdriver (M) as per diagram.

II. Insert wooden dowel (A) into panel (2) as per diagram.

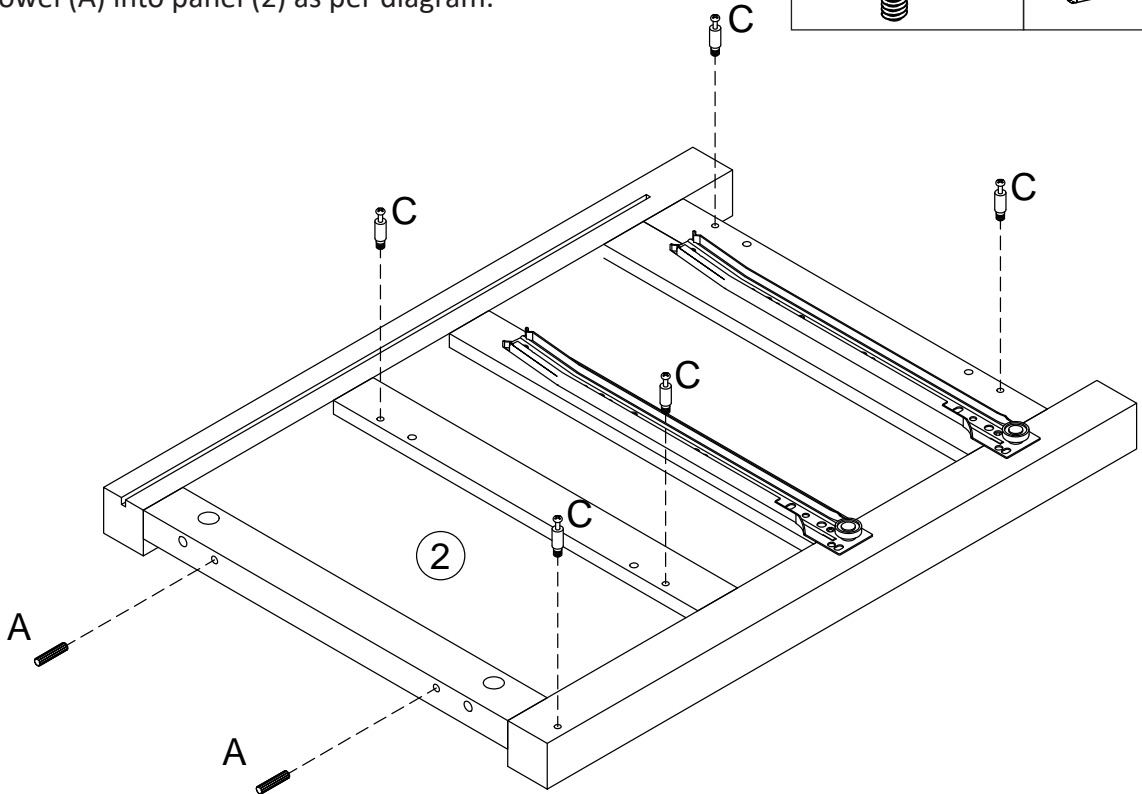
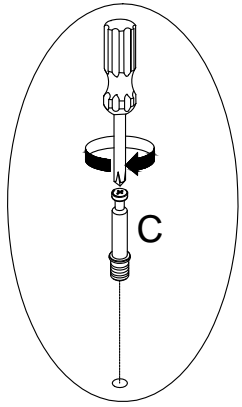
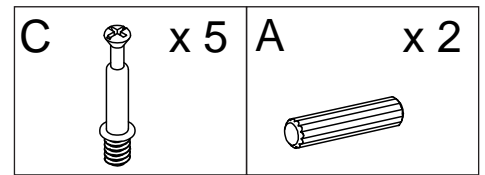

Step 11

I. Attach panel (2) to frame, insert cam-lock (B) into the designated holes, then turn clockwise to lock onto Cam-bolt.

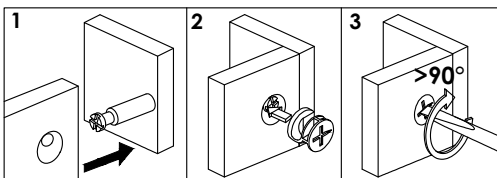
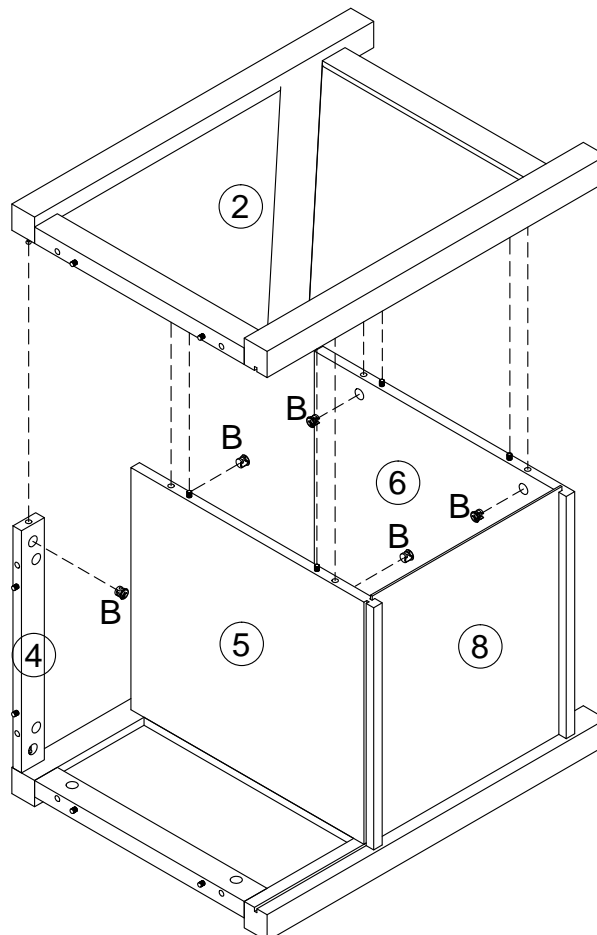
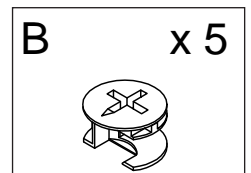

Step 12

I. Place panel (7) as per diagram.

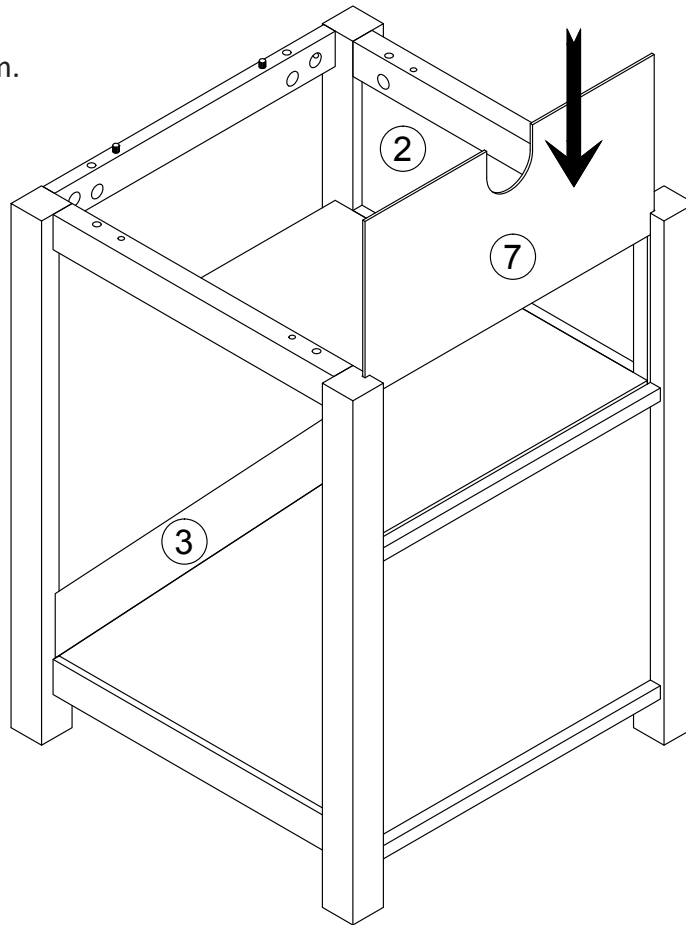

Step 13

I. Secure cam bolt (C) into panel (1) with screwdriver (M) as per diagram.

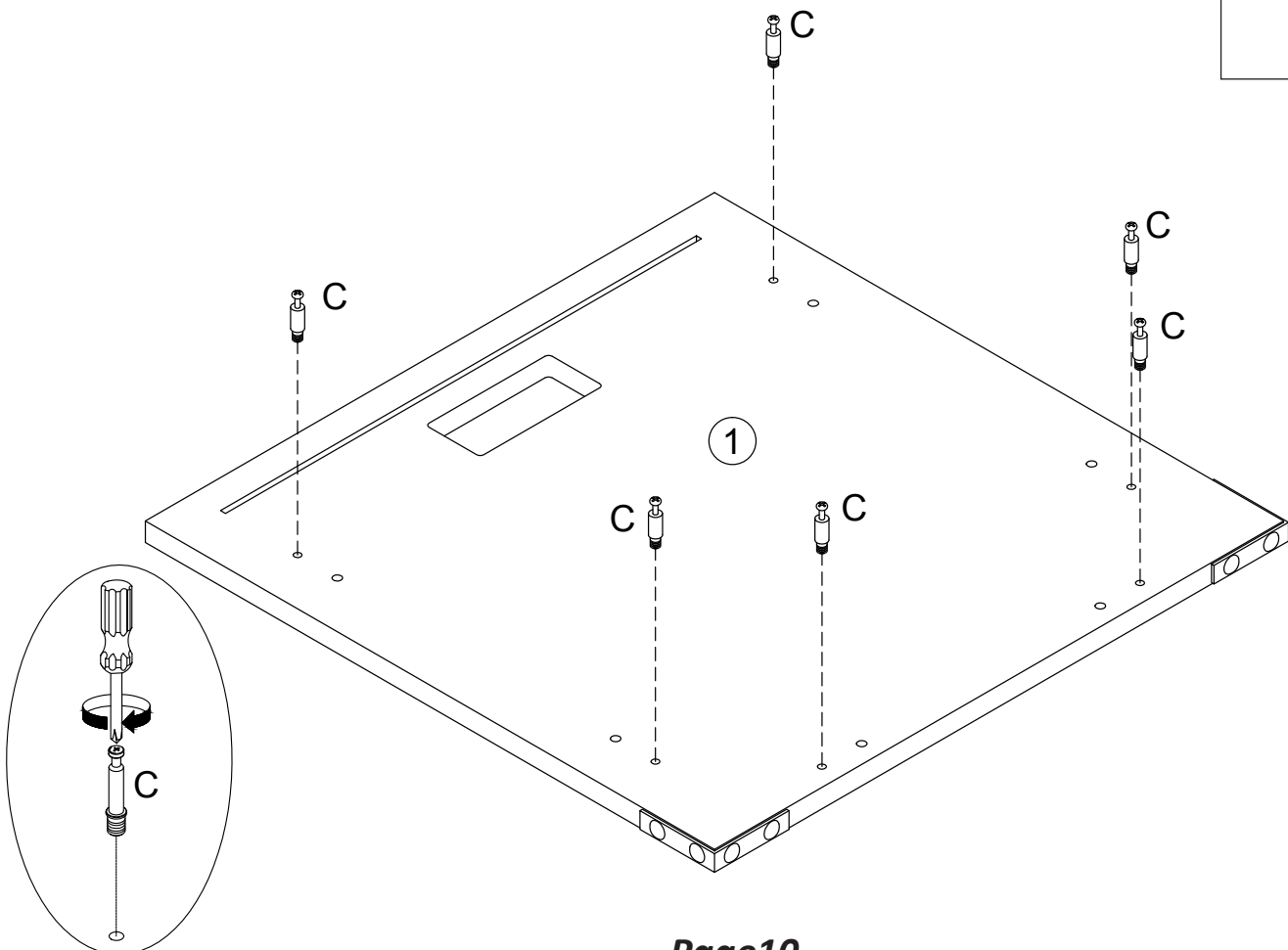
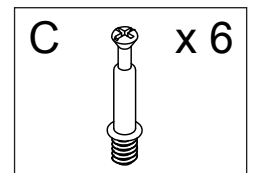

Step 14

I. Attach panel(1) to frame, insert cam-lock (B) into the designated holes, then turn clockwise to lock onto cam-bolt.

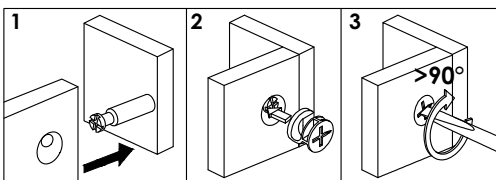
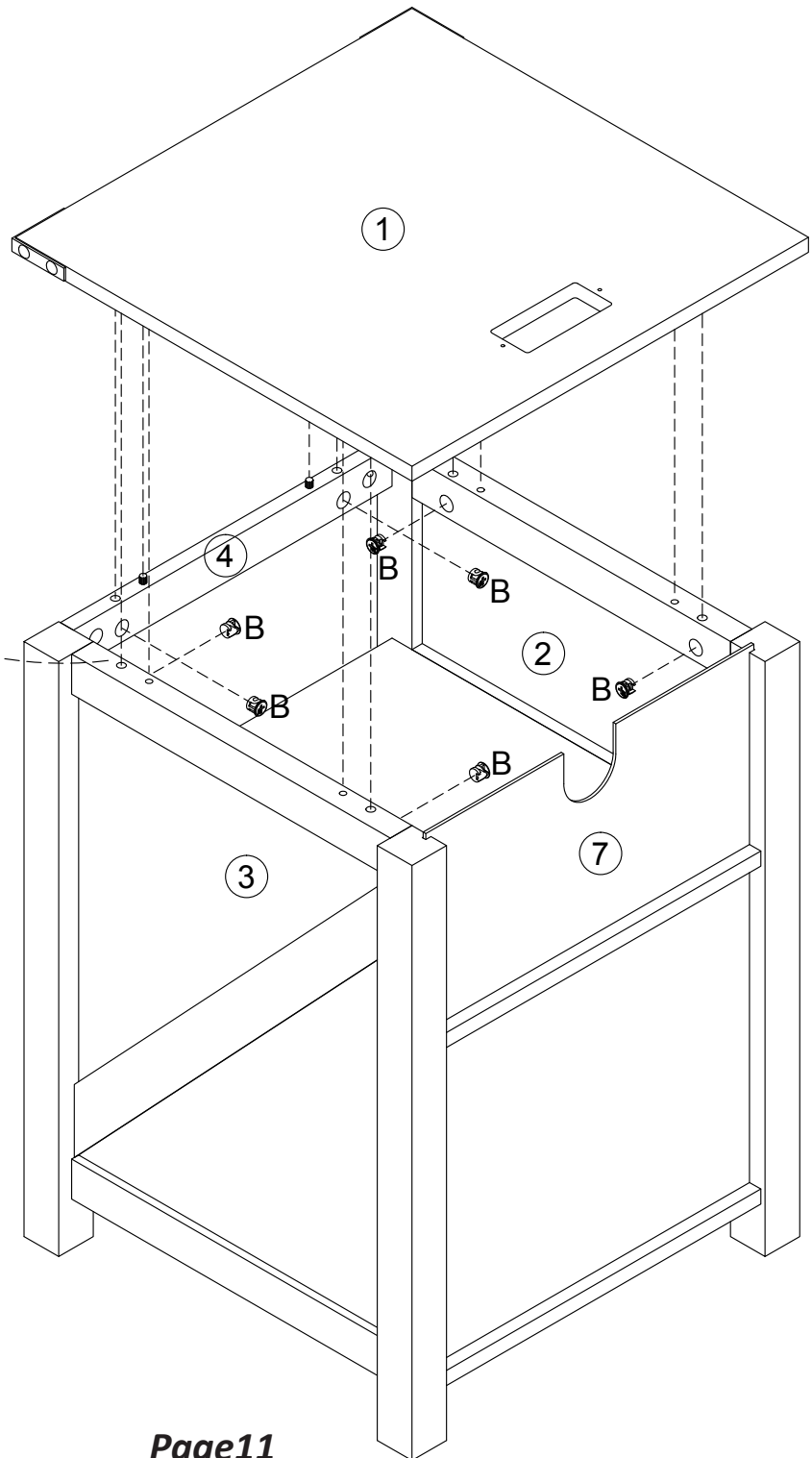
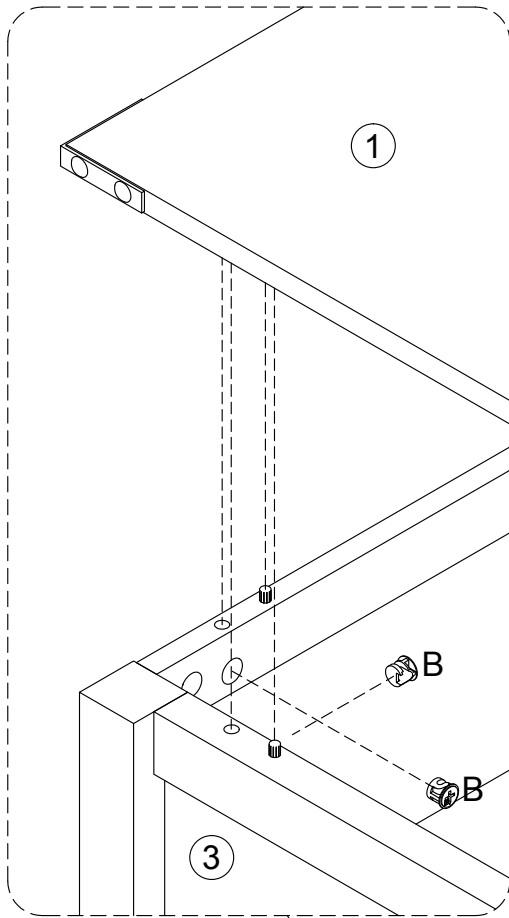
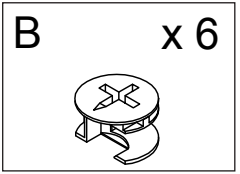

Step 15

I. Secure cam bolt(C) into panel(9) with screwdriver (M) as per diagram.

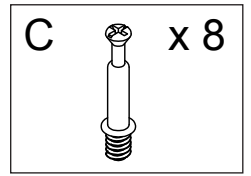
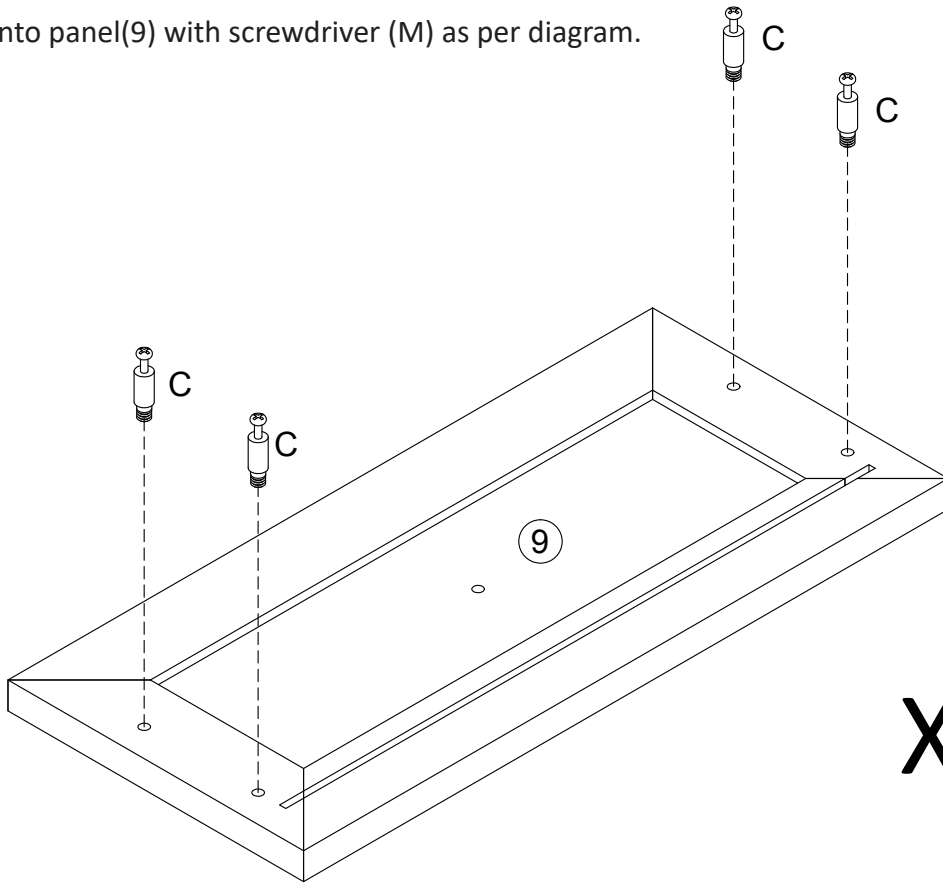
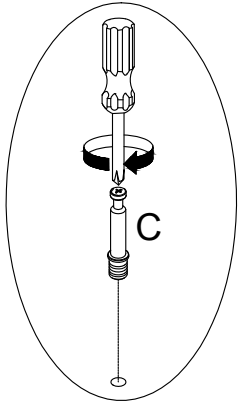

X2

Step 16

I. Use panel(9)cam-bolts attach panel (10,11),insert cam-lock (B) into the designated holes,then turn clockwise to lock onto cam-bolt.

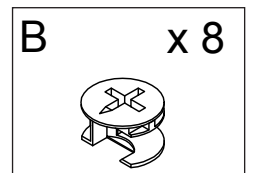
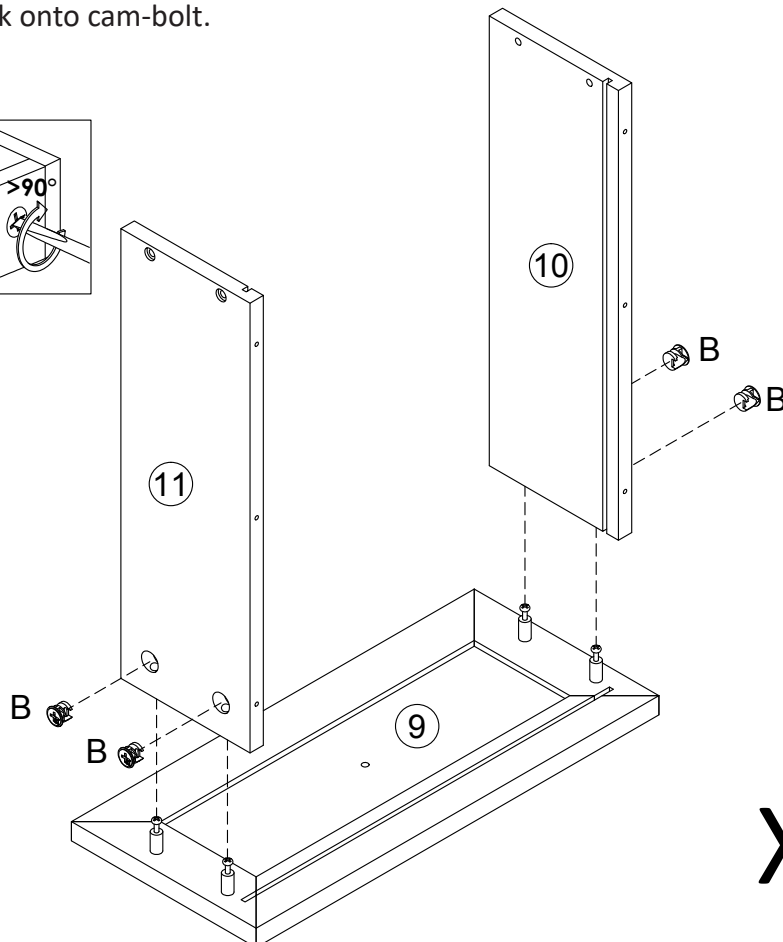
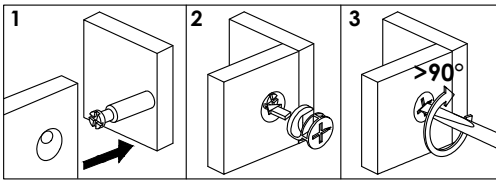

X2

Step 19

I. Using screw (H) secure slide rail DR (G) to panel (11) with Screwdriver (M) tighten.

II. Using screw (H) secure slide rail DL (G) to panel (10) with screwdriver (M) tighten.

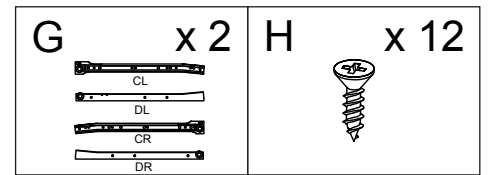

Note: Slide rail needs to distinguish between left and right and direction.

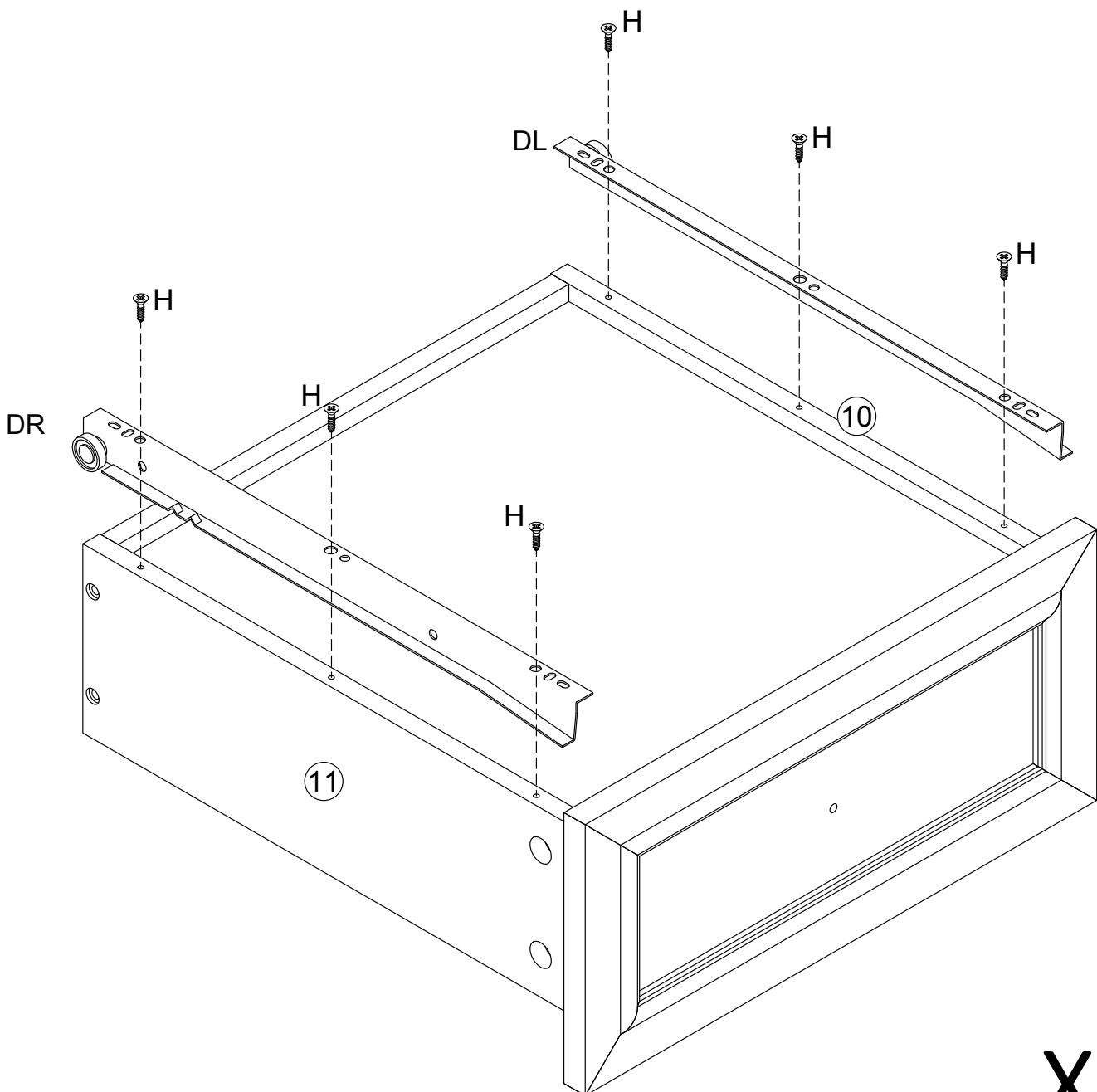
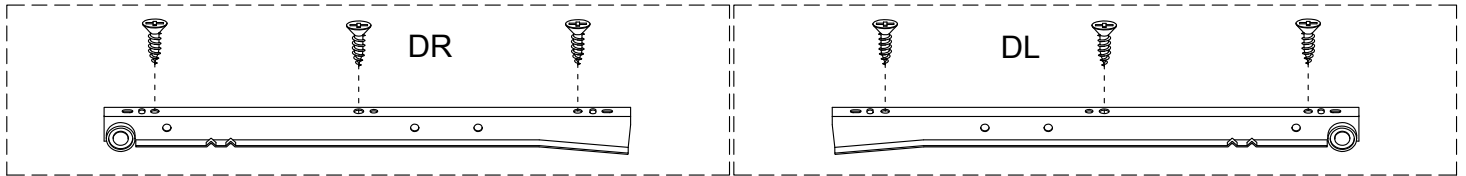

X2

Step 20

I. Using screw (F) secure handle (E) to panel (9) with Screwdriver as per diagram.

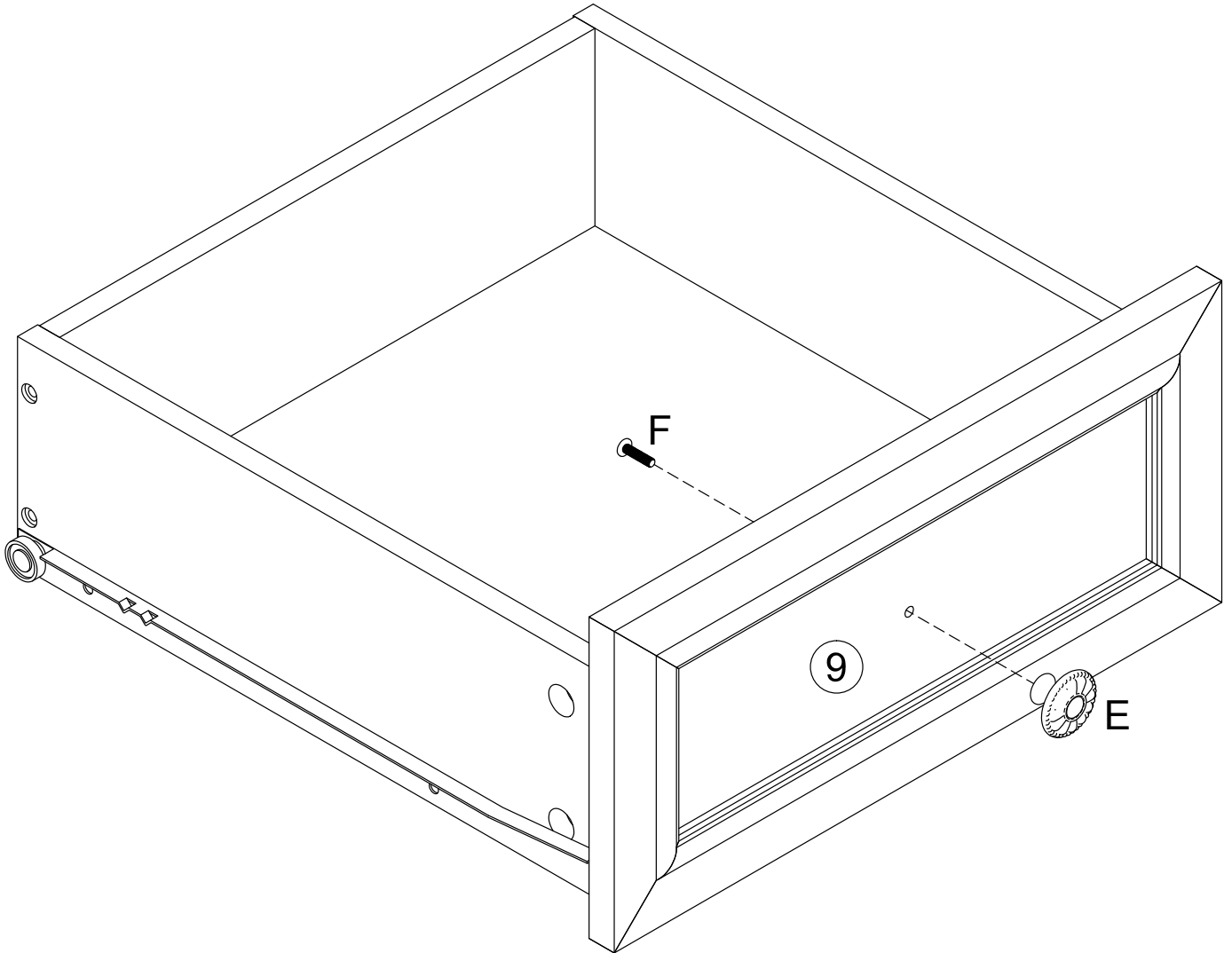
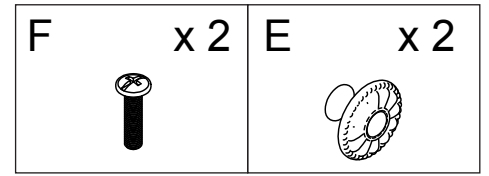

X2

Step 21

I. Place drawer as per diagram.

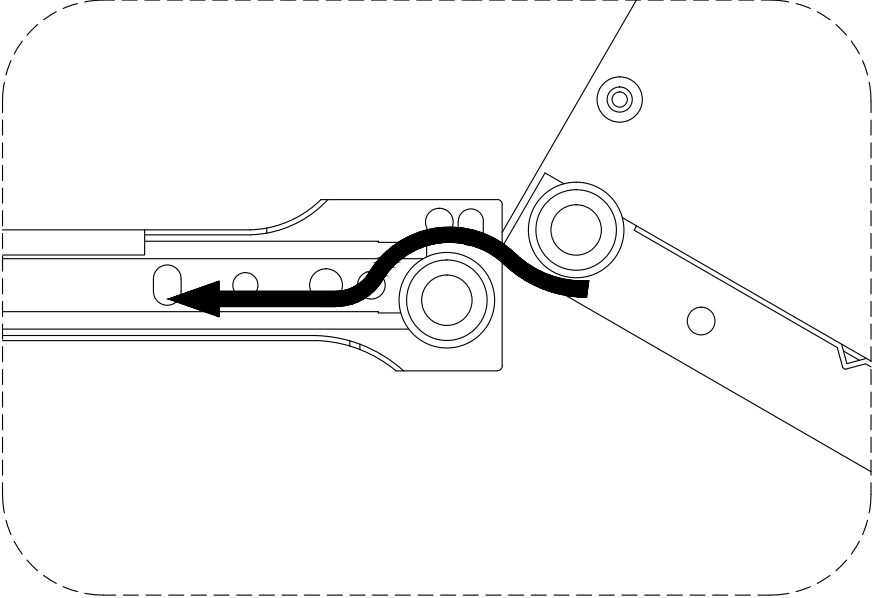
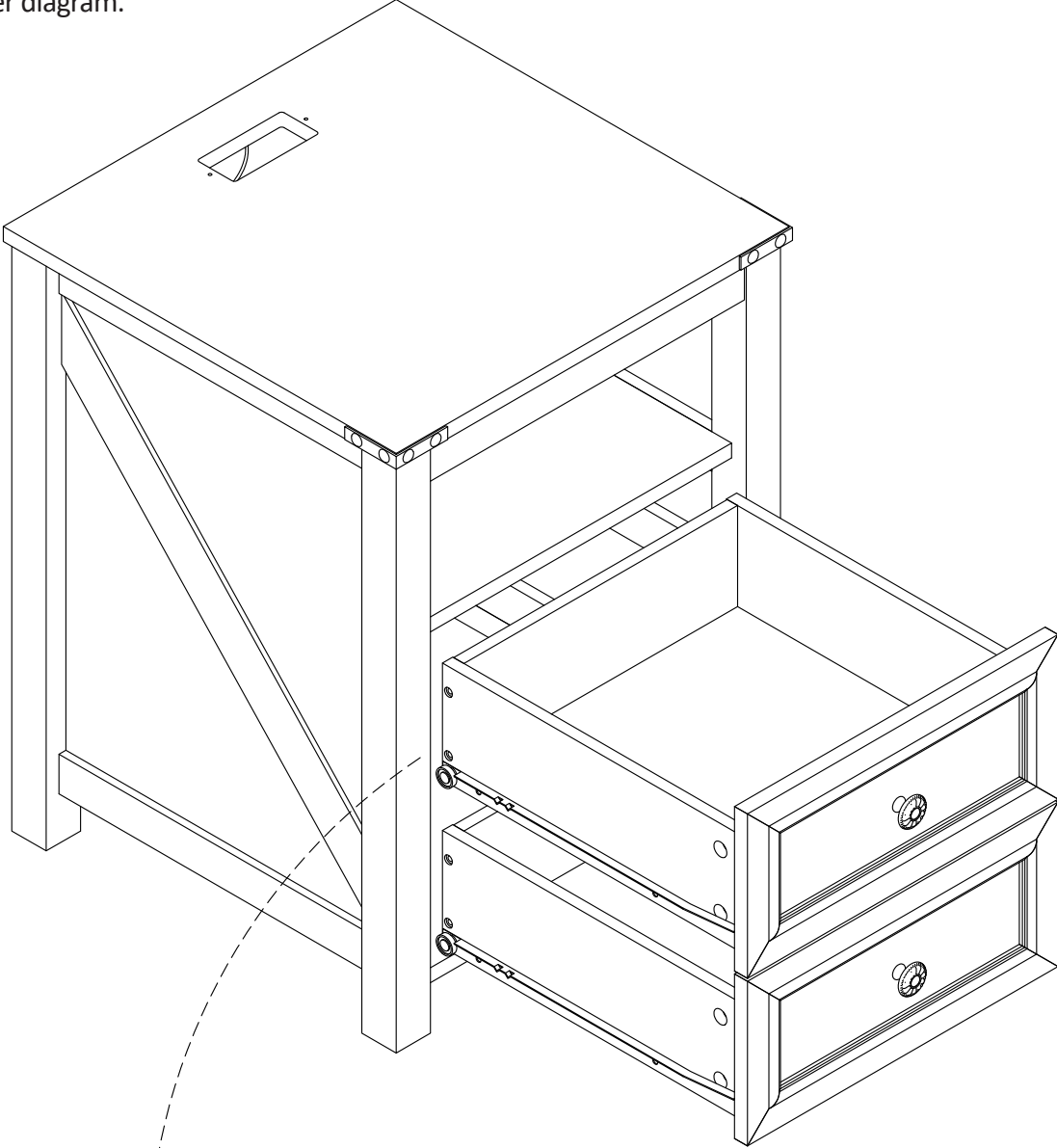

Step 22

I. Using screw (J) attach plastic wedge (I) to panel (7,8) with screwdriver as per diagram.

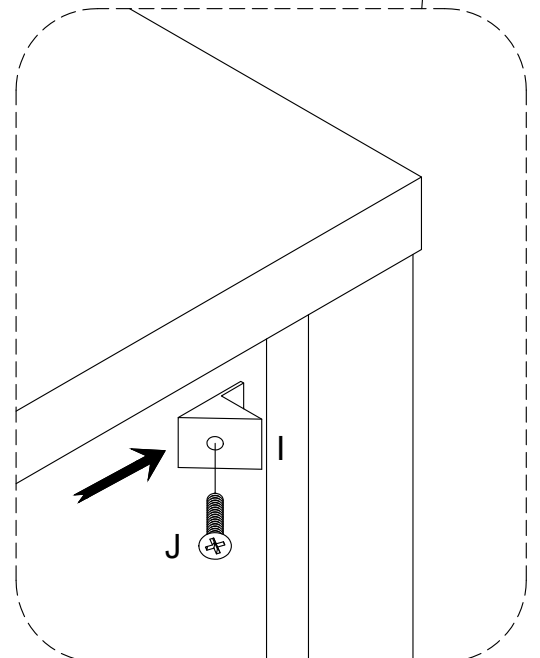
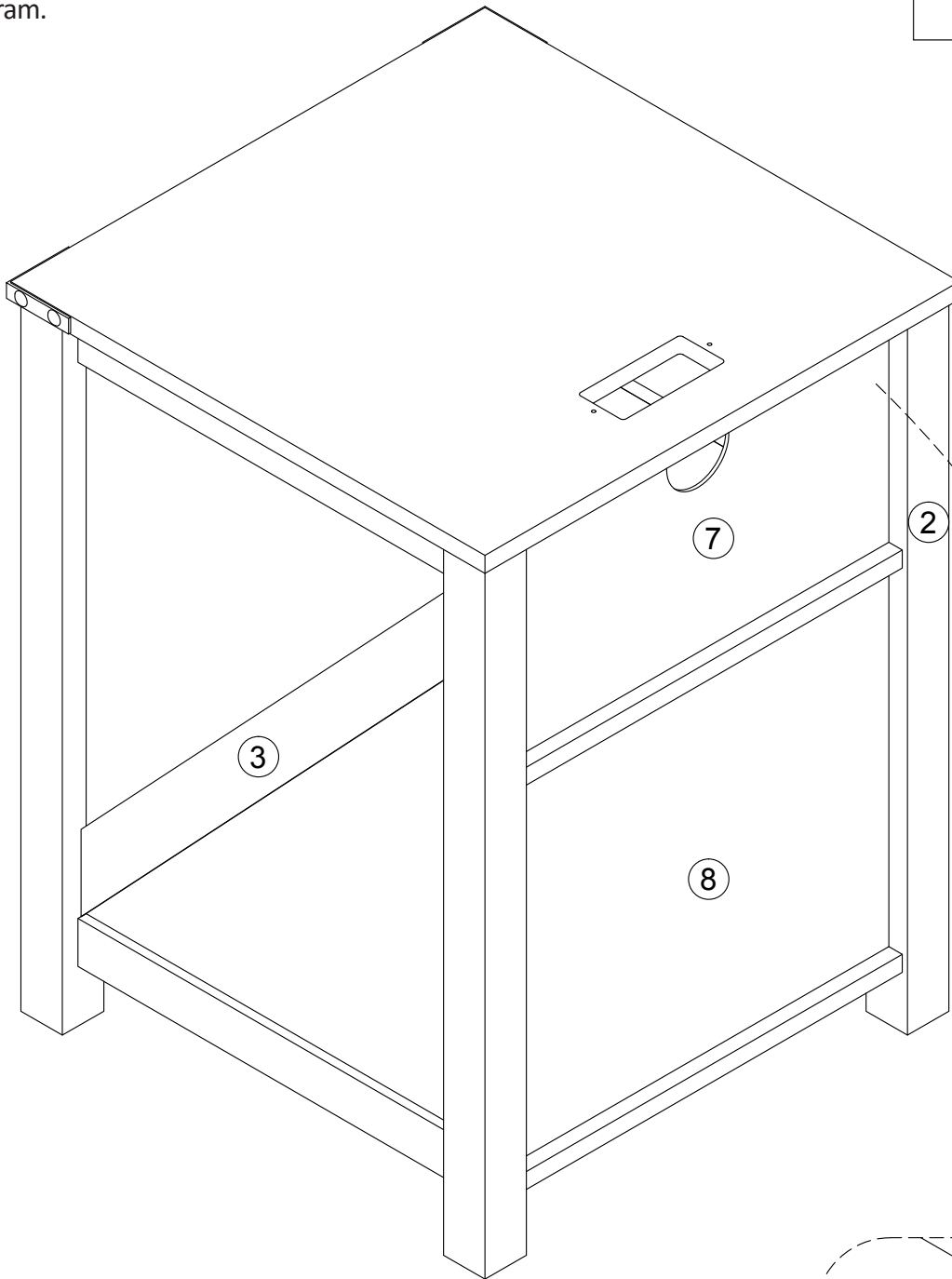
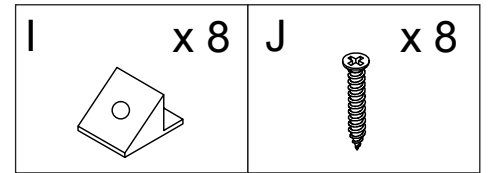

Step 23

I. Useing screw(H)secure charger station(L)to panel(1)with screwdriver as per diagram.

