

FR INSTRUCTION D' INSTALLATION
DE MONTAGEANWEISUNG
EN ASSEMBLY MANUAL
PL INSTRUKCJA MONTAŻU

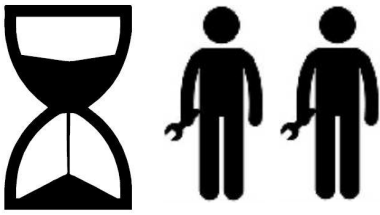

~80 min

FR Outils nécessaires au montage (ne sont pas livrés par le producteur).
DE Für die Montage benötigen Sie folgende (nicht vom Hersteller bereitgestellt) :
EN Tools necessary for assembly (not supplied by the manufacturer) :
PL Narzędzia potrzebne do montażu (nie są dostarczane przez producenta) :

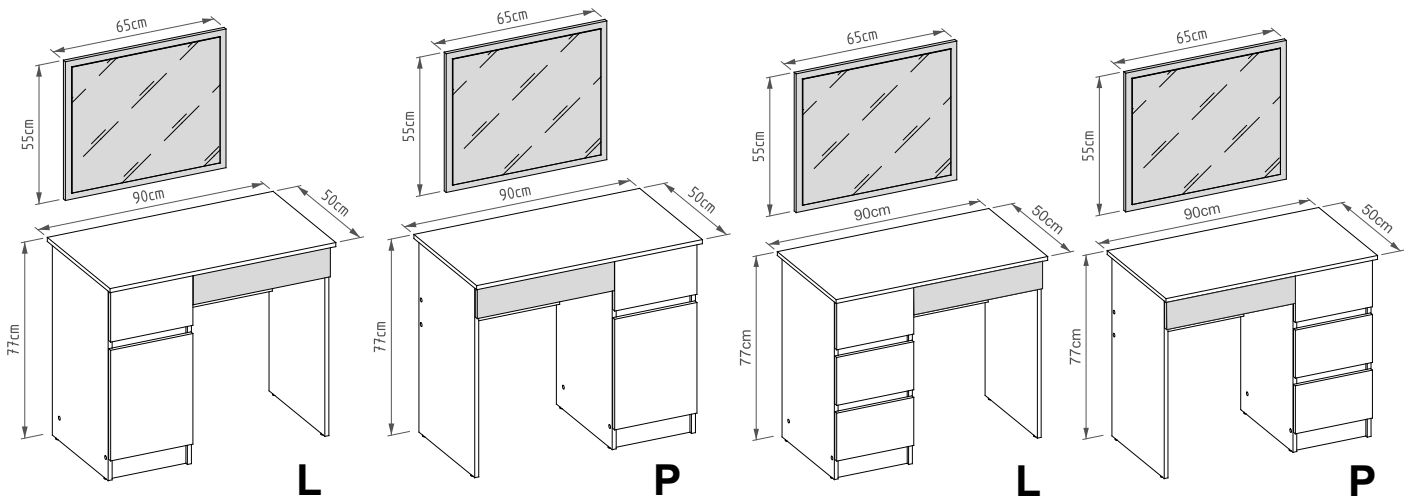
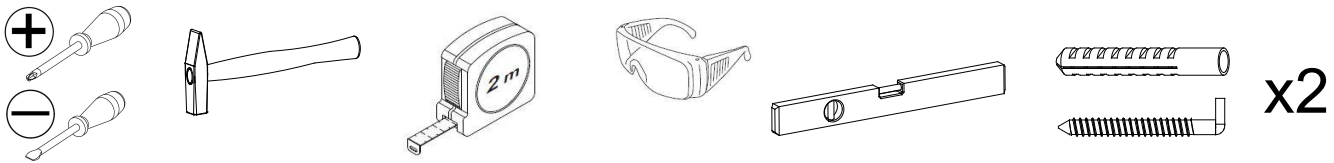

FR: INFORMATIONS IMPORTANTES!

Avant d' utiliser le produit lisez attentivement les consignes de sécurité.

Veuillez lire attentivement les instructions d' utilisation et les conserver pour référence future.

DE: WICHTIGE INFORMATIONEN!

Lesen Sie die Sicherheitshinweise Sorgfältig durch, bevor Sie das Produkt verwenden.
Bitte Lesen Sie die Bedienungsanleitung und speichern Sie es für die zukünftige Verwendung.

EN: IMPORTANT INFORMATION!

Please read the entire manual carefully before starting to assemble and/or using this product. Follow the manual thoroughly and keep it for further reference.

PL: WAŻNE INFORMACJE!

Przed użyciem produktu należy dokładnie zapoznać się ze wskazówkami bezpieczeństwa. Należy zapoznać się z instrukcją obsługi i zachować ją do użytku w przyszłości.

FR ATTENTION!

Ne pas installer d'éléments endommagés. En cas de réclamation veuillez nous informer du problème par e-mail reklamacje@akord.net.pl Notre employé vous contactera pour résoudre le problème dans les plus brefs délais. Si possible veuillez marquer les éléments endommagés ou manquants sur les instructions et les envoyer avec application.

DE ACHTUNG!

Wir installieren keine beschädigten Elemente! Im Falle einer Beschwerde teilen Sie uns dies bitte unter mit das Thema des Problems an die E-Mail reklamacje@akord.net.pl Unser Mitarbeiter wird sich mit Ihnen in Verbindung setzen, um das Problem so schnell wie möglich zu lösen, wenn es möglich ist. Bitte markieren Sie die beschädigten oder fehlenden Elemente in der Anleitung und senden Sie zusammen mit der Anwendung.

EN ATTENTION!

Do not install damaged components! In the event of a complaint, please let us know at the subject of the problem to the e-mail reklamacje@akord.net.pl . Our employee will contact you to solve the problem as soon as possible. Please mark the damaged or missing elements on the assembly manual and send them together with the application.

PL UWAGA!

Uszkodzonych elementów nie montujemy! W razie reklamacji prosimy o informację na temat zaistniałego problemu na e-maila reklamacje@akord.net.pl Nasz pracownik skontaktuje się z Państwem aby jak najszybciej rozwiązać problem. Jeśli to możliwe prosimy zaznaczyć na instrukcji uszkodzone lub brakujące elementy i wysłać łącznie z zgłoszeniem

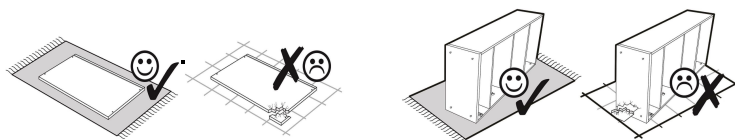

FR AVERTISSEMENT CONTRE LES ENDOMAGEMENTS!

Pour éviter les fissures ce meuble devrait être installé sur un sol mou p.ex. tapis.

DE WARNUNG, UM KRATZER ZU VERMEIDEN!

Um Kratzer zu vermeiden, sollte dieses Möbelstück auf einer weichen Basis wie einem Teppich montiert, gefaltet werden.

EN WARNING TO AVOID SCRATCHES!

In order to avoid scratching this furniture should be assembled on a soft layer - could be a rug.

PL OSTRZEŻENIE WS. USZKODZEŃ!

Aby uniknąć rys, ten mebel powinien być montowany, składany na miękkim podłożu, np. dywanie

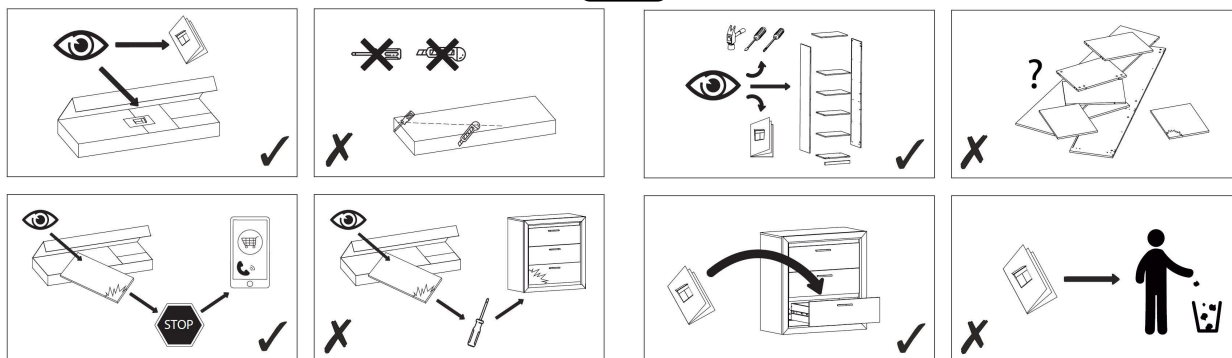

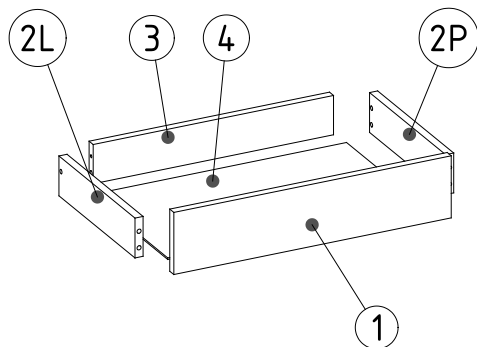
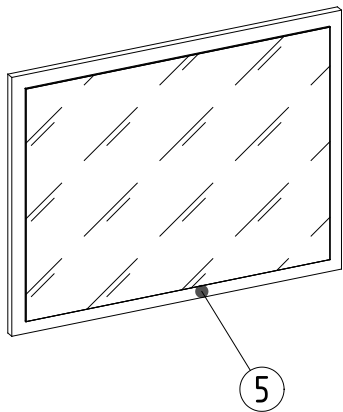

PARTIE/TEIL/PART/LP	TAILLE/GROSSE/SIZE/WYMIAR	NOM./ANZ./QTY./IL.
1	547x120x16mm	1
2L	300x77x16mm	1
2P	300x77x16mm	1
3	474x76x16mm	1
4	305x505x3mm	1
5	650x550x16mm	1

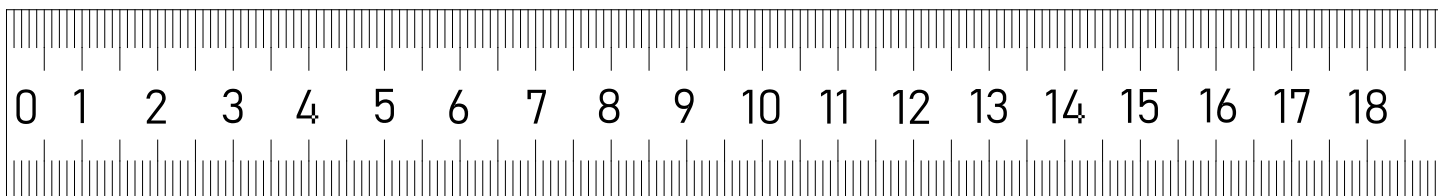
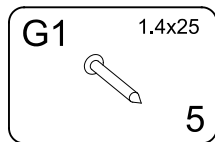
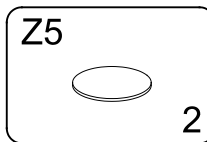
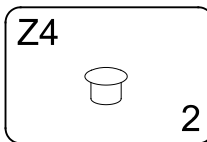
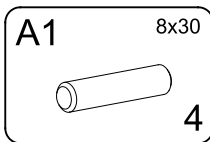
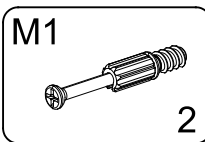
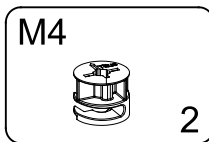
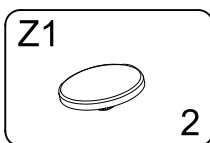
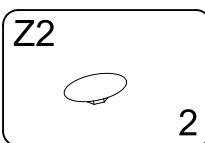
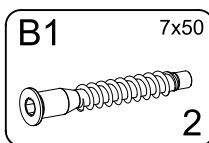

▶ 1

FR Nécessaire au montage:
 DE Sie benötigen für die Montage:
 EN You need for fitting-up:
 PL Niezbędne do montażu:

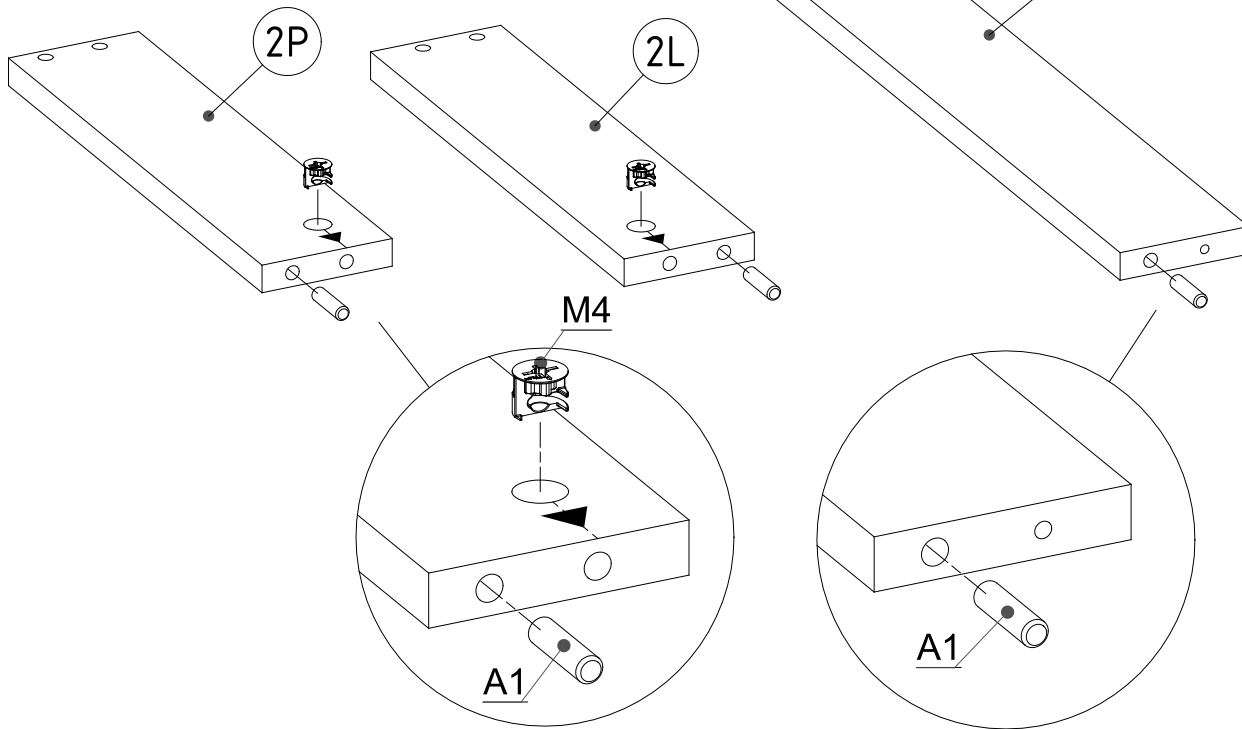
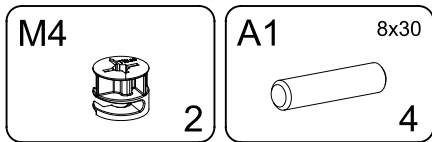

▶ 2

FR Nécessaire au montage:
 DE Sie benötigen für die Montage:
 EN You need for fitting-up:
 PL Niezbędne do montażu:

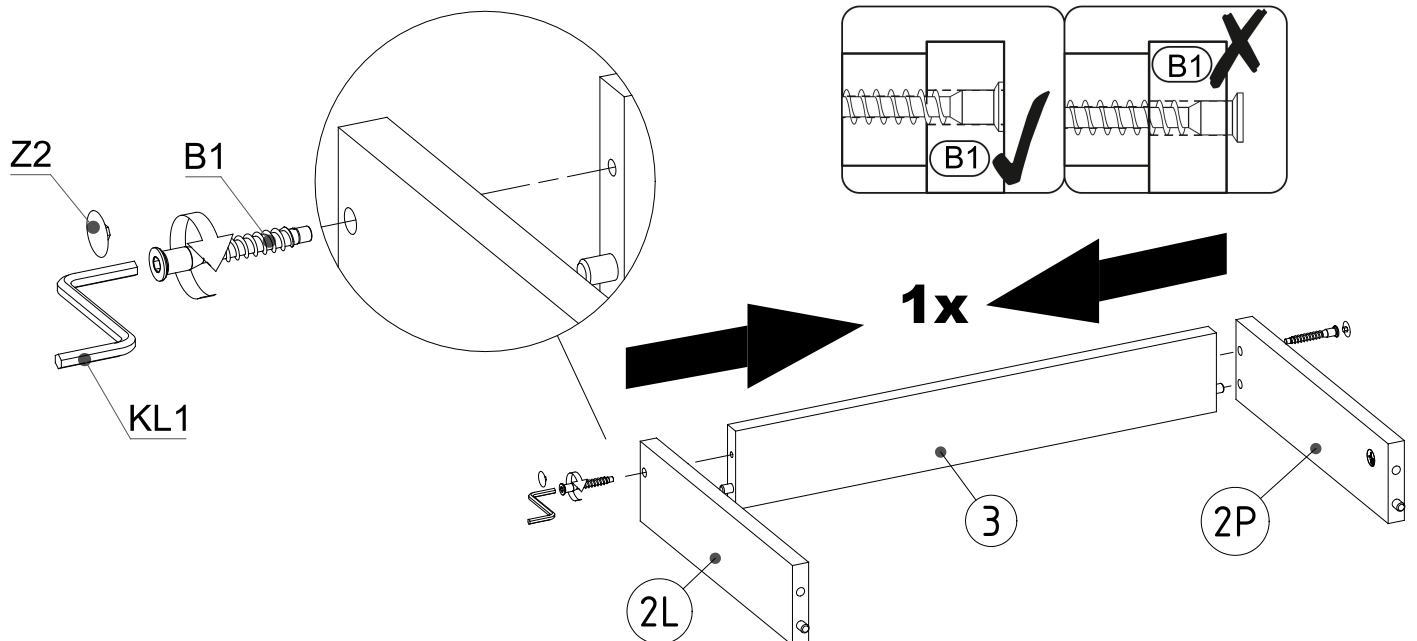
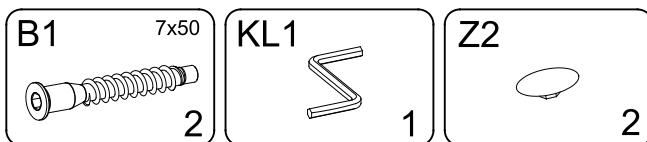

▶ 3

FR Nécessaire au montage:
 DE Sie benötigen für die Montage:
 EN You need for fitting-up:
 PL Niezbędne do montażu:

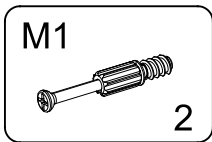
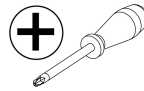

FR: Gauche
 DE: Links
 EN: Left
 PL: Lewa

FR: Droits
 DE: Rechts
 EN: Right
 PL: Prawa

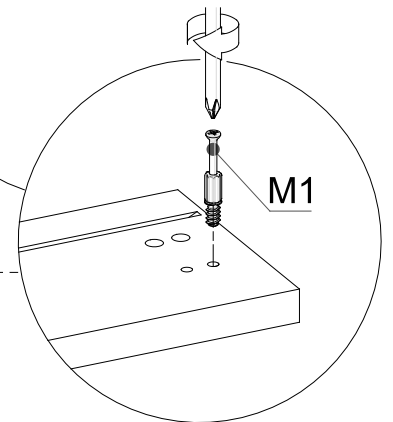
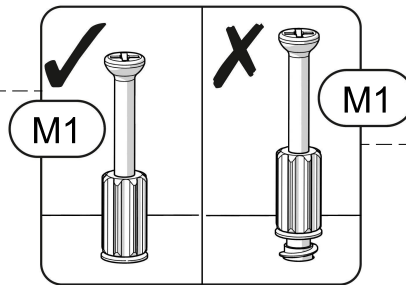
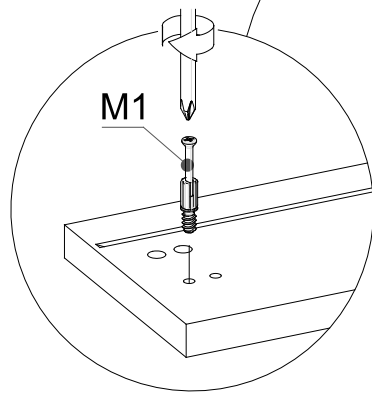
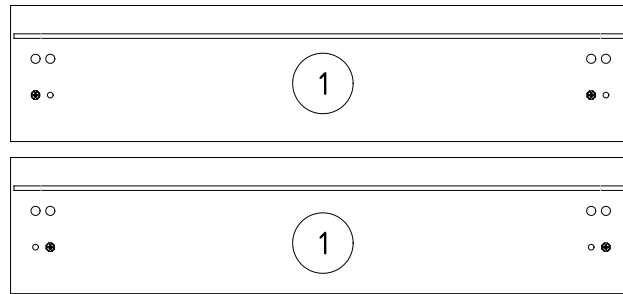
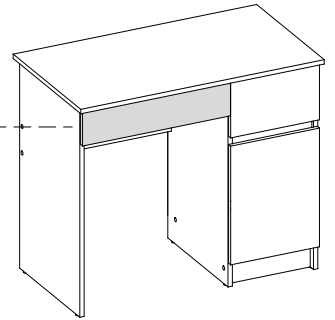
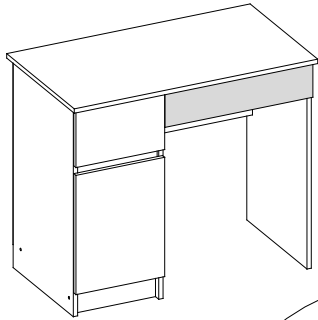

▶ 4

FR Nécessaire au montage:
 DE Sie benötigen für die Montage:
 EN You need for fitting-up:
 PL Niezbędne do montażu:

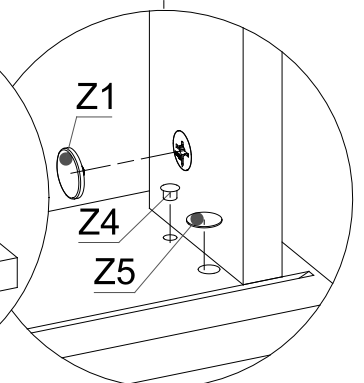
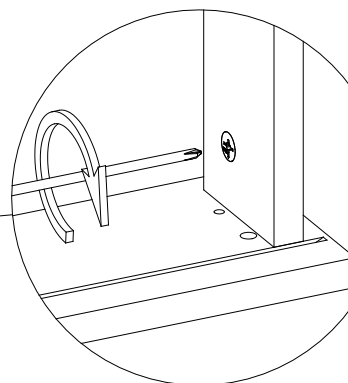
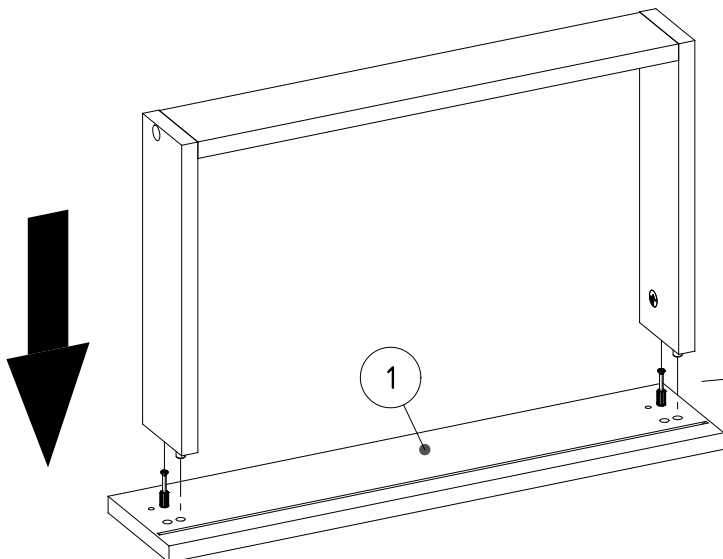
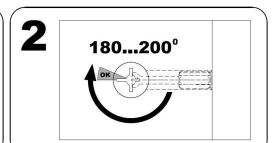
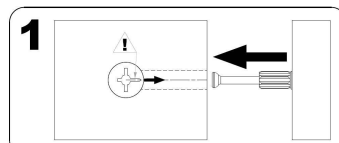
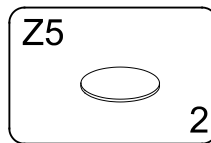
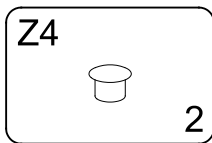
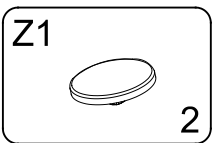

► 5

FR Nécessaire au montage:
DE Sie benötigen für die Montage:
EN You need for fitting-up:
PL Niezbędne do montażu:

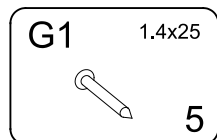

FR: Longueur A = Longueur B
DE: Länge A = Länge B
EN: Length A = Length B
PL: Długość A = Długość B

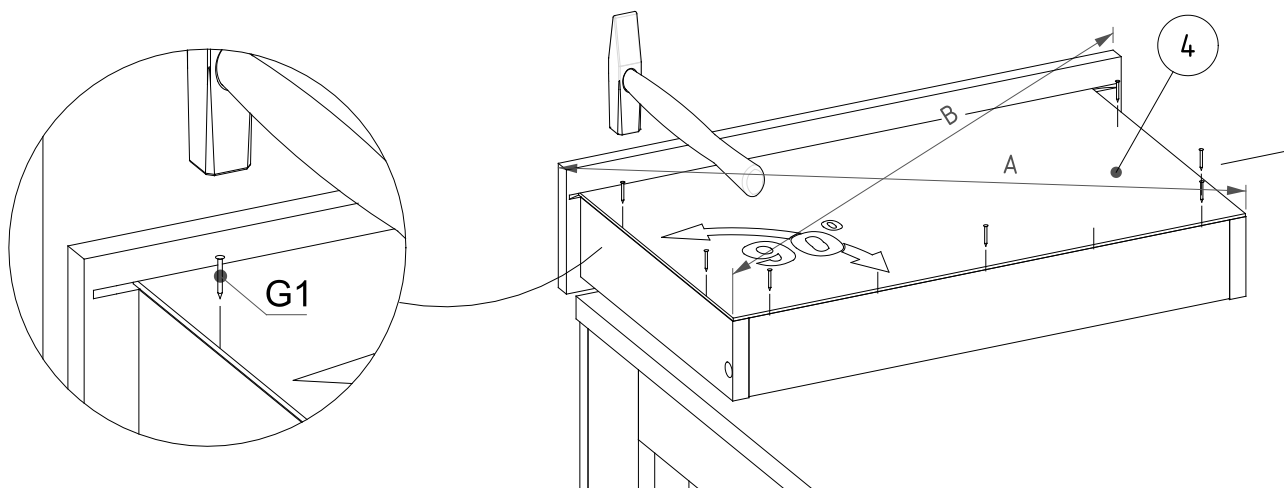

► 6

FR Nécessaire au montage:
DE Sie benötigen für die Montage:
EN You need for fitting-up:
PL Niezbędne do montażu:

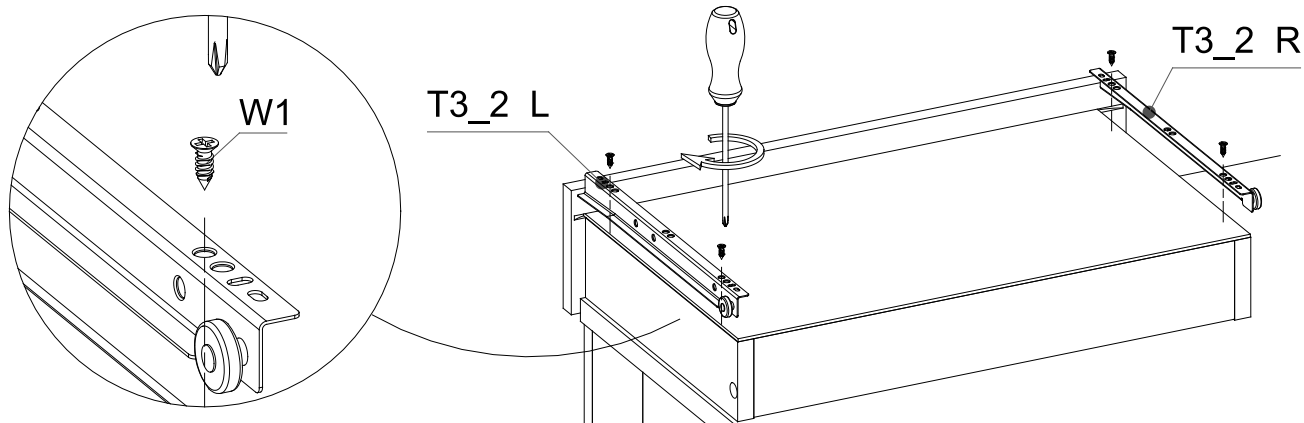
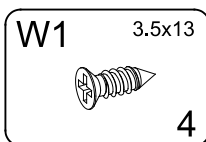
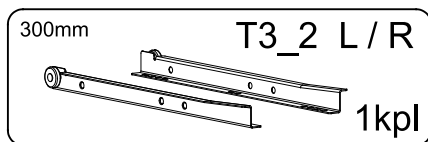
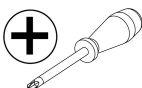

7

FR Nécessaire au montage:
 DE Sie benötigen für die Montage:
 EN You need for fitting-up:
 PL Niezbędne do montażu:

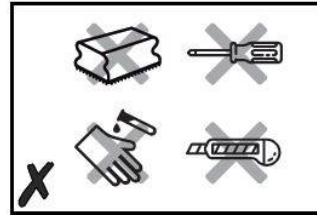
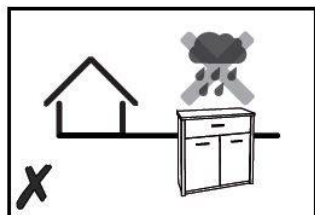
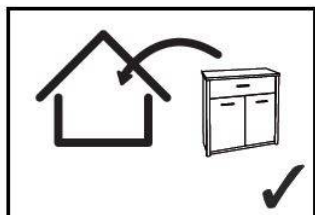
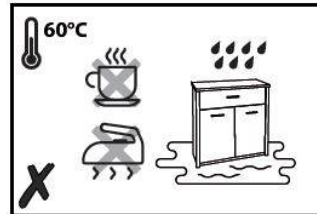
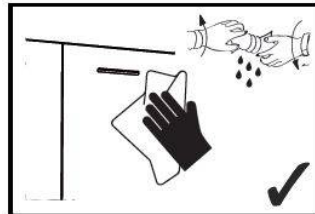
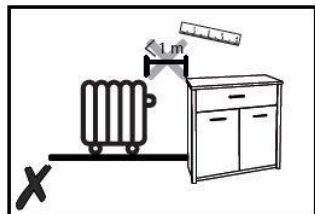
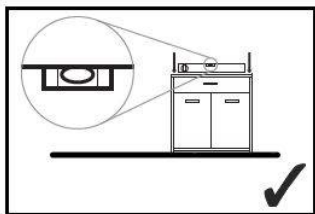
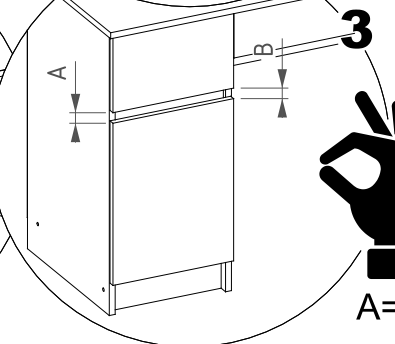
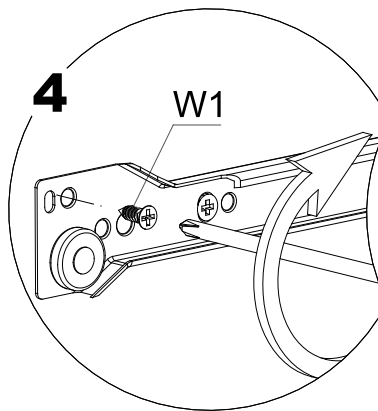
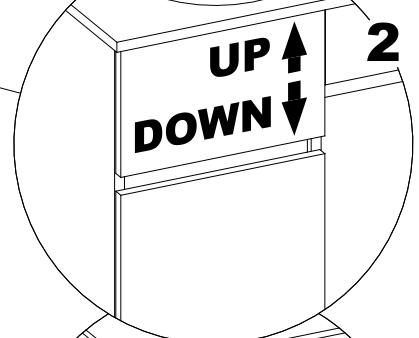
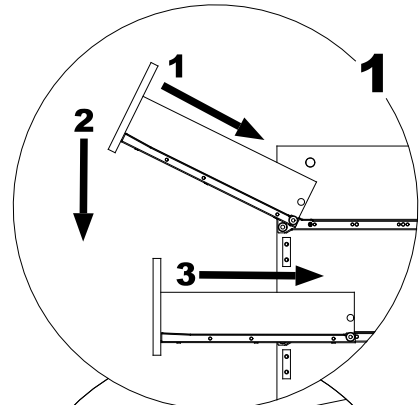
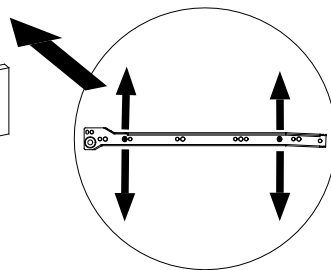
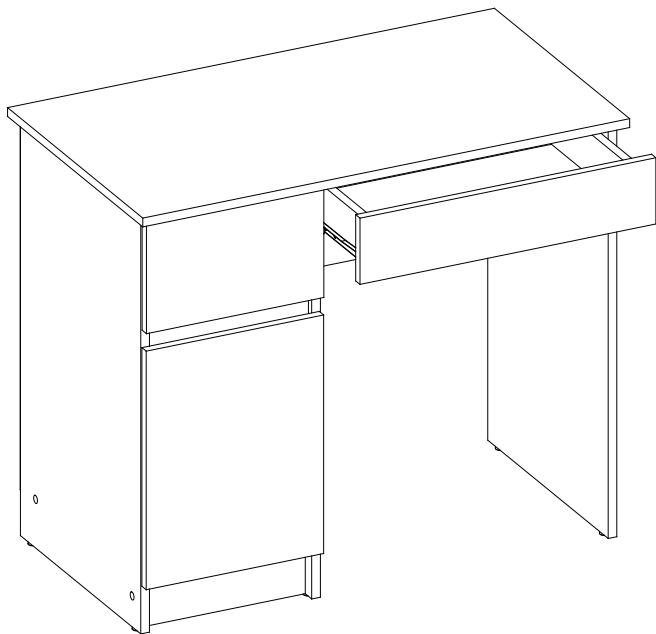
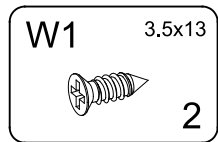

▶ 8

FR Nécessaire au montage:
DE Sie benötigen für die Montage:
EN You need for fitting-up:
PL Niezbędne do montażu:

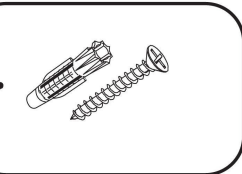
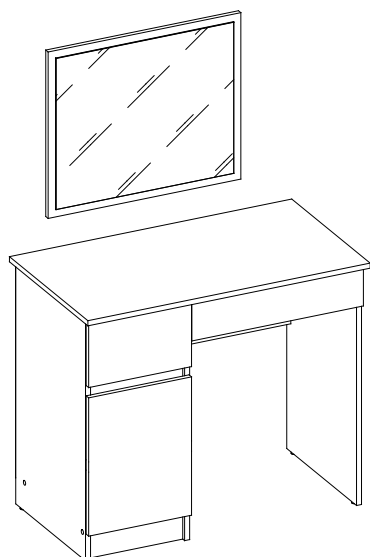
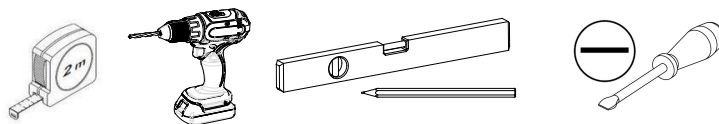

x2



AVERTISSEMENT ANTI-RENVERSEMENT!

Le matériel de montage n'est pas inclus.
Veuillez contacter votre quincaillerie locale pour
obtenir des conseils sur le montage correct
quincaillerie pour votre type de mur.

ANTI-STURZ-WARNUNG!

Montage hardware ist nicht enthalten.
Bitte wenden Sie sich an Ihren örtlichen
Baumarkt, um Ratschläge zur korrekten
Montage für Ihren Wandtyp zu erhalten.

ANTI-TOPPLE WARNING!

Mounting hardware is not included.
Please contact your local hardware store
to get advice on correct mounting hardware
for your type of wall.

OSTRZEŻENIE PRZED WYWRÓCENIEM SIĘ

Produkt musi być na stałe przymocowany
do ściany. Prosimy o skontaktowanie się
ze specjalistycznym sklepem lub fachowcem
w sprawie śrub lub kołków, które należy
zastosować do danego typu ściany.

