

BAR TABLE

ASSEMBLY INSTRUCTION



ASSEMBLY INSTRUCTION

ASSEMBLY TIPS:







- 1.Remove hardware from box and sort by size.
- 2.Please check to see that all hardware and parts are present prior to start of assembly.
- 3.Please follow attached instructions in the same sequence as numbered to assure fast & easy assembly.



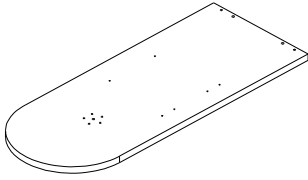

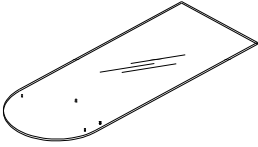
Warning!!

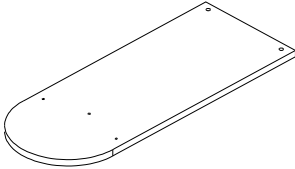
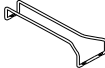
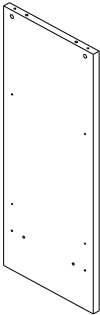
- 1.Don't attempt to repair or modify parts that are broken or defective.Please contact the store immediately.
- 2.This product is for home use only and not intended for commercial establishment.

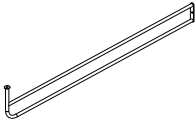
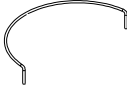
PARTS IDENTIFICATION

(A) TOP SHELF		1PC	(E) TOP BAR		2PCS
(B) GLASS SHELF		1PC	(F) BOTTOM BAR		2PCS
(C) BOTTOM SHELF		1PC	(G) GLASS HOLDER		2PCS
(D) SIDE BOARD		1PC	(H) BOTTOM STEEL GUARD		1PC
			(I) BOTTLE GUARD		2PCS
			(J) GLASS SHELF STEEL GUARD		1PC

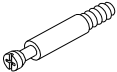
HARDWARE PACKAGE

Z	DESCRIPTION	FIGURE	Q'TY
1	CAM- BOLT		4pcs
2	CAM- LOCK		4pcs

HARDWARE PACKAGE

Z	DESCRIPTION	FIGURE	Q'TY
3	GLUE		1pc
4	GLASS METAL		2pcs
5	GLASS BOLT		2pcs
6	SMALL BOLT		2pcs
7	ROUND IRON		1pc
8	PLASTIC		5pcs
9	WOOD DOWEL		4pcs
10	LABEL		7pcs
11	LARGE ALLEN BOLT		1pc
12	MEDIUM ALLEN BOLT		1pc
13	SMALL ALLEN BOLT		1pc
14	SMALL WASHER		1pc
15	LARGE BOLT		1pc
16	LARGE WASHER		1pc
17	CAP		2pcs
18	SCREW		15pcs
19	SMALL ALLEN KEY		1pc
20	LARGE ALLEN KEY		1pc
21	SPRING WASHER		1pc
22	ALLEN BOLT		2pcs
23	SMALL PLASTIC		2pcs

STEP 1

STEP1:

- 1.Screw Cam-Bolt(1)and Wood Dowel(9) and Round Iron(7)onto Top Shelf(A).

Install Glass Holder(G) using Screw(18)

- 2.Attach Round Iron(7)using Small bolt(6)and attach Top Bar(E)using Small Bolt(6)
- 3.Insert Side Board(D)into Top Shelf(A)then install Cam-Lock(2)and place Label(10) on the screw hole after tightening
- 4.Screw Glass Metal(4)and Screw(18)onto Side Board(D)

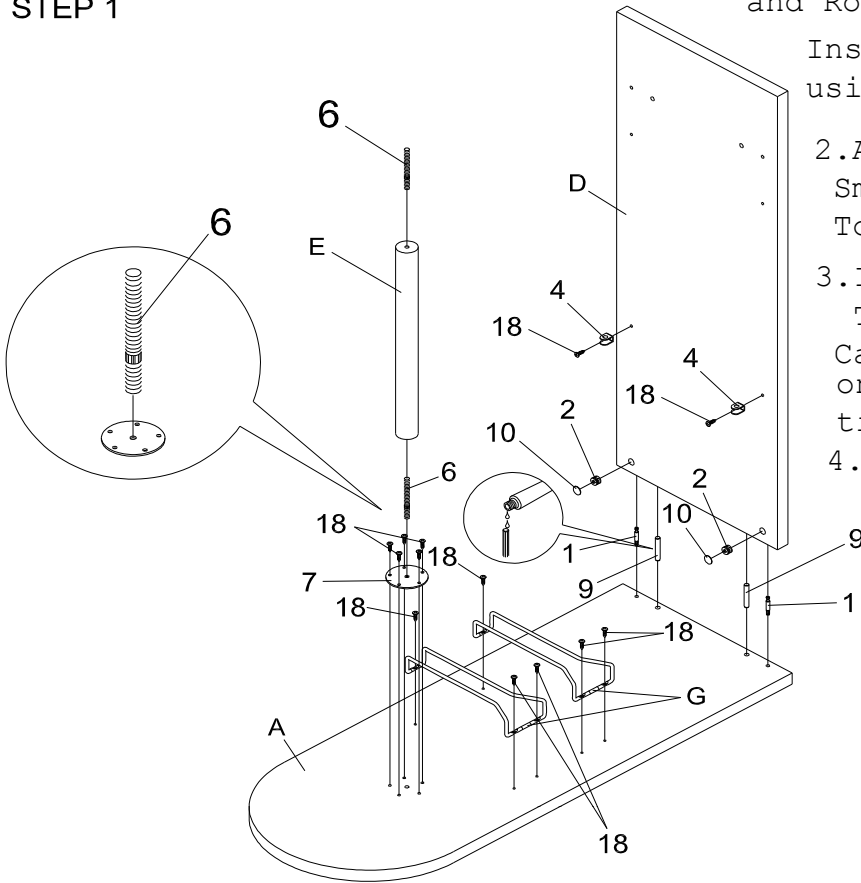

STEP 2

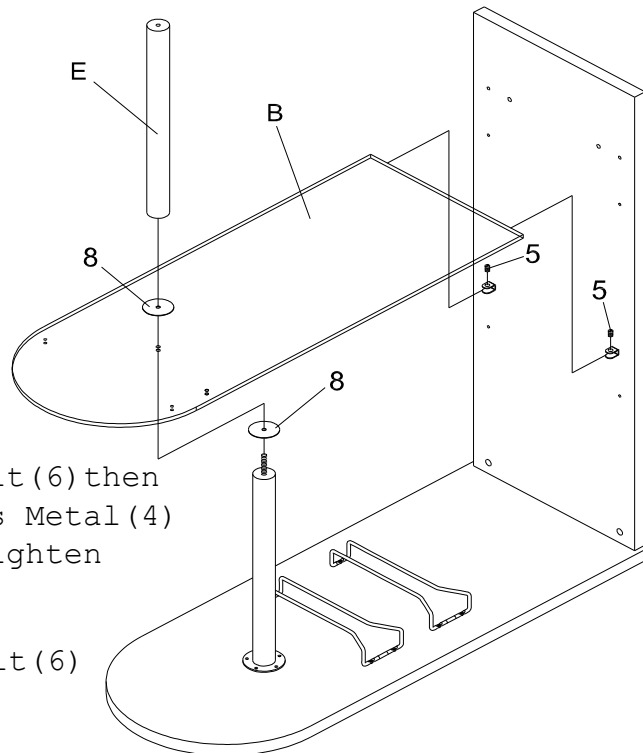

STEP2.

- 1.Place Plastic(8)into Small Bolt(6)then install Small Bolt(6)and Glass Metal(4) onto Glass Shelf(B)and then tighten with Glass Bolt(5)
- 2.Place Plastic(8)into Small Bolt(6) then tighten with Top Bar(E).

STEP 3

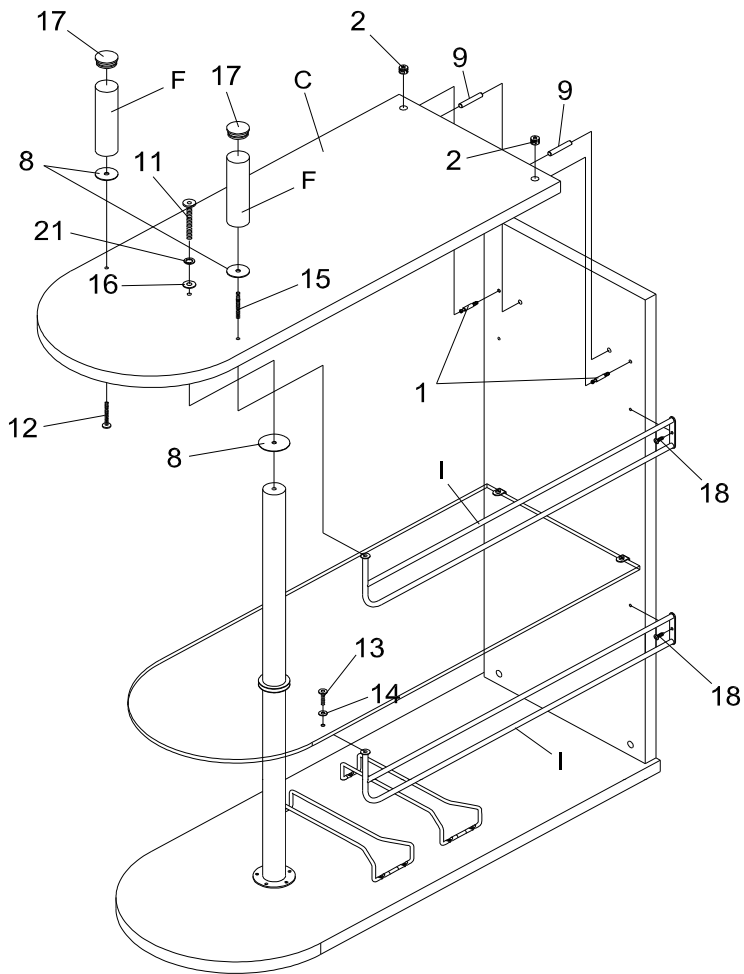

STEP3:

1. Place Plastic (8) into Top Bar (E), screw Cam-BOLT (1) and Wood Dowel (9) onto Side Board (D). Insert Bottom Shelf (C), into Side Board (D) and tighten using Cam-Lock (2)
2. Place Spring Washer (21) and Large Washer (16) onto Large Allen Bolt (11) and then screw it to Bottom Shelf (C) with Top Bar (E) and Plastic (8)
3. Screw Bottle Guard (I) onto Side Board (D) using Screw (18), and screw Bottle Guard (I) to Glass Shelf (B) using Small Allen Bolt (13) and Small Washer (14)
4. Place Plastic (8) and Large Bolt (15) onto Bottom Bar (F), then install Bottom Shelf (C) with Top Bar (E) using Bottom Bar (F). Align Bottom Bar (F) and Bottom Shelf (C) then connect with Bottle Guard (I). Then screw Bottle Guard (I) to the screw with Side Board (D) using Screw (18)
5. Screw Medium Allen Bolt (12) onto Bottom Shelf (C) and assemble Bottom Bar (F) with the Bottom Shelf (C) using the Plastic (8). Add Cap (17) to the Bottom Bar (F) and make sure all screws are tightened.

STEP 4.

1. Insert Bottom Steel Guard(H) onto Bottom Shelf(C)
2. Assemble Glass Shelf Steel Guard(J) with Glass Shelf(B) using Allen Bolt(22) and Small Plastic(23).

FINISH

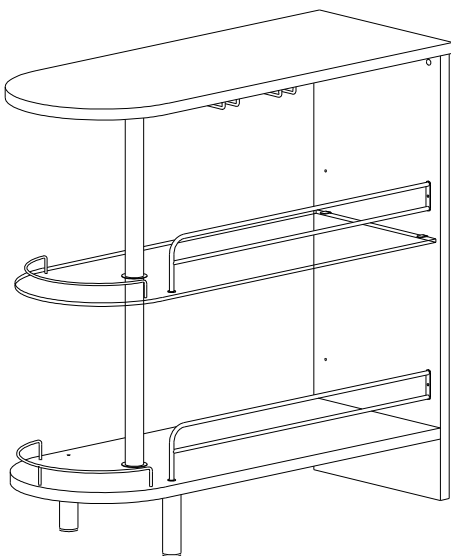

STEP 4

