

# INSTRUCTION MANUAL

## MANUAL DE INSTRUCCIONES

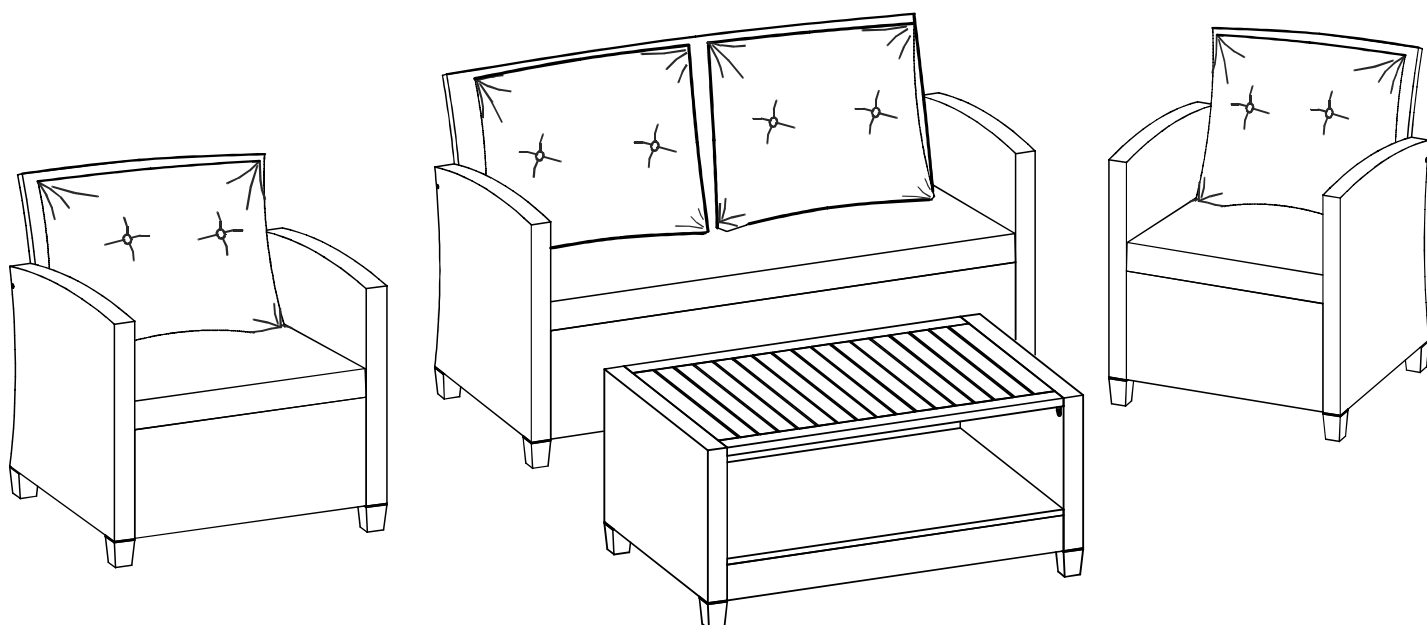

# PACKING DETAILS

## DETALLES DE EMBALAJE

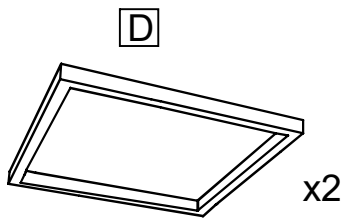

Single Seat  
Asiento Individual

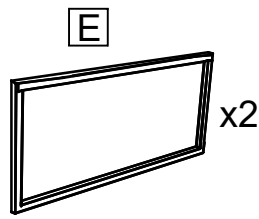

Single Front Seat  
Asiento Delantero Individual

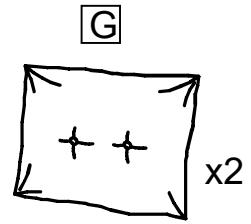

Back Cushion  
Cojín del Respaldo

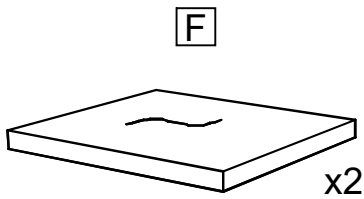

Single Seat Cushion  
Cojín del Asiento Individual

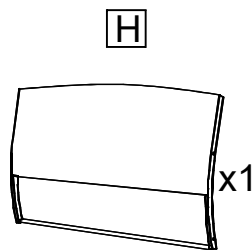

Bench Backrest  
Respaldo del Banco

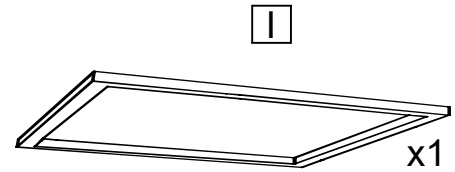

Bench Seat  
Asiento del Banco

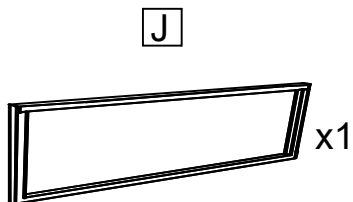

Bench Front Seat  
Asiento Delantero del Banco

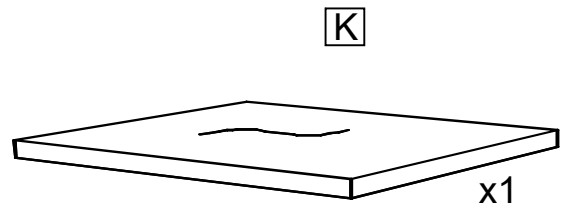

Bench Cushion Seat  
Cojín del Asiento del Banco

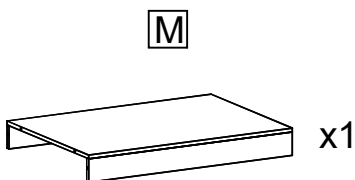

Shelf  
Estante

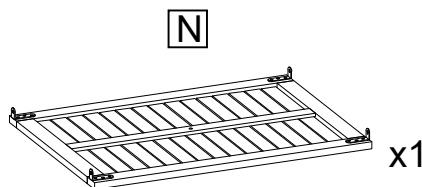
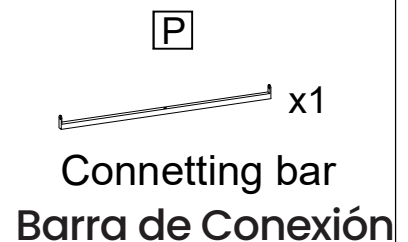

Table Top  
Tablero de Mesa



Connetting bar  
Barra de Conexión

**Hardware**  
**Herrajes**

Carton  
Caja de Cartón  
1/2

# PACKING DETAILS

## DETALLES DE EMBALAJE

A

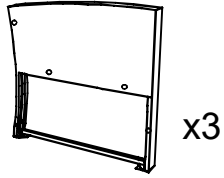

Left Arm  
Brazo Izquierdo

B

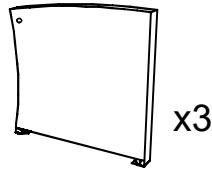

Right Arm  
Brazo Derecho

C

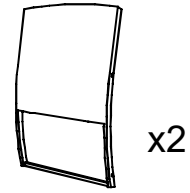

Single Backrest  
Respaldo Individual

L

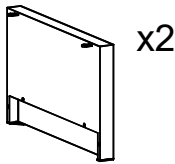
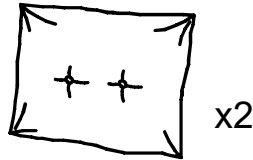

Table Leg  
Pata de Mesa

G



Back Cushion  
Cojín del Respaldo

Carton  
Caja de Cartón  
2/2

# PART LIST

## LISTA DE PARTES

**A** Left Arm  
Brazo Izquierdo

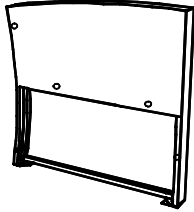

(3 pcs)

**B** Right Arm  
Brazo Derecho

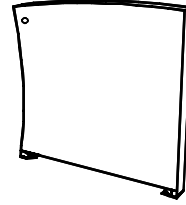

(3 pcs)

**C** Single Backrest  
Respaldo Individual

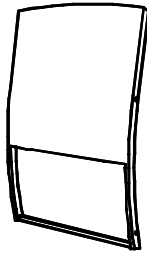

(2 pcs)

**D** Single Seat  
Asiento Individual

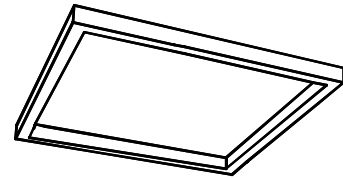

(2 pcs)

**E** Single Front Seat  
Asiento Delantero Individual

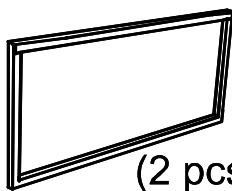

(2 pcs)

**F** Single Seat Cushion  
Cojín del Asiento Individual



(2 pcs)

**G** Back Cushion  
Cojín del Respaldo

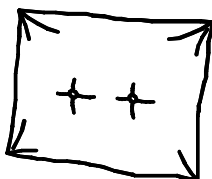

(4pcs)

**H** Bench Backrest  
Respaldo del Banco

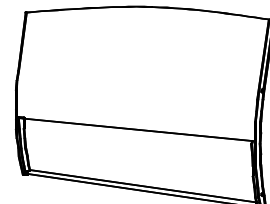

(1 pc)

**I** Bench Seat  
Asiento del Banco

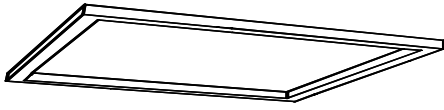

(1 pc)

**J** Bench Front Seat  
Asiento Delantero del Banco

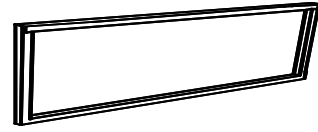

(1 pc)

**K** Bench Cushion Seat  
Cojín del Asiento del Banco



(1 pc)

**L** Table Leg  
Pata de Mesa

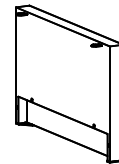

(2 pcs)

**M** Shelf  
Estante

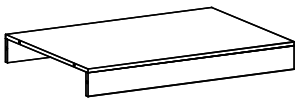

(1 pc)

**N** Table Top  
Tablero de Mesa

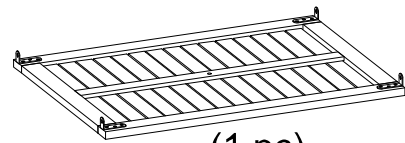

(1 pc)





**P** Connetting bar  
Barra de Conexión

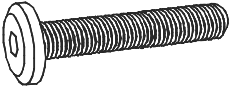
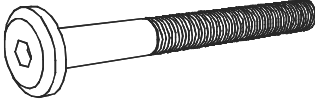
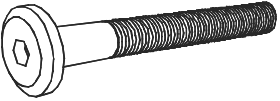

(1 pc)

# HARDWARE LIST

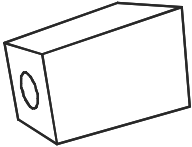
## LISTA DE HERRAJES

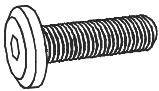
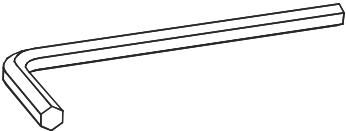
<p>01 Bolt Perno</p>  <p>M6 x 40 mm (26 pcs)</p>	<p>02 Bolt Perno</p>  <p>M6 x 65 mm (6 pcs)</p>
<p>03 Bolt Perno</p>  <p>M6 x 55 mm (16 pcs)</p>	<p>04 Washer Arandela</p>  <p>Ø6 x 14 mm (60 pcs)</p>
<p>05 Feet Plastic Patatas de Plástico</p>  <p>(16 pcs)</p>	<p>06 Bolt Perno</p>  <p>M6 x 30 mm (22 pcs)</p>
<p>07 Cap Tapa</p>  <p>M4 (6 pcs)</p>	<p>08 Bolt Perno</p>  <p>M6x15 mm (6 pcs)</p>
<p>09 Allen key 4 x 98 Llave Allen x 98</p>  <p>(2 pcs)</p>	

**STEP 1**  
**PASO 1**

**x2**

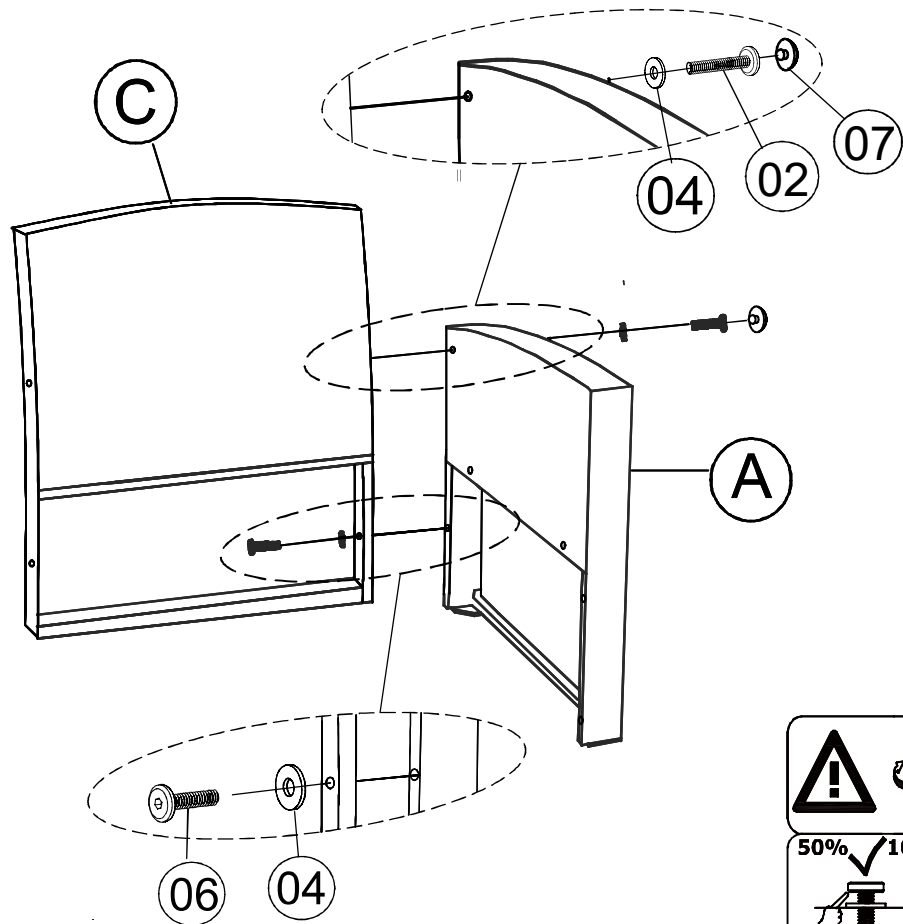

02		1
06		1
04		2
07		1

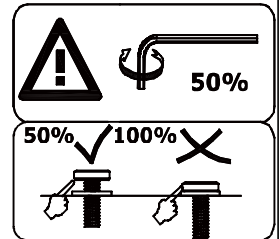

**STEP 2**  
**PASO 2**

**x2**

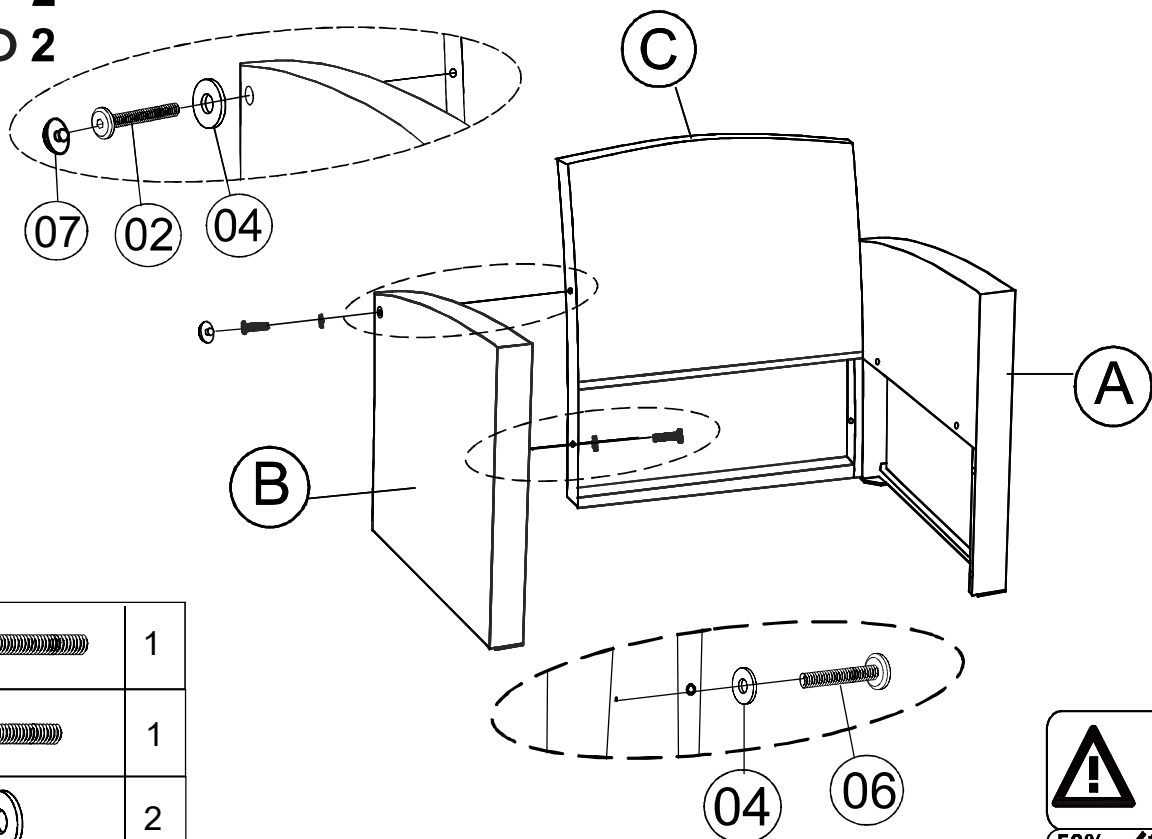

02		1
06		1
04		2
07		1

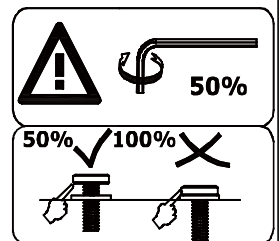

**STEP 3**  
**PASO 3**

**x2**

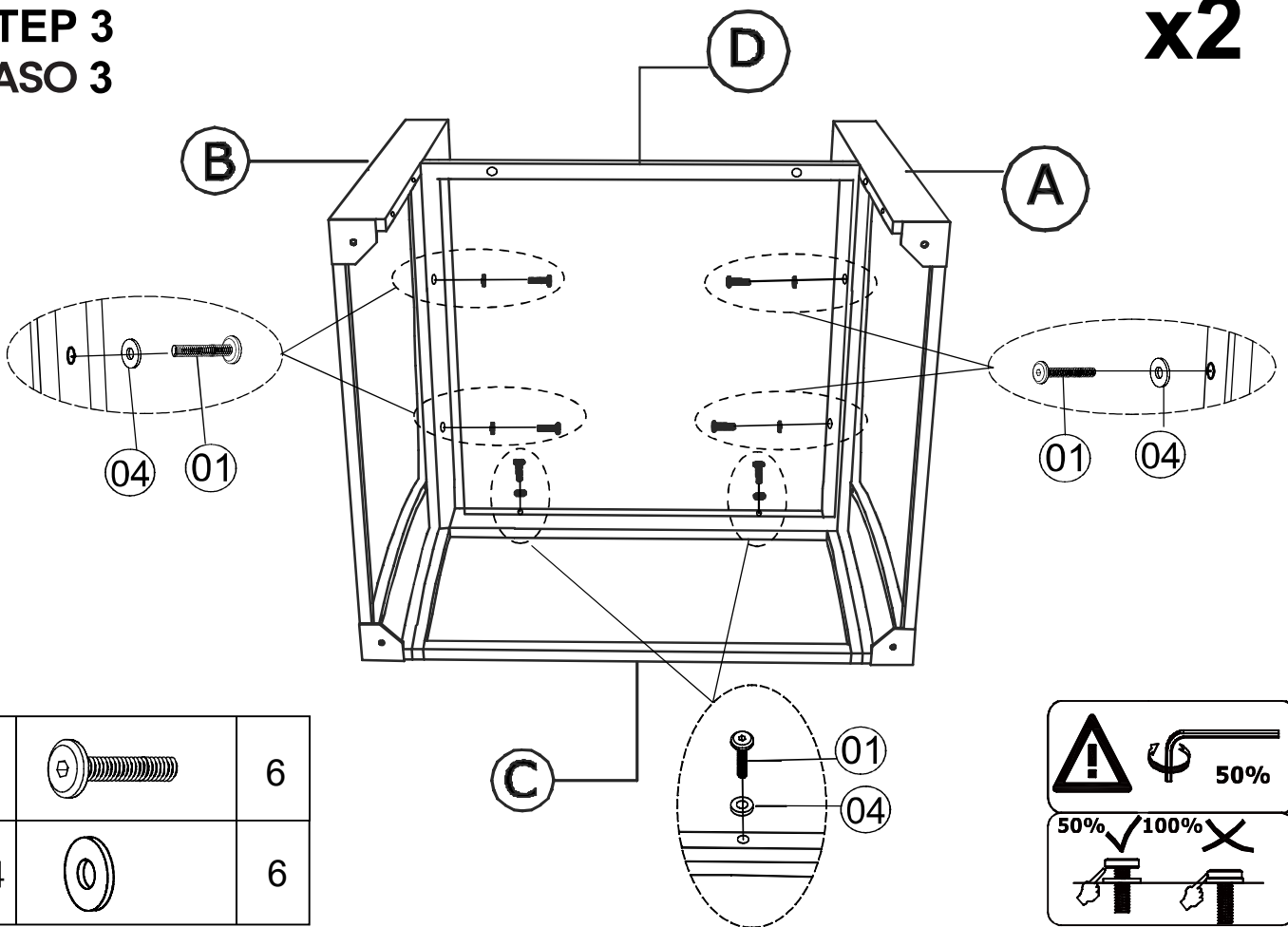

01		6
04		6

**STEP 4**  
**PASO 4**

**x2**

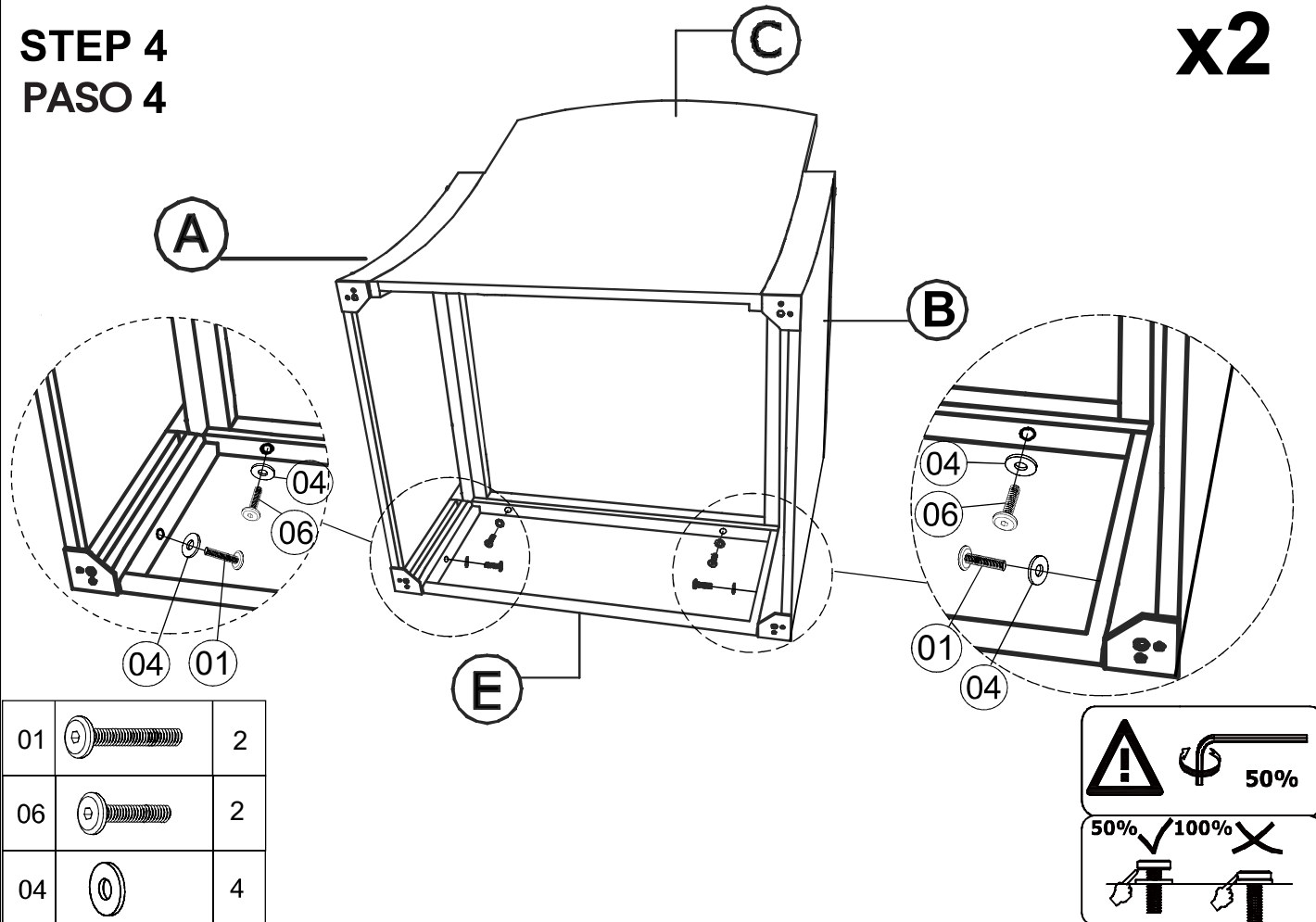



01		2
06		2
04		4

**STEP 5**  
**PASO 5**

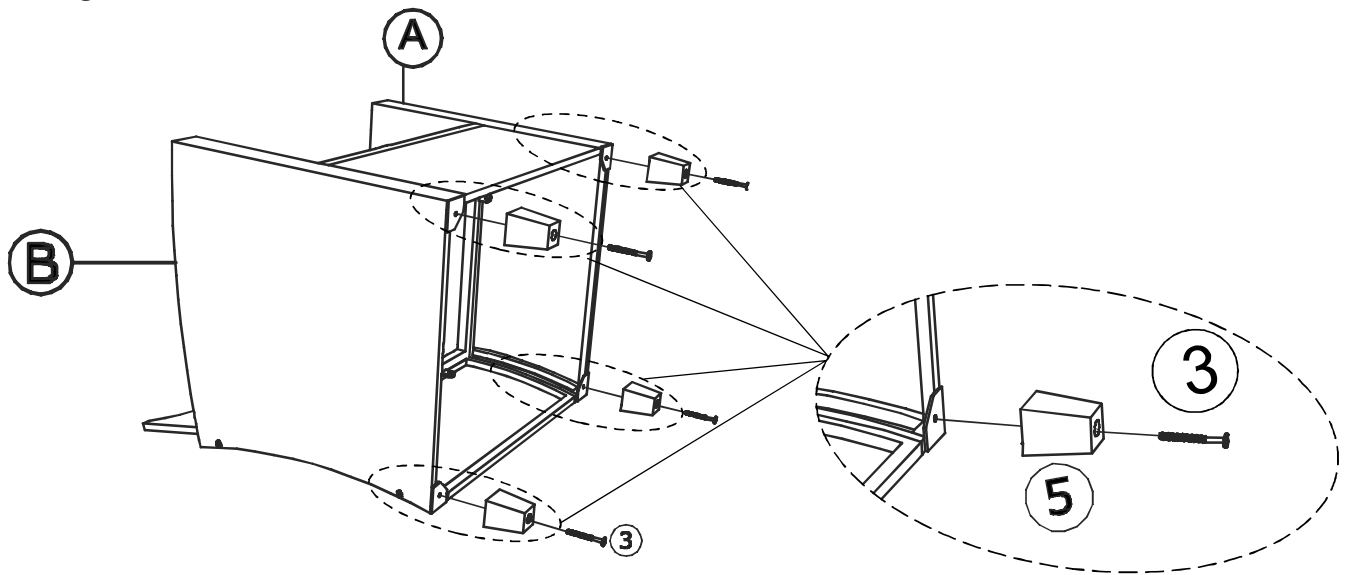
**x2**



03		4
05		4

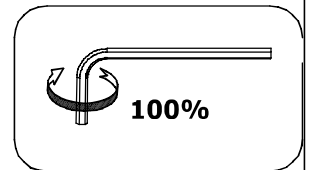

**STEP 6**  
**PASO 6**

**x2**

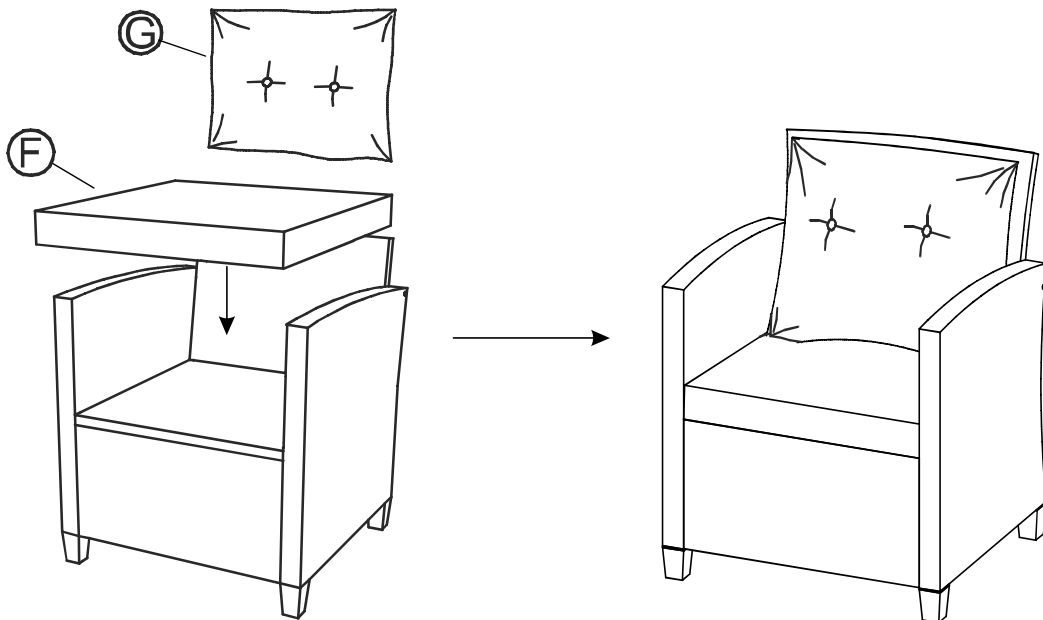

**FINISH**

# STEP 7 PASO 7

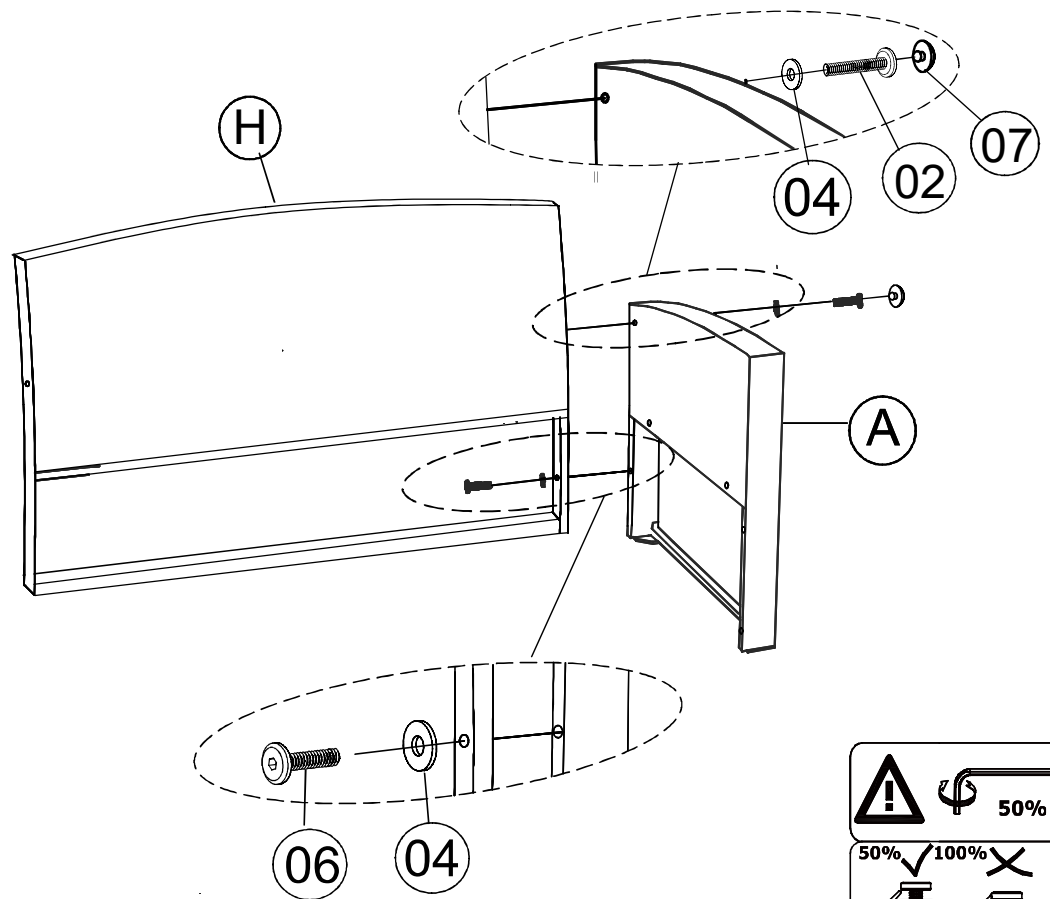

02		1
06		1
04		2
07		1

50%

50% ✓ 100% ✗

# STEP 8 PASO 8

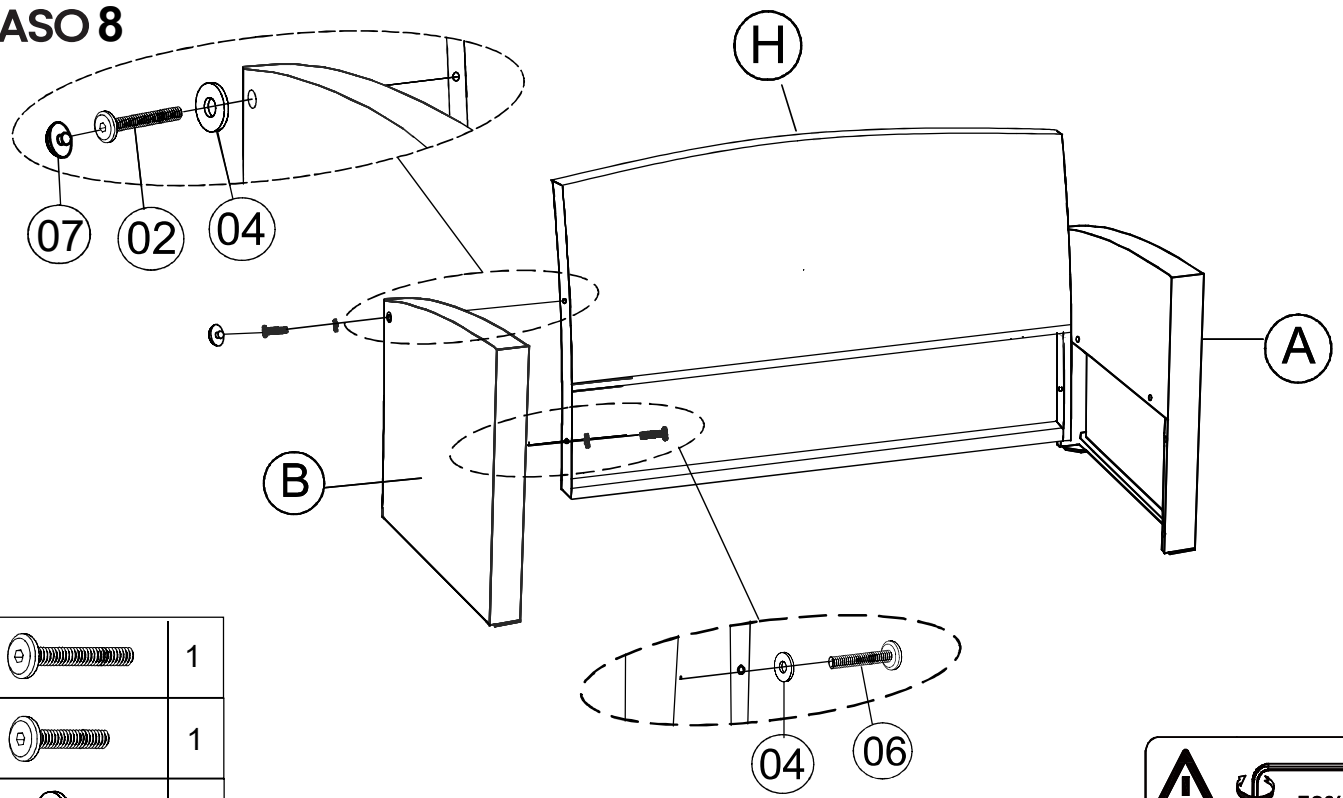

02		1
06		1
04		2
07		1

50%

50% ✓ 100% ✗

# STEP 9 PASO 9

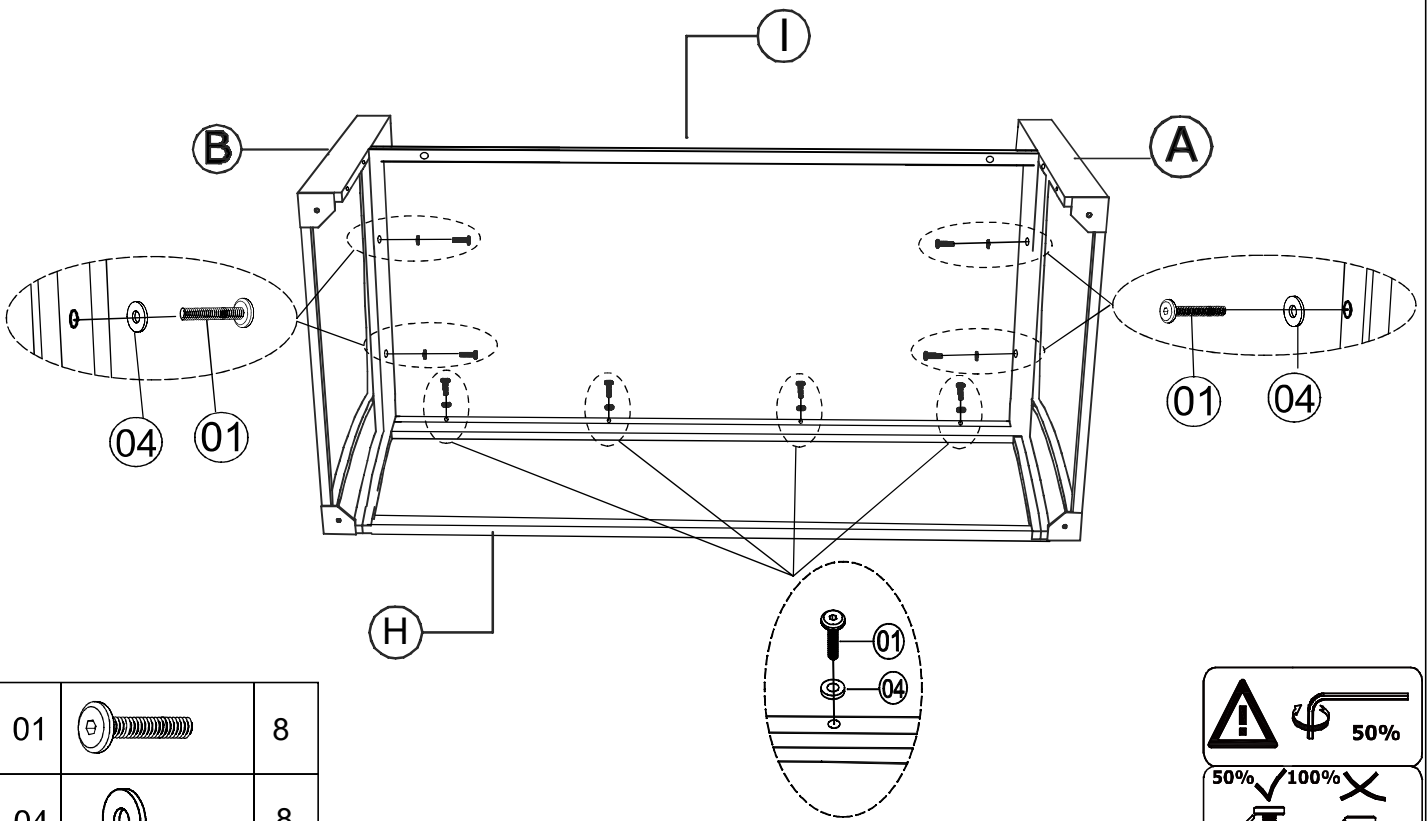

01		8
04		8

50%

50% 100%

# STEP 10 PASO 10

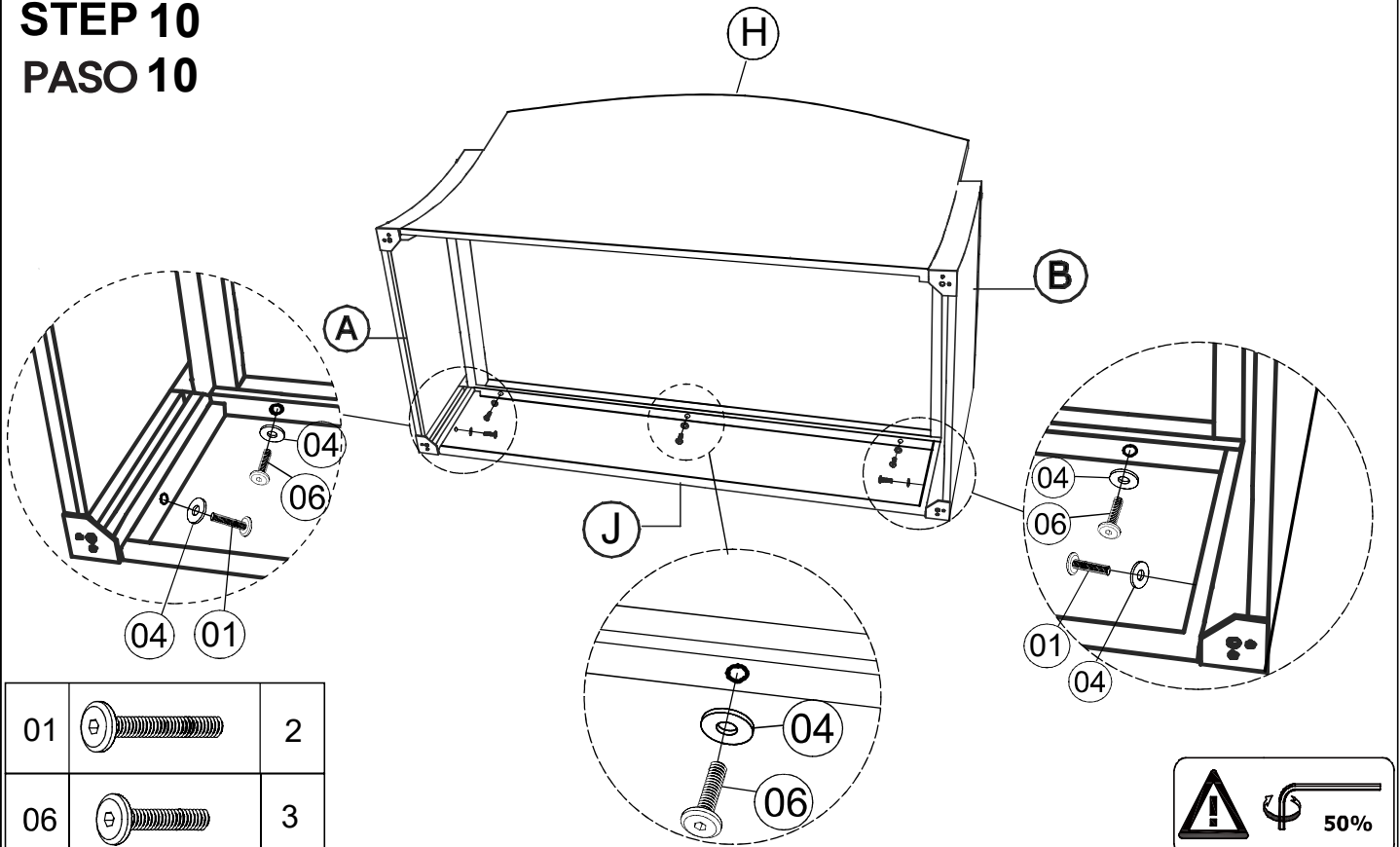



01		2
06		3
04		5

50%

50% 100%

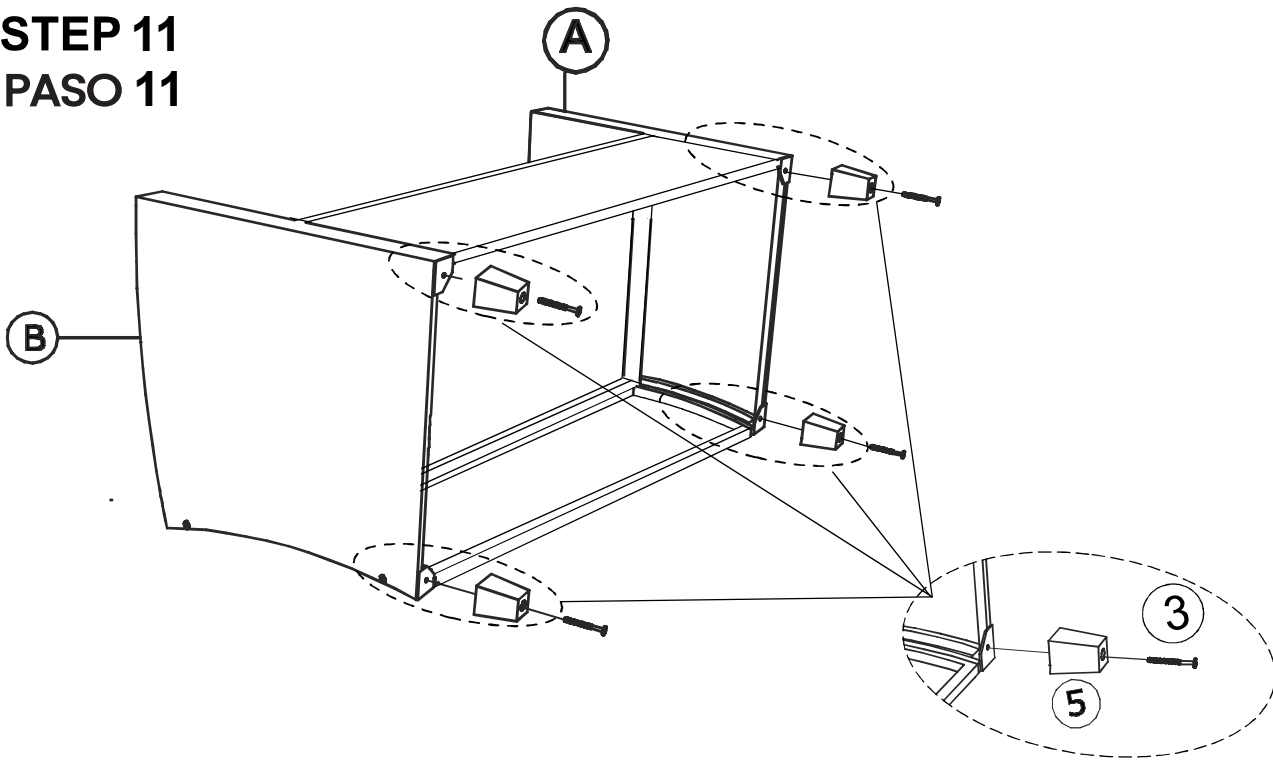
**STEP 11**  
**PASO 11**



03		4
05		4

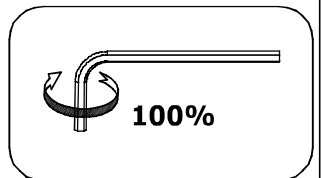

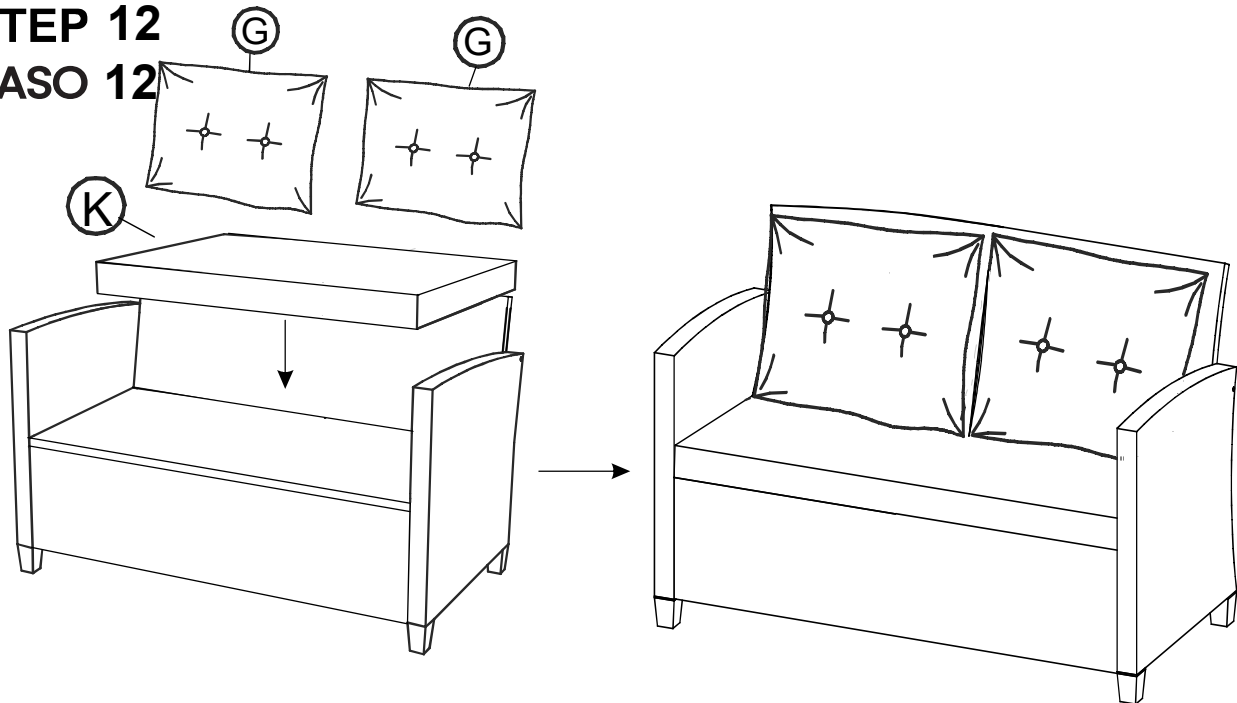

**STEP 12**  
**PASO 12**

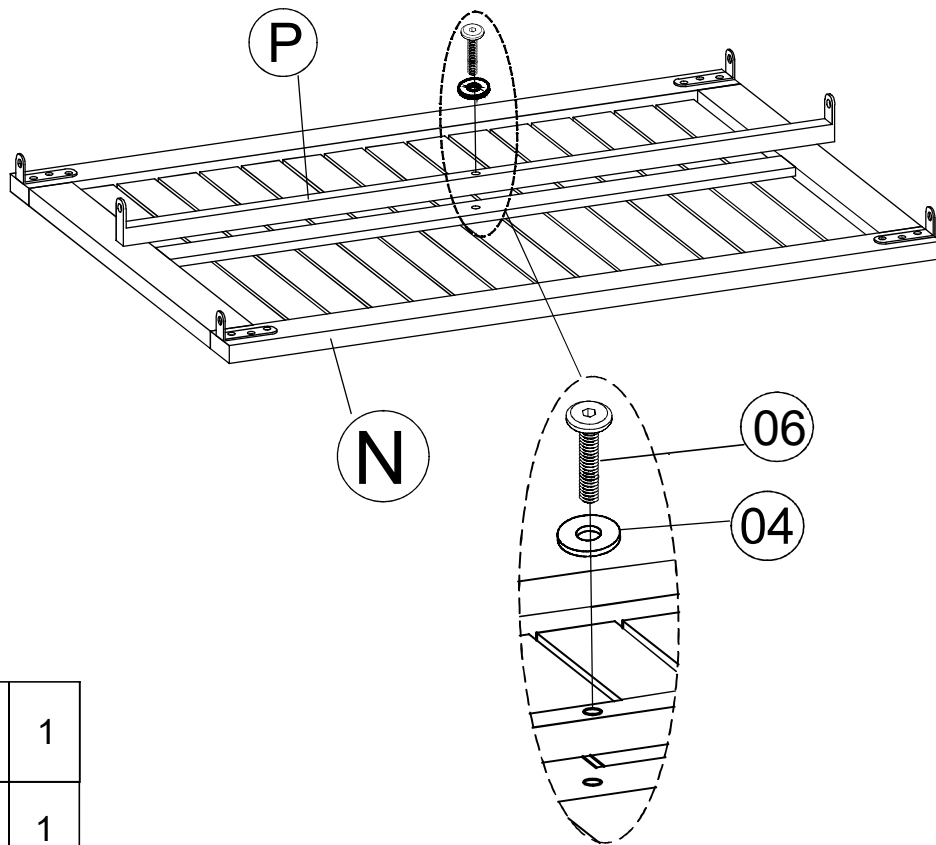

**FINISH**

**STEP 13**  
**PASO 13**



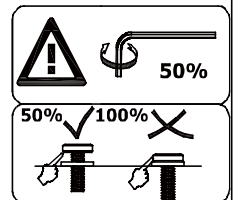

06		1
04		1

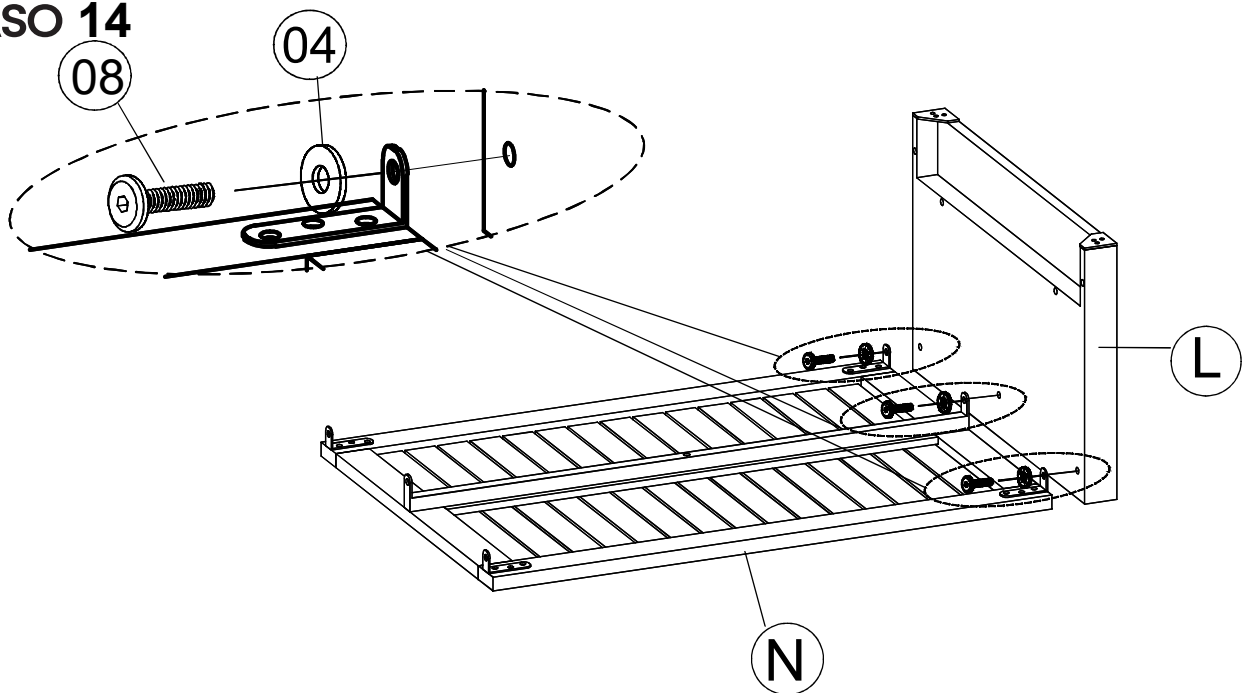

**STEP 14**  
**PASO 14**

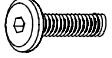

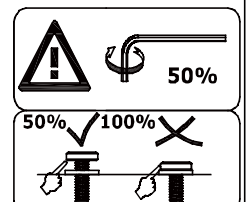

08		3
04		3

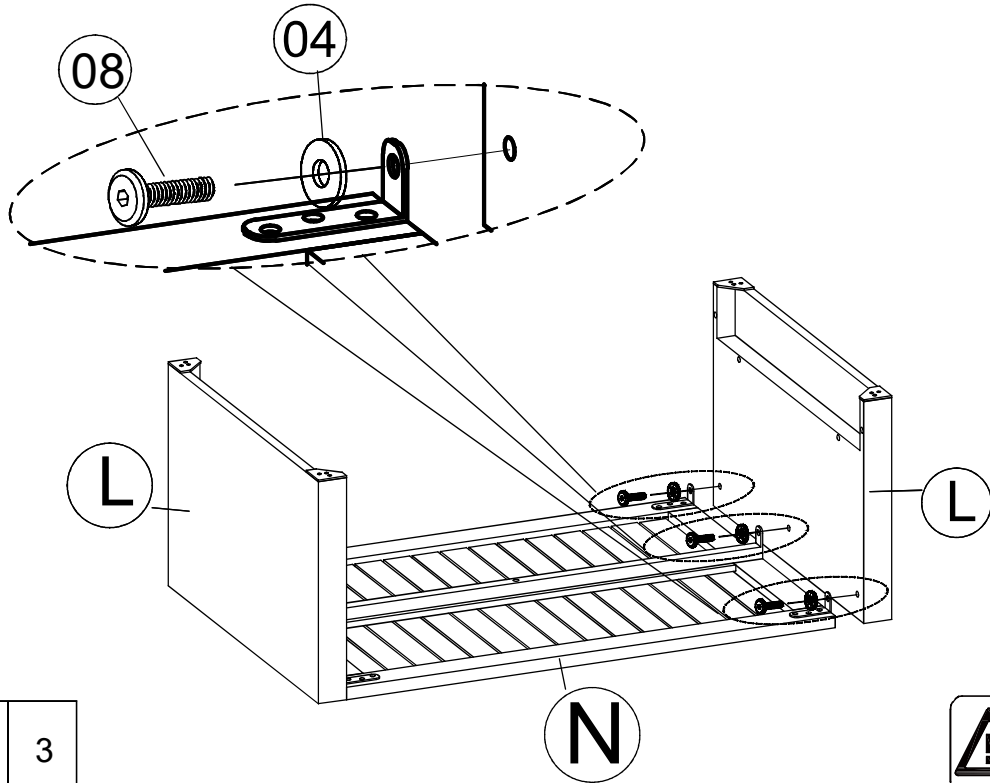

**STEP 15**  
**PASO 15**



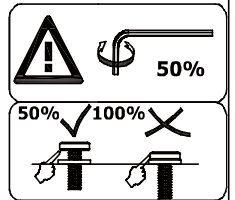

08		3
04		3

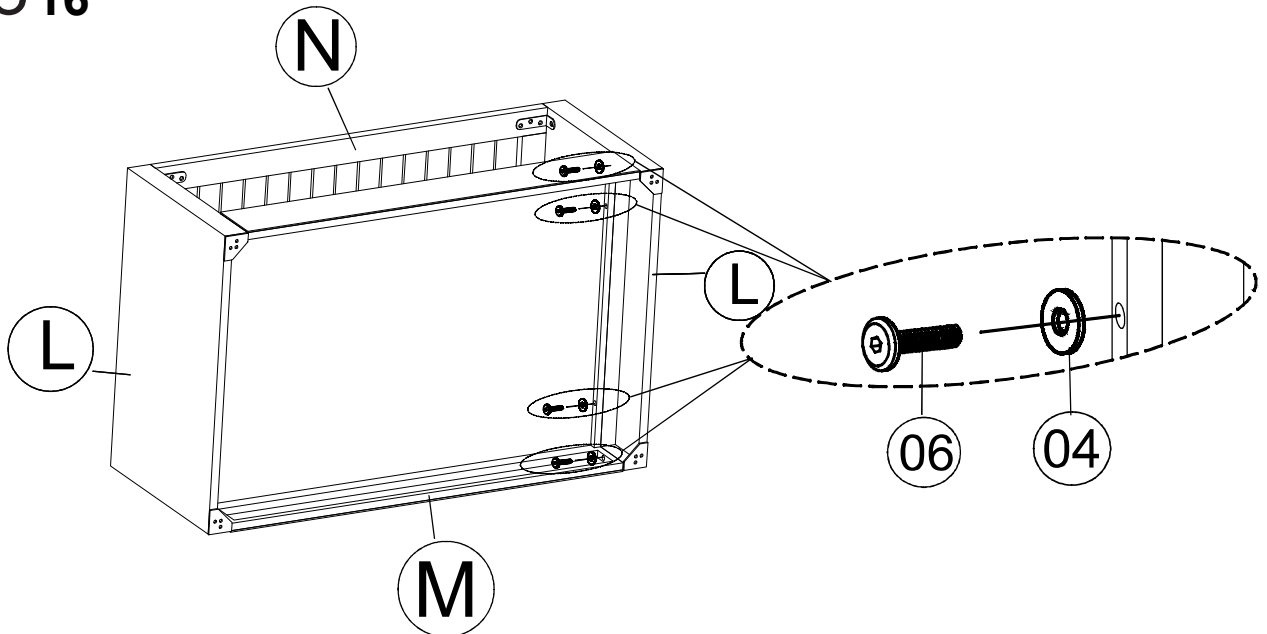

**STEP 16**  
**PASO 16**

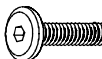

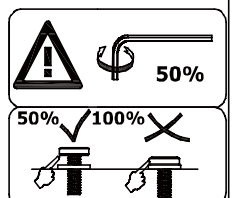

06		4
04		4

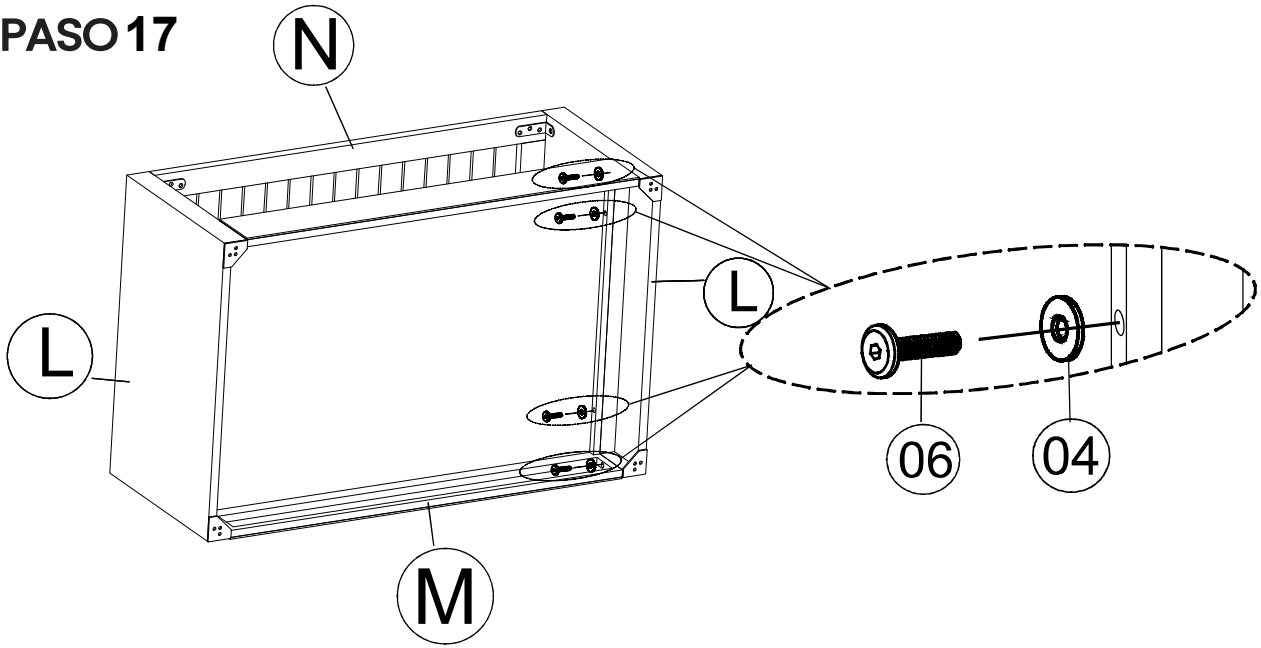

**STEP 17**  
**PASO 17**



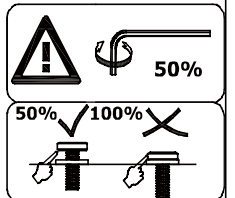

06		4
04		4

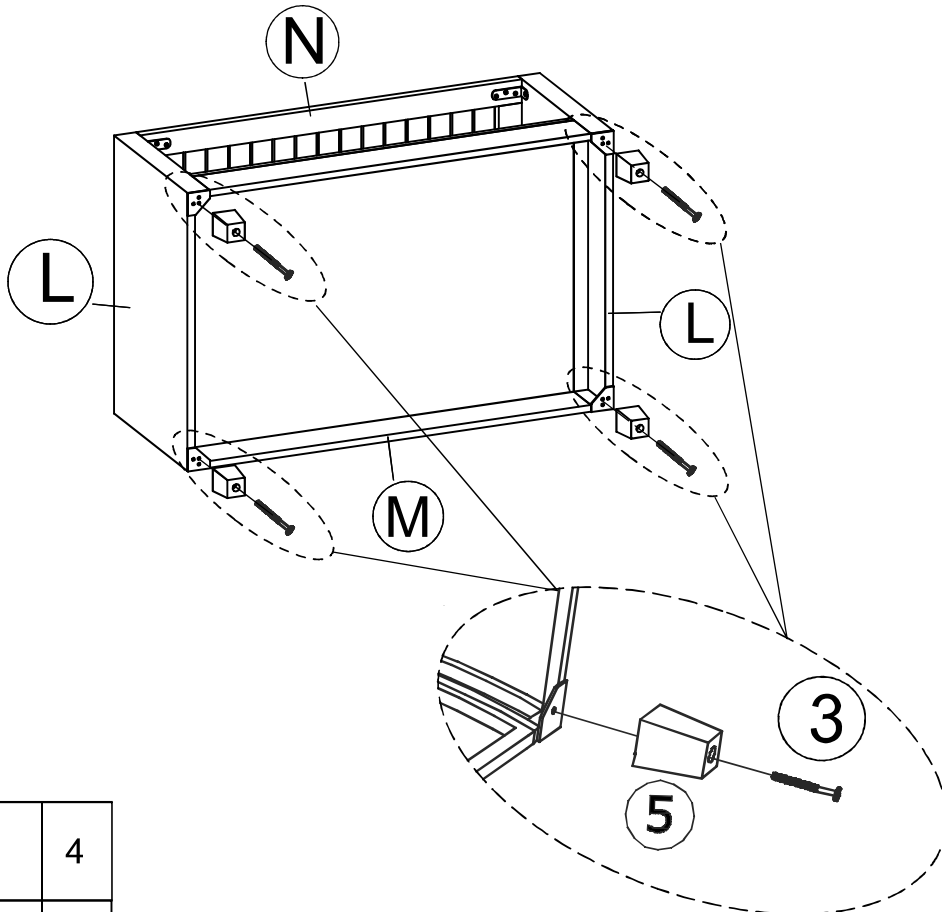

**STEP 18**  
**PASO 18**



03		4
05		4

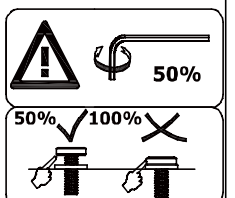

**STEP 19**  
**PASO 19**

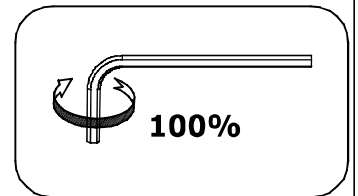
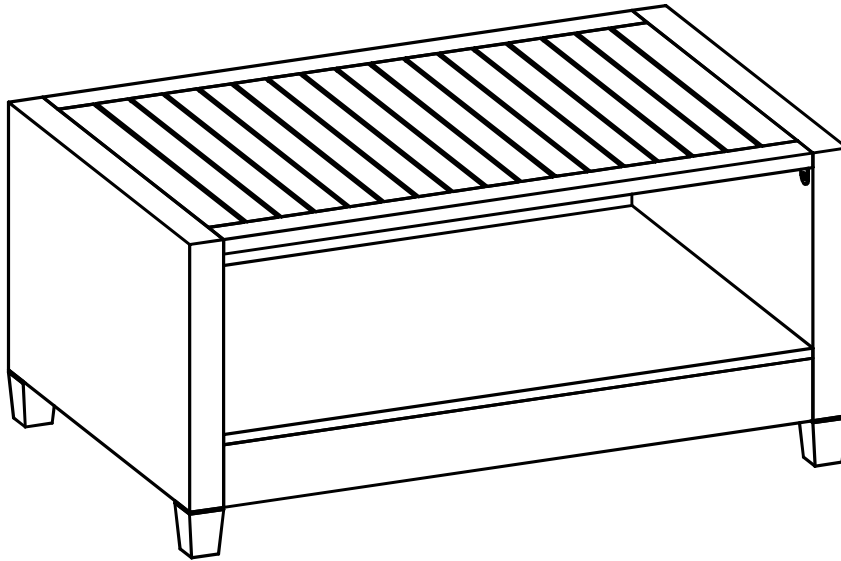

**STEP 20**  
**PASO 20**

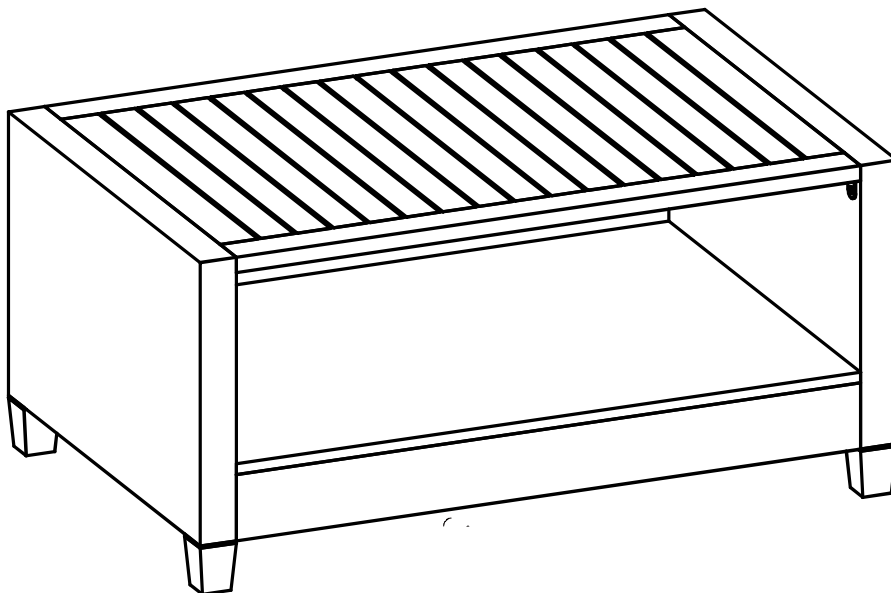

**FINISH**



## MAINTENANCE AND CARE

Protect your furniture from extreme weather conditions by moving it to a covered area. Alternatively, use furniture covers or traps for added protection.

Avoid dragging or placing heavy objects on the furniture to prevent potential damage.

Regularly inspect your furniture for signs of wear, loose strands, or damage. Address any issues promptly.

Hardware may loosen over time. Periodically check to make sure all connections are tight. Re-tighten if necessary.

Do not dispose of any packaging or contents of the shipping carton until assembly is completed to avoid accidentally discarding small parts or hardware.

Do not use sharp objects that may scratch the painted surface.

Clean with a damp cloth soaked in warm soapy water or a specialized, suitable cleaning product.

Conclude the cleaning process by wiping with a clean, dry cloth.

Ensure proper drying after cleaning or exposure to rain to prevent mold or mildew growth.



## WARRANTY INFORMATION

**Warranty Coverage:** Our warranty provides protection against manufacturing defects in materials and workmanship for a specified period from the date of purchase, as outlined in the accompanying warranty documentation.

**Exclusions:** The warranty does not cover damages resulting from misuse, negligence, accidents, normal wear and tear, unauthorized repairs or modifications, improper assembly, or failure to adhere to the care and maintenance guidelines provided.

## WARRANTY CLAIM PROCESS

**To initiate a return, please follow these steps:**

- 1 Log into your account and go to the "Your Orders" section.
- 2 Locate the order containing the item you wish to return.
- 3 Contact our customer service for assistance in obtaining a prepaid return label.
- 4 Once you receive the return label, securely affix it to the package.
- 5 You can then choose to drop off the package at a designated carrier location or arrange for a pickup.
- 6 After we receive and inspect the returned product, we will initiate the refund process.
- 7 The refund will be credited back to the original payment method used during the purchase.
- 8 Typically, refunds are processed within 3-5 business days.



## MANTENIMIENTO Y CUIDADO

Proteja sus muebles de condiciones climáticas extremas moviéndolos a un área cubierta. Alternativamente, use fundas o protectores para muebles para una protección adicional. Evite arrastrar o colocar objetos pesados sobre los muebles para prevenir posibles daños. Inspeccione regularmente sus muebles en busca de signos de desgaste, hilos sueltos o daños. Trate cualquier problema de inmediato.

Los herrajes pueden aflojarse con el tiempo. Revise periódicamente para asegurarse de que todas las conexiones estén ajustadas. Vuelva a apretar si es necesario.

No deseche ningún embalaje o contenido de la caja de envío hasta que se complete el ensamblaje para evitar descartar accidentalmente partes pequeñas o herrajes.

No use objetos afilados para rasgar la superficie pintada. No recomendamos el uso de limpiadores químicos, abrasivos o pulidores de muebles en nuestro acabado lacado.

Limpie con un paño húmedo empapado en agua jabonosa tibia o un producto de limpieza especializado y adecuado.

Concluya el proceso de limpieza secando con un paño limpio y seco.

Asegúrese de que los muebles se sequen adecuadamente después de la limpieza o la exposición a la lluvia para evitar el crecimiento de moho o hongos.

Evite colocar vasos transparentes sobre la superficie del panel de madera-plástico durante mucho tiempo para evitar que la luz solar concentrada derrita la superficie.



## INFORMACIÓN DE GARANTÍA

**Cobertura de la garantía:** Nuestra garantía proporciona protección contra defectos de fabricación en materiales y mano de obra durante un período especificado desde la fecha de compra, como se detalla en la documentación de garantía adjunta.

**Exclusiones:** La garantía no cubre daños resultantes de mal uso, negligencia, accidentes, desgaste normal, reparaciones o modificaciones no autorizadas, ensamblaje incorrecto o el incumplimiento de las pautas de cuidado y mantenimiento proporcionadas.

## PROCESO DE RECLAMO DE GARANTÍA

**Para iniciar una devolución, siga estos pasos:**

- 1 Inicie sesión en su cuenta y vaya a la sección "Tus pedidos".
- 2 Ubique el pedido que contiene el artículo que desea devolver.
- 3 Póngase en contacto con nuestro servicio al cliente para recibir asistencia y obtener una etiqueta de devolución prepaga.
- 4 Una vez reciba la etiqueta de devolución, colóquela de manera segura en el paquete.
- 5 Luego, puede optar por dejar el paquete en un punto de entrega designado o coordinar una recogida.
- 6 Después de recibir e inspeccionar el producto devuelto, iniciaremos el proceso de reembolso.
- 7 El reembolso será acreditado de vuelta al método de pago original utilizado durante la compra.
- 8 Por lo general, los reembolsos se procesan en un plazo de 3 a 5 días hábiles.