

# Invisia™ Shampoo Shelf

with Support Rail

INVISIA  
LIVE BEAUTIFULLY

## Technical Data Sheet

### Product Specification

The product shall be a combination shampoo shelf and grab rail. The product shall have a removable solid surface shelf. The product shall have patented discreet wall mounts that conceal the mounting hardware. There shall be four points of contact between the product and the wall. The grab rail portion of the product shall be 1.25"/3.2cm in diameter. The product shall be suitable for use in a wet environment. The product shall have a weight capacity in excess of 500lbs / 227kg. Product shall comply with ADA Guidelines, specifying the structural strength of grab bars, tubs and shower seats. The grab rail shall be Invisia Collection model INV-SHS-\_\_\_\_ (see table below for appropriate product code).

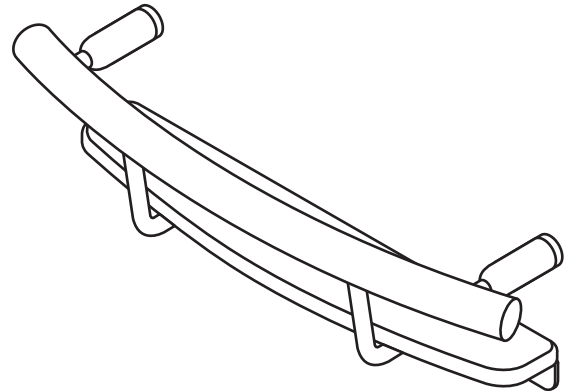

### Key Features

- Elegant Design with Integrated Support
- Removeable Shelf for Cleaning
- Solid Construction and Discreet Mounting
- Suitable For Use in a Wet Environment
- 500lbs / 227kg Weight Capacity

### Codes and Standards

- ADA 609.2 Cross Section
- ADA 609.8 Structural Strength



### Specified Model

MODEL	AA - FINISH	MATERIAL
INV-SHS-AA	CP (Polished Chrome) BS (Brushed Stainless) BLK (Matte Black) ORB (Oil Rubbed Bronze)	#304 Stainless Steel

# Invisia™ Shampoo Shelf

with Support Rail

INVISIA  
LIVE BEAUTIFULLY

## Technical Data Sheet

### Product Dimensions

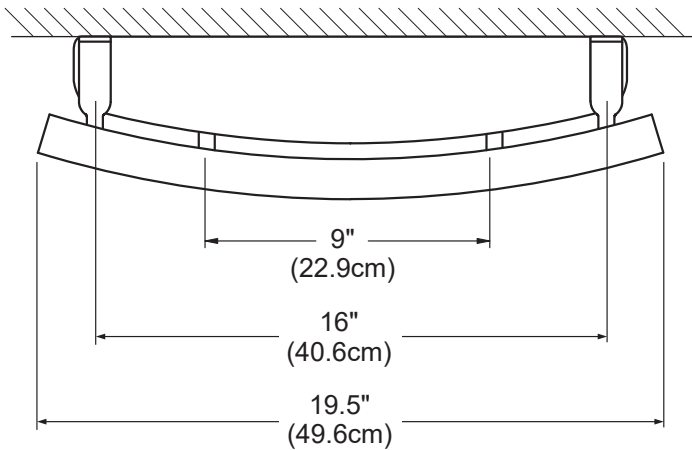

\*ADA Compliant

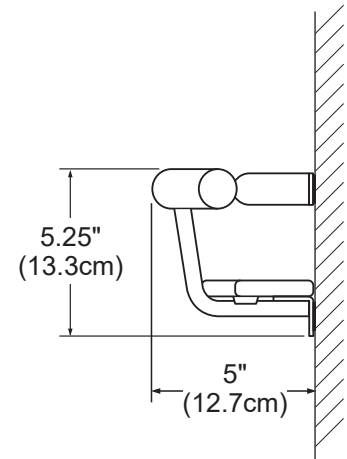
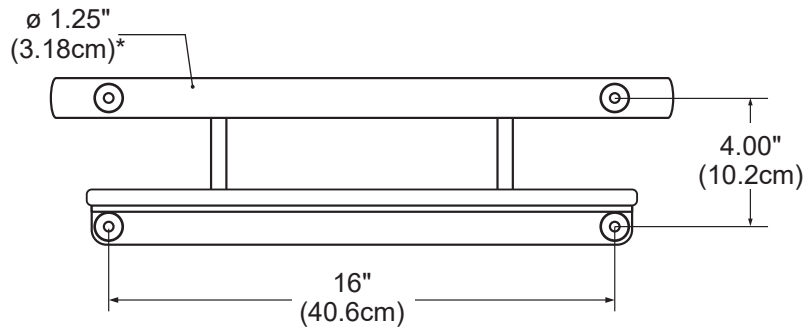

### Shipping Dimensions

Model	Height (H)	Width (W)	Depth (D)	Weight
SHS	5.5" / 14cm	21.7" / 55cm	7.9" / 20cm	7lbs / 3.2kg

