

INSTRUCTIONS

Modular Sofa

CARTON A PART LIST

A Left Armrest

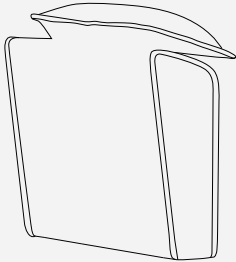

x1

B Right Armrest

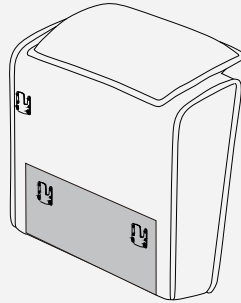

x1

1 Plastic Leg

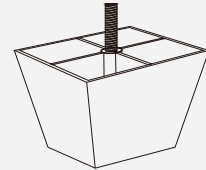

x4

2 Plastic Washer

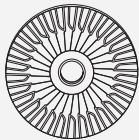

x4

3 Assembly Instructions

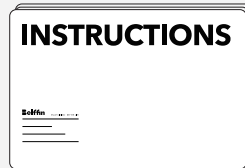

x1

CARTON B PART LIST

C Single Seat Frame

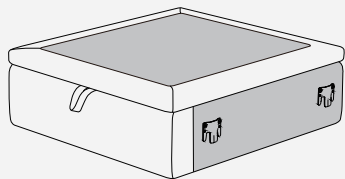

x1

D Single Back Frame

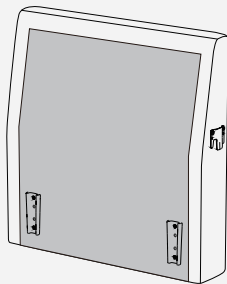

x1

E Seat Cushion

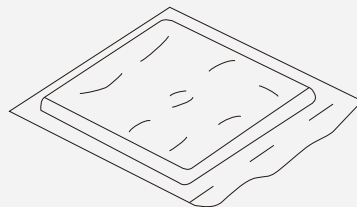

x1

F Removable Seat Cushion

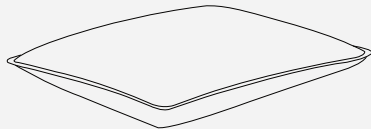

x1

G Back Pillow

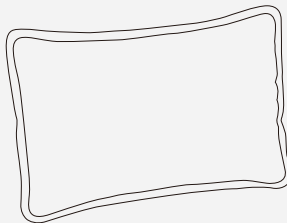

x1

1 Plastic Leg

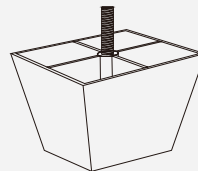

x4

CARTON B PART LIST

2 Plastic Washer

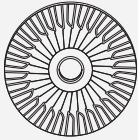

x4

CARTON C PART LIST

H Long Storage Seat Frame

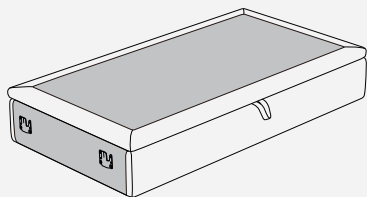

x1

E Seat Cushion

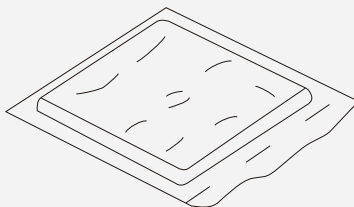

x1

F Removable Seat Cushion

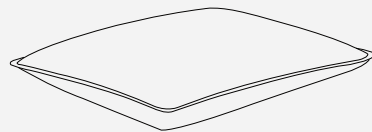

x2

1 Plastic Leg

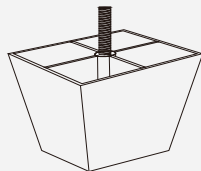

x4

2 Plastic Washer

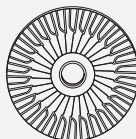

x4

CARTON D PART LIST

I Corner Seat Frame

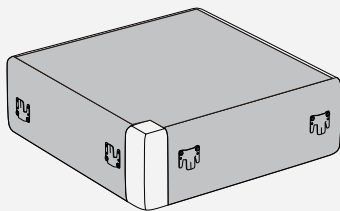

x1

K Corner Short Back Frame

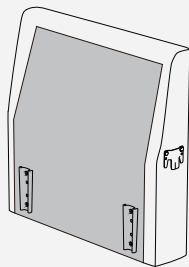

x1

L Corner Long Back Frame

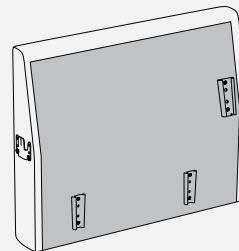

x1

M Corner Seat Cushion

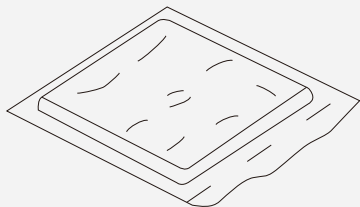

x1

F Removable Seat Cushion

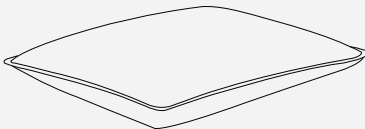

x1

G Back Pillow

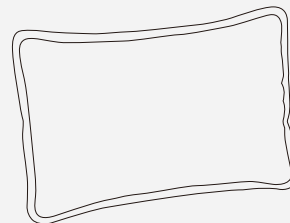

x2

CARTON D PART LIST

1 Plastic Leg

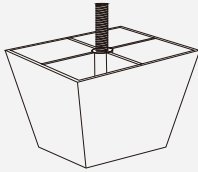

x4

2 Plastic Washer

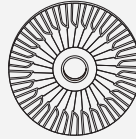

x4

CARTON E PART LIST

O Chaise Seat Frame

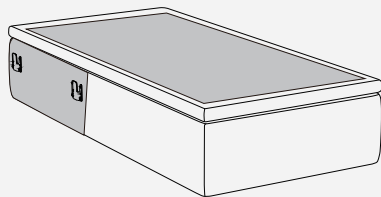

x1

D Single Back Frame

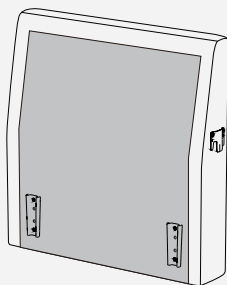

x1

P Chaise Removable Seat Cushion

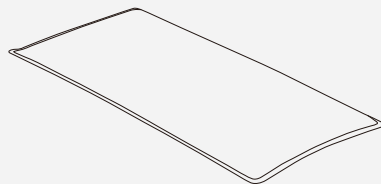

x1

Q Chaise Seat Cushion

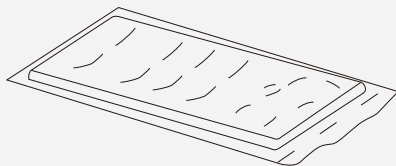

x1

G Back Pillow

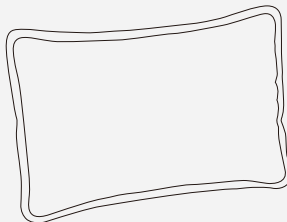

x1

1 Plastic Leg

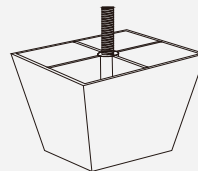

x4

CARTON E PART LIST

2 Plastic Washer

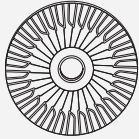

x4

CARTON H PART LIST

E Seat Cushion

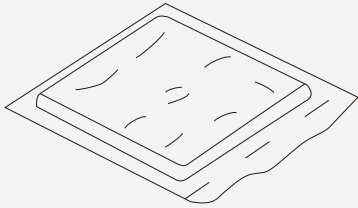

x1

D Single Back Frame

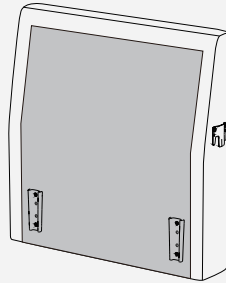

x2

G Back Pillow

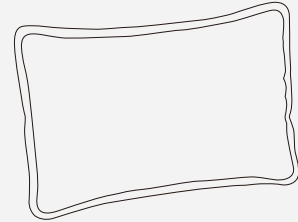

x2

ASSEMBLY

1. Please open all cartons and remove all parts from them carefully.
Place all parts on protected surface or carpet.
2. Please connect the right armrest (part B in the carton A) with the seat frame first, then connect the rest seat frames according to the assembly instructions.
3. Then please insert all the backrests into the seat frames, and connect the left armrest (part A in the carton A) finally with the seat frame according to the assembly instructions

Step1:

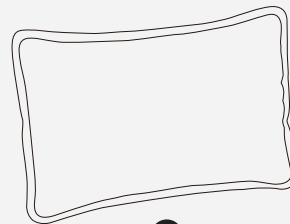
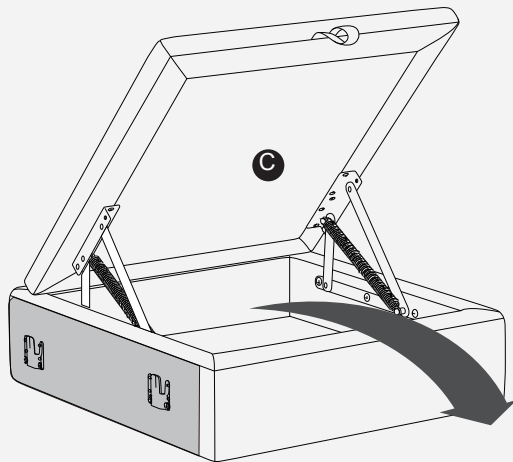

C

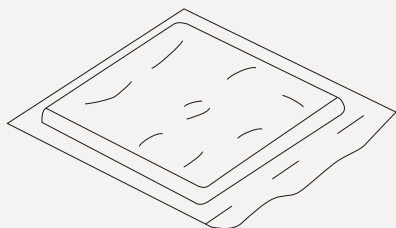

E

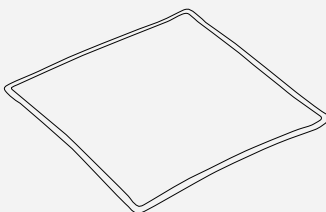

F

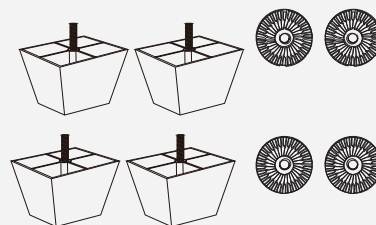

1

2

Step2:

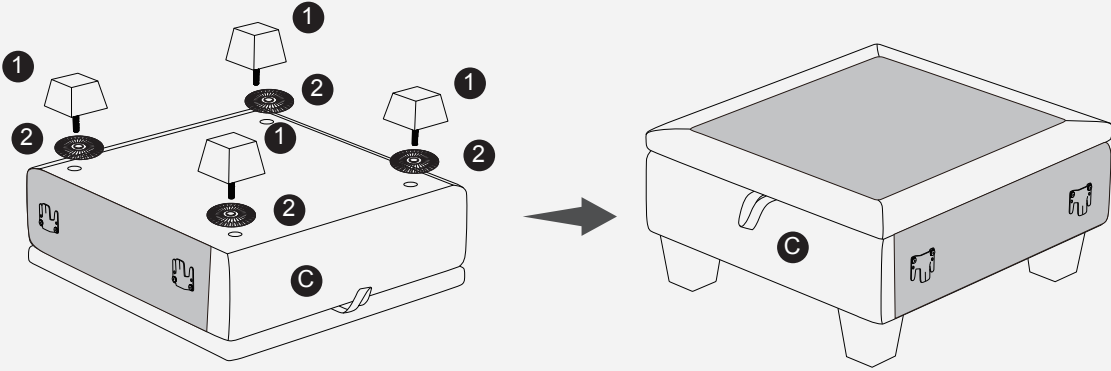

Step3:

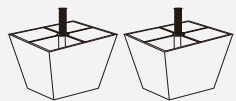
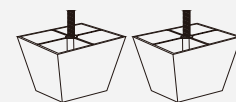
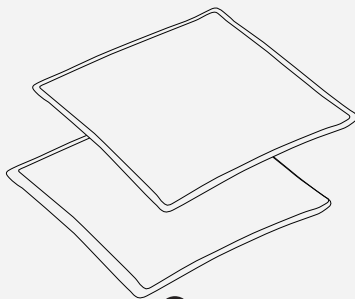
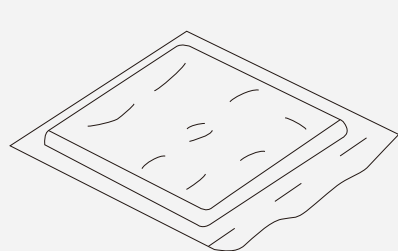
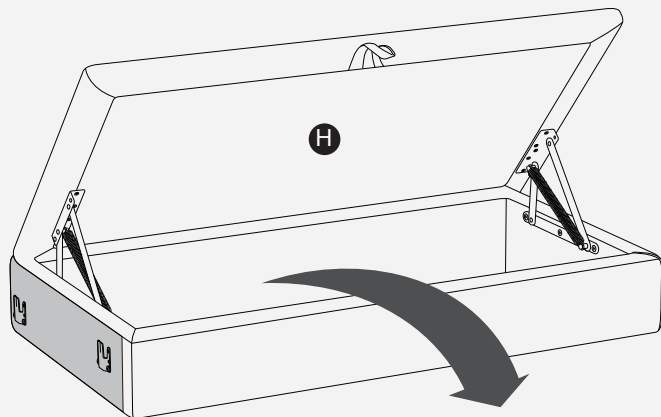

Step4:

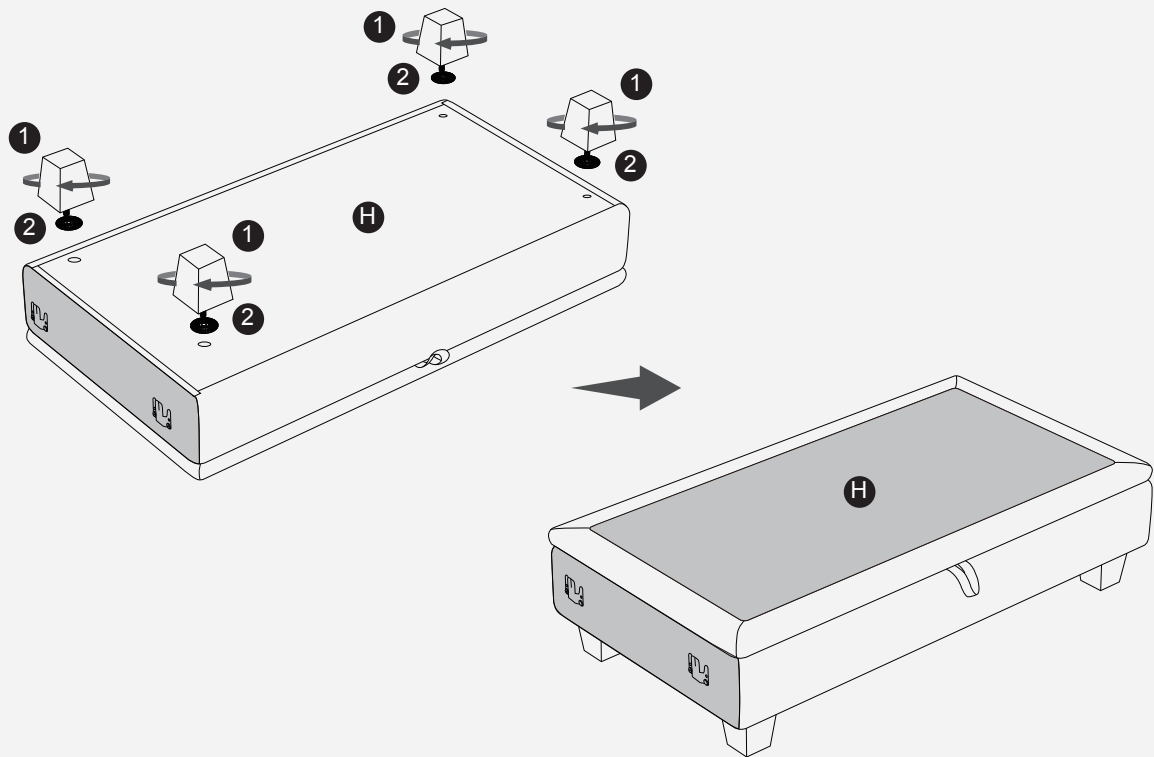

Step5:

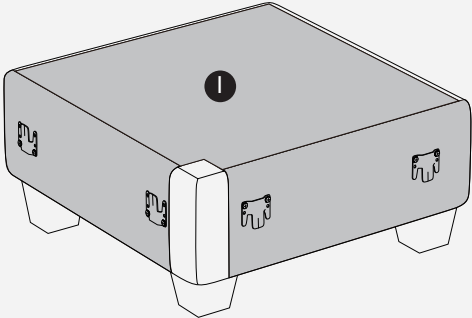
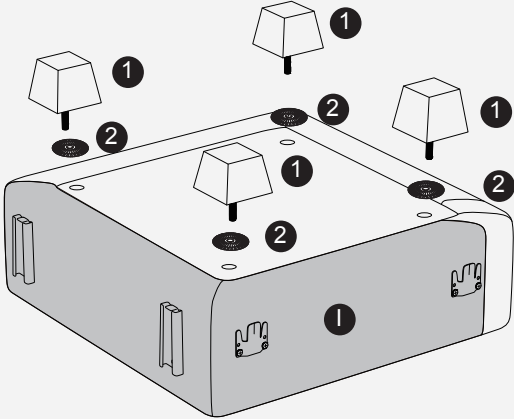

Step6:

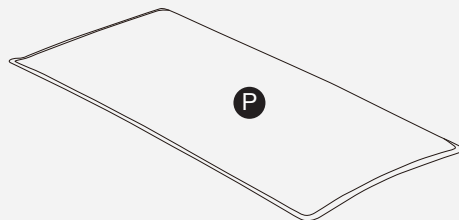
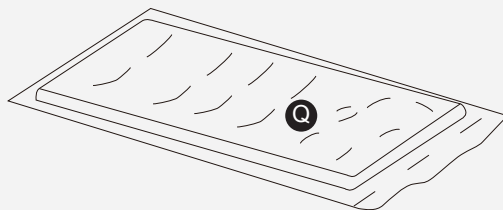
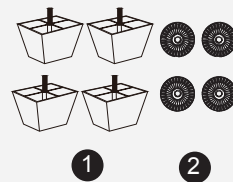
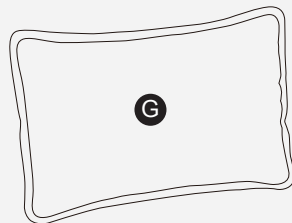
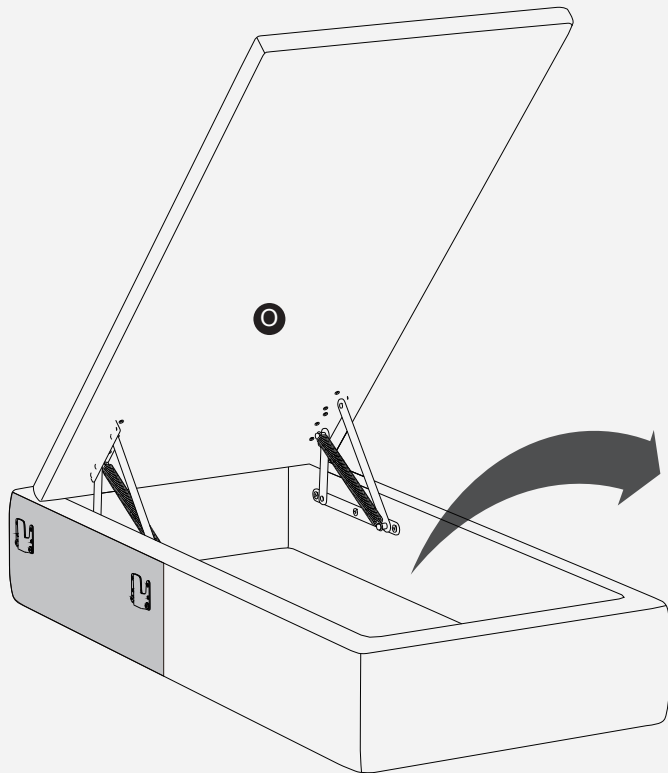

Step7:

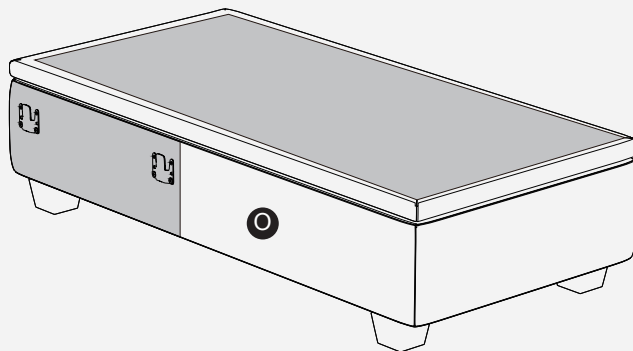
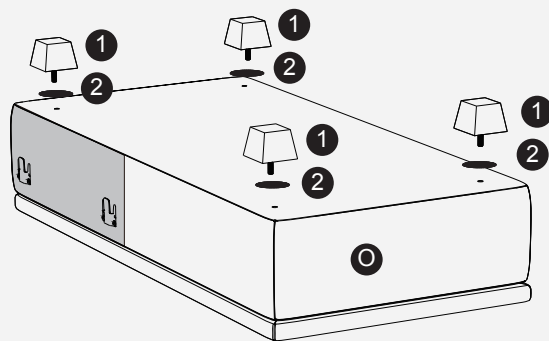

Step8:

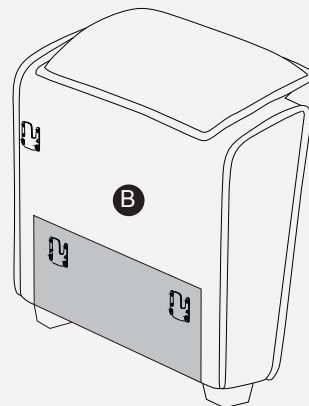
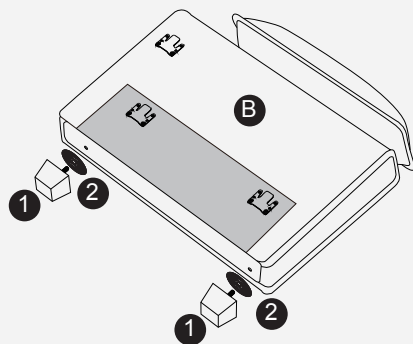
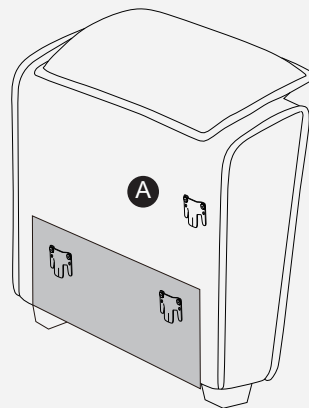
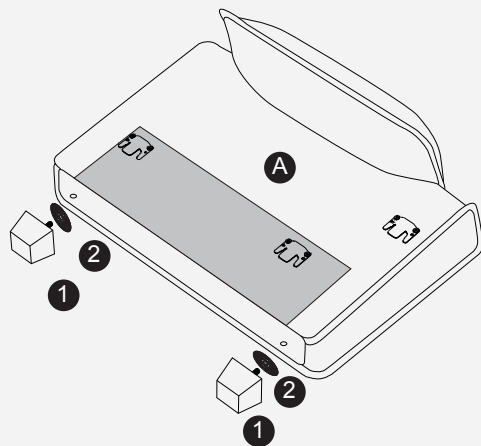

Step9:

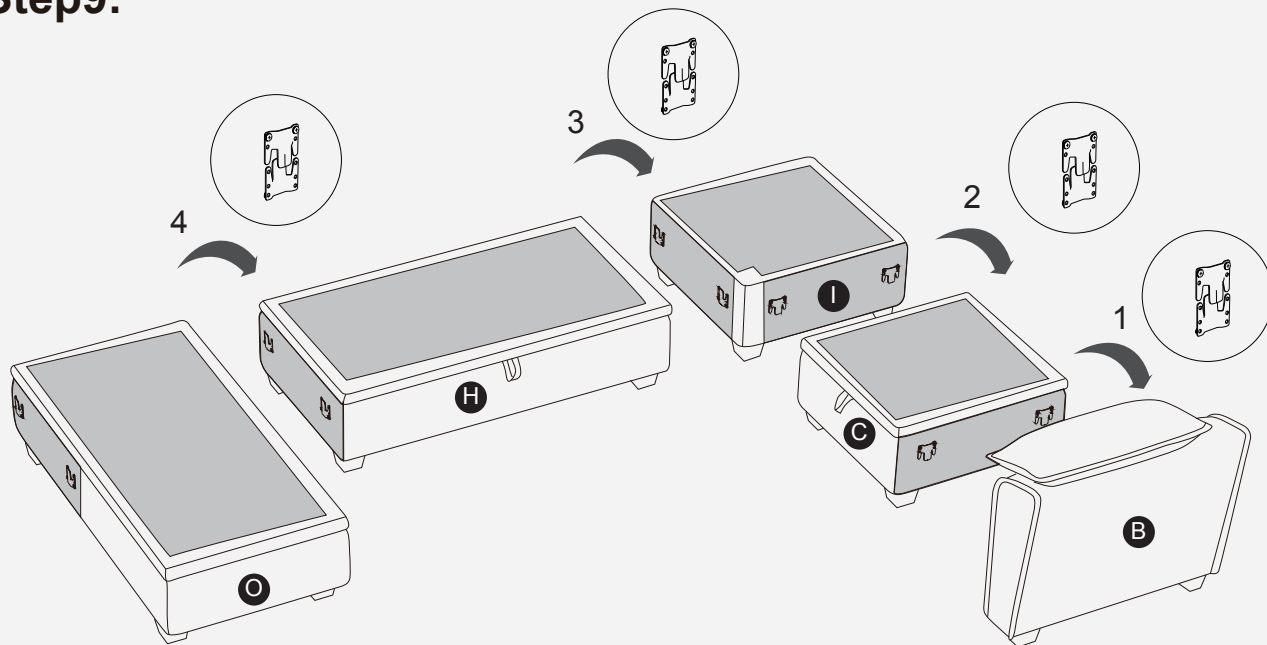

Step10:

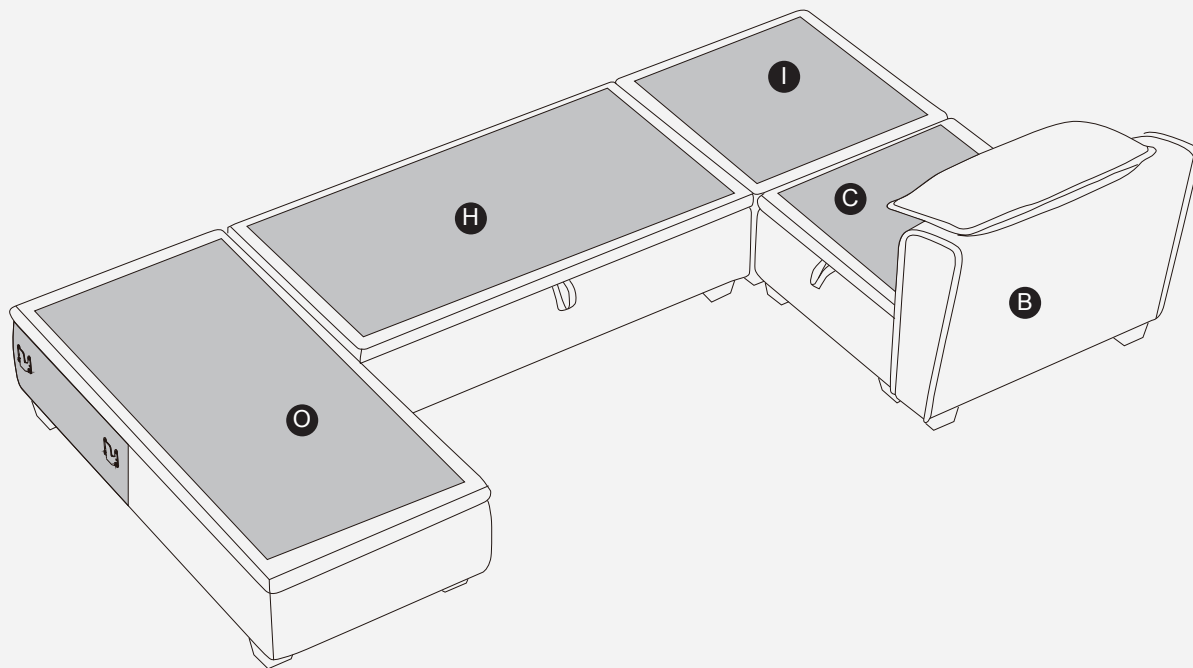

Step11:

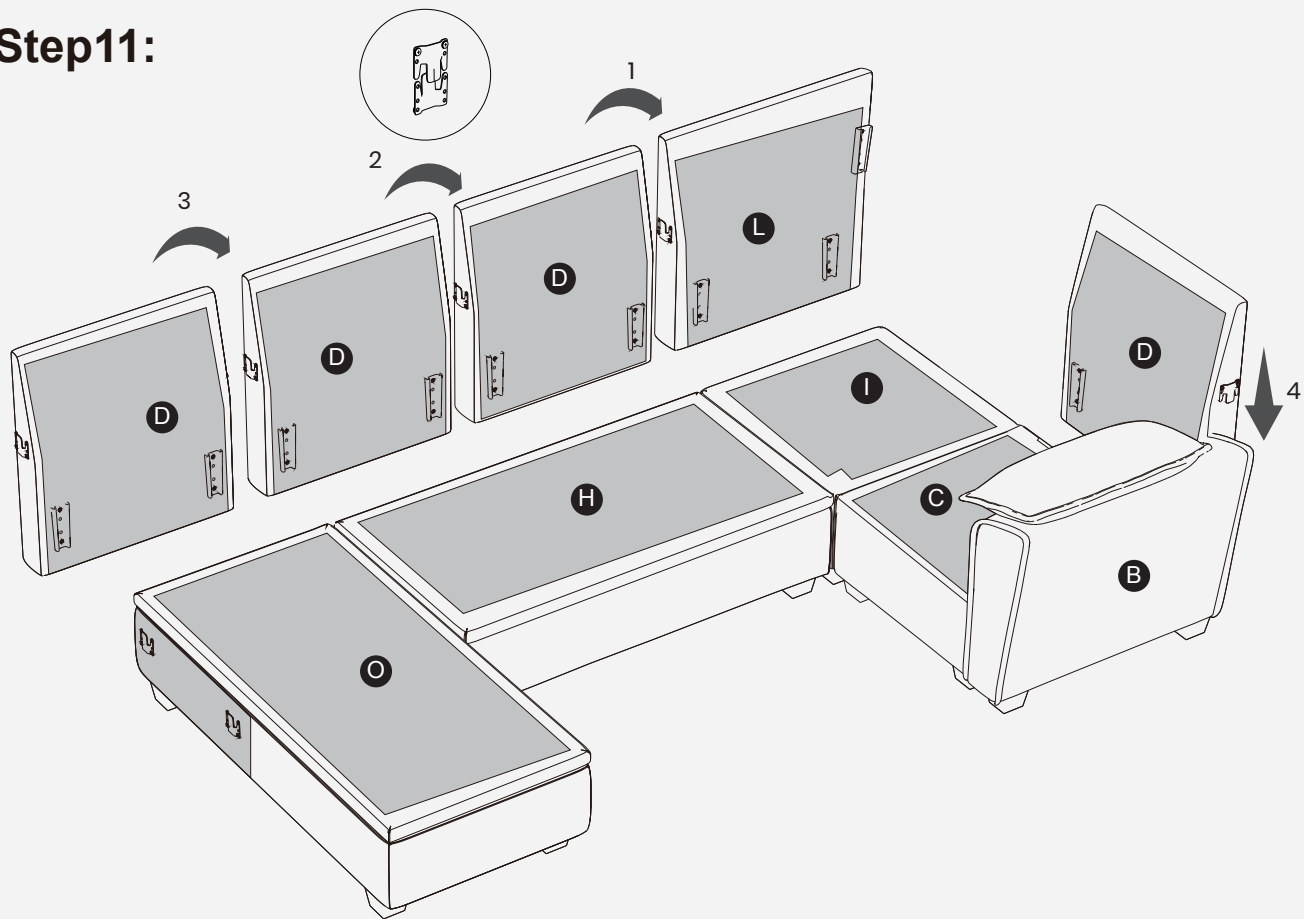

Step12:

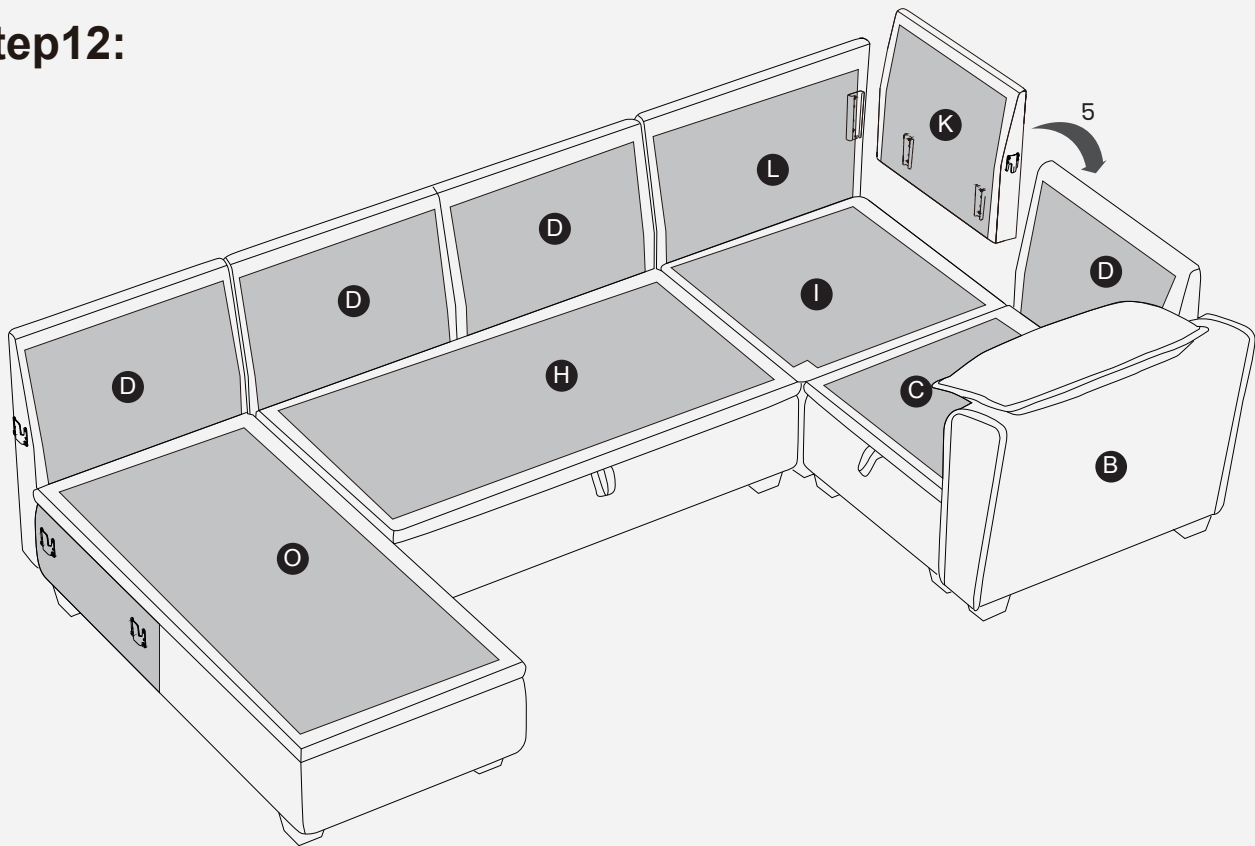

Step13:

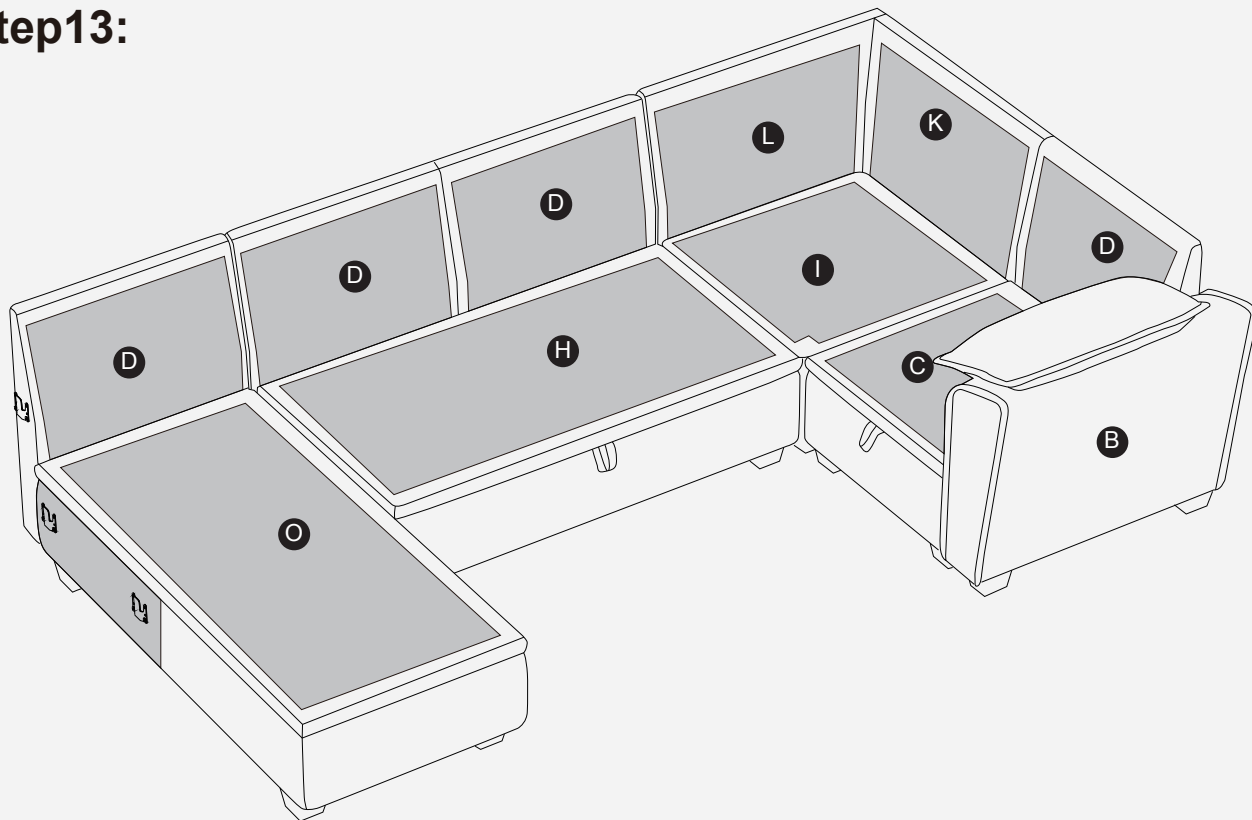

Step14:

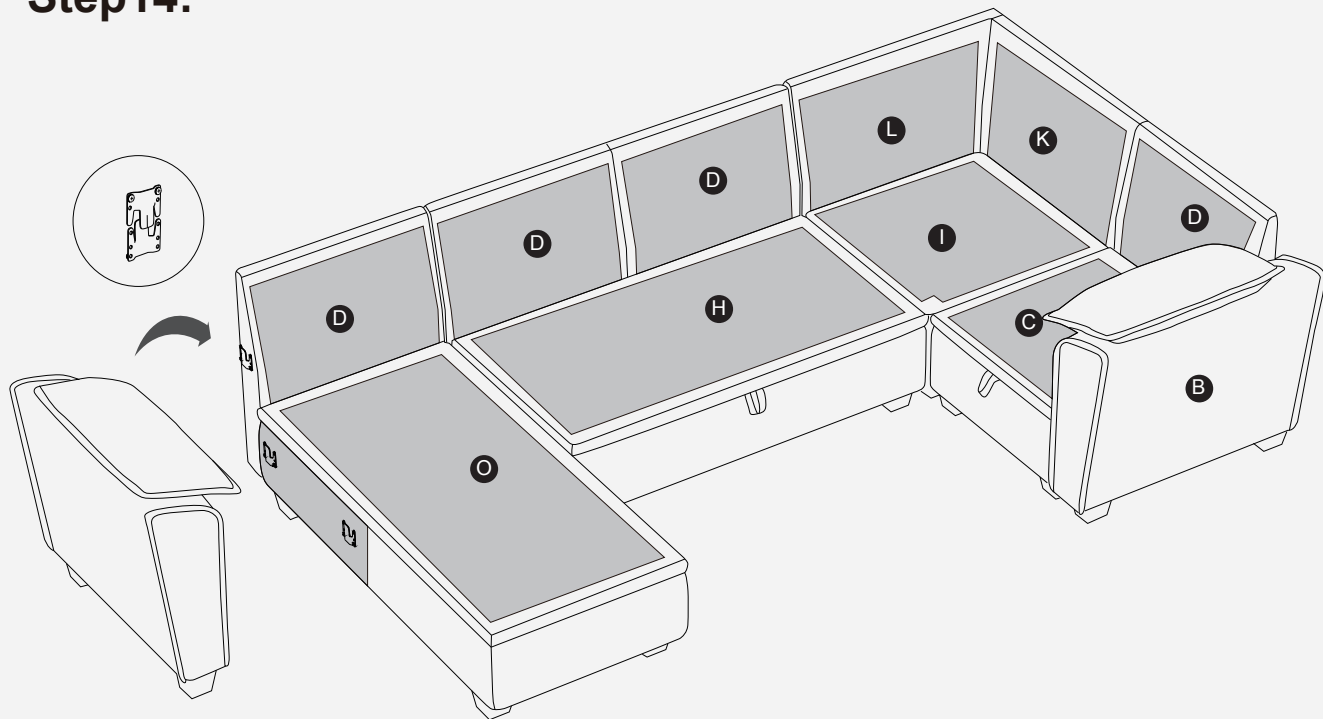

Step15:

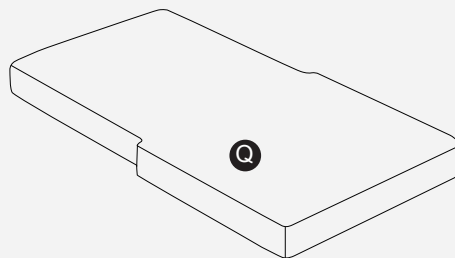
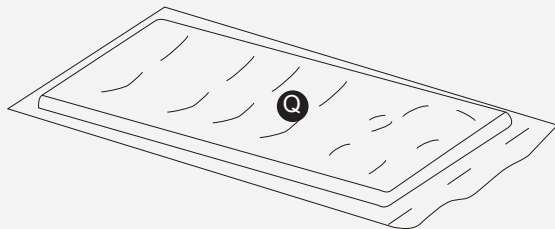
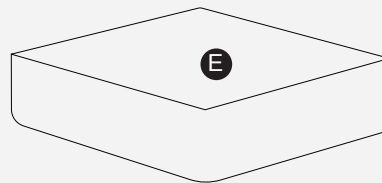
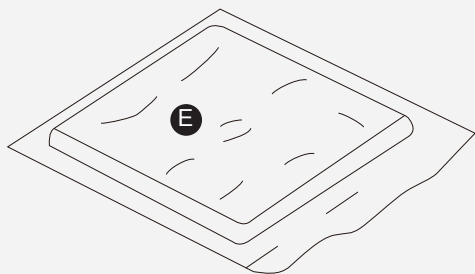
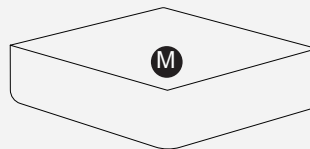
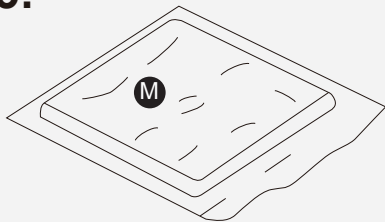

Step16:

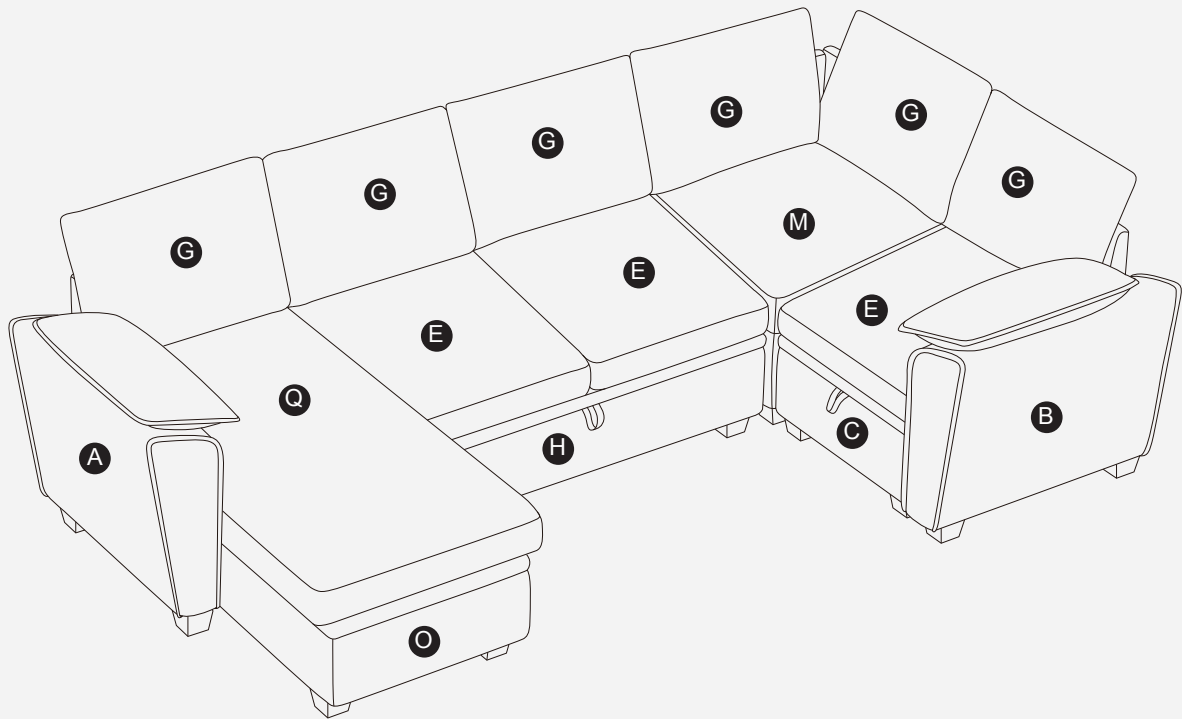

Step17:

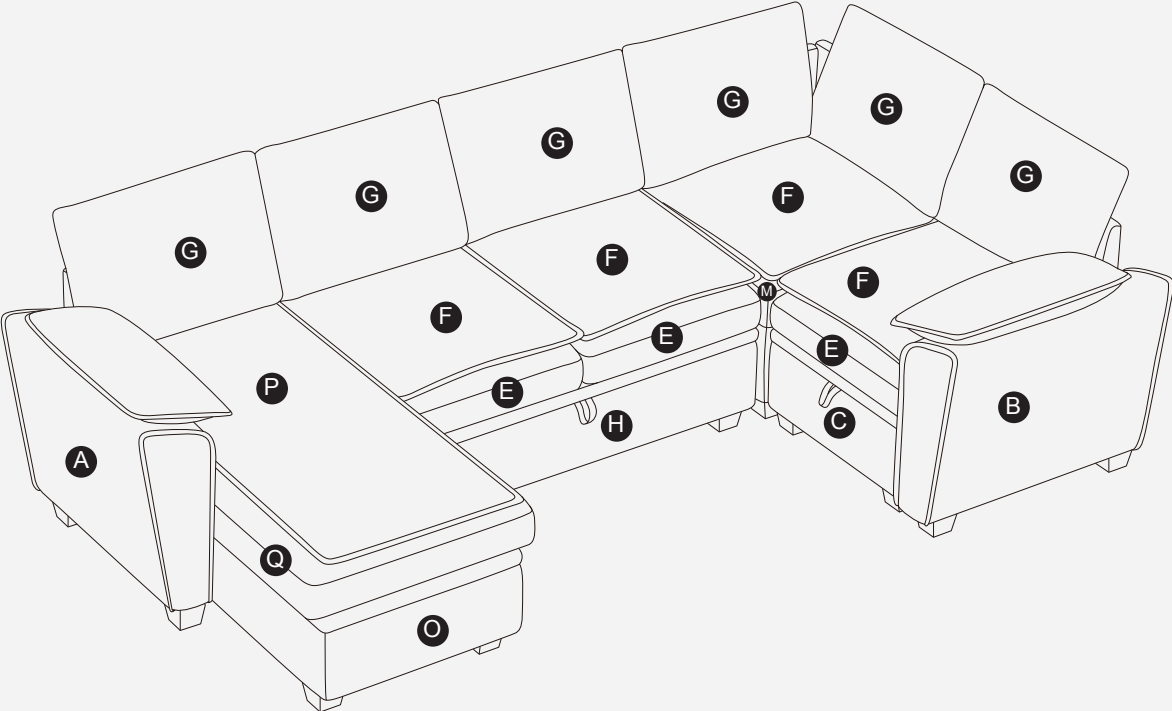

FREE COMBINATION

