

# Assembly Instructions

D1605-10 LISBON RECTANGLE DINING TABLE

Thank you for purchasing this quality product. Be sure to check all packing materials carefully for small parts, which may have come loose inside the carton during shipment. Identify and count all items and compare with the PARTS LIST and/or HARDWARE LIST shown below.



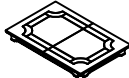
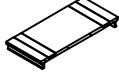
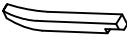

**Caution:** Please read the instructions thoroughly before assembly.

1. We recommend that you assemble this product with the assistance of another person: this will make the assembly easier, and will help eliminate damage to the product or injury to persons during assembly.
2. Please do not over tighten screws or bolts until the assembly is completed.
3. Please put all parts on a non-abrasive floor before assembly, and follow the assembly steps to assemble your newly purchased product correctly and efficiently

## PARTS LIST

NO:	COMPONENT	DRAWING	Q'TY
A	TABLE TOP		1PC
B	TABLE LEAF		1PC
C	TABLE LEG		4PCS

## HARDWARE LIST

NO:	COMPONENT	DRAWING	Q'TY
1	Bolt Ø5/16"x2-3/8"		8pcs
2	Lock Washer Ø5/16"		8pcs
3	Flat Washer Ø5/16"x3/4"		8pcs
4	Wrench Ø5/16"		1pc

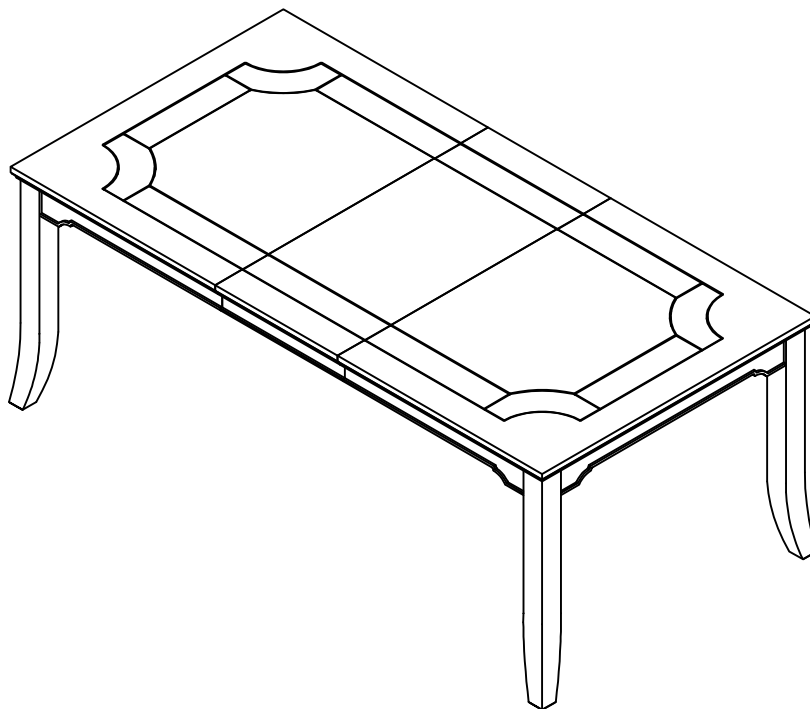
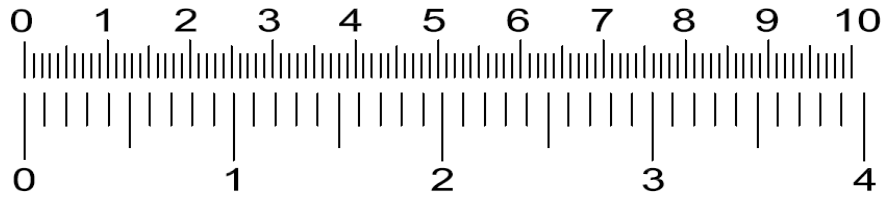

# Assembly Instructions

D1605-10 LISBON RECTANGLE DINING TABLE

## STEP 1

Place the Table Top (A) upside down on a soft and flat surface. Assemble Table Legs (C) by using Wrench (4) with hardware 1, 2, and 3.

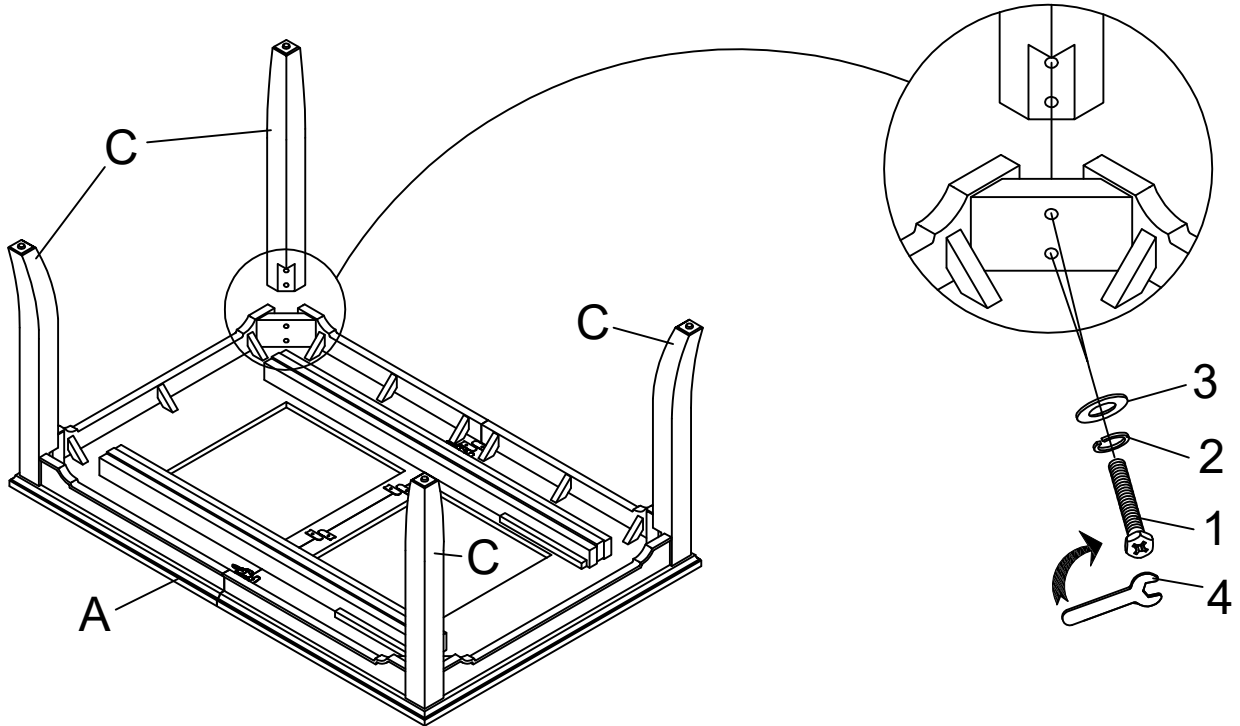

## STEP 2

To level the table, stand the table up right on a flat surface and adjust the levelers on the bottom of the table legs.

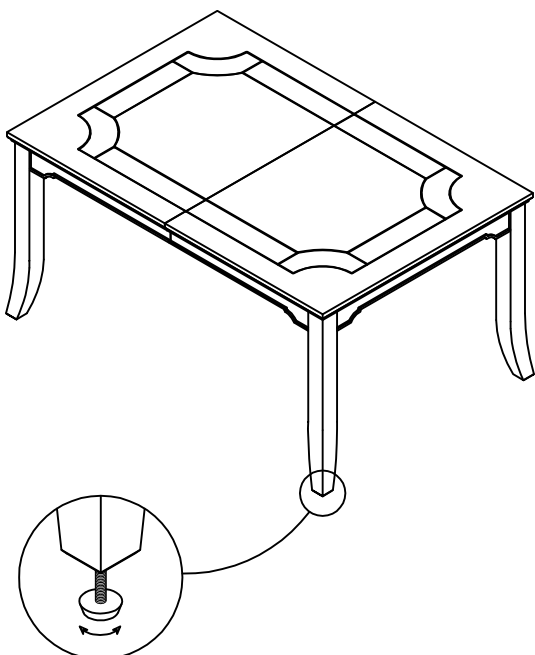

## STEP 3

To install the Table Leaf, unlatch the locks under the Table Top (A). Pull outward at both ends of the table to open the space for the Table Leaf. Place the Table Leaf (B) in the middle opening to align and insert the dowels on the leaf into the holes at one end of the table. Push inward at both ends of the table to close and latch the locks under the Table Top (A).

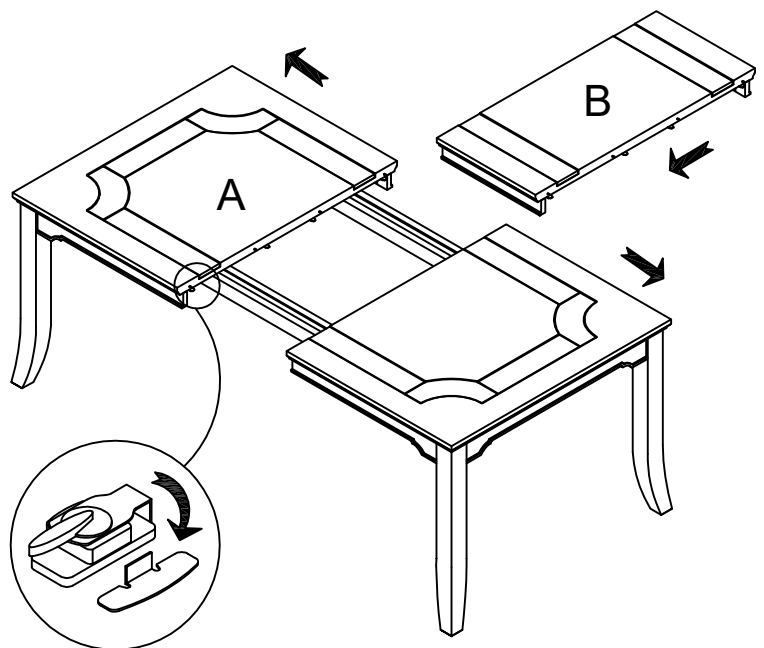

# Assembly Instructions



D1605-20 LISBON DINING SIDE CHAIR

Thank you for purchasing this quality product. Be sure to check all packing materials carefully for small parts, which may have come loose inside the carton during shipment. Identify and count all items and compare with the PARTS LIST and/or HARDWARE LIST shown below.







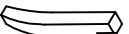
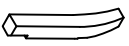
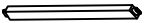
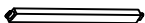

**Caution:** Please read the instructions thoroughly before assembly.

1. We recommend that you assemble this product with the assistance of another person: this will make the assembly easier, and will help eliminate damage to the product or injury to persons during assembly.
2. Please do not over tighten screws or bolts until the assembly is completed.
3. Please put all parts on a non-abrasive floor before assembly, and follow the assembly steps to assemble your newly purchased product correctly and efficiently

## PARTS LIST

NO:	COMPONENT	DRAWING	Q'TY
A	Chair Back		2PCS
B	Seat		2PCS
C	Left Side Facing (LSF) Leg		2PCS
D	Right Side Facing (RSF) Leg		2PCS
E	Left Side Facing (LSF) Stretcher		2PCS
F	Right Side Facing (RSF) Stretcher		2PCS

## HARDWARE LIST

NO:	COMPONENT	DRAWING	Q'TY
1	Bolt Ø5/16"x2-3/4"		16pcs
2	Lock Washer Ø5/16"		16pcs
3	Flat Washer Ø5/16"x3/4"		16pcs
4	Wrench Ø5/16"		2pcs
5	Bolt Ø1/4"x1-3/4"		2pcs
6	Lock Washer Ø1/4"		2pcs
7	Flat Washer Ø1/4"x5/8"		2pcs
8	Allen key		2pcs
9	Screw: #8*1-3/4"		8pcs

**WEIGHT CAPACITY (PER CHAIR): 275 LBS**

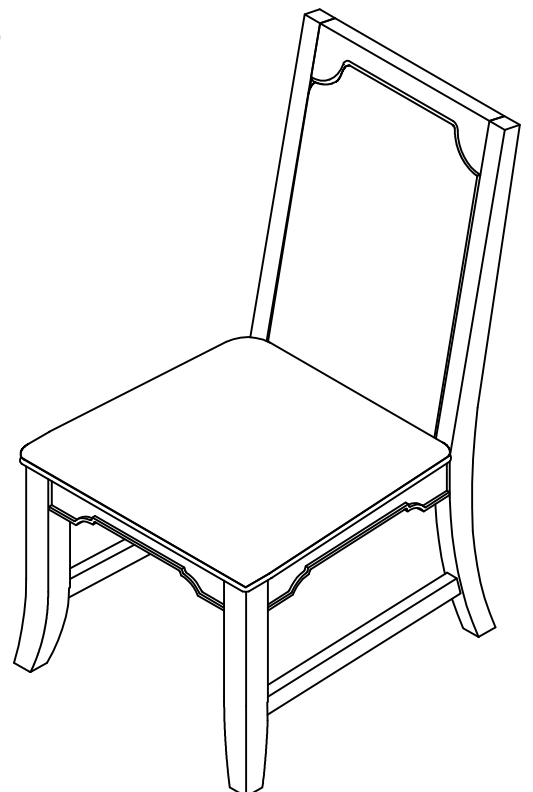
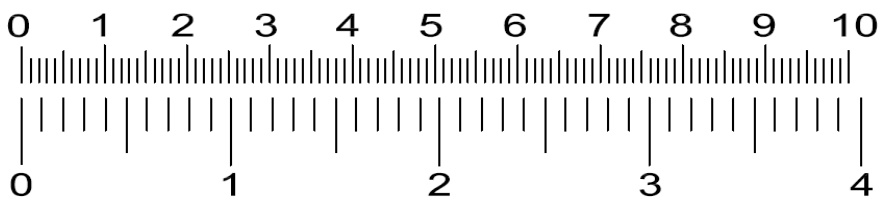

## STEP 1

Place the Chair Back (A) on a soft and clean surface.  
Assemble the Seat (B) with the Chair Back (A) by using Allen Key (8) with hardware 5, 6, and 7.

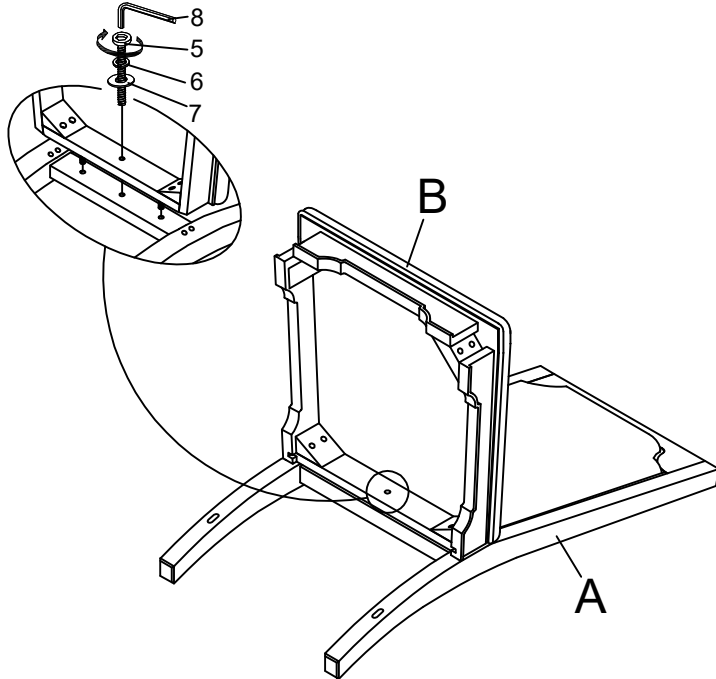

## STEP 2

Assemble the Seat (B) with the back legs of the Chair Back (A) by using Wrench (4) with hardware 1, 2, and 3.  
**\*\*Attention: DO NOT TIGHTEN THE BOLTS**

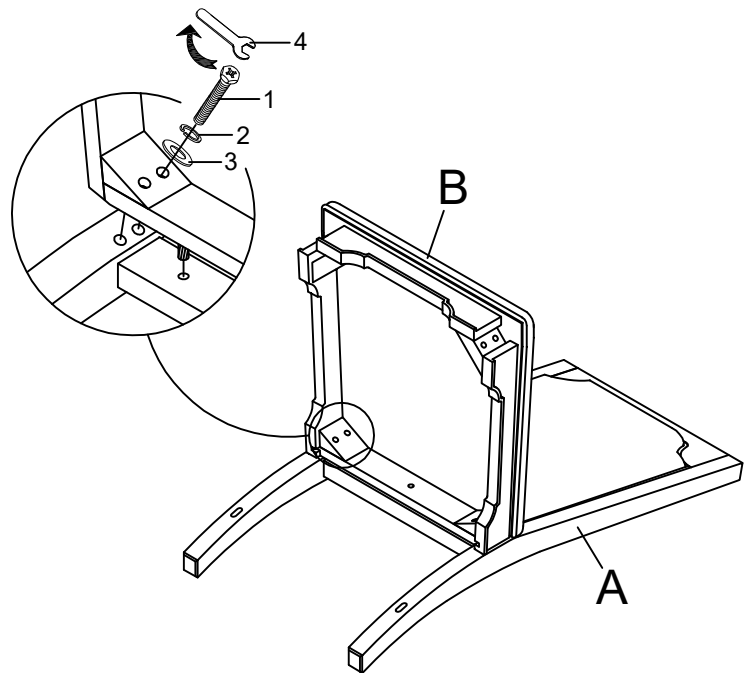

## STEP 3

Place LSF Stretcher (E) and between backrest (A) and LSF Leg (C), then place RSF Stretcher (F) between backrest (A) and RSF Leg (D).

Assemble the Legs (C & D) with the Seat (B) by using Wrench (4) with hardware 1, 2, and 3.

**\*\*Attention: DO NOT TIGHTEN THE BOLTS.**

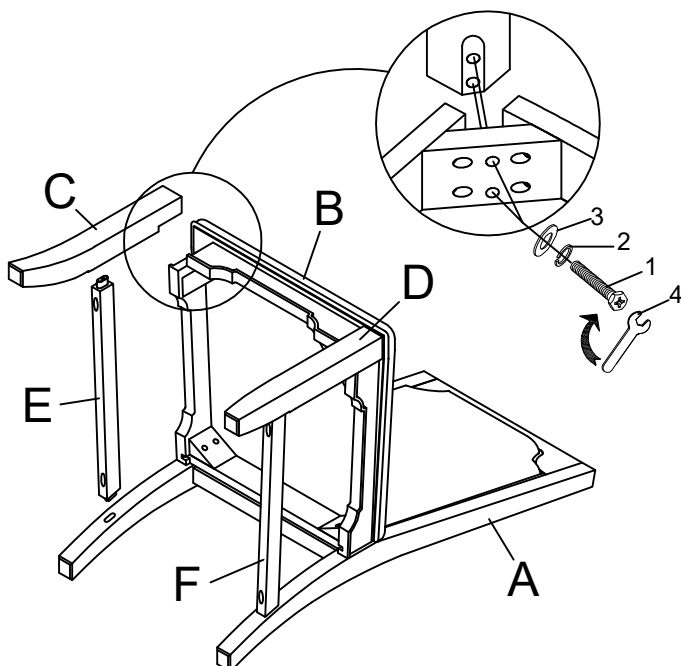

## STEP 4

Assemble the LSF Stretcher (E) with LSF Leg (C) and the back leg of the Chair Back (A) by using a screwdriver with hardware 9.

Repeat the step to assemble the RSF Stretcher (F).

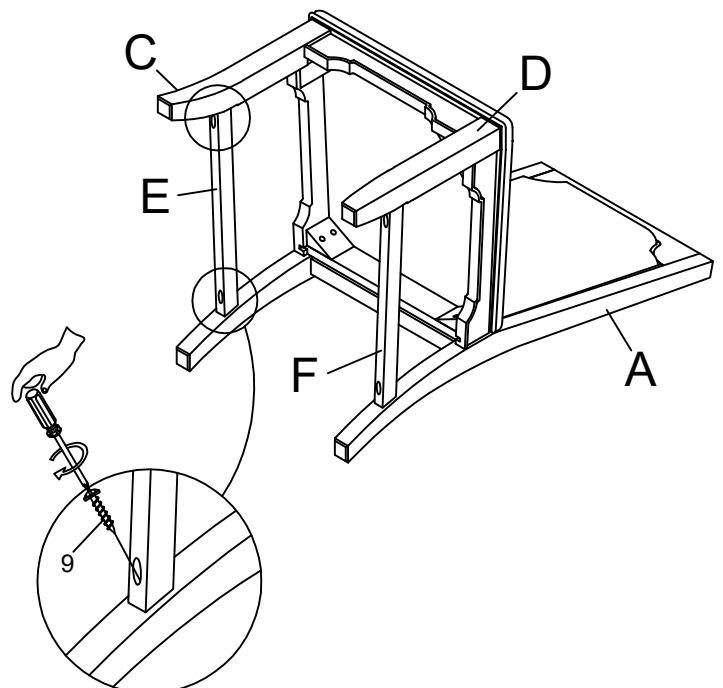

## STEP 5

To level the chair, stand the chair up on a flat surface and tighten all the bolts by using Wrench (4).

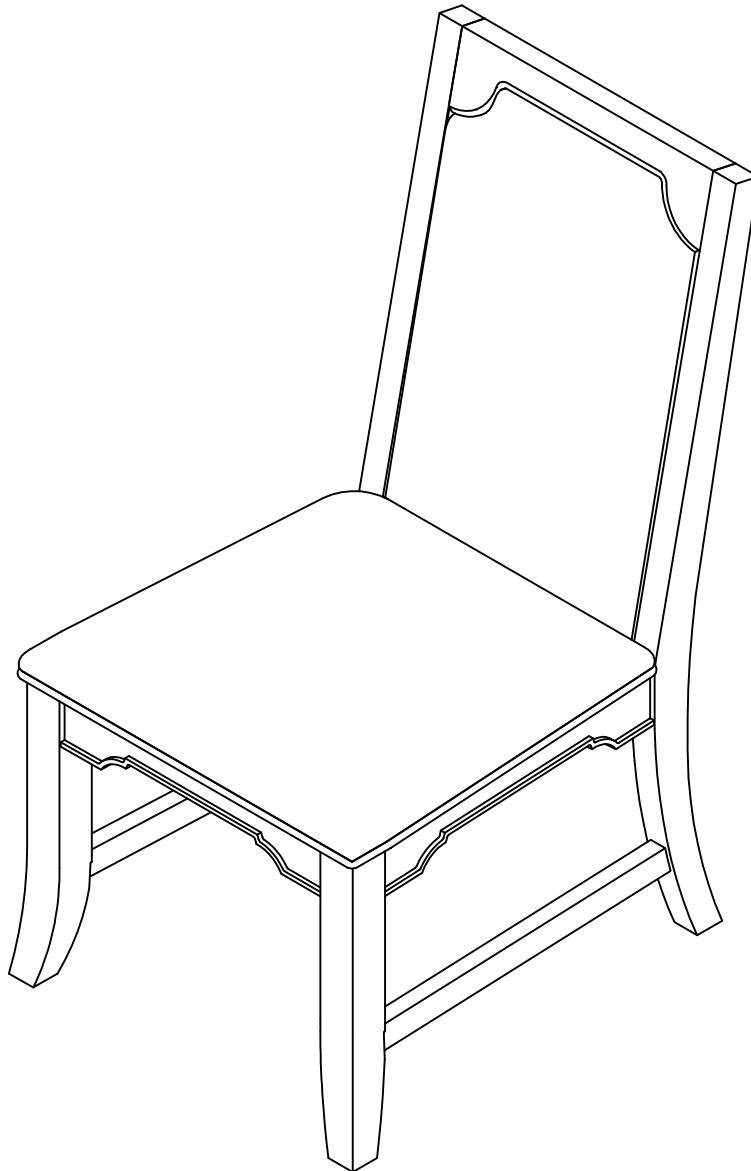

# Assembly Instructions







D1605-25 LISBON DINING ARM CHAIR

Thank you for purchasing this quality product. Be sure to check all packing materials carefully for small parts, which may have come loose inside the carton during shipment. Identify and count all items and compare with the PARTS LIST and/or HARDWARE LIST shown below.





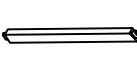
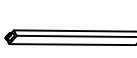



**Caution:** Please read the instructions thoroughly before assembly.

1. We recommend that you assemble this product with the assistance of another person: this will make the assembly easier, and will help eliminate damage to the product or injury to persons during assembly.
2. Please do not over tighten screws or bolts until the assembly is completed.
3. Please put all parts on a non-abrasive floor before assembly, and follow the assembly steps to assemble your newly purchased product correctly and efficiently

## PARTS LIST

NO:	COMPONENT	DRAWING	Q'TY
A	Chair Back		2PCS
B	Seat		2PCS
C	Left Side Facing (LSF) Leg		2PCS
D	Right Side Facing (RSF) Leg		2PCS
E	Left Side Facing (LSF) Stretcher		2PCS
F	Right Side Facing (RSF) Stretcher		2PCS
G	Left Side Facing (LSF) Arm		2PCS
H	Right Side Facing (RSF) Arm		2PCS

## HARDWARE LIST

NO:	COMPONENT	DRAWING	Q'TY
1	Bolt Ø5/16"x2-3/4"		16pcs
2	Lock Washer Ø5/16"		16pcs
3	Flat Washer Ø5/16"x3/4"		16pcs
4	Wrench Ø5/16"		2pcs
5	Bolt Ø1/4"x1-3/4"		10pcs
6	Lock Washer Ø1/4"		10pcs
7	Flat Washer Ø1/4"x5/8"		10pcs
8	Allen key		2pcs
9	Screw: #8*1-3/4"		12pcs

**WEIGHT CAPACITY (PER CHAIR): 275 LBS**

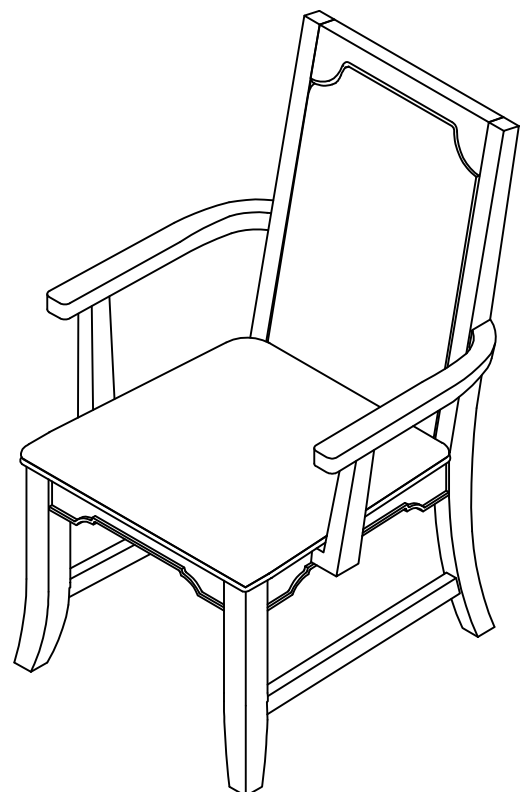
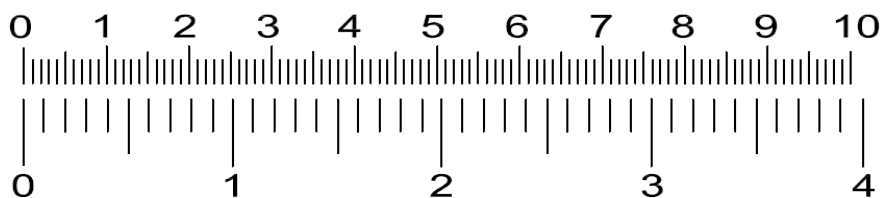

# Assembly Instructions

D1605-25 LISBON DINING ARM CHAIR

## STEP 1

Place the Chair Back (A) on a soft and clean surface.  
Assemble the Seat (B) with the Chair Back (A) by using Allen Key (8) with hardware 5, 6, and 7.

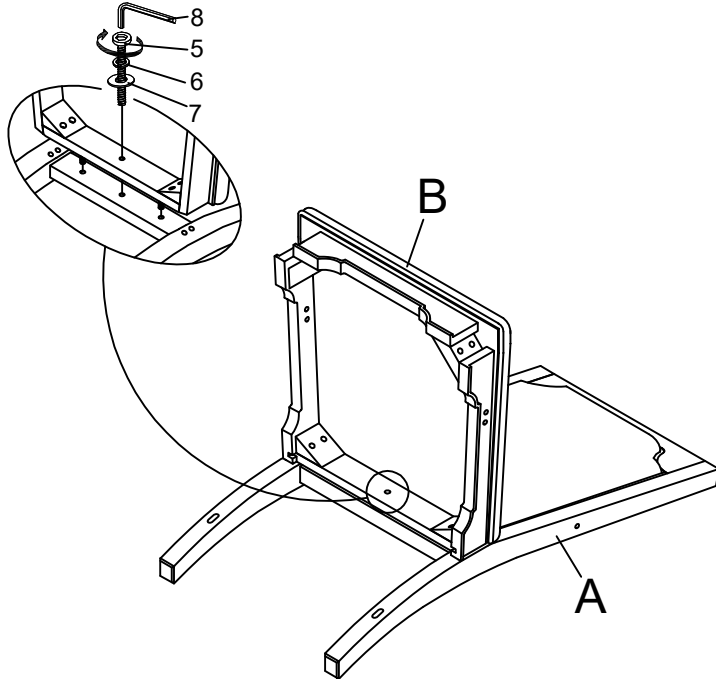

## STEP 2

Assemble the Seat (B) with the back legs of the Chair Back (A) by using Wrench (4) with hardware 1, 2, and 3.  
**\*\*Attention: DO NOT TIGHTEN THE BOLTS**

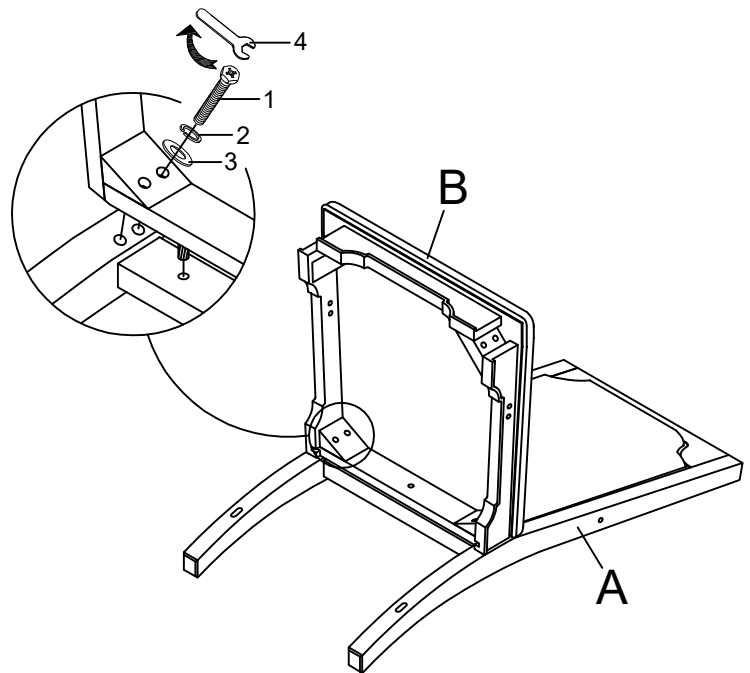

## STEP 3

Place LSF Stretcher (E) and between backrest (A) and LSF Leg (C), then place RSF Stretcher (F) between backrest (A) and RSF Leg (D).

Assemble the Legs (C & D) with the Seat (B) by using Wrench (4) with hardware 1, 2, and 3.

**\*\*Attention: DO NOT TIGHTEN THE BOLTS.**

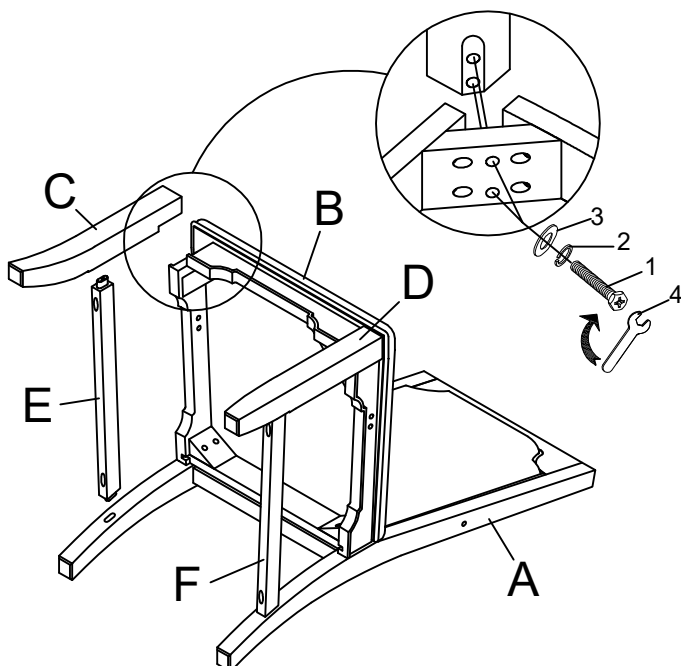

## STEP 4

Assemble the LSF Stretcher (E) with LSF Leg (C) and the back leg of the Chair Back (A) by using a screwdriver with hardware 9.

Repeat the step to assemble the RSF Stretcher (F).

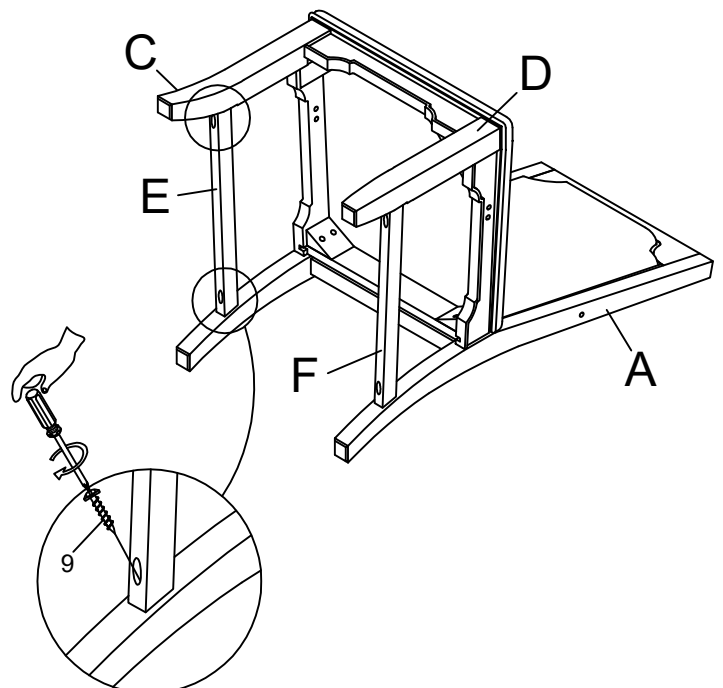

## STEP 5

Assemble the LSF Arm (G) with the Seat (B) by using Allen Key (8) with hardware 5, 6, and 7. Then assemble the LSF Arm (G) with the Chair Back (A) by using a screwdriver with hardware 9. Repeat the step to assemble the RSF Arm (H).

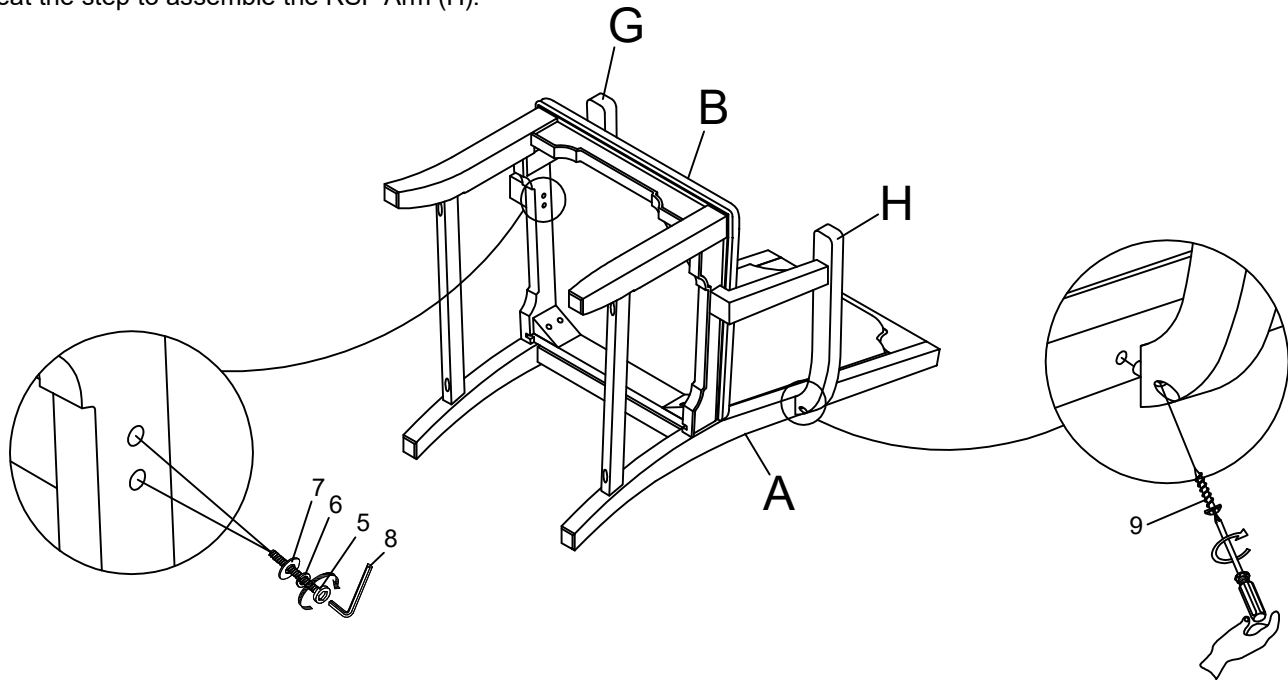

## STEP 6

To level the chair, stand the chair up on a flat surface and tighten all the bolts by using Wrench (4).

